



German soldiers from the Rapid Response Forces Division move toward simulated enemy forces during NATO exercise Green Griffin 21 on 4 October 2021 at Lehnin, Germany. Green Griffin is an annual NATO training exercise designed to increase the scale, capability, and interoperability of NATO allies and partner forces. The exercise involved elements from the U.S. Army's 12th Combat Aviation Brigade, the Bundeswehr's Rapid Response Forces Division, the Netherlands air force, and the Romanian army's Mechanized Brigade. (Photo by Michele Wiencek, U.S. Army)

# Multi-Domain Warfighting in NATO

## The 1 German-Netherlands Corps View

Lt. Gen. Andreas Marlow, German Army

Lt. Col. Wilson C. Blythe Jr., U.S. Army

Since its formation in 1995 as a result of the merger of the Cold War-era 1 German Corps and 1 Dutch Corps, 1 German-Netherlands (GE/NL) Corps has repeatedly confirmed the commitment of its framework nations (Germany and Netherlands) to NATO, deploying to Afghanistan in 2003, 2009, and 2013. To continue this commitment, deter aggression, and defend the Euro-Atlantic area, 1 (GE/NL) Corps must demonstrate the ability to conduct large-scale combat operations as part of NATO against a peer enemy in an Article 5 scenario. The ability to conduct large-scale combat operations underpins the credibility of the Alliance's deterrence and provides the basis for the defense of the Euro-Atlantic area in the event of conflict. This means that 1 (GE/NL) Corps must possess the ability to successfully perform the warfighting corps role, following its 2023 stand-by period as the NATO Response Force (NRF) Land Component Command (LCC).<sup>1</sup>

Execution of the warfighting corps role on the Euro-Atlantic multi-domain battlefields of today and tomorrow requires specific capabilities, in the required capacities, along with the expertise necessary to employ them in an Article 5 scenario against a peer enemy. As part of its transformation into a warfighting corps capable of multi-domain operations (MDO), 1 (GE/NL) Corps has conducted a campaign of learning consisting of academics, wargaming, and training and exercises. The results of this work are detailed below and specify the roles and responsibilities of a NATO warfighting corps within MDO, define the requirements and the structure for an MDO-capable warfighting corps, and describe the conduct of corps operations within the context of an Article 5 scenario.<sup>2</sup>

## Organization

In contrast to stabilization operations in which the corps acted as a command-and-control node, for warfighting operations the corps functions not only as a headquarters but also as a formation that consists of its headquarters, combat and maneuver support forces, sustainment units, and other functional support units assigned to, attached to, or under the operational control of the corps.<sup>3</sup> Also included are functional support capabilities operating in direct support of the corps or its subordinate divisions. Functional support units operating in the corps area of operations as general

support, but not part of the corps, are normally not included in the corps formation.

When operating in the context of an Article 5 or warfighting operation, the corps is the highest tactical echelon. It is task organized for the operation, taking into account the operational and mission variables, and that task organization is dependent on the relative combat power of the enemy formations with which the corps will be engaged, the mission it receives, and the size of the area of operations in which it will operate. There are several proposed corps structures for the MDO battlefields of today and tomorrow. While there is much overlap to these proposals, the 1 (GE/NL) Corps structure was specifically developed to focus on the threats to the Euro-Atlantic area (see figure 1, page 18).<sup>4</sup>

Ideally, a NATO corps capable of conducting multi-domain operations within the Euro-Atlantic area includes the following:

- ◆ 2 to 5 divisions
- ◆ 1 x military intelligence brigade
- ◆ 1 x intelligence, surveillance, and reconnaissance (ISR) battalion equipped with unmanned aircraft systems (UAS) and unattended ground sensors (UGS)
- ◆ 1 x electronic warfare battalion
- ◆ 1 x corps fires command
- ◆ 2 x long-range artillery brigades
- ◆ 1 x cyber company
- ◆ 1 x ISR/targeting battery equipped with UASs and UGSs
- ◆ 1 x aviation brigade
- ◆ 1 x armored reconnaissance and surveillance brigade
- ◆ 1 x information warfare battalion
- ◆ 1 x psyops company
- ◆ 1 x engineer brigade (including chemical, biological, radiological, and nuclear [CBRN] capacity)
- ◆ 1 x air defense brigade
- ◆ 1 x signal brigade with a dedicated cyber defense organization
- ◆ 1 x rear area operations command
- ◆ 1 x sustainment brigade
- ◆ 1 x medical brigade
- ◆ 1 x military police brigade
- ◆ 1 x CBRN defense battalion
- ◆ 1 x civil affairs battalion with a political liaison team

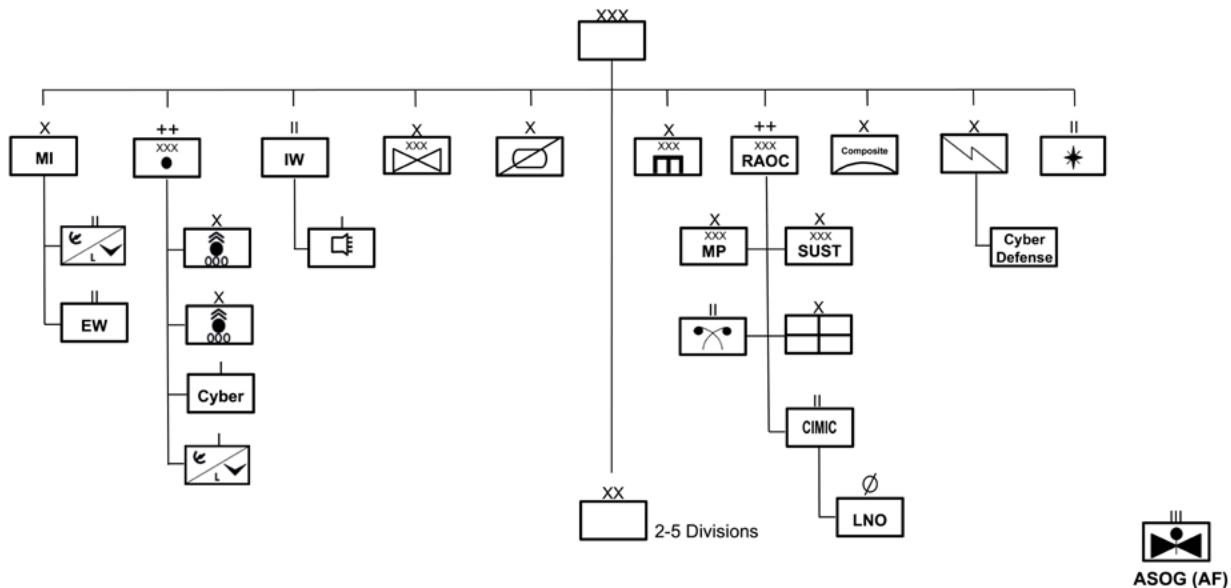

Note: Space Battalion includes high altitude companies for use as ISR or signal platforms

(Figure by Cpls. S. de Vries and N. Noordermeer, 1 [GE/NL] Corps REPRO Office)

## Figure 1. 1 (GE/NL) Corps Structure

- 1 x space battalion (includes high-altitude companies for use as ISR or signal platforms)
- Other forces may be assigned, attached, or provided operational control to give the corps additional capabilities) or additional capacity.<sup>5</sup>

Much of the structure above may sound familiar.

However, based upon analysis conducted by 1 (GE/NL) Corps, this structure is better optimized to penetrate and dis-integrate the integrated air defense systems (IADS) and the integrated fires complex (IFC) that could challenge NATO forces in the Euro-Atlantic area. The presence of substantial long-range fires systems provides the corps with an organic capability to engage enemy fires systems and support assigned forces or other component commanders if conflict should occur. The corps's capability to link a greater number of sensors than in the past, located throughout the depth of an expanded battlefield, to specific shooters enables it to converge capabilities in support of operational objectives and enhances the deterrent effect of Alliance ground forces.<sup>6</sup>

A key formation within the corps is the corps fires command, which integrates joint, interorganizational,

and multinational targeting capabilities. The corps fires command plans, coordinates, and delivers joint all-domain fires to shape operations. The scale and scope of operations against a peer enemy generally necessitates multiple brigades of long-range rockets and missile systems. Two assigned field artillery brigades provide the corps with the means to defeat an enemy's long-range and midrange fires and IADS to enable divisional tactical operations and freedom of maneuver for the Alliance joint force.<sup>7</sup>

Unlike a U.S. Army corps, a NATO corps does not fall under a standing theater army with organic capabilities or have subordinate divisions with a common and standardized divisional structure. Depending on the composition of the corps's higher echelon and subordinate divisions and brigades, the corps may require additional capabilities or capacity. These capability gaps are most likely to be found in electronic warfare (EW), fires, ISR, and intelligence. During Article 5 operations, divisions will require additional assets to assist in converging effects from multiple domains. While the corps does not own space or special operations assets and its



organic cyberspace capabilities are limited, it does possess the necessary tie-ins and expertise to integrate these domains into its operations. As the critical echelon in the execution of MDO, the corps will need the capacity to provide concurrent support to multiple divisions.<sup>8</sup>

## Role of the Corps

1 (GE/NL) Corps is a multinational headquarters assigned to NATO. Therefore, NATO-compatible equipment (e.g., communication and information systems), and NATO processes and procedures (e.g., the operations planning process; data management platforms; and Allied Procedural Publication 28, *Tactical Planning for Land Forces*) will be used. It can translate operational inputs into tactical outputs. It synchronizes maneuver, fires, and effects with the requisite maneuver support and sustainment to shape the environment for subordinate forces to accomplish tactical missions and achieve operational and strategic objectives. This is accomplished through planning and mission orders to subordinate forces, making the best use of their capabilities and capacities while enforcing unity of command and achieving unity of effort.

To defeat the enemy, the corps executes five functions. It

- ◆ shapes the enemy forces in the corps deep area with available corps and joint capabilities;
- ◆ maneuvers divisions and other combat formations to gain positions of advantage to close with and defeat enemy forces and compel their surrender or withdrawal, synchronizing the maneuver of divisions and, if necessary, brigades to reduce friction and coordinating the simultaneous maneuver of multiple formations in time and space;
- ◆ initiates, executes, implements, ensures, and supports consolidation activities to set conditions for transition to a sustainable political end state;
- ◆ sustains close, deep, and consolidation operations; and
- ◆ generates combat power through reception, staging, onward movement, and integration; and reconstitution.

The corps sets the conditions for subordinate divisions to focus on the close fight by integrating all elements of combat power in time and space to disrupt, interdict, and degrade the enemy while shaping the operating environment and enabling friendly forces to ensure freedom of action at the expense of its opponent. While the corps leverages Alliance joint capabilities to

achieve effects in its area of operations, it is fundamentally a tactical and land-centric formation.<sup>9</sup>

In the conduct of its operations, it is essential that the corps sets an operational tempo that does not permit the enemy to recover and establishes an inexorable momentum using echeloned maneuver to ensure that once contact is gained, it is maintained. The corps feeds forces into the main battle area and controls the dispersion and mass of maneuver units. Divisions do the same at their level. The corps enables operational tempo at the division level by keeping enemy space, cyber, air defense, and long-range and midrange fires under constant pressure. This allows the divisions to finish decisively once they gain contact with the enemy. Momentum and tempo are vital and are metrics the corps commander uses to gauge success.<sup>10</sup>

Momentum and tempo are the threads that run through the corps's operations and ensure that the enemy faces a continuous onslaught of simultaneous multi-echelon convergence.

**Lt. Gen. Andreas Marlow, German Army**, is the commander of the NATO Rapid Deployment Headquarters, 1 German-Netherlands Corps. He has commanded at every level in the German Army. Marlow deployed as the Chief of Staff of the German contingent within NATO's Kosovo Force mission, Deputy Chief of Staff-Operations Regional Command North International Security Assistance Force, and as the Chief of Staff Headquarters Resolute Support in Afghanistan. He is a graduate of the University of the Bundeswehr Hamburg, the German General Staff Officers Course, and the Command and Staff Course at the Canadian Forces College.

The importance of controlling the pace of operations challenges command and control because the corps must maintain forces not in contact to ensure fresh forces can reinforce success. The side that sets an overwhelming tempo

**Lt. Col. Wilson C. Blythe Jr., U.S. Army**, is a strategist in the G-5 Plans of the 1 German-Netherlands Corps. He holds a bachelor's degree in history from the University of Mississippi and a master's degree in history from Eastern Michigan University. Blythe is a recipient of the Army Historical Foundation's Distinguished Writing Award. His service includes deployments to Iraq and Afghanistan.



German and Dutch soldiers coordinating their route during NATO exercise Green Griffin 2021 in Lehnin, Germany. (Photo courtesy of 1 [GE/NL] Corps Public Affairs Office)

will win. However, the speed component of tempo is not just speed of decision but also the cumulative speed of all our actions from planning and issuing orders to executing movements, fire missions, and transmitting decisions.<sup>11</sup>

Given the nature of the threats posed to the Euro-Atlantic area, an MDO-capable NATO corps must maintain joint, interservice, and multinational relationships to facilitate the quick transition to conflict. These relationships help prepare the corps for its role as the senior land tactical headquarters and are developed and maintained through multi- and bilateral training events and exchanges as well as the multinational layout of the headquarters itself. 1 (GE/NL) Corps emphasizes and trains the comprehensive approach in all phases of competition, conflict, and postconflict.<sup>12</sup>

The presence of a corps and its subordinate units serves as a deterrent force capable of simultaneously engaging multiple enemy combined arms armies and provides the means to shape the area of responsibility. During competition, the conduct of intelligence activities

to set the conditions for successful combat operations will be a major focus of the corps. This work is essential to establishing the preconditions not only for a rapid transition to conflict but also for the achievement of tactical objectives. This includes the conduct of the threat systems analysis and comprehensive understanding of the operational environment (CUOE) necessary to support the convergence of Alliance, national, and organic assets necessary to achieve the desired effects against the enemy's sophisticated and resilient layered standoff.<sup>13</sup>

The corps denies/deters the ability of an enemy's ISR and EW systems to target NATO formations and facilities to gather information about capabilities. In addition, as deception is a key function of the corps, it will focus on deceiving and denying an adversary's access to information related to current and future operating locations, units, and equipment.

To achieve decisive effects on an enemy during combat operations, the corps synchronizes and integrates combat power throughout the expanded battlefield. The

ability of the corps to shape the lower operational and upper tactical environments is especially vital to Alliance operations during the initial period of a conflict when enemy long-range IADS will deny, or at a minimum contest, the Alliance's use of the air domain. The contribution of the corps to the penetration and dis-integration of the enemy's layered standoff is essential to generating freedom of maneuver for the Alliance joint force.<sup>14</sup>

During Article 5 or warfighting operations, the focus of the corps is on the conduct of the fight in the deep area with the objective of collapsing the enemy's long-range and midrange IFC and IADS. The MDO-capable NATO corps utilizes an array of interconnected sensors—artillery delivered, UAS, cyberspace, space, and infiltrated—that place enemy systems at risk. These allow the corps to employ its long-range artillery to destroy targets throughout the depth of the corps area of operations. It is important to remember that this is not a targeting drill; these mid- and long-range enemy systems are attacked to enable maneuver and freedom of action. Only by defeating the enemy's layered standoff will the Alliance be able to apply its air assets and will the corps's subordinate divisions get to the close fight with the combat power to prevail.<sup>15</sup>

The corps is the central echelon in the planning and execution of MDO and is the lowest echelon capable of converging all domains. It creates the conditions for convergence at lower echelons by allocating resources, sequencing division maneuver, and incorporating it with deception. Especially within NATO, the corps will be the primary integrator and synchronizer of multi-domain capability in the forward conflict area and will array assigned capabilities to defeat enemy systems and enable tactical maneuver.

Much as it does with the air and maritime domains, the corps coordinates for—it does not execute—and integrates effects from the space and cyberspace domains through space and cyber support teams embedded in the command. These include effects to disrupt satellite communications to compound effects by organic EW against key command-and-control nodes to degrade enemy positioning, navigation, and timing, cyberspace and space-based ISR, and offensive cyberspace operations. Though the corps may not have the organic capabilities in all domains, it must possess the ability—to include the necessary staff bandwidth and expertise—to access effects from the space, cyberspace, and other domains.

By synchronizing all reconnaissance and security operations across subordinate units, coordinating intelligence requirements, and fusing intelligence from multiple echelons, the corps supports echeloned maneuver and actively informs and integrates the full range of capabilities in all domains throughout the depth of the battlefield. Additionally, the corps unburdens subordinate formations by narrowing their focus, reducing their span of control, and maintaining the broader perspective in time and space, across the expanded battlefield. The planning horizon of a corps is typically seventy-two to ninety-six plus hours.<sup>16</sup>

While the corps's focus is on the deep area, and much has evolved with MDO, the corps still supports division-level tactical maneuver. In the close fight, it will support its major subordinate units by reinforcing them with forces, especially in the main effort (*Schwerpunkt*) and by applying joint effects, fire support, air and missile defense, and to a limited extent, cyber defense. The corps will have to conduct information activities and additional stability tasks as well. The ability of the corps to provide this support to its subordinate divisions is especially critical in a multinational setting where the structure and capabilities of its subordinate divisions can greatly vary.<sup>17</sup>

To preserve the corps's freedom of action for operations in the deep and close areas and to extend the force's operational reach, in part through the generation or reconstitution of combat power, the corps must provide security in the rear area to prevent or minimize disruption of combat support and combat service support from the rear area forward and provide unimpeded movement of friendly forces throughout the rear area. To do this, the corps must be able to find, fix, and defeat enemy incursions into the rear area. This will require close coordination with host-nation defense and security forces, and nonmilitary actors.<sup>18</sup>

The corps must wage this fight to protect its formations in the rear and close areas while simultaneously waging a fight in the deep area to set conditions for exploitation, and it must manage forces out of contact to ensure exploitation can be sustained and reinforced. The corps must provide for the echelonment of formations to ensure depth and agility to maintain tempo once a penetration occurs.<sup>19</sup>

The corps protects its subordinate tactical formations from attacks originating in other domains. Especially



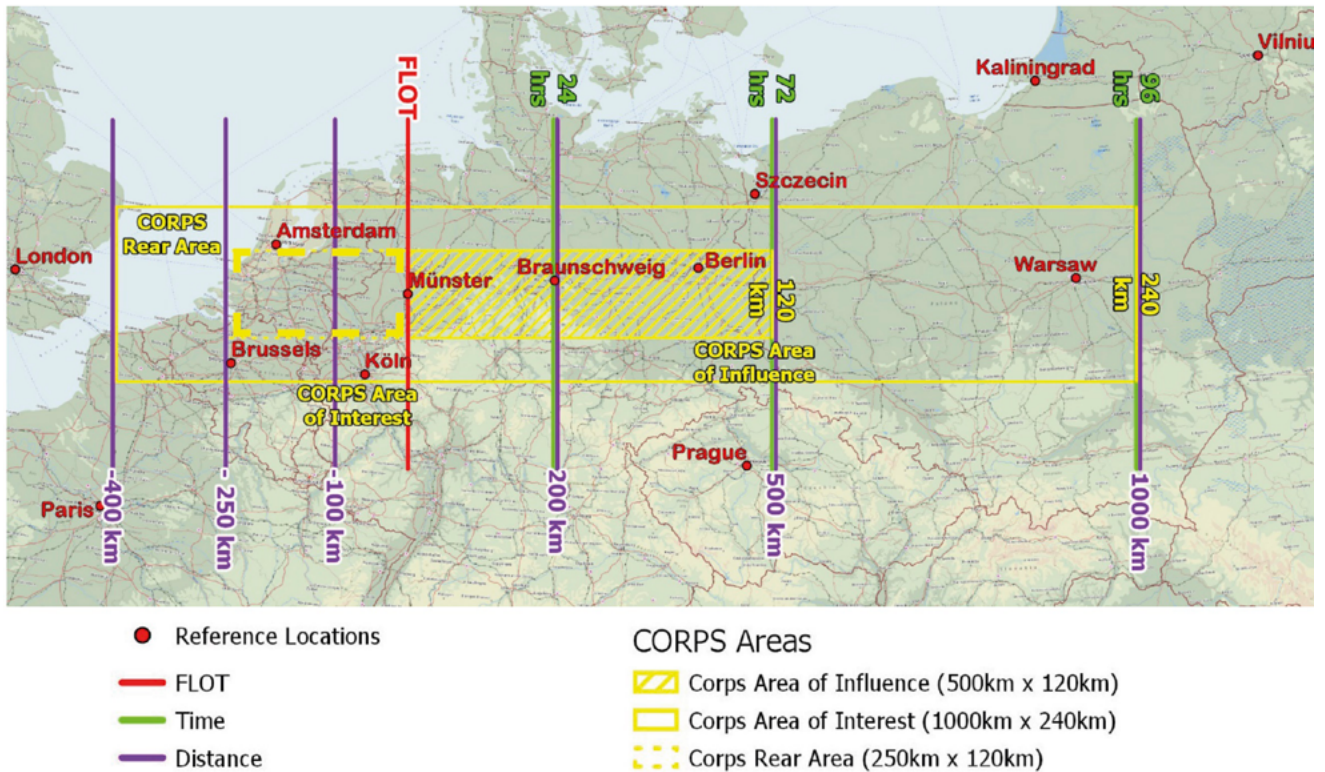

(Note: Lines are illustrative and not adapted to the terrain. Figure by Oberstabsfeldwebel Björn Ehlenberger, GIS NCO, 1 [GE/NL] Corps)

**Figure 2. Corps Battlefield Geometry**

important is the requirement to provide air and missile defense against the enemy's substantial inventory of artillery and ground- and air-launched missiles. This will enable the divisions to engage in the close fight with favorable combat power ratios. To do this, the corps must not only possess the necessary air and missile defense assets but also incorporate deception and electromagnetic spectrum management into its operations. The main effort will be on proactive counterfire.<sup>20</sup>

To succeed, the corps must set the conditions prior to conflict (i.e., in competition). Especially important is the continuous conduct and refinement of the robust CUOE of the enemy required to understand its key systems so the corps can begin the penetration and dis-integration of the enemy's mid- and long-range IADS and IFC during the transition to conflict. Vital to the success of these efforts is the corps's ability to exercise command and control throughout the depth of the expanded battlefield. To command and control throughout the entirety of its area of operations, the corps will employ

a distributive command post structure using multiple, dispersed, and mobile command posts.<sup>21</sup>

The corps area of operations and responsibility can extend up to 500 km deep and includes multiple echelons of tactical- and operational-level adversarial capabilities. Figure 2 illustrates how a corps operates across more than 60,000 km<sup>2</sup> during large-scale combat operations. Assuming the corps consists of two divisions abreast, the area of operations for the corps could be 500 km x 120 km. In consequence, the corps area of influence would extend out 500 km/72 hrs., while the corps area of interest would extend out to 1,000 km/96 hrs.<sup>22</sup> In this example, the corps rear area extends 200 to 250 km to the rear of the forward line of own troops.<sup>23</sup>

## How the Corps Fights

**Corps during competition.** During competition, the corps focuses on preparing to conduct operations in its potential area of operations. This entails rigorous

planning to enable it to rapidly deploy to its area of operations and defeat possible enemy military forces in combat operations. This planning is based on a rigorous and continuous CUOE that results in the necessary appreciation of the terrain, information environment, and understanding of likely enemy actions and capabilities to the systems level. This CUOE informs not only the corps but also its subordinate formations. Because of the increased complexity and resiliency of enemy systems, this work during competition is a prerequisite for successful operations during conflict.<sup>24</sup>

One of the corps's missions in competition is to enhance the conventional deterrence capabilities of NATO through its demonstrated proficiency in executing MDO. During competition, the corps trains to achieve the necessary expertise in MDO so that it can defeat equivalent enemy combined arms formations. The corps must regularly exercise the employment of capabilities from not only the air and maritime domains but also the space and cyberspace domains to stimulate, see, and strike enemy capabilities—especially long- and mid-range IFC and IADS.

Through the conduct of cooperative engagements, participation in multinational training exercises, and military-to-military partnerships, the corps can develop relationships with other Alliance forces and the interagency, enhancing the capabilities and interoperability—both conceptual and technical—of all involved. These exercises also allow the corps to practice sustaining itself and work out the details needed to deploy, sustain, and reconstitute a combat-ready force. In addition, exercising sustainment of the corps helps to build relationships with host nations and other entities that will be invaluable in the event of conflict. Developing the corps's ability to conduct MDO is critical to interoperability with U.S. formations and therefore to the Alliance's ability to deter aggression and support NATO information operations.<sup>25</sup>

The routine deployment of the corps and subordinate formations to conduct training and exercises makes their deployment during times of tension less complicated and escalatory. As tensions rise, forward-presence corps forces can rapidly reposition to dispersed locations and conduct multi-domain deception operations to complicate enemy targeting and decision-making activities. The creation of multiple, to include false, pictures in the electromagnetic spectrum aids in deceiving the enemy.

It slows down his ability to identify and target friendly formations and command posts. The complexities of planning for deception at the scale required do not reside in any echelon lower than the corps.

The corps and its subordinate formations must be capable of rapid deployment, transition to combat operations, and fighting a very intense battle on short notice. The corps will most likely not be allowed to conduct an uncontested deployment and build-up of combat power. Instead, it will be contested as it maneuvers from its peacetime location to its assigned area of operations where the corps will likely proceed directly into contact. This initial battle will be part of a campaign because modern militaries are too resilient to be defeated in a single battle. Success in this initial battle is vital to setting conditions for the rest of the campaign and posturing NATO for a favorable conclusion to the conflict.<sup>26</sup>

#### **Corps during penetration and dis-integration.**

Even prior to the initiation of open hostilities, NATO forces will likely be operating inside the umbrella of a peer enemy's IADS and IFC. With the beginning of open conflict, their IADS and IFC will impede key elements of the joint force so that they will not be able to support Alliance ground operations, or at least will have their operations severely degraded. Instead, Alliance land forces must conduct operations in support of forces of other domains so that the full weight of the Alliance's capabilities can be brought to bear on the enemy.

In practice, this will mean that at the onset of operations, the corps can expect limited support from the air and maritime domains. The campaign against an enemy's long- and mid-range systems will likely be waged primarily by land-based fires. Unlike during the Cold War, when such a capability resided in NATO's field armies, today's operational echelon is absent such a capability, which means that the corps with its corps fires command will be responsible for enabling the freedom of action for the Alliance's joint force.

Although on the move, the corps fires command provides on-order support to augment the operational echelon's operations to destroy high-value targets and degrade enemy long-range fires and air defenses. As soon as the enemy's IADS is dis-integrated, NATO can employ greater quantities of fifth-generation aircraft until these enemy systems are eventually collapsed and fourth-generation aircraft can be unleashed against



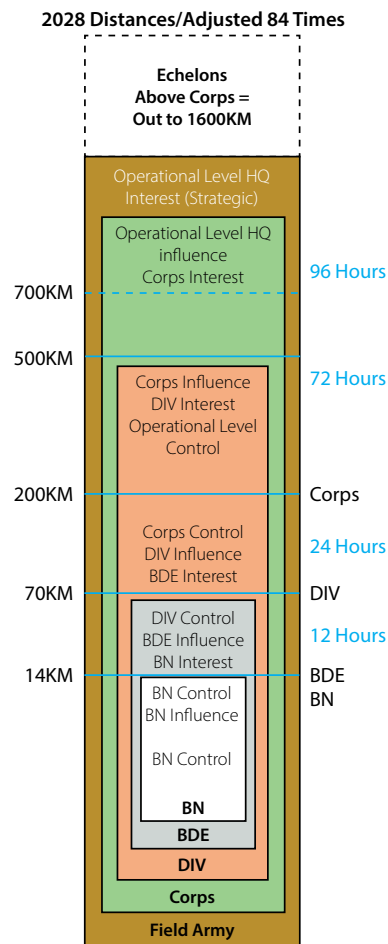
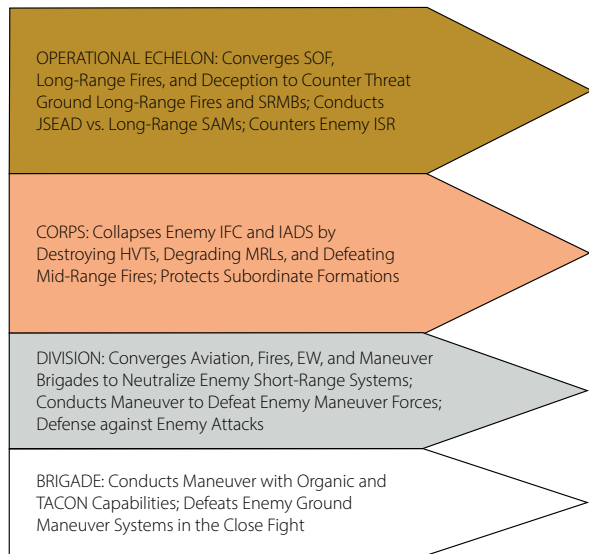

(Figure by Cpls. S. de Vries and N. Noordermeer, 1 [GE/NL] Corps REPRO Office)

### Figure 3. Fighting by Echelon

enemy ground forces. As the weight of air assets that NATO is allowed to commit against enemy ground forces increases, the corps fires command can shift the priority of its fire support assets to defeat the enemy’s mid-range fires systems and to support its maneuvering divisions (see figure 3).

In addition, the corps maneuvers to seize objectives and defeat enemy forces. The corps will employ a covering force to attrit enemy maneuver forces and gain intelligence about the strength and direction of potential attacks. Just as importantly, this covering force will compel the enemy to deploy his forces and mount an attack. This will slow the rate of the enemy’s advance, thus gaining time for the corps to bring additional combat power into the fight and for NATO’s campaign against the enemy’s IADS to create windows of opportunity for the employment of air and maritime assets.

The ability to conduct multiple wet-gap crossings will be critical to the success of the corps. It is estimated that land forces operating in eastern or central Europe will have to conduct a wet-gap crossing of a small (six-meter wide) water obstacle every twenty kilometers, a medium size (one hundred-meter wide) river every thirty-five to sixty kilometers, and a large river (one hundred to three hundred meters wide) every 100 to 150 kilometers. The ability to conduct a succession of these wet-gap crossings is essential to the corps’s ability to maintain the necessary momentum.<sup>27</sup>

As the corps maneuvers, likely from

its peacetime locations toward its area of operations to assume control of the tactical-level fight, it is liable to commit forces to the fight as they become available in order deny enemy military objectives or at a minimum extend the timeline it takes enemy forces to seize them, thus allowing NATO to commit more combat power to the fight. Under these chaotic conditions, habitual, or preferably formalized and permanent, relationships will be critical to the corps performance and cohesion.<sup>28</sup>

With limited forces initially available, the corps is responsible for preserving its combat power to enable success in close combat operations by conducting survivability, multi-domain deception, and obsuration operations. It is responsible for the protection of subordinate formations as well as forward-deployed divisions as they maneuver to close with enemy forces. Additionally, the corps prepares to receive additional

forces as they deploy to the area of operations.

In contrast to the linear forward deployment of NATO corps during the Cold War, today's NATO corps must be prepared to conduct noncontiguous defense spread out from front to rear over many kilometers. Given the ratio between space and forces available, there cannot be anything approaching a continuous line of defense as this would be too brittle. The corps will use complex terrain as strongpoints to bolster the resiliency

of its defense. This defensive battle will require a great deal of offensive action with opportunistic counterattacks to defeat exposed enemy forces and dislocate an enemy offensive.<sup>29</sup>

Throughout the fight, the corps must extract sufficient forces from the fight to form a reserve large enough to influence events; this applies to both when the corps is attacking and defending. Forming a reserve will be especially difficult in the initial phase of the battle when the disparity of forces will be at their greatest, but the more difficult it is, the more necessary it will be. The corps must balance denying an enemy from achieving its military objectives with the need to preserve sufficient combat power.<sup>30</sup>

Success by the corps and its subordinate formations or setbacks or failures by the enemy, and contradictions between words and deeds will be highlighted by information operations at the corps and higher echelons. To be relevant and effective, information operations must always be tied to the physical domains. The success of information operations, especially that rooted in "propaganda of the deed," will be a critical component of securing battlefield gains.<sup>31</sup>



A Dutch soldier from the Rapid Response Forces Division scans the area during a scouting mission as part of the NATO exercise Green Griffin 21 on 4 October 2021 at Lehnin, Germany. Green Griffin is an annual NATO training exercise designed to increase the scale, capability, and interoperability of NATO allies and partner forces. The exercise involved elements from the U.S. Army's 12th Combat Aviation Brigade, the Bundeswehr's Rapid Response Forces Division, the Netherlands Air Force, and the Romanian Army's Mechanized Brigade. (Photo by Michele Wiencek, U.S. Army)

**Corps during exploitation.** The corps is the senior NATO headquarters level responsible for directing the tactical fight. It will converge the capabilities of its operational and subordinate divisional fires assets with space, cyber, and special operations assets along with air assets to stimulate, see, strike, and assess targets in the close combat area. The neutralization of an enemy's first and second echelon mid-range fires systems will allow the corps's divisions to isolate and defeat the leading elements of the attacking enemy's first echelon. With the defeat of these forces, the corps can exploit the successes with its available divisions.

The corps's aviation brigade will perform multiple roles. The attack assets will be available to execute deep strikes and to perform area of operations-wide security tasks. Because of the abundance of a peer enemy's air defense systems, deep strikes by attack aviation will most likely be conducted at night with smaller groups of aircraft using terrain masking for protection as they approach their objective. It is unlikely that these attacks will be conducted to the full depth of the corps area of influence—those will most likely be conducted with long-range or joint fires. Use of lift assets will support

sustainment operations throughout the area of operations. Intelligence assets in conjunction with signal assets will cross-cue with corps fires command and/or corps aviation brigade UAS to provide targetable data via the integrated fires network for strikes by the corps fires command. Organic or attached intelligence assets will utilize employed sensors to see and track displacing enemy's elements to enable follow-on engagement.

The corps's responsibility for protection of the Alliance's tactical formations continues to be crucial to the success of operations. To follow up success obtained in isolating the lead elements of the attacking enemy formations, the corps needs to be able to exploit advantages gained by the Alliance. To enable continued success, it must provide its units the necessary support to conduct operations against an enemy's ground forces that result in a return by enemy forces to their territory and their assumption of a less threatening posture.<sup>32</sup>

**Corps during de-escalation and return to noncrisis competition.** The highest priority of the corps remains the direction of the tactical fight against a peer enemy's forces. The corps will continue to focus on defeating enemy maneuver forces, the denial of key objectives, and the establishment of positions that give NATO an advantage during negotiations to end the conflict.

The corps fires command, supported by divisional fires assets, continues to conduct operations to neutralize and/or defeat enemy mid- and short-range fires. This sets the conditions for the corps to continue to maneuver its subordinate divisions as they execute the close fight against enemy maneuver forces. The corps and its subordinate units maintain, protect, and secure lines of communication with dedicated assets, masked by obscurity and deception operations to ensure survivability. The adequacy of support to ensure success in the form of personnel, equipment, and supplies cannot be understated. Additionally, the corps conducts reconstitution operations to regenerate combat power and begins the integration of any still deploying units into combat operations and consolidation efforts.

The focus of operations shifts to the corps as violence subsides during the consolidation of gains. The corps initially conducts deliberate planning and preparation to consolidate gains following the tactical success of its subordinate divisions. While eventually

divisions, and at the completion of large-scale combat, all units conduct activities to consolidate gains, the corps is responsible for overall planning, preparation, execution, and assessment to allow divisions to remain focused on retaining the initiative and maneuvering without a loss of momentum. Consolidation of gains entails those activities that, combined, make temporary tactical successes enduring; therefore, winning the close fight—tactical success—is of first importance. However, the tactical success will have been in vain without full and continuous consideration to the consolidation of operational and strategic gains. Activities to consolidate gains require a balance between security and stability tasks as well as influencing key audiences to support coalition and host-nation political and security forces operating in the area of operations. The corps, with augmentation, may transition to a joint task force designed to coordinate with interagency partners from various NATO nations and international organizations to begin extensive reconstruction and restore essential services. It may be required to remain in the theater for a significant period to ensure stability while retaining the capability to renew offensive operations rapidly should hostilities resume.<sup>33</sup>

## Conclusion

The ability of 1 (GE/NL) Corps to fulfill the warfighting corps role in the conduct of large-scale combat operations underpins the credibility of the Alliance's deterrence. However, to successfully deter or prevail in armed conflict, 1 (GE/NL) Corps and the other graduated readiness forces (land) need to continue to develop the required capabilities at the capacity needed to be a capable of conducting large-scale combat operations. The ability to employ these formations as described earlier requires realistic training and exercises that approach the intensity of modern operations, and finally, an aggressive warrior mindset focused on defeating any potential enemy. This is different from previous experience in non-Article 5 operations in which a greater emphasis was placed on other qualities and capabilities. The more professional we become in fulfilling the warfighting role, the more credible our efforts will be. In short, readiness and demonstrated warfighting competence are the foundation of effective deterrence.



Today again, deterrence is the key to preventing conflict because an aggressor must realize that the consequences for violent acts would be his defeat. NATO will remain the most powerful military alliance that

has ever existed in history. If we maintain our cohesion, no potential enemy will be able to successfully attack any alliance member. 1 (GE/NL) Corps will continue to provide its contribution in this context. ■

## Notes

1. 1 (GE/NL) Corps, "Corps Vision" (2019).
2. 1 (GE/NL) Corps's path to achieve readiness as a Warfighting Corps is detailed in 1 (GE/NL) Corps OPLAN 2027.
3. NATO Standardization Office, s.v. "formation," accessed 2 March 2022, <https://nso.nato.int/natoterm/Web.mvc>. NATO defines formation as "an ordered arrangement of troops and/or vehicles for a specific purpose."
4. For example, the U.S. Army's AimPoint and WayPoint Force, or that found in Jack Watling and Sean MacFarland, *The Future of the NATO Corps* (London: Royal United Services Institute for Defence and Security Studies, 2021), accessed 2 March 2022, <https://www.ousa.org/sites/default/files/SR-2021-The-Future-of-the-NATO-Corps.pdf>.
5. This structure is detailed in the 1 (GE/NL) Corps discussion paper, *1 (GE/NL) Corps as a Warfighting Corps* (7 April 2021), and was validated through the Quick Rider series of exercises and studies conducted by 1 (GE/NL) Corps throughout 2021.
6. U.S. Army Futures Command (AFC) Pamphlet 71-20-1, *U.S. Army Concept for Maneuver in Multi Domain Operations 2028* (Fort Eustis, VA: Army Futures Command, 2020), 39, accessed 2 March 2022, <https://api.army.mil/e2/c/downloads/2021/01/20/2fbec-ccc/20200707-afc-71-20-1-maneuver-in-mdo-final-v16-dec-20.pdf>; 1 (GE/NL) Corps, *Warfighting Concept: The Conceptual Framework of Corps Operations* (2020), 14, 18; 1 (GE/NL) Corps, *Corps Operating Concept: The Conduct of Corps Operations* (2022), 25; U.S. Army Futures Command, *Executive Summary: The Battlefield Development Plan 2019, "Field Army, Corps, and Division in Multi-Domain Operations 2028"* (Fort Eustis, VA: U.S. Army Futures Command, Joint & Army Concepts Division, 2020), 2–3, accessed 2 March 2022, <https://www.armyupress.army.mil/Portals/7/military-review/Archives/English/JA-20/Executive-Summary-The-Battlefield-Development-Plan-2019-Finalv2.pdf>.
7. 1 (GE/NL) Corps as a Warfighting Corps.
8. Ibid., 25.
9. 1 (GE/NL) Corps, *Warfighting Concept*, 10, 50; Watling and MacFarland, *The Future of the NATO Corps*, 5, 9; 1 (GE/NL) Corps, *Corps Operating Concept*, 25.
10. 1 (GE/NL) Corps, *Corps Operating Concept*, 25.
11. Simultaneous multi-echelon convergence can be found in the AFC Pamphlet 71-20-1, *U.S. Army Concept for Maneuver in Multi Domain Operations 2028*, 22; 1 (GE/NL) Corps, *Corps Operating Concept*, 20, 21, 25, 40.
12. 1 (GE/NL) Corps, *Corps Operating Concept*, 25; 1 (GE/NL) Corps, "Corps Vision" (2019); German Army, *Truppenfuehrung* (May 2018), 35.
13. 1 (GE/NL) Corps, *Warfighting Concept*, 13, 25.
14. These lessons were validated during 1 (GE/NL) Corps Functional Integration Training (Deep Operations) and a series of map exercises conducted in 2021. They were codified in the 1 (GE/NL) Corps, *Corps Operating Concept*, 26; also see AFC, *Executive Summary: The Battlefield Development Plan 2019*, 3.
15. Ibid.; 1 (GE/NL) Corps, *Warfighting Concept*, 14–15.
16. 1 (GE/NL) Corps, *Corps Operating Concept*, 27; AFC Pamphlet 71-20-1, *U.S. Army Concept for Maneuver in Multi Domain Operations 2028*.
17. German Army, *Truppenfuehrung*, 50. Unlike a U.S. Army corps, 1 (GE/NL) Corps is multinational in the organization of its staff, corps troops, and subordinate formations for which there is no set common structure.
18. 1 (GE/NL) Corps, "Rear Area Concept" (draft); and lessons learned from the Battlespace Management Map Exercise conducted on 16 July 2021.
19. This is an expansion of the concept of echeloned maneuver found in AFC Pamphlet 71-20-1, *U.S. Army Concept for Maneuver in Multi Domain Operations 2028*.
20. 1 (GE/NL) Corps, *Corps Operating Concept*, 26, 40. This reflects lessons learned during Exercise Strong Rider conducted 14–16 June 2021.
21. This reflects lessons learned during Exercise Strong Rider conducted 14–16 June 2021.
22. 1 (GE/NL) Corps, *Corps Operating Concept*, 23; AFC Pamphlet 71-20-1, *U.S. Army Concept for Maneuver in Multi Domain Operations 2028*, 82.
23. 1 (GE/NL) Corps, *Corps Operating Concept*, 27; U.S. AFC Pamphlet 71-20-1, *U.S. Army Concept for Maneuver in Multi Domain Operations 2028*, 23, 25.
24. 1 (GE/NL) Corps, *Warfighting Concept*, 29.
25. German Army, *Truppenfuehrung*, 35.
26. Peter L. Jones et al., *Russian New Generation Warfare: Unclassified Summary of the U.S. Army Training and Doctrine Command Russian New Generation Warfare Study* (Fort Eustis, VA: U.S. Army Training and Doctrine Command, 2017), accessed 2 March 2022, <https://www.armyupress.army.mil/Portals/7/online-publications/documents/RNGW-Unclassified-Summary-Report.pdf>.
27. Les Grau and Charles Bartles, *The Russian Way of War: Force Structure, Tactics, and Modernization of the Russian Ground Forces* (Fort Leavenworth, KS: U.S. Army Foreign Military Studies Office, 2016), 311; 1 (GE/NL) Corps, *Corps Operating Concept*, 33.
28. 1 (GE/NL) Corps Discussion Paper, *1 (GE/NL) Corps as a Warfighting Corps* (7 April 2021).
29. German Army, *Truppenfuehrung*, 54; 1 (GE/NL) Corps, *Corps Operating Concept*, 34.
30. Ibid.
31. German Army, *Truppenfuehrung*, 63; 1 (GE/NL) Corps, *Corps Operating Concept*, 34.
32. 1 (GE/NL) Corps, *Corps Operating Concept*, 37.
33. Ibid., 39.