



# **Military Review**

THE PROFESSIONAL JOURNAL OF THE U.S. ARMY

MAY-JUNE 2022

**Building the Russian Concept of  
Operations in the Baltic Sea Region**

Wintermans and Cox, p6

**Multi-Domain Warfighting in NATO**

Marlow and Blythe, p16

**On Biological War**

Mauroni, p28

**The Tactical Considerations of Augmented  
and Mixed Reality Implementation**

Kallberg, Beitelman, Mitsuoaka, Pittman, Boyce, and Arnold, p105

# Military Review

THE PROFESSIONAL JOURNAL OF THE U.S. ARMY

May-June 2022, Vol. 102, No. 3

Professional Bulletin 100-22-05/06

Commander, USACAC; Commandant, CGSC; DCG for Combined Arms, TRADOC.

Lt. Gen. Theodore D. Martin, U.S. Army

Provost, Army University; DCG for CGSC: Maj. Gen. Donn H. Hill, U.S. Army

Director and Editor in Chief: Col. Jacob M. Brown, U.S. Army

Managing Editor: William M. Darley, Col., U.S. Army (Ret.)

Editorial Assistant: Vacant

Operations Officer: Maj. Jordan Bellamy, U.S. Army

Senior Editor: Jeffrey Buczkowski, Lt. Col., U.S. Army (Ret.)

Writing and Editing: Beth Warrington; Allyson McNitt, PhD

Graphic Design: Vacant

Webmasters: Michael Serravo; James Crandell, Kyle Davis, Dominic Graham—Contractors

Editorial Board Members: Rich Creed, Col., U.S. Army (Ret.)—Director, Combined Arms

Doctrine Directorate; Dr. Lester W. Grau—Director of Research, Foreign Military Studies

Office; Col. Sam Saine—Director, Center for Army Profession and Leadership; Col. Christopher J. Keller—Director, Center for Army Lessons Learned; Howard Brewington—Deputy

Director, MCCoE; Edward T. Bohnemann, Col., U.S. Army (Ret.)—Deputy, Combined

Arms Center-Training; Richard J. Dixon, Col., U.S. Army (Ret.)—Deputy Director, School of

Advanced Military Studies

Consulting Editors: Col. Ricardo Yoshiyuki Omaki—Brazilian Army, Portuguese Edition;

Maj. Zachary Griffiths, 10th Special Forces Group (Airborne), Special Operations;

Maj. Thomas Fox, International Affairs—Asian Affairs, USMA

Submit manuscripts and queries by email to [usarmyleavenworth.tradoc.mbx.armyu-aup-military-review-public@army.mil](mailto:usarmyleavenworth.tradoc.mbx.armyu-aup-military-review-public@army.mil);

visit our web page for author submission guidelines at <https://www.armyupress.army.mil/Publish-With-Us/#mr-submissions>.

*Military Review* presents professional information, but the views expressed herein are those of the authors, not the Department of Defense or its elements. The content does not necessarily reflect the official U.S. Army position and does not change or supersede any information in other official U.S. Army publications. Authors are responsible for the accuracy and source documentation of material they provide. *Military Review* reserves the right to edit material. A limited number of hard copies are available for distribution to headquarters elements of major commands, corps, divisions, brigades, battalions, major staff agencies, garrison commands, Army schools, reserve commands, cadet command organizations, medical commands, hospitals, and other units as designated. Information on subscriptions may be obtained by consulting *Military Review*, which is available online at <https://www.armyupress.army.mil/Military-Review/>.

*Military Review* (US ISSN 0026-4148) (USPS 123-830) is published bimonthly by the Department of the Army, Army University Press, Fort Leavenworth, KS 66027-1293. Periodical postage paid at Leavenworth, KS, and additional mailing offices.

Yearly paid subscriptions are for \$42 US/APO/FPO and \$58.80 for foreign addresses and are available through the U.S. Government Publishing Office (GPO) at <https://bookstore.gpo.gov/products/military-review-professional-journal-united-states-army>.

ADDRESS CHANGES: For personal subscriptions, contact GPO at 1-866-512-1800 or [contactcenter@gpo.gov](mailto:contactcenter@gpo.gov). For military units and other official government subscribers, contact [usarmyleavenworth.tradoc.mbx.military-review-public-em@army.mil](mailto:usarmyleavenworth.tradoc.mbx.military-review-public-em@army.mil).

The Secretary of the Army has determined that the publication of this periodical is necessary in the transaction of the public business as required by law of the department. Funds for printing this publication were approved by the Secretary of the Army in accordance with the provisions of Army Regulation 25-30.

By Order of the Secretary of the Army: Official:

**JAMES C. MCCONVILLE**

General, United States Army

Chief of Staff



**MARK F. AVERILL**

Administrative Assistant

to the Secretary of the Army

2209805



**Cover photo:** Soldiers with the 1st Battalion, 5th Cavalry Regiment, 2nd Armored Brigade Combat Team, 1st Cavalry Division, and multinational partner forces conduct a dry-fire rehearsal for a combined arms live-fire exercise in Galati, Romania, on 16 February 2020. (Photo by Staff Sgt. Noshoba Davis, U.S. Army National Guard)

**Next page:** The northern lights illuminate the sky over Buffalo Drop Zone at Fort Greely, Alaska, 20 March 2022. Joint Pacific Multinational Readiness Center 22-02 was the first regional combat training center rotation in Alaska that focused on large-scale combat operations. It was a cold weather training event that included a situational training exercise and a live-fire exercise. (Photo by Spc. Bradley McKinley, U.S. Army)



2022 General William E. DePuy

# Special Topics Writing Competition

## This year's theme is "Insights from Two Decades in Afghanistan"

The intent of this year's DePuy competition is to highlight from a "boots on the ground" perspective what specifically the U.S. Army should learn from its twenty-year experience in Afghanistan. Possible topics might include the following: What faulty assumptions did leaders at all levels make that should be avoided in the future? What lessons should future

senior military leaders learn from Afghanistan? How did the perception of success affect operational planning and assessments of progress? To what degree was Afghanistan a failure of mission-command or counterinsurgency doctrine? Any other salient topics that might be gleaned from an individual's experience and point of view.

**Cautionary note:** Over the course of the next several years, the topic of U.S. military involvement in Afghanistan will likely be intensely examined, debated, and heatedly argued; primarily at the strategic level and among a host of entities both in and out of the military. In contrast, while *Military Review* (MR) will consider all submissions received, the DePuy contest has historically been a venue that places a premium on careful, impartial, and scholarly work in the practical pursuit of applicable lessons learned. MR has selected the 2022 topic specifically to take advantage of the wealth of relatively recent experience still resident in the active-duty or just-retired force for the purposes of practical learning. Consequently, the judges will be advised that preference will be given to articles where authors primarily discuss issues that outline lessons learned salient to the operational and tactical levels of conflict. Authors are advised to avoid attempting to use the contest as a forum for partisan/political-oriented assignment of credit and liability for the outcome of the Afghanistan Campaign.

## Contest opens 1 January 2022 and closes 18 July 2022

1st Place	\$1,000 and publication in <i>Military Review</i>
2nd Place	\$750 and consideration for publication in <i>Military Review</i>
3rd Place	\$500 and consideration for publication in <i>Military Review</i>

For information on how to submit an entry, please visit <https://www.armyupress.army.mil/DePuy-Writing-Competition/>.

Articles will be comparatively judged by a panel of senior Army leaders on how well authors have clearly identified issues requiring solutions relevant to the Army in general and/or to a significant portion of the Army; how effectively detailed and feasible solutions to the problems identified are presented; and, the level of expository skill the author demonstrates in developing a well-organized article using professional standards of grammar, usage, critical thinking, original insights, and evidence of thorough research in the sources provided.

- 6**      **Building the Russian Concept of Operations in the Baltic Sea Region**  
**An Experimental Approach**  
Maj. Frederik Wintermans, Royal Netherlands Army  
Dan G. Cox, PhD  
*Much debate regarding Moscow's intentions in the Baltic Sea region preceded the quadrennial Russian military-strategic exercise ZAPAD-2021. With the backdrop of increasing NATO-Russia tensions over the past few years, some believe the Kremlin desires to seize and control the Baltic States.*
- 16**      **Multi-Domain Warfighting in NATO**  
**The 1 German-Netherlands Corps View**  
Lt. Gen. Andreas Marlow, German Army  
Lt. Col. Wilson C. Blythe Jr., U.S. Army  
*The ability to conduct large-scale combat operations underpins the credibility of NATO's deterrence and provides the basis for the defense of the Euro-Atlantic area in the event of conflict, and 1 (GE/NL) Corps must possess the ability to successfully perform the warfighting corps role.*
- 28**      **On Biological War**  
Al Mauroni  
*There has been no test of the U.S. military's biodefense capability, but the Nation's recent public health challenges in addressing the 2019 coronavirus pandemic (COVID-19) have caused questions as to whether the U.S. military is sufficiently prepared for an adversary that might be emboldened to use biological weapons against U.S. national security interests.*
- 38**      **A Mission of Mercy amidst Terror, Death, and Despair**  
**The Story of the National Relief Boat in the Great Yellow Fever Epidemic of 1878**  
Maj. James D. Campbell Jr., U.S. Army, Retired  
*The Army has been called upon to manage distribution, and in some cases the administration, of the vaccine in relief of the coronavirus pandemic, as well as other efforts in support of pandemic relief. However, as this article describes, designating the Army as a relief provider is not new or unique to this medical crisis.*
- 47**      **Protection of Civilians in Robust Peacekeeping Operations**  
**The Role of United Nations Special Operations Units**  
Maj. Josias Marcos de Resende Silva, Brazilian Army  
*Protection of civilians has become the most common standard for assessing the performance of UN peacekeeping. A Brazilian officer describes how, in response, the UN has recently adopted special operations units to enhance UN peacekeeping operations.*
- 58**      **The Strategic Competition for Partnership**  
**Inside Views from the Backbench: An Aide's Observations of Senior Leader Engagements**  
Capt. Sarah Melville, U.S. Army  
*An aide-de-camp provides insights into the inner workings of a senior leader's engagement preparation, execution, and follow-up gleaned from experiencing over seventy engagements between a deputy commanding general and leaders such as chiefs of defense, land component commanders, UN commanders, and ambassadors.*

**68 Assessing Mars**  
**A Holistic Framework for Land Forces Analysis**  
Chief Warrant Officer 2 Andrew L. Chadwick, PhD,  
U.S. Army National Guard  
*An intelligence analyst proposes a holistic framework for land forces analysis that fuses U.S. Army intelligence preparation of the battlefield techniques with methods employed by strategic intelligence organizations and military historians.*

**77 The Theater Army's Central Role in Integrated Deterrence**  
Maj. Justin Magula, U.S. Army  
*To counter growing threats from adversaries below the level of armed conflict, Army and joint leaders have placed increased emphasis on winning in competition short of armed conflict. Fortunately, the Army already employs an organization that can serve as the cornerstone of an integrated deterrence concept: the theater army.*

**90 Kicking the Beehive**  
**Reimagining Manned-Unmanned Teaming in Multi-Domain Operations**  
Capt. Clayton B. Jaksha, U.S. Army  
*An Army aviator opines that manned aircraft and unmanned aircraft system teaming will be decisive for Army aviation to penetrate, disintegrate, and exploit the enemy, but for it to be effective, the Army must make a materiel shift to swarming systems, embrace artificial intelligence in mission command and targeting processes, and reorganize into multi-domain formations at the platoon level.*

**98 How to Keep Changing an Army**  
**Adjusting Modernization in the Age of Loitering Munitions**  
Maj. Ryan Orsini, U.S. Army  
*Improved technology and tactics of massed loitering munitions in the hands of more formidable adversaries could dominate a future battlefield. To meet this challenge, the Army must pivot its modernization by adjusting how it organizes, experiments, and trains for change.*

**105 The Tactical Considerations of Augmented and Mixed Reality Implementation**  
Dr. Jan Kallberg  
Maj. Victor Beitelman, U.S. Army  
Maj. Victor Mitsuoka, U.S. Army  
Chief Warrant Officer 3 Jeremiah Pittman, U.S. Army  
Dr. Michael W. Boyce  
Lt. Col. Todd W. Arnold, U.S. Army  
*The integrated visual augmentation system provides an integrated suite of situational awareness capabilities to enable better decision-making and increase the tactical fighting ability of U.S. soldiers. However, there is a need to identify potential operational weaknesses in augmented reality/mixed reality systems.*

**114 History While It's Hot**  
**How a Group of U.S. Army Combat Historians Helped Preserve the GI's Perspective in Europe during World War II**  
Carson Teuscher  
*A military historian describes how, for the first time, the U.S. Army employed combat historians to record firsthand experiences of frontline combat infantry units.*

## REVIEW ESSAY

**126 The Other Face of Battle**  
**America's Forgotten Wars and the Experience of Combat**  
Donald P. Wright, PhD  
*The author critiques a book by Wayne E. Lee, Anthony E. Carlson, David L. Preston, and David Silbey in which the authors assess terrain, morale, care of casualties, and how U.S. arms and technologies fared against those of their adversaries during three battles from the American military experience.*

# Suggested Themes and Topics

## Large-Scale Combat Operations/ Multi-Domain Operations

- Division as a formation
- Air and antimissile defense
- Deep operations
- Information advantage/military deception
- Multi-domain task force
- Recon and security/cavalry operations
- Protection and security (air defense artillery, engineer, chemical, biological, radiological, nuclear, cavalry)

## Joint Operations

- Air/sea/land integration
- Joint/long-range precision fires
- Air and antimissile defense
- Joint forcible entry

## Europe/Central Command/ Indo-Pacific Command

- Contiguous and noncontiguous operations
- New operational environment: adversaries operating in their “near abroad” (close proximity to own borders)
- Peer and near-peer adversaries contesting U.S. joint force in all domains

## Other Topics

- What is the role for the Army/Reserve components in homeland security operations? What must the Army be prepared to do in support of internal security? Along our borders?
- Role of security force assistance brigades (SFAB) in the gray-zone competition phase drawn from experience of an SFAB in Africa or Europe
- What must be done to adjust junior leader development to the modern operational environment?
- What logistical challenges does the U.S. military foresee due to infrastructure limitations in potential foreign areas of operation, and how can it mitigate them?
- Defending against biological warfare—examination of the war waged by other than conventional military weapons
- The role of UAS and robotics at the tactical level
- Early lessons learned from the Russian invasion of Ukraine

Spc. Charles Sisino, a CH-47 crew chief assigned to the 12th Combat Aviation Brigade, “Wings of Victory,” performs airspace surveillance on 4 May 2021 from the ramp of his Chinook en route to the Bulgarian coast for maritime operations crew certification flights over the Black Sea during Exercise Swift Response 21, part of DEFENDER-Europe 21. (Photo by Maj. Robert Fellingham, U.S. Army)





Russian and Belarusian armed forces participate in joint strategic exercise ZAPAD-2021 on 12 September 2021 at a training ground in Belarus. The drills were held at nine training grounds in Russia, in the Baltic Sea, and at five training grounds in Belarus. (Photo by Henadz Zhinkov, Xinhua/Alamy Live News)

# Building the Russian Concept of Operations in the Baltic Sea Region An Experimental Approach

Maj. Frederik Wintermans, Royal Netherlands Army

Dan G. Cox, PhD



Much debate regarding Moscow's intentions in the Baltic Sea region preceded the quadrennial Russian military-strategic exercise ZAPAD-2021.<sup>1</sup> With the backdrop of increasing NATO-Russia tensions over the past few years, some believe the Kremlin desires to seize and control the Baltic States. On the one hand, Russian officials regularly dismiss such fears of NATO allies as anti-Russian "hysteria." For example, in March last year, Sen. Aleksey Pushkov said this hysteria is merely a pretext for NATO military expansion.<sup>2</sup> One of the best ways to examine Russian intentions is to analyze their largest military exercise conducted near the Baltic states, ZAPAD-2021. While military and intelligence agencies note Russian troop movements when they are clearly visible, none of the analysis of unit movements is put into a cohesive whole. Intelligence gatherers and military planners within NATO miss a vital opportunity to glean the operational approach that Russia may be signaling from such a large exercise. This article fills that hole by examining Russian tactical movements during ZAPAD-2021 and deducing what operational approaches are most likely from such an exercise. Strategic implications can also be speculated after operational approaches are described. Is Russia attempting to deter what it sees as further NATO aggression, or is Vladimir Putin rehearsing a potential incursion into one or more Baltic States? Answering important questions like these is a driving force behind this research.

The Russian General Staff conducted the active phase of ZAPAD-2021 from 10 to 16 September 2021. The exercise scenario allowed for practicing interoperability, training basic military tasks, and experimenting with new equipment on the battlefield. More importantly, the scenario permitted the General Staff to evaluate the contribution of tactical activities to the operational level of warfare.<sup>3</sup> Unfortunately, the body of knowledge on the Russian concept of operations in the Baltic Sea region is limited. Antiaccess/area denial (A2/AD), the gray zone, and the Gerasimov doctrine are topics of Russian military power that received intense scrutiny over the years.<sup>4</sup> However, if there is such a thing as an A2/AD strategy, a zone that is gray, or a doctrine designed by one person, they provide little utility to Western military planners and commanders in the Baltic Sea region. A better understanding of the

Russian concept of operations derived from the most recent ZAPAD-2021 exercise would be more helpful.

Building the outline of the Russian concept of operations in the Baltic Sea region allows military planners and commanders to increase understanding of its premises. Insufficient knowledge of the adversary's course of action is detrimental to success. A better understanding of Russian operational planning in the Baltic Sea region is critical because it partly determines the outcome of the unlikely event of an Article 5 scenario on NATO's eastern flank. Article 5 of the NATO charter states that "an armed attack against one or more of them in Europe or North America shall be considered an attack against them all."<sup>5</sup>

So, what is a concept of operations? According to the Joint Publication 5-0, *Joint Planning*, a concept of operations is "a verbal or graphic statement that clearly and concisely expresses what the commander intends to accomplish and how it

#### Maj. Frederik

Wintermans is an international student at the Command and General Staff College, Fort Leavenworth, Kansas. He is an infantry/military intelligence officer serving in the Royal Netherlands Army. His interests include nuclear weapons, escalation management, and operational planning.

Dan G. Cox, PhD, is a professor of political science for the U.S. Army School of Advanced Military Studies Program. He has three published books: *Terrorism, Instability and Democracy in Asia and Africa*, *Population-Centric Counterinsurgency: A False Idol*, and *Stability Economics: The Economic Foundations of Security in Post-Conflict Environments*. He has published in peer-reviewed journals such as the *Journal of Peace Research*, *Parameters*, the *International Journal of Public Opinion Research*, *Orbis*, *Interagency Journal*, *Special Operations Journal*, and *Congress and the Presidency*. His work has also appeared in journals such as *Joint Force Quarterly*, *Terrorism Monitor*, the *Strategy Bridge*, the *Art of Strategy*, and *Small Wars Journal*. Cox has also served in the NATO Partnership for Peace Program helping to improve the professional military education system of the military of the Republic of Armenia.

will be done using available resources.<sup>6</sup> We suggest a new approach to increase knowledge on the Russian concept of operations. First, using open sources, we sketch out a rough disposition of Russian units during ZAPAD-2021 and determine their tasking. Second, we outline the Russian concept of operations in the Baltic Sea region, drawing from Russian military thinking, the Russian force design and battlefield array, and unit tasking during ZAPAD-2021. Finally, we make recommendations for military planners and commanders to help them navigate the complex venture of operational planning.

The data collection method uses open-source outlets such as Russian newspapers, websites, and Twitter to determine the location and tasking of units during ZAPAD-2021. For example, the website [informnapalm.org](http://informnapalm.org) mentions the 76th Guards Air Assault Division (unit number 07264) training on the 230th All-Military Range in Obuz-Lesnovski.<sup>7</sup> Despite Russian media outlets having a bad reputation for disseminating disinformation, we assess open sources of this kind to be sufficiently valid. However, this approach has drawbacks. First, it is less precise than using intelligence agency assets. Second, it is a far cry from comprehensive. Nevertheless, for the purpose of this article, we assess it more than suffices. Further, intelligence agencies increasingly use open-source data to aggregate large amounts of relevant data easily.<sup>8</sup>

We do not consider cyber and information operations in this article, nor the space domain, in building the Russian concept of operations in the Baltic Sea region. Open-source data collection is not possible, but one can imagine Moscow using resources in these domains in any military conflict with NATO.

## Units and Tasks during ZAPAD-2021

The first two steps in our methodology for discerning the operational approach from the Russian ZAPAD-2021 exercise are determining disposition and unit tasking. Disposition of forces means determining the location of specific units that are the resources to execute a concept of operations. The benefit of knowing an opposing force's disposition is that it generates a clearer view of the adversaries' intention of the military operation. During ZAPAD-2021, the Russian General Staff deployed numerous units, and unfortunately, it is an impossible task to locate all of them. With its collection capabilities, generating the complete disposition

of all units deployed during ZAPAD-2021 is daunting even for the intelligence community. Nevertheless, a first glimpse of the disposition emerges from Russian social media, local newspapers, and the Russian Ministry of Defence website and is depicted in figure 1 (on page 9).<sup>9</sup>

The restriction of deploying to training ranges during ZAPAD-2021 limits the disposition value. After all, military units deploy wherever they are assigned a task in wartime. Two observations are interesting. First, consider the extensive use of the 1st Guards Tank Army elements in Belarus. Armor units are suitable for an offense with a high operational tempo. Their deployment in Belarus, near the borders of Poland and Lithuania, with just a short march to Kaliningrad, is no coincidence. Defense of Russian sovereign territory is a key element of the Kremlin's defense policy. Second, during ZAPAD-2021, there was a relatively large number of airdrops. Airborne operations help take control of vital terrain in enemy territory, which indicates offensive rather than defensive operations. They need a link up quickly with maneuver units because they lack proper sustainment. The combination of the 1st Guards Tank Army with the 76th Guards Air Assault Division indicates a counteroffensive in the scenario of ZAPAD-2021 that supports the defense of Russian territory. A tank army and an air assault division are primary ingredients for an offense from Belarus to Kaliningrad. For example, an airdrop in Kaunas, Lithuania, increases operational tempo.

The next step in our examination is to look at unit tasking. The authors assigned some tactical mission tasks in addition to the disposition and drawing from military theory and force design (see figure 2, page 10).

A key addition to Russian military thought, especially from Alexander Svechin, is the concept of the deep operation.<sup>10</sup> During the Cold War, Soviet planning provided for tank divisions to penetrate NATO defenses and race to the North Sea. Nowadays, the Russian General Staff does not have enough ground forces to reach the North Sea. Instead, for the deep operation, the concept of SODCIT is applied in planning: the strategic operations to destroy critically important targets.<sup>11</sup> Essentially, dual-capable cruise missiles and ballistic missiles fired from maritime, air, and ground platforms target airports, harbors, and political and military installations. The actual Russian target list is classified. But one can imagine



(Figure by authors)

### Figure 1. Generated Disposition of Forces Deployed during ZAPAD 2021

Green are the 1st Guards Tank Army elements, yellow are airborne troops, and light blue are military aircraft. The black hooks are defensive exercises of the Baltic Fleet and the 14th Corps. The top left picture is the mobile coastal defense system Bal, the bottom left is the 9K720 Iskandr, and the bottom right is the air-launched cruise missile KH-101/102.

rewarding targets like SHAPE headquarters, Joint Forces Command Brunssum, and NATO headquarters in Brussels. NATO is particularly vulnerable with these commands and headquarters as they have become static and are at well-known locations. As noted in figure 1, ZAPAD-2021 practiced launching the cruise missile KH 101/102, which is a resource for applying SODCIT. The rationale for a Russian deep operation against Western European targets is to degrade NATO command and control and delay the mobilization of NATO’s full military power. The Kremlin believes U.S. divisions pouring into Western European ports will tip the scales against them.

Unfortunately, one key element that has not changed in Russian operational planning is the reliance on nuclear

weapons. Almost all Russian precision-guided munitions are dual-capable: they can be equipped with a conventional or a nuclear warhead. This adds an existential threat to any Russian operation and may provide Moscow deterrence that prevents retaliation if they again, like they did in 2014, surprise the West by seizing all or part of another nation-state, even if it is a NATO member.

### Building the Russian Concept of Operations

We explored the disposition and the tactical unit tasks of some of the deployed Russian forces during ZAPAD-2021. These two ingredients provide insight into the last part of the definition of a concept of operations: how it will be done using available resources.

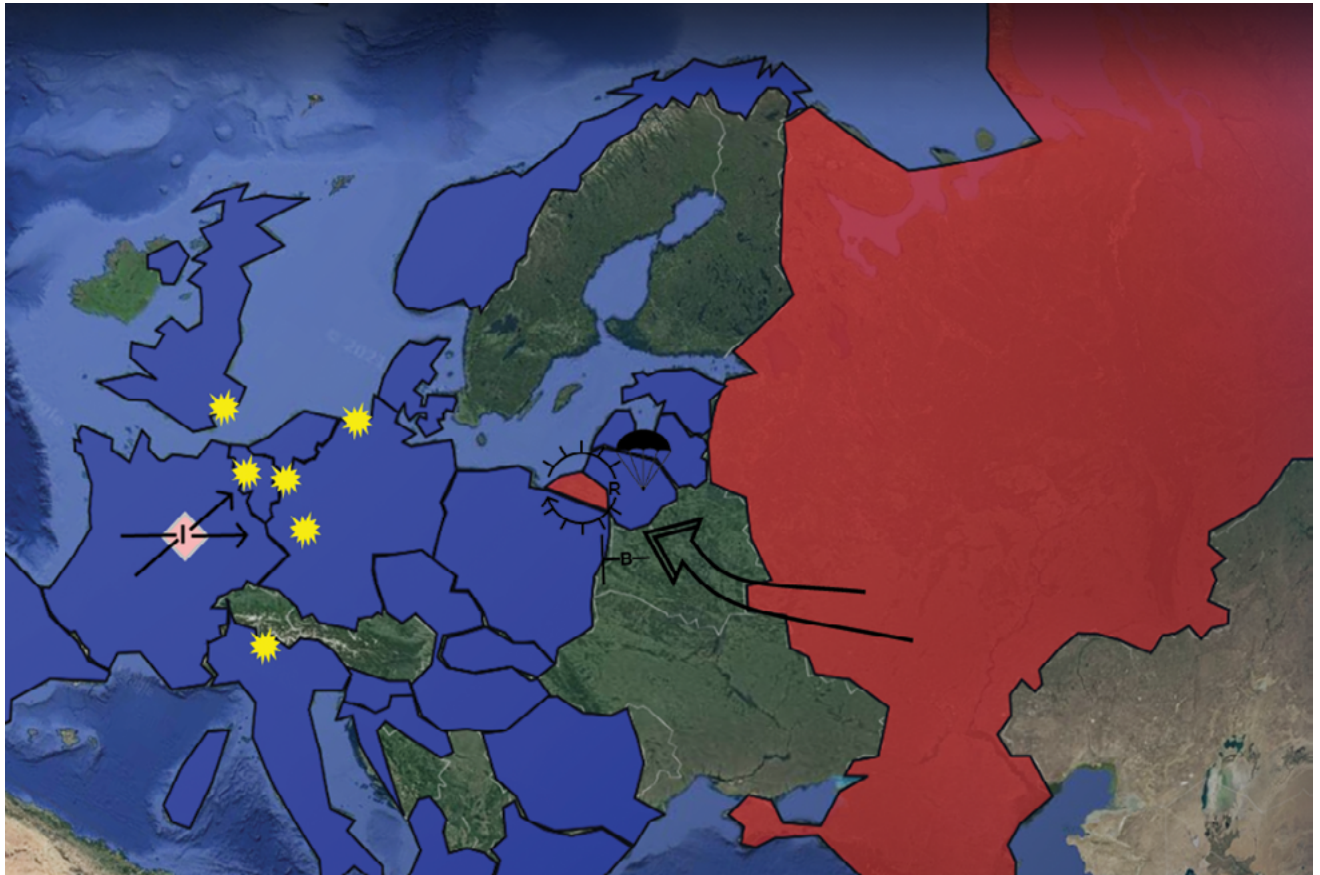

(Figure by authors)

## Figure 2. Tactical Mission Tasks Derived from the Disposition and the Tasks the Units Trained during ZAPAD-2021

The next step is to determine what the commander intends to accomplish. What does the commander of the Operational-Strategic Command West, Col.-Gen. Alexander Zhuravlyov, want to achieve when deterrence with the West breaks down? Some of the elements of operational design give insight into Zhuravlyov's intent.

**Phasing.** ZAPAD-2021 consisted of four phases, contrary to the two phases most analysts assume and the Russian military leadership briefs to the defense attachés indicated before the exercise: (1) preparation, (2) defense, (3) counterattack, and (4) nuclear escalation management.<sup>12</sup> Phases two and three occur during the active part of ZAPAD-2021 between 10 and 16 September. Still, the preparation began months before that, and the nuclear escalation management occurred in October during the GROM exercise (a rehearsal for nuclear warfare).<sup>13</sup>

**Decisive point.** Considering the concentration of forces in Belarus, northwestern Belarus is likely to be the decisive point in the concept of operations.

**Military end state.** Russia is a continental power, and virtually all its defense policy aims to defend the sovereignty of its territory. The territory most under pressure is Kaliningrad; thus, the military end state will likely be to relieve it.

**Objective.** An intermediate objective is likely key terrain between Belarus and Kaliningrad that serves as a diving board for the main effort toward Kaliningrad (see figure 3, page 11).<sup>14</sup> The achievement of this intermediate objective would trigger Article 5 of the NATO charter.

**Operational reach.** The operational reach of the deployed ground forces during ZAPAD-2021 is nowhere near sufficient to "invade" Western Europe. However, the deployed capabilities during ZAPAD-2021 can

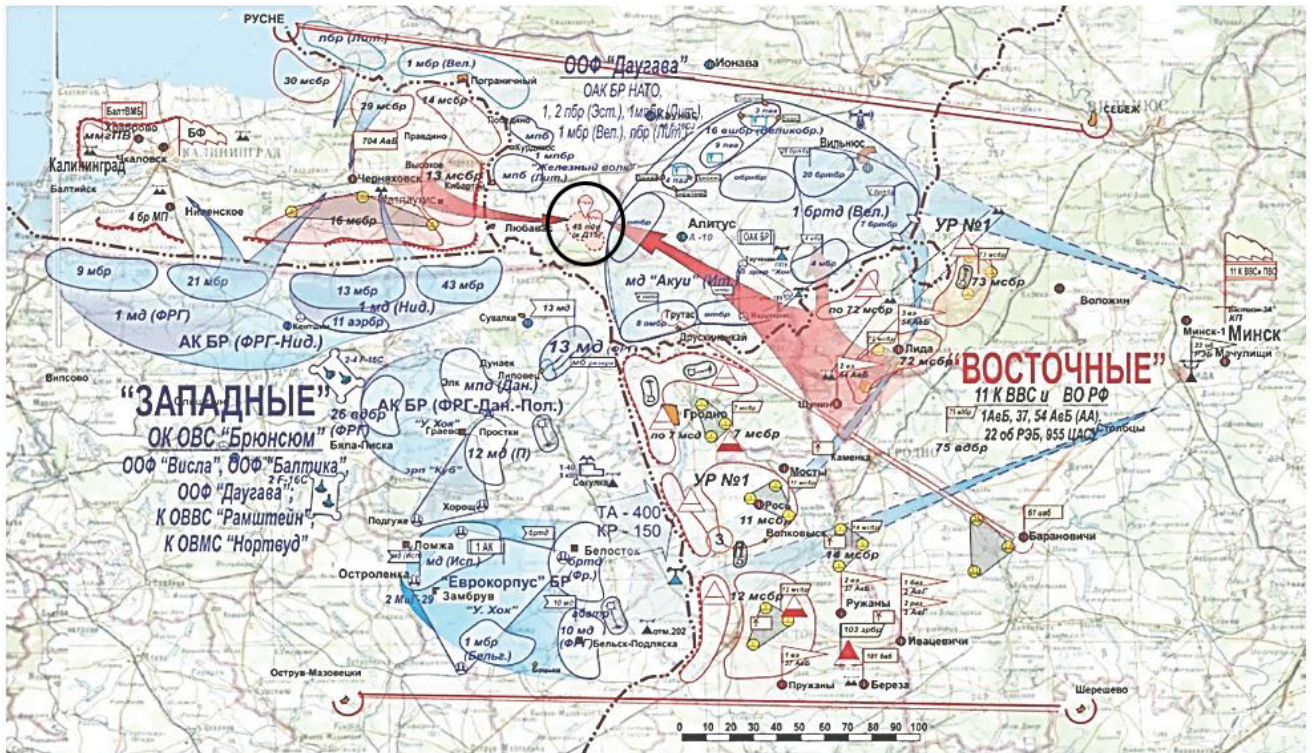

(Figure by V. V. Aristov et al. in "The Army Aviation Units Fire Missions Performance Effectiveness Estimating Methodology in the Dark Time of the Day Taking into Account Meteorological Conditions," *Aerospace Forces: Theory and Practice* [2019])

### Figure 3. The Close Operation with an Intermediate Objective

Similar to figure 2, the main effort of the close operation links Kaliningrad with Belarus and utilizes an airdrop operation in southern Lithuania (see circle).

produce destructive effects in a deep operation that could include some or all the NATO headquarters, key ports, airports, and other deployment sites if Russia feels threatened by a potential western military response. These capabilities are dual-capable, long-range, precision-guided ballistic and cruise missiles.

**Arranging operations.** Supporting (or enabling) operations will likely be blocking and interdiction effects to support the main effort. Also, the counterattack leaves open flanks toward Poland and Lithuania. A possible supporting operation is a flank cover that violates the territory of either of these two countries.

**Center of gravity.** From the perspective of Moscow, the center of gravity is most likely the slow decision-making process of NATO. If Article 5 is triggered, the General Staff will likely grab the initiative and seize key military objectives before the heads of state of NATO-nations reach an agreement on responding to Russian aggression.

When using some of these elements of operational design in combination with the disposition and tactical unit tasking, a clearer picture of the Russian concept of operations in the Baltic Sea region emerges (see figure 4, page 12).

### Russia's Desired End State

Now that we have a basic grasp of the intention of Zhuravlyov, we can infer Russia's desired end state and explain the scenario of an exercise like ZAPAD-2021 and why Moscow wants to reintegrate Kaliningrad.

The erosion of strategic depth worries the Russian political and military leadership. Since the end of the Cold War, its strategic depth has decreased significantly with the loss of key buffer states like Estonia, Latvia, and Lithuania. Militarily, this created several challenges for the General Staff.



(Figure by authors)

## Figure 4. Elements of the Russian Concept of Operations in the Baltic Sea Region

Of interest is the deep operation, which includes special operations to destroy critical infrastructure targets. To give an idea, four possible targets are Supreme Headquarters Allied Powers Europe, Allied Joint Force Command Brunssum, Aviano Airbase, and the port of Felixstowe.

First, from a Russian perspective, the encirclement of Kaliningrad by a military alliance (NATO) poses a great threat to the existence of a small piece of Russian sovereign territory. Kaliningrad is difficult to defend. As a mental exercise, imagine Vladivostok, a city in southeastern Russia, as American territory. That would create a complicated security dilemma for the United States.

Second, less strategic depth reduces military reaction time. Russian fears of a preemptive first strike, decapitating Moscow's political and military leadership and thereby disabling the Russian nuclear second-strike capability, sounds paranoid, but Russian history has taught leaders to fear invasion. Russia has suffered

numerous invasions, including the German invasion in World War II and Napoleon's invasion in 1812. This historical fear, paranoid or not, is culturally ingrained in the minds of Russian leaders. Figure 5 (on page 13) depicts this fear, where Russian military leadership speculates the United States will use sea and ground-launched Tomahawk cruise missiles against Moscow, decapitating political and military leadership.<sup>15</sup>

Last, military infrastructure creeping up to the Russian border increases NATO's operational reach. Some of the historical invasions just mentioned culminated due to insufficient operational reach. NATO's ability to use the Baltic region as a staging area is frightening



(Figure by Russian Ministry of Defense)

### Figure 5. Slide from a Briefing at the Moscow Conference on International Security in 2017

About one hundred countries gather annually at this conference to discuss the state of international security. Deputy commander of the Directorate of Operations of the General Staff Lieutenant-General Viktor Ploznikhir gave the briefing.

for Moscow. Russian leadership remembers all too well the utility of Operation Desert Shield. There are more military challenges to the General Staff than the three listed above, but these are especially problematic.

### Conclusion

This article aimed to take the first step toward designing the Russian concept of operations in the Baltic Sea region. First, we determined the disposition and the tasking of Russian military units during ZAPAD-2021. Second, using elements of operational art, we got a glimpse of the commander's intention of the Operational-Strategic Command West in Saint Petersburg. Last, we explored the reason behind the Russian concept of operations. In sum, Russia's historical utility of its depth, the reduction of reaction time to a preemptive military strike, and the encirclement of

Kaliningrad created challenges that the General Staff addressed. The Russians built a concept of operations that secures its sovereign territory and manages NATO's weakness: its slow decision-making process.

Using open-source data, especially real-time data often gathered by normal citizens in Russia and Belarus or local newspapers, this article emphasizes that intelligence gathering cannot simply end with gathering and interpreting the forces. Military intelligence analysts must work in conjunction with other members of an operational planning team to synthesize the relevant intelligence and form theories of the potential concept of operations that an adversary is using in their exercises.

The next step would be for planners to assess the strategic intentions behind the concept of operations. To accomplish this effectively, an operational planning

team must view the concept of operations from the adversary's social, political, cultural, and historical context. Is Russia practicing a potential future offensive operation? Is Russia showing force and capability simply to deter what it views as further aggression from NATO? Perhaps it is both simultaneously. These are the questions that must be asked.

## Recommendations

First, NATO's concept of operations should address the challenges posed by its Russian counterpart. To do this, it must focus on the weaknesses of Russian military power. For example, one can think of its lack of sustainment or potential difficulties in responding to NATO's opening of a second front.

Second, mitigating measures must be thought out to address the Russian deep operation. Moscow's

deep operation is important because it degrades decision-making and isolates Western Europe from the United States. Russia focuses on Western European critical infrastructure, airfields, ports, and headquarters such as SHAPE, using dual-capable precision-guided munitions. One way to mitigate this threat is to start thinking about fixed locations for air defense to protect these critical infrastructures, logistical, and headquarter nodes.

Third, we might look to alleviate the fears of the Russian leadership, which are rooted in history, culture, and rational observations about how close NATO nations now are to Moscow. De-escalatory attempts at reconciliation, like joint exercises, military exchanges, and diplomatic engagements might go a long way toward turning a tense situation into a far less threatening one for both Russia and NATO. ■

---

## Notes

1. Robin Emmott, "NATO Calls on Russia to Be Transparent with Military Exercises," Reuters, 3 September 2021, accessed 2 February 2022, <https://www.reuters.com/world/nato-calls-russia-be-transparent-with-military-exercises-2021-09-03/>.

2. "Пушков заявил об «истерии» Запада из-за Калининграда" [Pushkov announced the "hysteria" of the West because of Kaliningrad], RT, 23 March 2021, accessed 2 February 2022, <https://russian.rt.com/russia/news/845076-pushkov-isteriya-kaliningrad>.

3. Michael Kofman, "ZAPAD-2021: What to Expect from Russia's Strategic Military Exercise," War on the Rocks, 8 September 2021, accessed 2 February 2022, <https://warontherocks.com/2021/09/zapad-2021-what-to-expect-from-russias-strategic-military-exercise/>.

4. Robert Dalsjö, Christofer Berglund, and Michael Jonsson, *Bursting the Bubble: Russian A2/AD in the Baltic Sea Region: Capabilities, Countermeasures, and Implications* (Stockholm: Swedish Defence Research Agency, March 2019), accessed 2 February 2022, <https://muep.mau.se/handle/2043/30208>; Lyle J. Morris et al., *Gaining Competitive Advantage in the Gray Zone* (Santa Monica, CA: RAND Corporation, 2019), accessed 2 February 2022, [https://www.rand.org/pubs/research\\_reports/RR2942.html](https://www.rand.org/pubs/research_reports/RR2942.html); Ofer Fridman, "On the 'Gerasimov Doctrine: 'Why the West Fails to Beat Russia to the Punch,'" *Prism* 8, no. 2 (October 2019): 101–12, accessed 2 February 2022, [https://ndupress.ndu.edu/Portals/68/Documents/prism/prism\\_8-2/PRISM\\_8-2\\_Fridman.pdf?ver=2019-09-17-231059-263](https://ndupress.ndu.edu/Portals/68/Documents/prism/prism_8-2/PRISM_8-2_Fridman.pdf?ver=2019-09-17-231059-263).

5. North Atlantic Treaty art. 5, 4 April 1949, 63 Stat. 2241, 34 U.N.T.S. 243.

6. Joint Publication 5-0, *Joint Planning* (Washington, DC: U.S. Government Publishing Office, 1 December 2020), GL-6, accessed 2 February 2022, [https://www.jcs.mil/Portals/36/Documents/Doctrine/pubs/jp5\\_0.pdf](https://www.jcs.mil/Portals/36/Documents/Doctrine/pubs/jp5_0.pdf).

7. "Початок маневрів 'Запад-2021' та перекидання російських винищувачів Су-30СМ у Білорусь" [Beginning

of "West 2021" maneuvers and transfer of Russian Su-30SM fighters to Belarus], Information Napalm, 10 September 2021, accessed 2 February 2022, <https://informnapalm.org/ua/zapad-2021-pochatok/>.

8. Bob Ashley and Neil Wieli, "How the Intelligence Community Can Get Better at Open Source Intel," Defense One, 16 July 2021, accessed 2 February 2022, <https://www.defenseone.com/ideas/2021/07/intelligence-community-open-source/183789/>.

9. "Западный форпост готовится к учениям «Запад-2021»" [The Western outpost is preparing for the exercises "West-2021"], VPK News, 4 September 2021, accessed 2 February 2022, <https://vpk-news.ru/news/63685>; "Початок маневрів 'Запад-2021'" [Beginning of "West 2021"]; "Zapad-2021 Strategic-Operational Exercise-ORBAT," *Rochan Consulting* (blog), 2 August 2021, accessed 2 February 2022, <https://rochan-consulting.com/zapad-2021-strategic-operational-exercise-orbat/>; "Экипажи самолетов ВКС и авиации ЗВО отработали нанесение массированного бомбового удара на авиационном полигоне под Смоленском в рамках учения 'Запад-2021'" [The crews of the aircraft of the Aerospace Forces and aviation of the Western Military District worked out the application of a massive bombing strike at an aviation training ground near Smolensk as part of the exercise "West-2021"], *Aviation Explorer*, 13 September 2021, accessed 2 February 2022, <https://www.aex.ru/news/2021/9/13/234959/>; "Three Pairs of Tu-22M3 Long-Range Bombers Dropped 1.5-Ton Bombs on the Control Posts of a Mock Enemy at the Mulino Training Ground," Russian Ministry of Defense, accessed 23 February 2022, [https://function.mil.ru/news\\_page/country/more.htm?id=12383925@egNews](https://function.mil.ru/news_page/country/more.htm?id=12383925@egNews); "Zapad-2021 Strategic-Operational Exercise-Part 3 (First Deployments into Belarus)," *Rochan Consulting* (blog), 26 July 2021, accessed 2 February 2022, <https://rochan-consulting.com/zapad-2021-strategic-operational-exercise-part-3/>; "Watch Russian Airborne Troops Make Nighttime Assault Landing at Russian-Belarusian War Games,"



RT, 12 September 2021, accessed 2 February 2022, <https://www.rt.com/russia/534639-airborne-troops-nighttime-assault-drills/>; "Zapad 2021 – Day 4 (September 13)," Russian Military Analysis, accessed 23 February 2022, <https://russianmilitaryanalysis.wordpress.com/2021/09/16/zapad-2021-day-4-september-13/>; "Zapad 2021 – Day 3 (September 12)," Russian Military Analysis, accessed 23 February 2022, <https://russianmilitaryanalysis.wordpress.com/2021/09/14/zapad-2021-day-3-september-12/>; "Zapad 2021 – Day 2 (September 11)," Russian Military Analysis, accessed 23 February 2022, <https://russianmilitaryanalysis.wordpress.com/2021/09/13/zapad-2021-day-2-september-11/>.

10. Alexander Svechin, *Strategy* (Minneapolis: East View Publications, 1992).

11. Timothy L. Thomas, *Russian Military Thought: Concepts and Elements* (McLean, VA: The MITRE Corporation, August 2019), accessed 2 February 2022, <https://www.mitre.org/sites/default/files/publications/pr-19-1004-russian-military-thought-concepts-elements.pdf>.

12. "Республика Полесье и Центральная Федерация будут обороняться от 'Западных' и террористов: как пройдет учение 'Запад-2021'" [The Republic of Polesie and the Central Federation will defend themselves from the "Western" and terrorists: how will the exercise "West-2021"], СМАПТНПЕСС [Smartpress], 9 September 2021, accessed 2 February 2022, <https://smartpress.by/news/12352/>.

13. "Russia's Grom–2019 Strategic Nuclear Exercise," *Strategic Comments* 25, no. 9 (December 2019): vii–ix, accessed 2 February 2022, <https://www.iiss.org/publications/strategic-comments/2019/russias-grom2019-strategic-nuclear-exercise>.

14. V. V. Aristov et al., "The Army Aviation Units Fire Missions Performance Effectiveness Estimating Methodology in the Dark Time of the Day Taking into Account Meteorological Conditions," *Aerospace Forces: Theory and Practice* 12 (2019): 15, <https://vva.mil.ru/upload/site21/Qnbzgbjfnypdf>.

15. "Russian Deputy Minister of Defence Colonel General Alexander Fomin Summarising IX Moscow Conference on International Security," Russian Ministry of Defense, accessed 23 February 2022, <https://eng.mil.ru/en/mcis/news/more.htm?id=12368474@egNews>.



# Military Review

## BOOK REVIEW PROGRAM

The *Military Review* book review program allows reviewers to read books of interest to military professionals—often before book publication—and then present their thoughts on the Army University Press website. The reviewer then retains the book. Read our latest book reviews at <https://www.armyupress.army.mil/Journals/Military-Review/MR-Book-Reviews/>.

Books for review are available only through the *Military Review* book review editor. If you are interested in becoming a reviewer, see our Book Review Submission Guide at <https://www.armyupress.army.mil/Journals/Military-Review/MR-Book-Review-Submission-Guide/>.

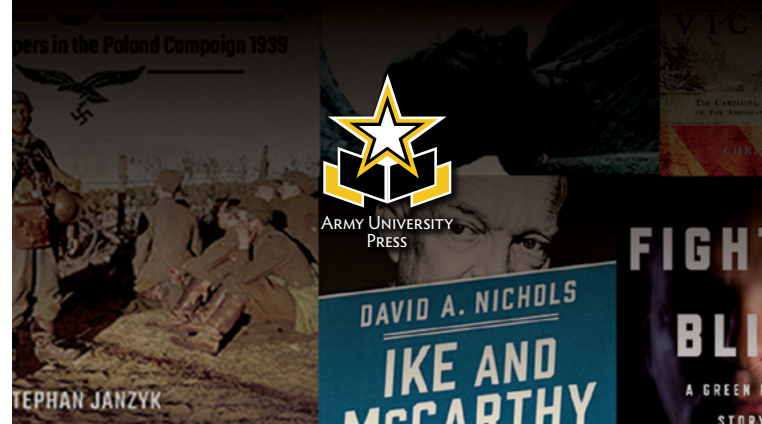



German soldiers from the Rapid Response Forces Division move toward simulated enemy forces during NATO exercise Green Griffin 21 on 4 October 2021 at Lehnin, Germany. Green Griffin is an annual NATO training exercise designed to increase the scale, capability, and interoperability of NATO allies and partner forces. The exercise involved elements from the U.S. Army's 12th Combat Aviation Brigade, the Bundeswehr's Rapid Response Forces Division, the Netherlands air force, and the Romanian army's Mechanized Brigade. (Photo by Michele Wiencek, U.S. Army)

# Multi-Domain Warfighting in NATO

## The 1 German-Netherlands Corps View

Lt. Gen. Andreas Marlow, German Army

Lt. Col. Wilson C. Blythe Jr., U.S. Army

Since its formation in 1995 as a result of the merger of the Cold War-era 1 German Corps and 1 Dutch Corps, 1 German-Netherlands (GE/NL) Corps has repeatedly confirmed the commitment of its framework nations (Germany and Netherlands) to NATO, deploying to Afghanistan in 2003, 2009, and 2013. To continue this commitment, deter aggression, and defend the Euro-Atlantic area, 1 (GE/NL) Corps must demonstrate the ability to conduct large-scale combat operations as part of NATO against a peer enemy in an Article 5 scenario. The ability to conduct large-scale combat operations underpins the credibility of the Alliance's deterrence and provides the basis for the defense of the Euro-Atlantic area in the event of conflict. This means that 1 (GE/NL) Corps must possess the ability to successfully perform the warfighting corps role, following its 2023 stand-by period as the NATO Response Force (NRF) Land Component Command (LCC).<sup>1</sup>

Execution of the warfighting corps role on the Euro-Atlantic multi-domain battlefields of today and tomorrow requires specific capabilities, in the required capacities, along with the expertise necessary to employ them in an Article 5 scenario against a peer enemy. As part of its transformation into a warfighting corps capable of multi-domain operations (MDO), 1 (GE/NL) Corps has conducted a campaign of learning consisting of academics, wargaming, and training and exercises. The results of this work are detailed below and specify the roles and responsibilities of a NATO warfighting corps within MDO, define the requirements and the structure for an MDO-capable warfighting corps, and describe the conduct of corps operations within the context of an Article 5 scenario.<sup>2</sup>

## Organization

In contrast to stabilization operations in which the corps acted as a command-and-control node, for warfighting operations the corps functions not only as a headquarters but also as a formation that consists of its headquarters, combat and maneuver support forces, sustainment units, and other functional support units assigned to, attached to, or under the operational control of the corps.<sup>3</sup> Also included are functional support capabilities operating in direct support of the corps or its subordinate divisions. Functional support units operating in the corps area of operations as general

support, but not part of the corps, are normally not included in the corps formation.

When operating in the context of an Article 5 or warfighting operation, the corps is the highest tactical echelon. It is task organized for the operation, taking into account the operational and mission variables, and that task organization is dependent on the relative combat power of the enemy formations with which the corps will be engaged, the mission it receives, and the size of the area of operations in which it will operate. There are several proposed corps structures for the MDO battlefields of today and tomorrow. While there is much overlap to these proposals, the 1 (GE/NL) Corps structure was specifically developed to focus on the threats to the Euro-Atlantic area (see figure 1, page 18).<sup>4</sup>

Ideally, a NATO corps capable of conducting multi-domain operations within the Euro-Atlantic area includes the following:

- ◆ 2 to 5 divisions
- ◆ 1 x military intelligence brigade
- ◆ 1 x intelligence, surveillance, and reconnaissance (ISR) battalion equipped with unmanned aircraft systems (UAS) and unattended ground sensors (UGS)
- ◆ 1 x electronic warfare battalion
- ◆ 1 x corps fires command
- ◆ 2 x long-range artillery brigades
- ◆ 1 x cyber company
- ◆ 1 x ISR/targeting battery equipped with UASs and UGSs
- ◆ 1 x aviation brigade
- ◆ 1 x armored reconnaissance and surveillance brigade
- ◆ 1 x information warfare battalion
- ◆ 1 x psyops company
- ◆ 1 x engineer brigade (including chemical, biological, radiological, and nuclear [CBRN] capacity)
- ◆ 1 x air defense brigade
- ◆ 1 x signal brigade with a dedicated cyber defense organization
- ◆ 1 x rear area operations command
- ◆ 1 x sustainment brigade
- ◆ 1 x medical brigade
- ◆ 1 x military police brigade
- ◆ 1 x CBRN defense battalion
- ◆ 1 x civil affairs battalion with a political liaison team

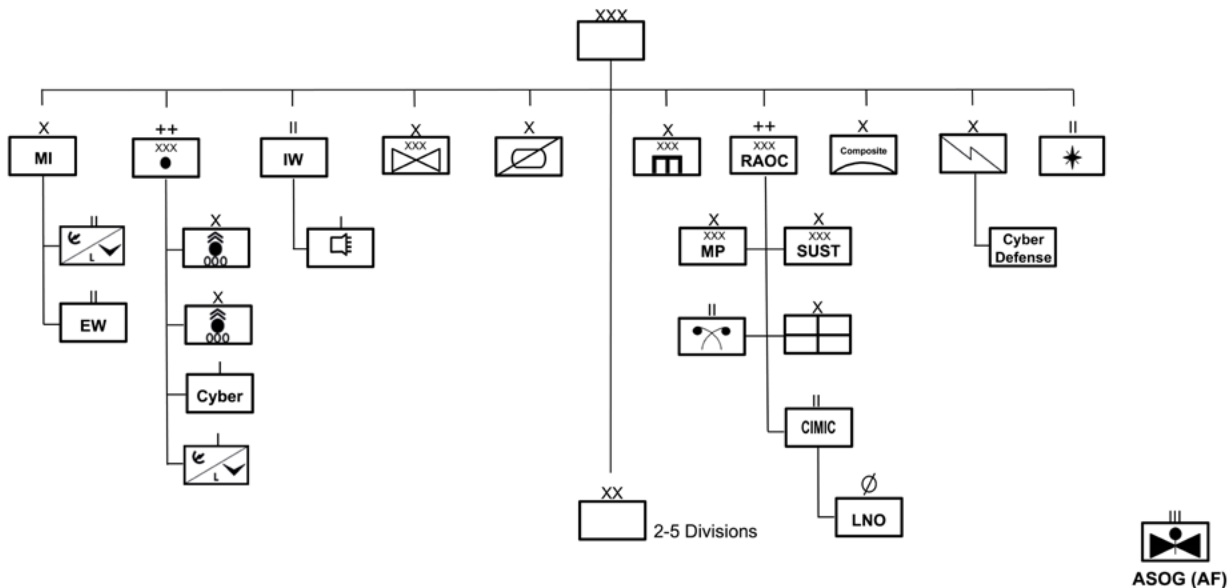

Note: Space Battalion includes high altitude companies for use as ISR or signal platforms

(Figure by Cpls. S. de Vries and N. Noordermeer, 1 [GE/NL] Corps REPRO Office)

### Figure 1. 1 (GE/NL) Corps Structure

- 1 x space battalion (includes high-altitude companies for use as ISR or signal platforms)
- Other forces may be assigned, attached, or provided operational control to give the corps additional capabilities) or additional capacity.<sup>5</sup>

Much of the structure above may sound familiar. However, based upon analysis conducted by 1 (GE/NL) Corps, this structure is better optimized to penetrate and dis-integrate the integrated air defense systems (IADS) and the integrated fires complex (IFC) that could challenge NATO forces in the Euro-Atlantic area. The presence of substantial long-range fires systems provides the corps with an organic capability to engage enemy fires systems and support assigned forces or other component commanders if conflict should occur. The corps’s capability to link a greater number of sensors than in the past, located throughout the depth of an expanded battlefield, to specific shooters enables it to converge capabilities in support of operational objectives and enhances the deterrent effect of Alliance ground forces.<sup>6</sup>

A key formation within the corps is the corps fires command, which integrates joint, interorganizational,

and multinational targeting capabilities. The corps fires command plans, coordinates, and delivers joint all-domain fires to shape operations. The scale and scope of operations against a peer enemy generally necessitates multiple brigades of long-range rockets and missile systems. Two assigned field artillery brigades provide the corps with the means to defeat an enemy’s long-range and midrange fires and IADS to enable divisional tactical operations and freedom of maneuver for the Alliance joint force.<sup>7</sup>

Unlike a U.S. Army corps, a NATO corps does not fall under a standing theater army with organic capabilities or have subordinate divisions with a common and standardized divisional structure. Depending on the composition of the corps’s higher echelon and subordinate divisions and brigades, the corps may require additional capabilities or capacity. These capability gaps are most likely to be found in electronic warfare (EW), fires, ISR, and intelligence. During Article 5 operations, divisions will require additional assets to assist in converging effects from multiple domains. While the corps does not own space or special operations assets and its

organic cyberspace capabilities are limited, it does possess the necessary tie-ins and expertise to integrate these domains into its operations. As the critical echelon in the execution of MDO, the corps will need the capacity to provide concurrent support to multiple divisions.<sup>8</sup>

## Role of the Corps

1 (GE/NL) Corps is a multinational headquarters assigned to NATO. Therefore, NATO-compatible equipment (e.g., communication and information systems), and NATO processes and procedures (e.g., the operations planning process; data management platforms; and Allied Procedural Publication 28, *Tactical Planning for Land Forces*) will be used. It can translate operational inputs into tactical outputs. It synchronizes maneuver, fires, and effects with the requisite maneuver support and sustainment to shape the environment for subordinate forces to accomplish tactical missions and achieve operational and strategic objectives. This is accomplished through planning and mission orders to subordinate forces, making the best use of their capabilities and capacities while enforcing unity of command and achieving unity of effort.

To defeat the enemy, the corps executes five functions. It

- ◆ shapes the enemy forces in the corps deep area with available corps and joint capabilities;
- ◆ maneuvers divisions and other combat formations to gain positions of advantage to close with and defeat enemy forces and compel their surrender or withdrawal, synchronizing the maneuver of divisions and, if necessary, brigades to reduce friction and coordinating the simultaneous maneuver of multiple formations in time and space;
- ◆ initiates, executes, implements, ensures, and supports consolidation activities to set conditions for transition to a sustainable political end state;
- ◆ sustains close, deep, and consolidation operations; and
- ◆ generates combat power through reception, staging, onward movement, and integration; and reconstitution.

The corps sets the conditions for subordinate divisions to focus on the close fight by integrating all elements of combat power in time and space to disrupt, interdict, and degrade the enemy while shaping the operating environment and enabling friendly forces to ensure freedom of action at the expense of its opponent. While the corps leverages Alliance joint capabilities to

achieve effects in its area of operations, it is fundamentally a tactical and land-centric formation.<sup>9</sup>

In the conduct of its operations, it is essential that the corps sets an operational tempo that does not permit the enemy to recover and establishes an inexorable momentum using echeloned maneuver to ensure that once contact is gained, it is maintained. The corps feeds forces into the main battle area and controls the dispersion and mass of maneuver units. Divisions do the same at their level. The corps enables operational tempo at the division level by keeping enemy space, cyber, air defense, and long-range and midrange fires under constant pressure. This allows the divisions to finish decisively once they gain contact with the enemy. Momentum and tempo are vital and are metrics the corps commander uses to gauge success.<sup>10</sup>

Momentum and tempo are the threads that run through the corps's operations and ensure that the enemy faces a continuous onslaught of simultaneous multi-echelon convergence.

**Lt. Gen. Andreas Marlow, German Army**, is the commander of the NATO Rapid Deployment Headquarters, 1 German-Netherlands Corps. He has commanded at every level in the German Army. Marlow deployed as the Chief of Staff of the German contingent within NATO's Kosovo Force mission, Deputy Chief of Staff-Operations Regional Command North International Security Assistance Force, and as the Chief of Staff Headquarters Resolute Support in Afghanistan. He is a graduate of the University of the Bundeswehr Hamburg, the German General Staff Officers Course, and the Command and Staff Course at the Canadian Forces College.

The importance of controlling the pace of operations challenges command and control because the corps must maintain forces not in contact to ensure fresh forces can reinforce success. The side that sets an overwhelming tempo

**Lt. Col. Wilson C. Blythe Jr., U.S. Army**, is a strategist in the G-5 Plans of the 1 German-Netherlands Corps. He holds a bachelor's degree in history from the University of Mississippi and a master's degree in history from Eastern Michigan University. Blythe is a recipient of the Army Historical Foundation's Distinguished Writing Award. His service includes deployments to Iraq and Afghanistan.



German and Dutch soldiers coordinating their route during NATO exercise Green Griffin 2021 in Lehnin, Germany. (Photo courtesy of 1 [GE/NL] Corps Public Affairs Office)

will win. However, the speed component of tempo is not just speed of decision but also the cumulative speed of all our actions from planning and issuing orders to executing movements, fire missions, and transmitting decisions.<sup>11</sup>

Given the nature of the threats posed to the Euro-Atlantic area, an MDO-capable NATO corps must maintain joint, interservice, and multinational relationships to facilitate the quick transition to conflict. These relationships help prepare the corps for its role as the senior land tactical headquarters and are developed and maintained through multi- and bilateral training events and exchanges as well as the multinational layout of the headquarters itself. 1 (GE/NL) Corps emphasizes and trains the comprehensive approach in all phases of competition, conflict, and postconflict.<sup>12</sup>

The presence of a corps and its subordinate units serves as a deterrent force capable of simultaneously engaging multiple enemy combined arms armies and provides the means to shape the area of responsibility. During competition, the conduct of intelligence activities

to set the conditions for successful combat operations will be a major focus of the corps. This work is essential to establishing the preconditions not only for a rapid transition to conflict but also for the achievement of tactical objectives. This includes the conduct of the threat systems analysis and comprehensive understanding of the operational environment (CUOE) necessary to support the convergence of Alliance, national, and organic assets necessary to achieve the desired effects against the enemy's sophisticated and resilient layered standoff.<sup>13</sup>

The corps denies/deters the ability of an enemy's ISR and EW systems to target NATO formations and facilities to gather information about capabilities. In addition, as deception is a key function of the corps, it will focus on deceiving and denying an adversary's access to information related to current and future operating locations, units, and equipment.

To achieve decisive effects on an enemy during combat operations, the corps synchronizes and integrates combat power throughout the expanded battlefield. The

ability of the corps to shape the lower operational and upper tactical environments is especially vital to Alliance operations during the initial period of a conflict when enemy long-range IADS will deny, or at a minimum contest, the Alliance's use of the air domain. The contribution of the corps to the penetration and dis-integration of the enemy's layered standoff is essential to generating freedom of maneuver for the Alliance joint force.<sup>14</sup>

During Article 5 or warfighting operations, the focus of the corps is on the conduct of the fight in the deep area with the objective of collapsing the enemy's long-range and midrange IFC and IADS. The MDO-capable NATO corps utilizes an array of interconnected sensors—artillery delivered, UAS, cyberspace, space, and infiltrated—that place enemy systems at risk. These allow the corps to employ its long-range artillery to destroy targets throughout the depth of the corps area of operations. It is important to remember that this is not a targeting drill; these mid- and long-range enemy systems are attacked to enable maneuver and freedom of action. Only by defeating the enemy's layered standoff will the Alliance be able to apply its air assets and will the corps's subordinate divisions get to the close fight with the combat power to prevail.<sup>15</sup>

The corps is the central echelon in the planning and execution of MDO and is the lowest echelon capable of converging all domains. It creates the conditions for convergence at lower echelons by allocating resources, sequencing division maneuver, and incorporating it with deception. Especially within NATO, the corps will be the primary integrator and synchronizer of multi-domain capability in the forward conflict area and will array assigned capabilities to defeat enemy systems and enable tactical maneuver.

Much as it does with the air and maritime domains, the corps coordinates for—it does not execute—and integrates effects from the space and cyberspace domains through space and cyber support teams embedded in the command. These include effects to disrupt satellite communications to compound effects by organic EW against key command-and-control nodes to degrade enemy positioning, navigation, and timing, cyberspace and space-based ISR, and offensive cyberspace operations. Though the corps may not have the organic capabilities in all domains, it must possess the ability—to include the necessary staff bandwidth and expertise—to access effects from the space, cyberspace, and other domains.

By synchronizing all reconnaissance and security operations across subordinate units, coordinating intelligence requirements, and fusing intelligence from multiple echelons, the corps supports echeloned maneuver and actively informs and integrates the full range of capabilities in all domains throughout the depth of the battlefield. Additionally, the corps unburdens subordinate formations by narrowing their focus, reducing their span of control, and maintaining the broader perspective in time and space, across the expanded battlefield. The planning horizon of a corps is typically seventy-two to ninety-six plus hours.<sup>16</sup>

While the corps's focus is on the deep area, and much has evolved with MDO, the corps still supports division-level tactical maneuver. In the close fight, it will support its major subordinate units by reinforcing them with forces, especially in the main effort (*Schwerpunkt*) and by applying joint effects, fire support, air and missile defense, and to a limited extent, cyber defense. The corps will have to conduct information activities and additional stability tasks as well. The ability of the corps to provide this support to its subordinate divisions is especially critical in a multinational setting where the structure and capabilities of its subordinate divisions can greatly vary.<sup>17</sup>

To preserve the corps's freedom of action for operations in the deep and close areas and to extend the force's operational reach, in part through the generation or reconstitution of combat power, the corps must provide security in the rear area to prevent or minimize disruption of combat support and combat service support from the rear area forward and provide unimpeded movement of friendly forces throughout the rear area. To do this, the corps must be able to find, fix, and defeat enemy incursions into the rear area. This will require close coordination with host-nation defense and security forces, and nonmilitary actors.<sup>18</sup>

The corps must wage this fight to protect its formations in the rear and close areas while simultaneously waging a fight in the deep area to set conditions for exploitation, and it must manage forces out of contact to ensure exploitation can be sustained and reinforced. The corps must provide for the echelonment of formations to ensure depth and agility to maintain tempo once a penetration occurs.<sup>19</sup>

The corps protects its subordinate tactical formations from attacks originating in other domains. Especially

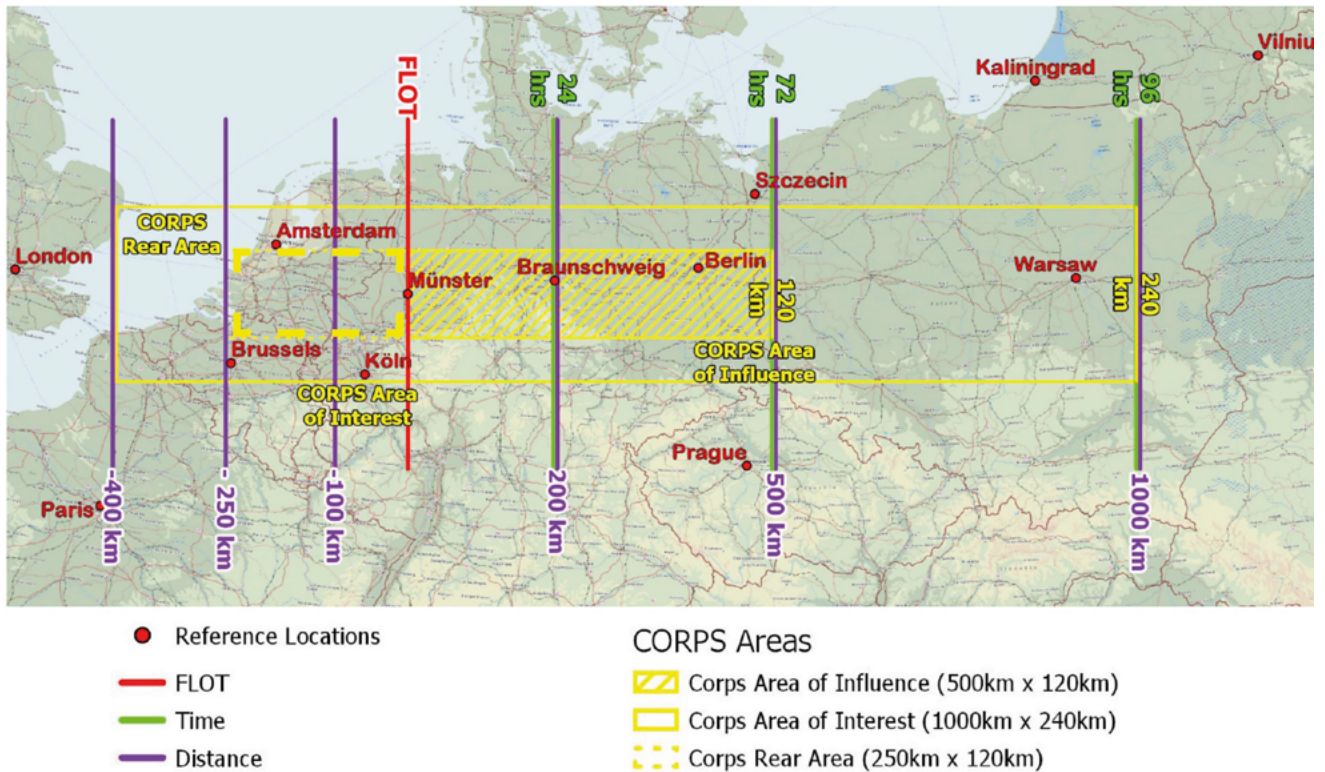

(Note: Lines are illustrative and not adapted to the terrain. Figure by Oberstabsfeldwebel Björn Ehlenberger, GIS NCO, 1 [GE/NL] Corps)

**Figure 2. Corps Battlefield Geometry**

important is the requirement to provide air and missile defense against the enemy’s substantial inventory of artillery and ground- and air-launched missiles. This will enable the divisions to engage in the close fight with favorable combat power ratios. To do this, the corps must not only possess the necessary air and missile defense assets but also incorporate deception and electromagnetic spectrum management into its operations. The main effort will be on proactive counterfire.<sup>20</sup>

To succeed, the corps must set the conditions prior to conflict (i.e., in competition). Especially important is the continuous conduct and refinement of the robust CUOE of the enemy required to understand its key systems so the corps can begin the penetration and dis-integration of the enemy’s mid- and long-range IADS and IFC during the transition to conflict. Vital to the success of these efforts is the corps’s ability to exercise command and control throughout the depth of the expanded battlefield. To command and control throughout the entirety of its area of operations, the corps will employ

a distributive command post structure using multiple, dispersed, and mobile command posts.<sup>21</sup>

The corps area of operations and responsibility can extend up to 500 km deep and includes multiple echelons of tactical- and operational-level adversarial capabilities. Figure 2 illustrates how a corps operates across more than 60,000 km<sup>2</sup> during large-scale combat operations. Assuming the corps consists of two divisions abreast, the area of operations for the corps could be 500 km x 120 km. In consequence, the corps area of influence would extend out 500 km/72 hrs., while the corps area of interest would extend out to 1,000 km/96 hrs.<sup>22</sup> In this example, the corps rear area extends 200 to 250 km to the rear of the forward line of own troops.<sup>23</sup>

## How the Corps Fights

**Corps during competition.** During competition, the corps focuses on preparing to conduct operations in its potential area of operations. This entails rigorous



planning to enable it to rapidly deploy to its area of operations and defeat possible enemy military forces in combat operations. This planning is based on a rigorous and continuous CUOE that results in the necessary appreciation of the terrain, information environment, and understanding of likely enemy actions and capabilities to the systems level. This CUOE informs not only the corps but also its subordinate formations. Because of the increased complexity and resiliency of enemy systems, this work during competition is a prerequisite for successful operations during conflict.<sup>24</sup>

One of the corps's missions in competition is to enhance the conventional deterrence capabilities of NATO through its demonstrated proficiency in executing MDO. During competition, the corps trains to achieve the necessary expertise in MDO so that it can defeat equivalent enemy combined arms formations. The corps must regularly exercise the employment of capabilities from not only the air and maritime domains but also the space and cyberspace domains to stimulate, see, and strike enemy capabilities—especially long- and mid-range IFC and IADS.

Through the conduct of cooperative engagements, participation in multinational training exercises, and military-to-military partnerships, the corps can develop relationships with other Alliance forces and the interagency, enhancing the capabilities and interoperability—both conceptual and technical—of all involved. These exercises also allow the corps to practice sustaining itself and work out the details needed to deploy, sustain, and reconstitute a combat-ready force. In addition, exercising sustainment of the corps helps to build relationships with host nations and other entities that will be invaluable in the event of conflict. Developing the corps's ability to conduct MDO is critical to interoperability with U.S. formations and therefore to the Alliance's ability to deter aggression and support NATO information operations.<sup>25</sup>

The routine deployment of the corps and subordinate formations to conduct training and exercises makes their deployment during times of tension less complicated and escalatory. As tensions rise, forward-presence corps forces can rapidly reposition to dispersed locations and conduct multi-domain deception operations to complicate enemy targeting and decision-making activities. The creation of multiple, to include false, pictures in the electromagnetic spectrum aids in deceiving the enemy.

It slows down his ability to identify and target friendly formations and command posts. The complexities of planning for deception at the scale required do not reside in any echelon lower than the corps.

The corps and its subordinate formations must be capable of rapid deployment, transition to combat operations, and fighting a very intense battle on short notice. The corps will most likely not be allowed to conduct an uncontested deployment and build-up of combat power. Instead, it will be contested as it maneuvers from its peacetime location to its assigned area of operations where the corps will likely proceed directly into contact. This initial battle will be part of a campaign because modern militaries are too resilient to be defeated in a single battle. Success in this initial battle is vital to setting conditions for the rest of the campaign and posturing NATO for a favorable conclusion to the conflict.<sup>26</sup>

#### **Corps during penetration and dis-integration.**

Even prior to the initiation of open hostilities, NATO forces will likely be operating inside the umbrella of a peer enemy's IADS and IFC. With the beginning of open conflict, their IADS and IFC will impede key elements of the joint force so that they will not be able to support Alliance ground operations, or at least will have their operations severely degraded. Instead, Alliance land forces must conduct operations in support of forces of other domains so that the full weight of the Alliance's capabilities can be brought to bear on the enemy.

In practice, this will mean that at the onset of operations, the corps can expect limited support from the air and maritime domains. The campaign against an enemy's long- and mid-range systems will likely be waged primarily by land-based fires. Unlike during the Cold War, when such a capability resided in NATO's field armies, today's operational echelon is absent such a capability, which means that the corps with its corps fires command will be responsible for enabling the freedom of action for the Alliance's joint force.

Although on the move, the corps fires command provides on-order support to augment the operational echelon's operations to destroy high-value targets and degrade enemy long-range fires and air defenses. As soon as the enemy's IADS is dis-integrated, NATO can employ greater quantities of fifth-generation aircraft until these enemy systems are eventually collapsed and fourth-generation aircraft can be unleashed against

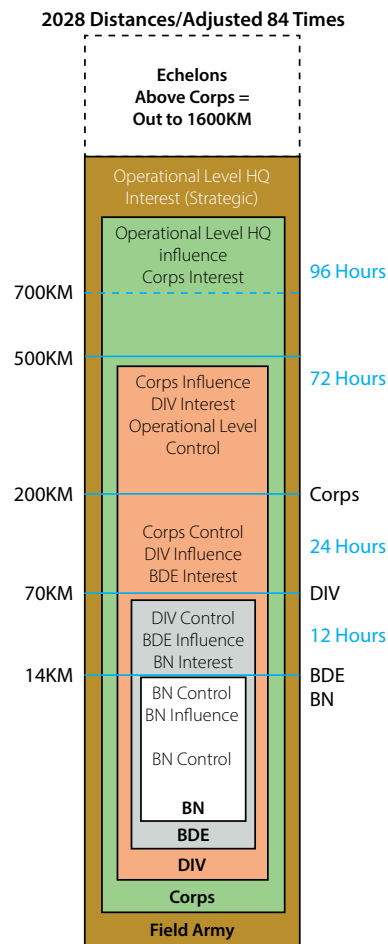
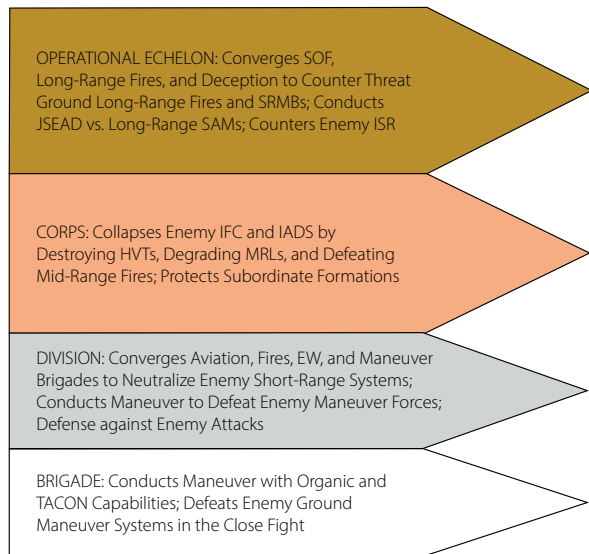

(Figure by Cpls. S. de Vries and N. Noordermeer, 1 [GE/NL] Corps REPRO Office)

### Figure 3. Fighting by Echelon

enemy ground forces. As the weight of air assets that NATO is allowed to commit against enemy ground forces increases, the corps fires command can shift the priority of its fire support assets to defeat the enemy’s mid-range fires systems and to support its maneuvering divisions (see figure 3).

In addition, the corps maneuvers to seize objectives and defeat enemy forces. The corps will employ a covering force to attrit enemy maneuver forces and gain intelligence about the strength and direction of potential attacks. Just as importantly, this covering force will compel the enemy to deploy his forces and mount an attack. This will slow the rate of the enemy’s advance, thus gaining time for the corps to bring additional combat power into the fight and for NATO’s campaign against the enemy’s IADS to create windows of opportunity for the employment of air and maritime assets.

The ability to conduct multiple wet-gap crossings will be critical to the success of the corps. It is estimated that land forces operating in eastern or central Europe will have to conduct a wet-gap crossing of a small (six-meter wide) water obstacle every twenty kilometers, a medium size (one hundred-meter wide) river every thirty-five to sixty kilometers, and a large river (one hundred to three hundred meters wide) every 100 to 150 kilometers. The ability to conduct a succession of these wet-gap crossings is essential to the corps’s ability to maintain the necessary momentum.<sup>27</sup>

As the corps maneuvers, likely from

its peacetime locations toward its area of operations to assume control of the tactical-level fight, it is liable to commit forces to the fight as they become available in order deny enemy military objectives or at a minimum extend the timeline it takes enemy forces to seize them, thus allowing NATO to commit more combat power to the fight. Under these chaotic conditions, habitual, or preferably formalized and permanent, relationships will be critical to the corps performance and cohesion.<sup>28</sup>

With limited forces initially available, the corps is responsible for preserving its combat power to enable success in close combat operations by conducting survivability, multi-domain deception, and obsuration operations. It is responsible for the protection of subordinate formations as well as forward-deployed divisions as they maneuver to close with enemy forces. Additionally, the corps prepares to receive additional

forces as they deploy to the area of operations.

In contrast to the linear forward deployment of NATO corps during the Cold War, today's NATO corps must be prepared to conduct noncontiguous defense spread out from front to rear over many kilometers. Given the ratio between space and forces available, there cannot be anything approaching a continuous line of defense as this would be too brittle. The corps will use complex terrain as strongpoints to bolster the resiliency

of its defense. This defensive battle will require a great deal of offensive action with opportunistic counterattacks to defeat exposed enemy forces and dislocate an enemy offensive.<sup>29</sup>

Throughout the fight, the corps must extract sufficient forces from the fight to form a reserve large enough to influence events; this applies to both when the corps is attacking and defending. Forming a reserve will be especially difficult in the initial phase of the battle when the disparity of forces will be at their greatest, but the more difficult it is, the more necessary it will be. The corps must balance denying an enemy from achieving its military objectives with the need to preserve sufficient combat power.<sup>30</sup>

Success by the corps and its subordinate formations or setbacks or failures by the enemy, and contradictions between words and deeds will be highlighted by information operations at the corps and higher echelons. To be relevant and effective, information operations must always be tied to the physical domains. The success of information operations, especially that rooted in "propaganda of the deed," will be a critical component of securing battlefield gains.<sup>31</sup>



A Dutch soldier from the Rapid Response Forces Division scans the area during a scouting mission as part of the NATO exercise Green Griffin 21 on 4 October 2021 at Lehnin, Germany. Green Griffin is an annual NATO training exercise designed to increase the scale, capability, and interoperability of NATO allies and partner forces. The exercise involved elements from the U.S. Army's 12th Combat Aviation Brigade, the Bundeswehr's Rapid Response Forces Division, the Netherlands Air Force, and the Romanian Army's Mechanized Brigade. (Photo by Michele Wiencek, U.S. Army)

**Corps during exploitation.** The corps is the senior NATO headquarters level responsible for directing the tactical fight. It will converge the capabilities of its operational and subordinate divisional fires assets with space, cyber, and special operations assets along with air assets to stimulate, see, strike, and assess targets in the close combat area. The neutralization of an enemy's first and second echelon mid-range fires systems will allow the corps's divisions to isolate and defeat the leading elements of the attacking enemy's first echelon. With the defeat of these forces, the corps can exploit the successes with its available divisions.

The corps's aviation brigade will perform multiple roles. The attack assets will be available to execute deep strikes and to perform area of operations-wide security tasks. Because of the abundance of a peer enemy's air defense systems, deep strikes by attack aviation will most likely be conducted at night with smaller groups of aircraft using terrain masking for protection as they approach their objective. It is unlikely that these attacks will be conducted to the full depth of the corps area of influence—those will most likely be conducted with long-range or joint fires. Use of lift assets will support

sustainment operations throughout the area of operations. Intelligence assets in conjunction with signal assets will cross-cue with corps fires command and/or corps aviation brigade UAS to provide targetable data via the integrated fires network for strikes by the corps fires command. Organic or attached intelligence assets will utilize employed sensors to see and track displacing enemy's elements to enable follow-on engagement.

The corps's responsibility for protection of the Alliance's tactical formations continues to be crucial to the success of operations. To follow up success obtained in isolating the lead elements of the attacking enemy formations, the corps needs to be able to exploit advantages gained by the Alliance. To enable continued success, it must provide its units the necessary support to conduct operations against an enemy's ground forces that result in a return by enemy forces to their territory and their assumption of a less threatening posture.<sup>32</sup>

**Corps during de-escalation and return to noncrisis competition.** The highest priority of the corps remains the direction of the tactical fight against a peer enemy's forces. The corps will continue to focus on defeating enemy maneuver forces, the denial of key objectives, and the establishment of positions that give NATO an advantage during negotiations to end the conflict.

The corps fires command, supported by divisional fires assets, continues to conduct operations to neutralize and/or defeat enemy mid- and short-range fires. This sets the conditions for the corps to continue to maneuver its subordinate divisions as they execute the close fight against enemy maneuver forces. The corps and its subordinate units maintain, protect, and secure lines of communication with dedicated assets, masked by obscurity and deception operations to ensure survivability. The adequacy of support to ensure success in the form of personnel, equipment, and supplies cannot be understated. Additionally, the corps conducts reconstitution operations to regenerate combat power and begins the integration of any still deploying units into combat operations and consolidation efforts.

The focus of operations shifts to the corps as violence subsides during the consolidation of gains. The corps initially conducts deliberate planning and preparation to consolidate gains following the tactical success of its subordinate divisions. While eventually

divisions, and at the completion of large-scale combat, all units conduct activities to consolidate gains, the corps is responsible for overall planning, preparation, execution, and assessment to allow divisions to remain focused on retaining the initiative and maneuvering without a loss of momentum. Consolidation of gains entails those activities that, combined, make temporary tactical successes enduring; therefore, winning the close fight—tactical success—is of first importance. However, the tactical success will have been in vain without full and continuous consideration to the consolidation of operational and strategic gains. Activities to consolidate gains require a balance between security and stability tasks as well as influencing key audiences to support coalition and host-nation political and security forces operating in the area of operations. The corps, with augmentation, may transition to a joint task force designed to coordinate with interagency partners from various NATO nations and international organizations to begin extensive reconstruction and restore essential services. It may be required to remain in the theater for a significant period to ensure stability while retaining the capability to renew offensive operations rapidly should hostilities resume.<sup>33</sup>

## Conclusion

The ability of 1 (GE/NL) Corps to fulfill the warfighting corps role in the conduct of large-scale combat operations underpins the credibility of the Alliance's deterrence. However, to successfully deter or prevail in armed conflict, 1 (GE/NL) Corps and the other graduated readiness forces (land) need to continue to develop the required capabilities at the capacity needed to be a capable of conducting large-scale combat operations. The ability to employ these formations as described earlier requires realistic training and exercises that approach the intensity of modern operations, and finally, an aggressive warrior mindset focused on defeating any potential enemy. This is different from previous experience in non-Article 5 operations in which a greater emphasis was placed on other qualities and capabilities. The more professional we become in fulfilling the warfighting role, the more credible our efforts will be. In short, readiness and demonstrated warfighting competence are the foundation of effective deterrence.

Today again, deterrence is the key to preventing conflict because an aggressor must realize that the consequences for violent acts would be his defeat. NATO will remain the most powerful military alliance that

has ever existed in history. If we maintain our cohesion, no potential enemy will be able to successfully attack any alliance member. 1 (GE/NL) Corps will continue to provide its contribution in this context. ■

## Notes

1. 1 (GE/NL) Corps, "Corps Vision" (2019).
2. 1 (GE/NL) Corps's path to achieve readiness as a Warfighting Corps is detailed in 1 (GE/NL) Corps OPLAN 2027.
3. NATO Standardization Office, s.v. "formation," accessed 2 March 2022, <https://nso.nato.int/natoterm/Web.mvc>. NATO defines formation as "an ordered arrangement of troops and/or vehicles for a specific purpose."
4. For example, the U.S. Army's AimPoint and WayPoint Force, or that found in Jack Watling and Sean MacFarland, *The Future of the NATO Corps* (London: Royal United Services Institute for Defence and Security Studies, 2021), accessed 2 March 2022, <https://www.ousa.org/sites/default/files/SR-2021-The-Future-of-the-NATO-Corps.pdf>.
5. This structure is detailed in the 1 (GE/NL) Corps discussion paper, *1 (GE/NL) Corps as a Warfighting Corps* (7 April 2021), and was validated through the Quick Rider series of exercises and studies conducted by 1 (GE/NL) Corps throughout 2021.
6. U.S. Army Futures Command (AFC) Pamphlet 71-20-1, *U.S. Army Concept for Maneuver in Multi Domain Operations 2028* (Fort Eustis, VA: Army Futures Command, 2020), 39, accessed 2 March 2022, <https://api.army.mil/e2/c/downloads/2021/01/20/2fbec-ccc/20200707-afc-71-20-1-maneuver-in-mdo-final-v16-dec-20.pdf>; 1 (GE/NL) Corps, *Warfighting Concept: The Conceptual Framework of Corps Operations* (2020), 14, 18; 1 (GE/NL) Corps, *Corps Operating Concept: The Conduct of Corps Operations* (2022), 25; U.S. Army Futures Command, *Executive Summary: The Battlefield Development Plan 2019, "Field Army, Corps, and Division in Multi-Domain Operations 2028"* (Fort Eustis, VA: U.S. Army Futures Command, Joint & Army Concepts Division, 2020), 2–3, accessed 2 March 2022, <https://www.armyupress.army.mil/Portals/7/military-review/Archives/English/JA-20/Executive-Summary-The-Battlefield-Development-Plan-2019-Finalv2.pdf>.
7. 1 (GE/NL) Corps as a Warfighting Corps.
8. Ibid., 25.
9. 1 (GE/NL) Corps, *Warfighting Concept*, 10, 50; Watling and MacFarland, *The Future of the NATO Corps*, 5, 9; 1 (GE/NL) Corps, *Corps Operating Concept*, 25.
10. 1 (GE/NL) Corps, *Corps Operating Concept*, 25.
11. Simultaneous multi-echelon convergence can be found in the AFC Pamphlet 71-20-1, *U.S. Army Concept for Maneuver in Multi Domain Operations 2028*, 22; 1 (GE/NL) Corps, *Corps Operating Concept*, 20, 21, 25, 40.
12. 1 (GE/NL) Corps, *Corps Operating Concept*, 25; 1 (GE/NL) Corps, "Corps Vision" (2019); German Army, *Truppenfuehrung* (May 2018), 35.
13. 1 (GE/NL) Corps, *Warfighting Concept*, 13, 25.
14. These lessons were validated during 1 (GE/NL) Corps Functional Integration Training (Deep Operations) and a series of map exercises conducted in 2021. They were codified in the 1 (GE/NL) Corps, *Corps Operating Concept*, 26; also see AFC, *Executive Summary: The Battlefield Development Plan 2019*, 3.
15. Ibid.; 1 (GE/NL) Corps, *Warfighting Concept*, 14–15.
16. 1 (GE/NL) Corps, *Corps Operating Concept*, 27; AFC Pamphlet 71-20-1, *U.S. Army Concept for Maneuver in Multi Domain Operations 2028*.
17. German Army, *Truppenfuehrung*, 50. Unlike a U.S. Army corps, 1 (GE/NL) Corps is multinational in the organization of its staff, corps troops, and subordinate formations for which there is no set common structure.
18. 1 (GE/NL) Corps, "Rear Area Concept" (draft); and lessons learned from the Battlespace Management Map Exercise conducted on 16 July 2021.
19. This is an expansion of the concept of echeloned maneuver found in AFC Pamphlet 71-20-1, *U.S. Army Concept for Maneuver in Multi Domain Operations 2028*.
20. 1 (GE/NL) Corps, *Corps Operating Concept*, 26, 40. This reflects lessons learned during Exercise Strong Rider conducted 14–16 June 2021.
21. This reflects lessons learned during Exercise Strong Rider conducted 14–16 June 2021.
22. 1 (GE/NL) Corps, *Corps Operating Concept*, 23; AFC Pamphlet 71-20-1, *U.S. Army Concept for Maneuver in Multi Domain Operations 2028*, 82.
23. 1 (GE/NL) Corps, *Corps Operating Concept*, 27; U.S. AFC Pamphlet 71-20-1, *U.S. Army Concept for Maneuver in Multi Domain Operations 2028*, 23, 25.
24. 1 (GE/NL) Corps, *Warfighting Concept*, 29.
25. German Army, *Truppenfuehrung*, 35.
26. Peter L. Jones et al., *Russian New Generation Warfare: Unclassified Summary of the U.S. Army Training and Doctrine Command Russian New Generation Warfare Study* (Fort Eustis, VA: U.S. Army Training and Doctrine Command, 2017), accessed 2 March 2022, <https://www.armyupress.army.mil/Portals/7/online-publications/documents/RNGW-Unclassified-Summary-Report.pdf>.
27. Les Grau and Charles Bartles, *The Russian Way of War: Force Structure, Tactics, and Modernization of the Russian Ground Forces* (Fort Leavenworth, KS: U.S. Army Foreign Military Studies Office, 2016), 311; 1 (GE/NL) Corps, *Corps Operating Concept*, 33.
28. 1 (GE/NL) Corps Discussion Paper, *1 (GE/NL) Corps as a Warfighting Corps* (7 April 2021).
29. German Army, *Truppenfuehrung*, 54; 1 (GE/NL) Corps, *Corps Operating Concept*, 34.
30. Ibid.
31. German Army, *Truppenfuehrung*, 63; 1 (GE/NL) Corps, *Corps Operating Concept*, 34.
32. 1 (GE/NL) Corps, *Corps Operating Concept*, 37.
33. Ibid., 39.



Members of the Alabama National Guard's 46th Civil Support Team work a threat scenario created by Dugway Proving Ground's Special Program Division mobile training teams 18 June 2014. (Photo courtesy of the U.S. Army)

# On Biological War

Al Mauroni

In 1990, the U.S. political and military leadership was significantly challenged by the possibility that Iraq, having the fourth largest offensive chemical and biological weapons program in the world at the time, might use those unconventional weapons against U.S. forces and its allies massing in Saudi Arabia. For all practical purposes, there was no real capability to rapidly detect and identify the deliberate release of anthrax spores or other biological weapons, and the U.S. military did not have sufficient vaccines or therapeutics for such an event. Due to this severe neglect to biological defense,

former Secretary of State James Baker gave a formal letter to the Iraqi foreign minister stating that Iraq would “pay a terrible price” if it used chemical or biological weapons against the U.S.-led coalition.<sup>1</sup> Had Saddam Hussein decided to use biological weapons, it could have caused thousands of casualties. Fortunately for U.S. forces, he did not have a significant biological weapons capability and there was no use of those weapons.

Despite dark predictions of both nation-states and violent extremist organizations planning biological attacks against the nation, there has been no test of

the U.S. military's biodefense capability. A "biological taboo" resulting from decades of arms control discussions has held, despite the lack of a verification regime behind the Biological Weapons Convention (BWC).<sup>2</sup> Concerns about Iraq's biological weapons capability in 2003 evaporated a year later, with nothing substantive to find. Despite concerns about a domestic terrorist biological incident following the anthrax attacks in 2001, there has never been a mass casualty attack caused by biological organisms in the United States since then. The Nation's recent public health challenges in addressing the 2019 coronavirus pandemic (COVID-19) have caused questions as to whether the U.S. military is sufficiently prepared for an adversary that might be emboldened to use biological weapons against U.S. national security interests.

Despite the lack of any biological attacks or even threat of attacks over the past twenty years, the potential impact of a large-scale use of a contagious disease concerns enough people to call for new national strategies and improved response capabilities for biological threats. Current strategies aim to mitigate natural disease, to regulate biological research associated with the more hazardous biological diseases, and to improve the U.S. public health system to better respond to biological threats.<sup>3</sup> Yet despite the development of four national strategies for national biodefense over the past twenty years, the U.S. government has not significantly advanced its capabilities for protecting against and responding to biological threats, defined as including natural diseases, deliberate biological releases, and laboratory accidents. Despite the high-level attention to this threat, assessments of the Nation's capability to prepare for deliberate biological threats have not, however, been positive.

Unclassified assessments from the State Department and the Department of Defense (DOD) suggest that China and Russia could have a biological weapons capability, as could North Korea and Iran.<sup>4</sup> The lack of any actual use of biological weapons against the United States has perhaps diminished the concern that potential weaknesses exist. In the event of a future conflict with great powers, there is the chance that biological warfare could emerge as a significant threat, perhaps in a form unrecognized from Cold War experiences. Prior to attempting the implementation of yet another strategy to counter biological threats, the Army needs to establish the context of how adversaries would deliberately use

biological threats against U.S. national security interests. Once a rational appreciation of the threat is developed, one can then create a defense strategy that directly addresses deliberate biological releases. Importantly, such a strategy needs to be resourced and implemented to address the future challenges of a deliberate biological release, understanding that natural infectious diseases pose a competing priority.

## What's the Threat Today?

Counter to the hypothesis that the pandemic outbreak has revealed potential vulnerabilities to biological weapons, COVID-19 has not in fact acted like a biological weapon. As a result, the lessons that apply from this contemporary crisis toward a biological weapons attack are few. A pandemic outbreak, affecting the general population over a year's time, requires a different approach than military forces protecting themselves from a focused deliberate biological attack. COVID-19 is not lethal enough and does not incapacitate people quickly enough to qualify as a potential weapon, despite the more than 750,000 deaths caused over twenty-four months across the United States.<sup>5</sup> A biological disease that does not significantly impact young, healthy people and that is easily countered by a national vaccine program is not prime material for a weapon system. COVID-19 may have slowed down economic activities, but it is not an existential threat to the U.S. government. Despite the potential impact on national security, pandemic diseases are best addressed separately from biological defense concepts.

The U.S. military does anticipate the potential use of biological weapons in combat operations. In that light, the Department of Defense has a counter-weapons of mass destruction (WMD) strategy and chemical, biological, radiological, and nuclear (CBRN) defense concept to guide its efforts to prevent, protect against, and respond to adversaries using biological weapons.<sup>6</sup> The ratification of the BWC has significantly reduced the number of potential adversaries that might use traditional biological warfare (BW) agents, allowing one to focus on particular actors and military scenarios. The traditional biological warfare agents such as anthrax, pneumonic plague, smallpox, and tularemia are still potent candidates for future warfare. However, the employment of said weapons may look very different than envisioned during the Cold War. North Korea may



be the exception to this statement, as it is unclear how that nation would use unconventional weapons, but its operational concept for warfare appears to be based in an industrial age, massed firepower approach, similar to what NATO might have anticipated in the 1970s.<sup>7</sup>

China and Iran are assessed as not complying with the BWC, and Russia and North Korea are believed to have retained offensive biological weapons programs.<sup>8</sup> While we can understand the biological warfare model that North Korea might employ, this does not necessarily apply to Russia's and China's concepts of employment for biological weapons. The Cold War model of using massive amounts of biological agents against troop concentrations, major population centers, and large military sites such as air bases and seaports requires large-scale production, storage, and testing capability. As Russia and China have modernized their nuclear and conventional forces, they have also changed their approach toward military confrontations with the United States and partner nations. While preparing for the possibility of total war, both countries have focused on conducting regional operations against U.S. allies using methods that fall below the threshold of open conflict.<sup>9</sup> Their nuclear arsenals cast a coercive shadow over regional operations that allow those nations to

Members of the U.S. Marine Corps' Chemical-Biological Incident Response Force demonstrate anthrax clean-up techniques during a news conference 30 October 2001 on Capitol Hill in Washington, D.C. (Photo by Kenneth Lambert, Associated Press)

aggressively push and attain their political objectives. As a result, a clandestine biological weapons program can offer them a capability to perform single, small-scale chemical or biological weapons attacks on focused targets (facilities or individuals) while claiming to be compliant with the BWC.<sup>10</sup>

The former Soviet Union had a massive biological warfare program, unmatched by any historical measure. Despite extensive documentation of this program, the Russian Federation has not fully acknowledged the former Soviet Union BW program. The State Department has gone so far as to designate specific Russian government facilities as "acting contrary to the national security or foreign policy interests of the United States" through their association as military defense facilities associated with a BW research program.<sup>11</sup> These are not recent concerns. Analysts will point out that in 2012, then Prime Minister Vladimir Putin talked about creating "weapon systems that use different physical principles ...



(beam, geophysical, wave, genetic, psychophysical and other types of weapons).<sup>12</sup> However, it is unclear that this attributed quote referred to a return to developing biological weapons to support military conflict. In 2019, Putin directed a budget of 220 billion rubles (or \$3.3 billion) toward the development of genetic technologies that could support a wide range of applications (biomedical, agricultural, or biodefense).<sup>13</sup>

At the same time, the Russian government has claimed that the United States is building offensive BW laboratories in countries surrounding Russia through the Biological Threat Reduction Program. For instance, the “Lugar Center for Public Health Research” in Tbilisi, Georgia, was funded by U.S. defense funds, but its intent is to promote health security against natural infectious disease outbreaks.<sup>14</sup> In response to U.S. government accusations of China’s role in the COVID-19 outbreak, Chinese government officials have recently echoed the same claims that the U.S. government has created biological weapons near their borders.<sup>15</sup> This type of disinformation campaign falls squarely in the “gray zone” set of tools. Both China and Russia have ignored international efforts to prevent the proliferation of unconventional weapons technology and materials.

China’s position as one of the leaders of the global bioeconomy increases its potential for realized or latent advanced biological warfare capabilities. Beijing appears committed to becoming a leader in biotechnology, which holds the promise of myriad public health applications. Yet, many biotechnology applications are dual-use, capable of delivering both public health benefits and advances in biological warfare capabilities. As one top U.S. expert noted, China “is pursuing a very aggressive strategy to become the world leader in biotechnology.”<sup>16</sup> Sustained public and private investment in synthetic biology technologies needed for DNA sequencing and synthesis as well as gene editing have enabled China to develop a wide array of dual-use biotechnologies in the field of synthetic biology. Many experts anticipate that synthetic biology advances will enable the development of “new and novel biomaterials” to include advanced bioweapons.<sup>17</sup> As a 2020 Brookings Institution study noted, “The determination of China’s one-party state to become a leading player in biotechnology is reflected by the rapid growth in investment in the sector. Some estimates claim that collectively, China’s central, local, and provincial



China’s People’s Liberation Army (PLA) soldiers conduct a nuclear, chemical, and biological warfare exercise November 2021 in the Tibet Military Region, according to PLA news sources. The People’s Republic of China has an extensive program for studying virulent biological agents for the reputed purpose of medical research but which also have potential for military use. (Photo courtesy of the PLA)

governments have invested over \$100 billion in life sciences research and development.”<sup>18</sup> China’s sustained and sizeable government investment in domestic biotechnology has created an industrial base capable of developing and manufacturing a range of extant and novel biological warfare agents.

And while the possibility of developing novel biological warfare agents is present, it is more probable that China wants to use its biotechnology lead to produce superior commercial pharmaceuticals and to

enhance its military forces. There is always speculation that advances in the life sciences will drive an evolution in biological weapons, making them more lethal, more environmentally hardy, more targeted toward specific populations, or more able to confound contemporary detection systems. This belief used to be rooted in the 1970s rise of biotechnology, and then it was 1990s genetics driving the concerns. Today, it is the promise (and dangers) of synthetic biology. And while it is true

**Al Mauroni** is the director of the U.S. Air Force Center for Strategic Deterrence Studies at Air War College, Maxwell Air Force Base, Alabama. He has more than thirty-five years' experience in Department of Defense counter-weapons of mass destruction (WMD) policy and program development. In this role he oversees the development and execution of Air Force education, research, and outreach initiatives relating to counter-WMD and nuclear deterrence operations. Prior to his current assignment, he worked counter-WMD and chemical, biological, radiological, and nuclear defense issues for the Air Staff. Mauroni holds a master's degree in administration from Central Michigan University and a bachelor's degree in chemistry from Carnegie-Mellon University. He is the author of eight books and numerous journal articles, to include articles in *War on the Rocks*, *Modern War Institute*, *The Nonproliferation Review*, and *Joint Force Quarterly*.

that one could always improve characteristics of certain biological weapons, there are significant drawbacks as to such an approach.<sup>19</sup> Assuming that an adversary might develop altered biological weapons to be more operationally relevant, this would still be a violation of treaty (if it were China or Russia) and international norms. Modifying a biological organism to enhance its resistance to antibiotics might in turn reduce other desired characteristics, such as its lethality or dissemination qualities. Any use of a genetically modified organism would run the risk of direct attribution to a particular source.

Western military forces lack the capability to detect the deliberate use of biological weapons until after exposure. In addition, U.S. forces lack vaccines for a number of traditional biological warfare agents, let

alone engineered diseases.<sup>20</sup> Any nation with an advanced industrial capability can easily develop biological agents that can damage or destroy crops or livestock, in addition to targeting humans. There is no need for an overly sophisticated engineered biological warfare agent à la the latest James Bond movie, *No Time to Die*. And even if military forces had tactical biological detectors that could identify all biological warfare agents in a timely enough fashion to put on protective masks, traditional biological weapons would still be an effective strategic weapon against a civilian populace, its livestock, or cropland. There is no possibility that the United States and its Western allies can make biological weapons obsolete.<sup>21</sup> At the same time, we do not need to overexaggerate the threat of biological weapons as some Hollywood scripts portray them.

## What's the Right Concept?

There are several options that could be explored. The traditional approach has been to develop chemical and biological defense as a combined operational concept. Both chemical and biological warfare agents use similar delivery systems and target the human body's physiological response to hazards. Under the larger construct of countering WMD threats, the U.S. government can engage in arms control negotiations to limit biological weapons use, use preemptive strikes to target a nation's WMD capability, and respond to its use with protective equipment that limits the impedance of combat operations. None of these options are singular to biological threats. A second option is to task the medical community to identify and respond to both biological warfare attacks and natural disease outbreaks while limiting reliance on biological detectors and technical experts. The U.S. Air Force, for instance, endorses a biological defense concept that is separate from chemical defense and that relies on the medical community for initial detection and identification.<sup>22</sup> This is a very specific focus on biological threats that includes a conscious decision to limit investments in people and equipment in response to a lower probability of deliberate biological attacks. The Air Force concept is a subset of its counter WMD operations, as the Army's CBRN defense efforts are.

The U.S. Army recently released a biological defense strategy that calls for the "synchronized implementation" of both biological warfare defense and infectious natural diseases across the Army.<sup>23</sup> Interestingly, the



office responsible for implementing this strategy is the U.S. Army Nuclear and Countering Weapons of Mass Destruction Agency, not the Army’s chemical-biological defense specialists and not the Army’s medical experts who respectively own those areas of expertise. It is not immediately clear as to whether this strategy calls for the development of a stand-alone biological defense concept that combines capabilities for both infectious natural diseases and deliberate biological releases, or just a single agency that manages two very different concepts (counter-WMD and force health protection) that have a common scientific origin. The strategy details four “lines of effort” that include

- ◆ developing and managing talent and facilities that address biological threats;
- ◆ maintaining a biological common operating picture and awareness of biological defense forensics;
- ◆ building a readiness posture that includes protection, response, and training for biological defense capabilities; and
- ◆ directing modernization efforts for biological defense concepts and doctrine.

Will this new governance structure fundamentally change how the Army does biological defense? Given policy and budget direction, probably not.

New York Army National Guard Sgt. Casey Taylor, 2nd Weapons of Mass Destruction-Civil Support Team (2nd WMD-CST), and New York Air National Guard Master Sgt. Roger Yurko, 109th Airlift Wing emergency manager, investigate possible contamination 14 November 2019 during a training exercise at Stewart Air National Guard Base, New York. The 2nd WMD-CST supports civil authorities at man-made or natural disasters by identifying chemical, biological, radiological, and nuclear substances; assessing the consequences; and advising on response measures. (Photo by Master Sgt. Sara A. Pastorello, U.S. Air National Guard)

This is not the first time a military agency has suggested moving all biodefense activities into a portfolio for medical countermeasures for infectious diseases. There is an almost instinctual movement toward putting medical experts in charge of developing capabilities for countering all biological threats; however, that does not work for two reasons.

First, given a collection of biological threats—whether natural, deliberate, or accidental—medical leaders will always consider infectious natural diseases the most important concerns because of the large numbers of service members and their dependents who get sick from natural diseases. And there are a lot of infectious natural diseases to address. In 1990, the

U.S. military found itself without adequate vaccines for anthrax and botulin toxin when it was preparing to face an Iraqi military force that had an active chemical and biological weapons program. This was due to a deliberate decision to deprioritize research and development for biological warfare agents and focus instead on countermeasures for natural diseases such as chikungunya virus and diarrheal diseases.

Second, while the response to biological threats has often had a common core, the prevention and protection against biological threats certainly does not. While one can try to deter adversaries from using biological weapons, Mother Nature cannot be deterred. Protecting military forces from biological weapons during combat operations requires a completely different approach than protecting a military base's population from natural diseases. This requires a level of nuance to understand that a single biodefense concept cannot protect fundamentally different populations with different requirements and facing fundamentally different biological threats. There is a reason why there are different budgets and authorities for dealing with biological warfare agents, natural biological diseases, and biological research laboratory accidents.

## Problems with a Centralized Biodefense Enterprise

The primary purposes of any strategy document are to identify a specific mission or program, to identify policy objectives that should drive discrete programs, and to offer a plan to achieve those objectives. In the military, this is called "ends, ways, and means." Ideally, a strategy will also aid decision makers in moving resources toward those goals that require funding to achieve those objectives. So, the problem with a biological defense strategy that aims to address all biological threats—whether at the Army, the DOD, or national level—is that there are multiple agencies with budget elements who are already directed to address specific biological threats. I will argue that at least five biological threat sectors require consideration in any biological defense strategy:

- ♦ disease prevention as a function of public health,
- ♦ bioterrorism response as a function of homeland security,
- ♦ military biodefense as a function as countering WMD,

- ♦ biosurety as a function of laboratory practices, and
- ♦ biosecurity and biosafety as a function of agricultural and food industries.

None of these are new security concerns. Each has a dedicated government agency that focuses on a distinct threat using a congressionally approved budget. Because each biological threat sector already has a lead agency and agenda to pursue, the question comes as to what a centralized biological defense strategy would change or impact the direction of federal government or military biodefense programs.

Public health efforts addressing infectious biological diseases, to include aspects of disease prevention in the military's force health protection program, have been around for more than one hundred years. One of the challenges in the U.S. public health program is that it is federalized, meaning that states and local jurisdictions implement public health programs while the federal government provides research and funding for specific purposes. The Centers for Disease Control and Prevention (CDC) and the National Institutes of Health represent the largest government agencies in this area, putting tens of billions of dollars against infectious disease research, surveillance, and response. Within the military, the Army's Medical Research Institute for Infectious Diseases has a research and development program for infectious diseases to address potential biological threats to service members in U.S. and overseas theaters. Top threats include tuberculosis, measles, influenza, pneumonia, and malaria.

Bioterrorism response is a little more nebulous, since we have not seen a terrorist group successfully use a biological hazard to cause mass casualties in the United States since 1984. However, following the 2001 Amerithrax incidents, the concern that they might has thrown a few billion dollars a year toward the Department of Homeland Security and Department of Health and Human Services to develop response plans for the possibility.<sup>24</sup> The DOD needs to consider biological terrorism within its installation force protection plans, but for the most part, it is not an integral part of that effort due to the very low probability of such an incident. The DOD does have a massive CBRN Response Enterprise that would assist states and cities in any federal response to a biological terrorist incident. The top (realistic) biological threats usually include salmonella, ricin, botulinum toxin, sewage, and tainted body fluids.

Military biodefense has focused on protecting U.S. forces from biological warfare agents developed by adversarial nation-states for the purpose of combat operations. We have always envisioned biological weapons attacks as large-area coverage, mass casualty events on the battlefield. Because of technical challenges, military biodefense capabilities were largely lacking during the 1991 Persian Gulf conflict, leading to a crash program

can only provide suggestions on how the U.S. research and development community should implement good business practices. This area is not well funded (maybe \$500 million/year) or overseen from the federal level. The top threats for biosurety are too varied for listing, but in general, accidents are largely limited to individual researchers and not the general community surrounding a biological research lab.

“The top threats for biosurety are too varied for listing, but in general, accidents are largely limited to individual researchers and not the general community surrounding a biological research lab.”

in the mid-1990s to develop biological detectors and medical countermeasures for the services. Biological detection and vaccines were more readily available in 2003 as U.S. forces prepared for possible Iraqi biological weapons use. There is a central program office that manages all DOD biological defense programs, receiving maybe a half billion dollars a year for funding. Their top threats include anthrax, pneumonic plague, smallpox, tularemia, and brucellosis. The DOD's Biological Threat Reduction Program, which is more of an effort to secure other nations' laboratories and hospitals than biodefense, accounts for less than a \$300 million in annual funding over the past decade.<sup>25</sup>

Biosurety addresses the security and safety of laboratory research labs both across the United States and within the U.S. military. Unlike traditional biodefense efforts, biosurety is more about keeping biologicals safe from humans, as opposed to the other way around. The threat includes both the possibility that a researcher on the inside might deliberately or accidentally release a dangerous biological organism, or that an outsider might try to break in and steal them. There is also the danger of natural disasters or externally derived accidents to consider. The U.S. Army has had biosurety failures that resulted in CDC shutdowns at its Dugway Proving Ground (in 2015 due to anthrax shipments) and Fort Detrick laboratories (in 2019 due to unsafe laboratory practices). While the CDC has some oversight role for a small set of select agents and toxins, in general, the CDC

Biosecurity and biosafety challenges within the agricultural and food industries have been of two parts. First, many facilities have significantly large amounts of livestock or crops to protect against the introduction of any foreign disease that might wipe out their livelihood. In addition, foreign pests or animals could displace or eliminate native animals and crops. Second, there is the challenge of regulating food products as they are moved from the farm to the table, as the saying goes. Federal regulations aim to ensure that agricultural products used in meal production are both safe and accurately labeled. Both the Food and Drug Administration and U.S. Department of Agriculture have responsibilities to oversee this area, in addition to the Customs and Border Patrol. There is not a significant DOD equity in this area other than ensuring that meals prepared for the field are safe and free of contamination. Because Congress is very interested in ensuring that the public has safe food and a variety of different foods, this area gets funded between \$3 billion and \$4 billion a year. Its biological threats of concern include foot-and-mouth disease, swine flu, avian flu, wheat rust, and invasive species such as Asian carp, zebra mussels, cane toads, and brown marmorated stink bugs.

This is just the tip of the challenge of trying to address all biological threats—natural, deliberate, and accidental—under one Army, DOD, or national strategy. There are more complex discussions as to what would constitute a national biosurveillance effort—surprisingly, this would not be solely focused on infectious

biological diseases to humans, but also include diseases affecting animals and plants, as well as chemical or radiological hazards to any biological organism. There is the challenge of addressing the impact of future technologies such as “gain-of-function” and synthetic biology. Even after we identify all of the potential issues that surround “biological threats,” there is the question of who ought to lead the effort. The public health community claims that if it were better funded, it could address all natural disease outbreaks as well as respond to biological terrorism. The national security community feels that it needs to have a larger voice in this effort, given that these are foreign threats that impact the armed forces and other U.S. national security interests. And given the national security community’s funding and ability to quickly form new project offices, they could very well dominate the discussion, which could result in different priorities than what the public health community sees as important.

## Concluding Thoughts

The military’s primary concern should be on deliberate biological threats, but there is no question that it has been distracted by COVID-19 and the general topic of natural disease outbreaks. If the DOD’s Chemical-Biological Defense Program decides to move from working on countermeasures to biological warfare agents and focus instead on “threat-agnostic” systems that address all biological threats, the military will not get necessary detectors, protective ensembles, medical vaccines, or decontaminants for biological warfare agents due to the larger number and greater impact of natural infectious diseases. This is, in essence, what happened in the 1980s; because the military medical community was focused on research and development for infectious diseases and not biological warfare agents, U.S. forces were unprepared for biological warfare in 1990.<sup>26</sup>

Military concepts of future war assure us that biological and nuclear warfare are expected threats to U.S. forces.<sup>27</sup> In the case of a conflict with North Korea, it may not look that different than Cold War concepts of massive, large-coverage attacks on U.S. military bases. In the case of China and Russia, it is less clear what the future of biological war will be. As technology such as drone swarms, artificial intelligence, and synthetic biology continue to mature, the shape of biological warfare threats will evolve. One can assume that the traditional biological warfare agents will still be viable candidates, or possibly enhancements on their natural forms. Terrorist use of biological hazards may be limited to crude toxins and improvised delivery systems—still a threat to installation force protection measures, but not necessarily a mass casualty event. This future operating environment requires us to focus on enhancing the survivability of critical infrastructure—in particular, command and control, power projection, and logistics bases—and the resiliency of military operations while impacted by biological weapons.

The only way to succeed in moving forward in a future biological defense posture is not, then, to dilute the Army’s efforts by trying to manage the development of defensive capabilities for all natural disease outbreaks and deliberate biological attacks under a single general construct. There needs to be a laser-sharp focus on both pandemic preparedness and biological defense during combat operations. In addition, the DOD needs to ensure that its biological research and development laboratories have the best practices in place to avoid future shutdowns due to biosurety challenges. This is not an either/or discussion nor is it the time to radically revise how military forces accomplish biological defense. Instead, Army leaders need to engage in these discussions, despite the complicated technical nature of the topic, and ensure that future operations can be maintained despite the threat of biological weapons use. ■

---

## Notes

1. “Confrontation in the Gulf: Text of Letter from Bush to Hussein,” *New York Times* (website), 13 January 1991, accessed 21 December 2021, <https://www.nytimes.com/1991/01/13/world/confrontation-in-the-gulf-text-of-letter-from-bush-to-hussein.html>.

2. Office of Treaty Affairs, “Biological Weapons Convention,” U.S. Department of State, entered into force 26 March

1975, accessed 23 December 2021, <https://www.state.gov/biological-weapons-convention-text/>.

3. The White House, “American Pandemic Preparedness: Transforming Our Capabilities” (Washington, DC: The White House, 2021), accessed 21 December 2021, <https://www.whitehouse.gov/wp-content/uploads/2021/09/American-Pandemic-Preparedness-Transforming-Our-Capabilities-Final-For-Web.pdf>.

4. Terri Moon Cronk, "DOD Officials Warn of Increased Threat from Weapons of Mass Destruction," Department of Defense News, 13 February 2020, accessed 21 December 2021, <https://www.defense.gov/News/News-Stories/Article/Article/2083671/dod-officials-warn-of-increased-threat-from-weapons-of-mass-destruction/>.
5. "COVID Data Tracker," Centers for Disease Control and Prevention, accessed 22 December 2021, [https://covid.cdc.gov/covid-data-tracker/#trends\\_totaldeaths|tot\\_deaths|select](https://covid.cdc.gov/covid-data-tracker/#trends_totaldeaths|tot_deaths|select).
6. Department of Defense Strategy for Countering Weapons of Mass Destruction (Washington, DC: Office of the Secretary of Defense, 2014), accessed 22 December 2021, [https://dod.defense.gov/Portals/1/Documents/pubs/DoD\\_Strategy\\_for\\_Countering\\_Weapons\\_of\\_Mass\\_Destruction\\_dated\\_June\\_2014.pdf](https://dod.defense.gov/Portals/1/Documents/pubs/DoD_Strategy_for_Countering_Weapons_of_Mass_Destruction_dated_June_2014.pdf); Joint Publication 3-11, *Operations in CBRN Environments* (Washington, DC: U.S. Government Publishing Office, 2020), accessed 22 December 2021, [https://www.jcs.mil/Portals/36/Documents/Doctrine/pubs/jp3\\_11.pdf](https://www.jcs.mil/Portals/36/Documents/Doctrine/pubs/jp3_11.pdf).
7. John Parachini, "North Korea's CBW Program: How to Contend with Imperfectly Understood Capabilities," *PRISM* 7, no. 3 (15 May 2018), accessed 22 December 2021, <https://cco.ndu.edu/News/Article/1516496/north-koreas-cbw-program-how-to-contend-with-imperfectly-understood-capabilities/>.
8. "Part V: Other States' Compliance with and Adherence to Arms Control, Nonproliferation, and Disarmament Agreements and Commitments Pertaining to Biological Issues," in *2021 Adherence to and Compliance with Arms Control, Nonproliferation, and Disarmament Agreements and Commitments* (Washington, DC: U.S. Department of State), accessed 22 December 2021, [https://www.state.gov/2021-adherence-to-and-compliance-with-arms-control-nonproliferation-and-disarmament-agreements-and-commitments/#\\_Toc69385144](https://www.state.gov/2021-adherence-to-and-compliance-with-arms-control-nonproliferation-and-disarmament-agreements-and-commitments/#_Toc69385144).
9. Lyle Morris et al., *Gaining Competitive Advantage in the Gray Zone: Response Options for Coercive Aggression Below the Threshold of Major War* (Santa Monica, CA: RAND Corporation, 2019).
10. Christopher Ford, "Biosecurity, Biological Weapons Nonproliferation, and Their Future" (remarks, U.S. National Defense University, Fort Lesley J. McNair, Washington, DC, 11 April 2019), accessed 22 December 2021, <https://2017-2021.state.gov/biosecurity-biological-weapons-nonproliferation-and-their-future/index.html>.
11. "Part V," in *2021 Adherence to and Compliance with Arms Control, Nonproliferation, and Disarmament Agreements and Commitments*.
12. Aleksey Nikolsky, "Being Strong: National Security Guarantees for Russia," RT, 19 February 2012, accessed 22 December 2021, <https://www.rt.com/russia/official-word/strong-putin-military-russia-711/>.
13. Anna Nemtsova, "Is Putin's Fascination with Genetics Just Eugenics in Disguise?," *The Daily Beast*, 30 May 2019, accessed 22 December 2021, <https://www.thedailybeast.com/is-putins-fascination-with-genetics-just-eugenics-in-disguise/>.
14. Vladimir Isachenkov, "Russia Claims US Running Secret Bio Weapons Lab in Georgia," Associated Press, 4 October 2018, accessed 22 December 2021, <https://apnews.com/article/public-health-north-america-health-ap-top-news-in-state-wire-0cf158200e674f41bd3026133e5e043d>.
15. Julia Davis, "Russia, China Team Up to Peddle Insane US COVID Lab Theory," *The Daily Beast*, 9 April 2021, accessed 22 December 2021, <https://www.thedailybeast.com/russia-china-team-up-to-peddle-insane-us-covid-lab-theory>.
16. Many Mayfield, "China Pursuing 'Aggressive' Biotechnology Strategy," *National Defense* (website), 9 July 2020, accessed 22 December 2021, <https://www.nationaldefensemagazine.org/articles/2020/7/9/china-pursuing-aggressive-biotechnology-strategy>. Quote attributed to Dr. Tara O'Toole, a senior fellow and executive vice president at In-Q-Tel.
17. Michael Morrell and Ken Wickiser, "West Point Biochemist Warns about Threat of Bioweapons," 20 January 2021, in *Intelligence Matters*, produced by Paulina Smolinski, podcast, accessed 22 December 2021, <https://www.cbsnews.com/news/bioweapons-threat-synthetic-biology/?tag=CNM-00-10aac3a>.
18. Scott Moore, *China's Role in the Global Biotechnology Sector and Implications for U.S. Policy* (Washington, DC: Brookings Institution, April 2020), accessed 22 December 2021, [https://www.brookings.edu/wp-content/uploads/2020/04/FP\\_20200427\\_china\\_biotechnology\\_moore.pdf](https://www.brookings.edu/wp-content/uploads/2020/04/FP_20200427_china_biotechnology_moore.pdf).
19. National Research Council, *Biotechnology Research in an Age of Terrorism* (Washington, DC: National Academies Press, 2004), 22–23.
20. Matthew Cox, "The Next Major Battlefield Threat Facing US Troops May Be Undetectable," *Military.com*, 2 September 2020, accessed 22 December 2021, <https://www.military.com/daily-news/2020/09/02/covid-19-may-force-pentagon-pay-attention-major-weak-spot-bioweapons.html>.
21. Paul Rhien, "Can the U.S. Make Bioweapons Obsolete?," *Sandia LabNews*, 12 March 2020, accessed 22 December 2021, <https://www.sandia.gov/labnews/2020/03/12/bioweapons/>.
22. Air Force Doctrine Publication 3-40, *Counter Weapons of Mass Destruction (WMD) Operations* (Maxwell Air Force Base, AL: LeMay Doctrine Center, 2016), Appendix A, "Preparing the Force," accessed 22 December 2021, [https://www.doctrine.af.mil/Portals/61/documents/AFDP\\_3-40/3-40-D14-CBRN-App1-Preparing.pdf](https://www.doctrine.af.mil/Portals/61/documents/AFDP_3-40/3-40-D14-CBRN-App1-Preparing.pdf).
23. U.S. Army, *Army Biological Defense Strategy* (Washington, DC: Headquarters, Department of the Army, 2021), accessed 22 December 2021, [https://armypubs.army.mil/epubs/DR\\_pubs/DR\\_a/ARN32553-SD\\_04\\_STRATEGY\\_NOTE\\_2021-01-000-WEB-1.pdf](https://armypubs.army.mil/epubs/DR_pubs/DR_a/ARN32553-SD_04_STRATEGY_NOTE_2021-01-000-WEB-1.pdf).
24. "Amerithrax or Anthrax Investigation," Federal Bureau of Investigation, accessed 23 December 2021, <https://www.fbi.gov/history/famous-cases/amerithrax-or-anthrax-investigation>.
25. Under Secretary of Defense (Comptroller), *Defense Budget Materials* (Washington, DC: Department of Defense, 2013, 2016, 2018, 2021), accessed 17 February 2022, <https://comptroller.defense.gov/Budget-Materials/>.
26. Yasmin Tadjdeh, "Pentagon Reexamining How It Addresses Chem-Bio Threats," *National Defense* (website), 27 October 2021, accessed 22 December 2021, <https://www.nationaldefensemagazine.org/articles/2021/10/27/pentagon-reexamining-how-it-addresses-chem-bio-threats>.
27. *Joint Operating Environment 2035: The Joint Force in a Contested and Disordered World* (Washington, DC: Joint Chiefs of Staff, 14 July 2016), accessed 22 December 2021, [https://www.jcs.mil/Portals/36/Documents/Doctrine/concepts/joe\\_2035\\_july16.pdf](https://www.jcs.mil/Portals/36/Documents/Doctrine/concepts/joe_2035_july16.pdf).

# A Mission of Mercy amidst Terror, Death, and Despair

## The Story of the National Relief Boat in the Great Yellow Fever Epidemic of 1878

Maj. James D. Campbell Jr., U.S. Army, Retired

**T**oday's coronavirus pandemic has been historic in its scope and in the anxiety it has created in the general population. One result is that the Army has been called upon to manage distribution, and in some cases the administration, of the vaccine in relief of the pandemic, as well as other efforts in support of pandemic relief. Designating the Army as a relief provider is not new or unique to this medical crisis. It recalls a similar, and in some ways, a much more desperate attempt to relieve the suffering of a great epidemic. The Army's intent to deliver vaccines across the country to significant points of need is reminiscent of the national relief boat effort that was conducted during the great yellow fever epidemic of 1878.

Between July and October 1878, a scourge hit the Mississippi Valley the likes of which the Nation had never seen. It was a yellow fever outbreak, which at that point was by far the worst epidemic in U.S. history. Yellow fever is a horrible disease. Also called "Yellow Jack" and "Black Vomit" among others, the names called out the most dreadful symptoms of the disease. Patients developed yellow skin and their eyes turned

yellow. Abdominal pain and dark, often bloody vomiting; bleeding from the nose, mouth, and eyes; liver and kidney failure; and brain dysfunction, including delirium, seizures, and coma, were telltale signs of this deadly plague. The disease was not only deadly, but it was also terrifying to behold.

The first official yellow fever death occurred in New Orleans on 10 July, though there were indications that deaths occurred as early as 27 May that were simply not reported.<sup>1</sup> The fever steadily spread up the Mississippi River to Memphis, where the first death was recorded in early August. By mid-August, news of the epidemic was reported daily across the Nation and the world. Major newspapers like the *New York Times* were publishing daily reports and grim accounting of the pestilence from most of the larger towns and cities along the river. After many daily reports recounting numbers of cases and deaths, the *New York Times* eventually simply announced that the number of deaths was decreasing, not because the disease was subsiding, but rather, from the scarcity of people left to become its victims.<sup>2</sup>



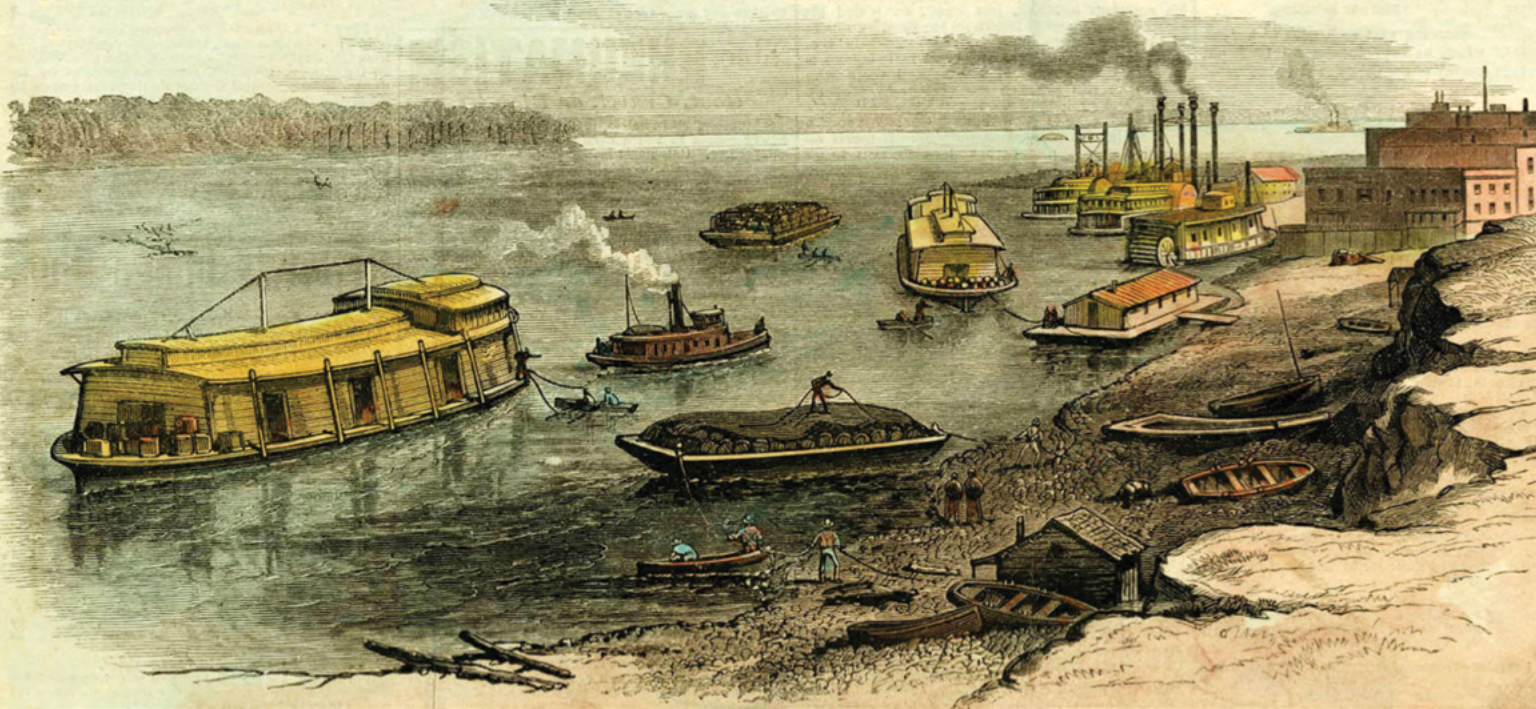

Boats bring food into the city during the Memphis quarantine. The 1878 yellow fever outbreak in Memphis, Tennessee, killed more than five thousand people in the city. (Photo by Science History Images/Alamy Stock Photo; original from *Harper's Weekly*, 1879)

## A Nationwide Cry for Help

On 9 September, a group of prominent citizens from the region, including the president of the New Orleans Chamber of Commerce and a congressman from Louisiana, sent a telegram to every city in America, pleading for all possible aid. As part of their message, they recounted the plight along the Mississippi, which reflected the economic strain as well as the lethal fever. They reported that “all business is entirely suspended ... south of Memphis, over fifty steamboats are tied up and their crews discharged. The longshoremen and the gang of stevedores and laborers ... are without employment. Four great lines of railroad are paralyzed, and their employees are idle.”<sup>3</sup> And, “these employees are poor, and dependent upon their labor for support ... [they] have no means to get away from the pest ridden cities. For them there is no labor, no wages, no bread, nothing but death or starvation.”<sup>4</sup> There were, in fact, no trains or steamboats operating in the region at all. This created widespread lack of food, mail, and medical supplies, compounding the suffering in the region.

The details of the citizens’ committee’s cry for help only served to reinforce the news that was reported out of the region. On 18 August, the *New York Times* reported the results of the fever in Grenada, Mississippi: “Picture a town of 2200 inhabitants reduced in one short week to 200 with only 30 or 40 well ones, and this

is the scene before you.”<sup>5</sup> On 24 August, a reporter from the *Vicksburg Herald*, a veteran of the Civil War, wrote,

God only knows the ghastly sights and scenes of pain transpiring in Vicksburg tonight. We have seen the horrors of battlefield, have tasted the sorrows and deprivations of prison life, have buried comrades and friends on lonely, far-off battle fields, but we have never, in a varied and eventful life, witnessed anything which so awakened the sensibilities of our nature. May God have mercy on us all.<sup>6</sup>

And on 28 August, the *New York Times* described Canton, Mississippi:

Not a single business house is open except two drug stores ... The Mayor and family are sick, the Board of Aldermen have fled. The Court-house is locked up and the officers have fled to some safe place. Nothing but hearses and coffins are to be seen in the streets.<sup>7</sup>

These are not exceptional reports, but reflect the common reporting out of the region. The devastation was incredible and widespread. Memphis, for example, the second largest city in the south in 1878, started the month of July with a population of forty-seven thousand. By September, that number had fallen to just nineteen thousand, when over twenty-five thousand Memphians fled the city.<sup>8</sup> Of the remaining population,

seventeen thousand had the fever. And, about 30 percent of those infected died of the fever.<sup>9</sup> Imagine reading this in today's media: "A man on Poplar Street yesterday cowardly deserted his wife and daughter ... with the fever; if he isn't dead, somebody ought to kill him."<sup>10</sup> This came from the *Memphis Appeal*, a newspaper where out of forty-two employees, nineteen died, twenty-one were bedridden, and only two survived not stricken by the fever.<sup>11</sup> By the end of August, the *New York Times* headlines read, "The Southern Fever Terrors. New Orleans Doctors Abandon all Hope."<sup>12</sup> This was the level of desperation and despair engulfing the region.

## The Nation Responds

Due to the difficulties of a solely governmental effort to rapidly respond to the crisis, particularly the fact that Congress was out of session, a National Relief Commission was formed. The commission consisted of a collection of prominent citizens including federal Judge Arthur MacArthur Sr. (father of Lt. Gen. Arthur MacArthur Jr. and grandfather of Gen. Douglas MacArthur); Gov. Alexander R. Shepherd, former governor of the District of Columbia; and Surgeon General John M. Woodworth, United States Marine Hospital Service (the modern-day Public Health Service).<sup>13</sup> The commission, which today might be characterized as a joint task force, was established to permit a rapid response that could incorporate both government efforts and charitable contributions to the cause. The chairman of the commission, Shepherd, worked directly with Secretary of War

George W. McCrary and Brig. Gen. Robert MacFeely, the commissary-general of the Army, to provide relief to the region through the distribution of needed food, medicines, and other goods to the stricken region. Money and supplies were solicited in support of the relief effort and a plan quickly devised: a national relief boat.

This plan was to send a steamboat, dispatched from Saint Louis, laden with provisions, ice, and medicine,

to provide relief from Memphis down to Vicksburg and beyond, while additional efforts would be made traveling up river from New Orleans.<sup>14</sup> The official report indicated that the expedition went no further south than Grand Gulf, "because we learned at Vicksburg that the points below were supplied from New Orleans."<sup>15</sup>

The first boat selected for the journey was the *Eagle*, a midsized boat with a capacity of 150 tons. But the overwhelming support in both funds and goods were too much for the *Eagle*. The commission had to find a larger boat and settled on the steamer *John M.*

*Chambers*, a stern-wheel boat with a capacity of 300 tons. The *Chambers* was chartered on 2 October for a departure date of 4 October.<sup>16</sup>

The next step, provisioning the boat, was already in progress. Lt. Col. (Brevet Brig. Gen.) Edward Beckwith was the commissary general for the Army's Division of the Missouri in 1878. On 26 September, he was instructed by MacFeely to assist a subcommittee of the commission: "Afford this sub-committee any aid in your power to enable them to secure supplies at



The Catholic Sisters of Charity tended the sick and dying in Memphis, Tennessee, during the fever outbreaks of the 1870s. (Photo courtesy of the Tennessee State Library and Archives via Digital Library of Tennessee)

the lowest rates.”<sup>17</sup> Money was sent from nearly two dozen cities and organizations from across the country. Additionally, goods such as bedding and clothing were sent from as far away as Philadelphia and New York.

The subcommittee consisted of the chairman of the commission, Gov. Shepherd; assistant surgeon H. M. Keyes of the United States Marine Hospital Service; United States District Attorney William H. Bliss, the treasurer for the expedition; and John T. Mitchell, a commission member with extensive shipping and supply experience.<sup>18</sup> Together with Beckwith, they were able to procure, or receive from donated cash and material contributions, “aggregating \$20,000 in money (besides a large quantity of merchandise), has been expended in the charter of a steamer and the purchase of an assorted cargo of such provisions, clothing, bedding, medicines, and ice.”<sup>19</sup> When the boat left Saint Louis, the reported value of the cargo itself was more than \$20,000, an amount that today would have a projected worth of over \$50 million.<sup>20</sup>

In 1878, there was no effective treatment or cure for yellow fever. The source was unknown and was attributed to many things from bad air to human-to-human contact. None of the experts at the time suspected that it was a mosquito-borne illness. Consequently, the treatments used were wildly divergent, and by today’s standards many were barbaric and lethal in their own right.

The Howard Association, named after eighteenth-century philanthropist John Howard, was a collection of

autonomous groups formed specifically to fight yellow fever outbreaks. The medical director of the Memphis Howard Association, Robert Mitchell, set a strict protocol of treatment for his doctors to follow. First, the patient was to be given Calomel, a mercury-based medicine that could cause mercury poisoning if not carefully administered. Next was a mustard footbath followed by sponge baths of whiskey and water until the person’s temperature

fell below 102 degrees. This was followed by two doses of quinine and then ten days on a diet of milk, lime-water, and chicken broth.<sup>21</sup> Quinine was an effective treatment for malaria but not for yellow fever, and it could promote nausea and delirium, both common symptoms of the fever.

Some doctors were proponents of warm teas; drinks like black, watermelon, or orange-leaf tea were a preferred treatment. Others proposed lemonade and champagne and other wines. To promote the action of the kidneys, the salts of potash or ammonia, with or without the spirits of nitric ether, were commonly used.

Wines as well as distilled and fermented liquors were almost always used during convalescence.<sup>22</sup>

Many doctors published their methods for their colleagues’ consideration. A certain Doctor Gibson, from Yazoo City, had a particular yellow fever prescription of a mixed solution of arsenic, quinine sulphate, and cherry laurel water with a few drops of sulphuric acid to dissolve the quinine. The yellow fever patient was to take a teaspoonful of this remedy after every meal.<sup>23</sup> Doctor W. H. Falls of Cincinnati was a proponent of



A Howard Association physician of Memphis, Tennessee, visits patients stricken with yellow fever and communicates the dire situation that the city faced during its 1870s public health nightmare. (Photo courtesy of the Tennessee State Library and Archives via Digital Library of Tennessee)

vigorous trial and error to find a treatment. In one trial, he administered massive dosages of chloride of mercury to find the right solution. He tried it on four patients, and all four died.<sup>24</sup> The *Daily Picayune* summed it up like this: “Doctors disagree on the treatment, but under the different kinds of treatment the result appears the same. The grave swallows up all alike.”<sup>25</sup>

Because of the broad spectrum of opinions on treatments for the fever, the subcommittee sought to provision the boat with a range of medicines and other items to meet the divergent theories of care. As part of the medical supplies, the cargo included two hundred cases of medicine selected for “special use of yellow-fever patients,” 105 tons of ice, and twenty-four cases of lemons, as well as 1,500 bottles of champagne, six cases of brandy, four cases of sherry, and 121 gallons of whiskey.<sup>26</sup> For disinfectants, they carried twenty-five barrels of turpentine, two crates of carbolic acid, and twenty-five barrels of chloride lime. For general relief, there were large supplies of food (five tons of bacon alone), dry goods, hardware, and housekeeping goods.<sup>27</sup>

In addition to acquiring a boat and the requisite supplies, manning the expedition was the final step in the preparation and posed its own challenge. The trip was considered by many to be a suicide mission. The Army requested volunteers for command of the expedition. Two officers volunteered and were selected for the mission. The expedition commander was 1st Lt. Hiram H. Benner, 18th Infantry, who had commanded

**Maj. James D. Campbell Jr., U.S. Army**, retired, is a defense contractor and works as a volunteer at the National Museum of the United States Army. His great-great-grandfather was George H. Mitchell, the post office volunteer on the steamship *John M. Chambers*. He first became aware of the epidemic and the relief boat effort when he found a short journal of Mitchell's among some old family papers.

a company during the Civil War, was twice a prisoner of war, and had since spent the last thirteen years on the frontier and in the deep South.<sup>28</sup> His second-in-command was 2nd Lt. Charles Hall, 13th Infantry, only two years out of West Point, who would also serve as the commissary department head, handling the distribution of all nonmedical supplies.<sup>29</sup> At the beginning of the mission, a member

of the expedition noted that Hall “was the right man in the right place.”<sup>30</sup> This was a prophetic observation that would prove out in a matter of days on the voyage. Assistant surgeon Keyes oversaw the medical portion of the mission and distribution of all medicines and medical supplies. He had as his assistant a druggist named Henry L. Kessler. Frank Reilly, from Chicago, was aboard as an observer and assistant physician along with Keyes.<sup>31</sup> Reilly had served as the regimental surgeon of the 26th Illinois Infantry during the late war. In addition to assisting Keyes, he wrote dispatches to the *Chicago Times* newspaper during the expedition.<sup>32</sup> The boat's captain was Vincent M. Yore. The full complement of men aboard was forty-one on its departure.<sup>33</sup>

## The National Relief Boat

The plan called for the *Chambers* to leave Saint Louis on 4 October for points south. The *Saint Louis Dispatch* reported on the departure:

She went with the good wishes of the whole nation and a million prayers are going up for the safe return of the men aboard. To go was something like walking into the jaws of death, for few have gone from the North into the plague stricken land who lived to return.<sup>34</sup>

The *Chambers* left Saint Louis at 11:00 on 4 October for a journey of over seven hundred miles to Vicksburg but stopped only a few minutes later at the arsenal below the city. Due to the high value of the cargo, there was some concern that the cargo might be at risk from river pirates or other criminal bands. The arsenal issued twenty carbines and two thousand rounds of ammunition for the crew to protect the cargo.<sup>35</sup> After the *Chambers* left the arsenal and only a few hours into the voyage, the boat had to stop to repair the wheel and rudder. That night the boat laid over near Chester, Illinois, due to the dangers of navigating that part of the river in the dark. Shifting sand bars, snags, and drifting logs made night travel an unnecessarily dangerous threat to the success of the mission.

On 5 October, the *Chambers* sailed to Cairo, Illinois. They stopped there to take on more donations for support of the relief effort and more supplies for the boat itself. In addition to three hundred bushels of coal for the steamer's boiler, they procured one hundred yards of bagging cloth. The cloth was hung around the edge of the boiler-deck to create a sort of screen to protect the crew.

The boat was disinfected three times a day by sprinkling chloride of lime around the boat and by saturating the cloth around the deck with turpentine to ward off the fever.<sup>36</sup> These were particularly extraordinary measures considering that one of the primary sources of risk for steamboats was fire. Ironically, less than six years later, the *Chambers* would be destroyed by fire a little north of New Orleans.<sup>37</sup>

On 7 October, the *Chambers* reached Memphis. Benner reported that “Memphis looks like a grave ... The city looks mournful in the extreme, appears gloomy and desolate, with a funeral pall overhanging it and dread disease lurking in the shadow.”<sup>38</sup> The *Memphis Herald* recalled the arrival, “being the first incident in river [travel] ... that has transpired within the past sixty days. In other words, river business would be completely dried up but for the great event of to-day, which will be hailed all along the river, as the *Chambers* passes down, with eager delight.”<sup>39</sup> In Memphis, the boat took on its final crew member and ten tons of mail for distribution along the route. George H. Mitchell brought aboard the mail, which had been gathering for two months, to be delivered down the river. He became the forty-second and final member of the expedition.<sup>40</sup> During their collection in Memphis, the mail bags had been carefully fumigated with sulfur every night in the Memphis post office, but once on board, like the shroud around the deck, the mail bags were sprinkled with turpentine three times each day to disinfect them.<sup>41</sup>

After its departure from Memphis, the *Chambers* sailed down the river delivering mail and dispensing medicines and supplies along the way. They made an average of about ten attempts to land each day. However, every day the crew encountered obstacles that prevented them from landing or from providing any relief items to that point. Sometimes they found abandoned landings with no one there to receive any supplies or mail. At one landing point there was a large sign that read, “don’t want anything, keep away from here.”<sup>42</sup> At others, the quarantine was absolute with “armed men stationed to enforce

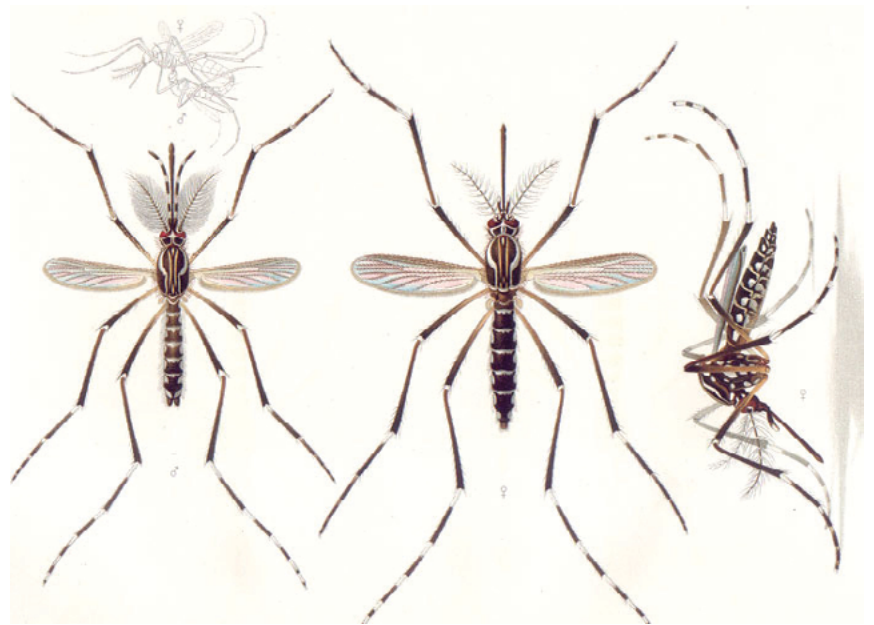

Color print of the yellow fever or dengue mosquito *Aedes aegypti* (then called *Stegomyia fasciata*, today also *Stegomyia aegypti*). (Photo courtesy of Wikimedia Commons)

same,” or “a squadron of Cavalry with loaded guns compelled us to leave, would not receive mail, papers or nothing.”<sup>43</sup> Even though they had taken the precaution of arming against robbers of the valuable cargo, there was never an actual threat. The overwhelming fear throughout the region of any contact with outsiders rendered even the thought of going to the boat so terrifying that no one was willing to venture close, much less attempt to board or rob the boat.

Along the route, the crew witnessed what the reports in the newspapers had described. At almost every stop they got the report of the sick, dead, and dying and the ominous warning of what to expect downriver, “fever below.” Reilly reported that the national relief boat often moored at the “deserted Levees of the Mississippi.”<sup>44</sup> What had been thriving river towns were now simply ghost towns. He also observed that many of their stops were greeted by the “tearful gratitude of the survivors.”<sup>45</sup> At Greenville, Mississippi, George Mitchell recorded that the “place has suffered terribly and that out of a population of [about 1400] who remained in the city, there was 900 cases and 277 deaths.”<sup>46</sup>

By 13 October, the *Chambers* had reached Vicksburg, having made over thirty stops along the way, some for medicine, some for supplies, and every stop for mail.<sup>47</sup> In Vicksburg, Hall delivered all of

the remaining cargo to the Howard Association there. The morning of the 13th, Benner became sick and was confined to his quarters. The watchman was stricken on the 14th. The *Chambers* crossed the river and the crew waited to see if Benner's condition would improve. Four days later, he was dead from yellow fever.<sup>48</sup> The captain of the boat, Yore, was stricken and sent ashore to a hospital in Vicksburg. The watchman died on the same day as Benner. Benner died at 2:30 in the morning on 17 October. He laid in state from noon until 4:00 p.m. and his funeral was conducted immediately afterward.<sup>49</sup>

The *Chambers* stayed in Vicksburg following the funeral in search of a new captain and pilot for the return to Saint Louis, since Yore had the fever and the pilots refused to stay with the boat. Reilly reported that immediate flight was their only hope, so the delay caused very grave concern among the remaining members of the crew.<sup>50</sup> Fortunately, they were able to leave the next afternoon for the return trip, but the pilots that they brought on board were hardly recovered from the fever themselves. Hall was now in command and would see the boat safely back to its port in Saint Louis. He described the return as "a slow and tedious crawling up the river."<sup>51</sup> There were issues with the engine as well as fog and river obstacles. They were obliged to steam only during the day due to the condition of the river and of the pilots. They lost another pilot at Memphis and had to steam to Cairo, Illinois, before they could find a replacement. The boat finally arrived at the quarantine station below Saint Louis at about 9:00 a.m. on 29 October.

## Aftermath

The *Chambers*, following an inspection and thorough disinfection, arrived back in Saint Louis on the afternoon of 29 October. Benner and the head watchman



Over twenty-five thousand citizens evacuated the city of Memphis in 1878. (Photo courtesy of Historic Memphis)

J. M. Dalton were dead. Yore had been left down river with the fever but would survive. Other members of the crew were also left behind due to the fever and in some cases fear of continuing. The boat reached Saint Louis with less than three quarters of its original crew.

While the relief boat did not bring healing relief for the suffering, it was seen as a great success. Army leadership endorsed an order that stated in part that it "fulfilled [its] perilous mission in a manner worthy of praise and admiration."<sup>52</sup> The Congressional Record described it as a "permanent, lasting record in the archives of ... a great nation's appreciation of a courage and heroism that has no precedent in all its annals and no parallel in all the history of noble deeds."<sup>53</sup> George Mitchell's final journal entry reflected the gratitude of the people that he encountered. They were moved by the gracious and heroic efforts made by this expedition. Despite formerly opposing the Federal Government, "hereafter and henceforth they truly believed that we were one family and under no circumstance would they be induced to lift a voice or hand against the North."<sup>54</sup>

The fever itself died with the coming of winter, as one correspondent put it, in the battle between the

Jacks: Yellow Jack and Jack Frost.<sup>55</sup> It would be decades before a cause for yellow fever was determined and a vaccine developed. The Army was a key element in that effort as well. In 1900, Maj. Walter Reed, Medical Corps, led an investigation board in Cuba to study tropical diseases, particularly yellow fever. His work was instrumental in confirming the vector for the disease through mosquitoes and in developing a vaccine. His chief nurse for the project was Lena Angevine Warner. During the 1878 epidemic, she had been discovered nearly dead, surrounded by the bodies of her six family members, all dead from yellow fever.<sup>56</sup>

Benner was buried in Vicksburg in the National Cemetery there. He was regarded a hero and given a hero's burial. Despite fears of the fever, the procession was long and colorful. There were fifteen different participating groups in the parade including three bands, dozens of carriages, a special escort of former Federal Army and Confederate officers, and others.<sup>57</sup> The gratitude of the Nation was such that Congress passed a bill for a pension specifically for Benner's wife and two daughters.<sup>58</sup> Mrs. Benner would in later years become the first post mistress of the Raven Park, Illinois, post office.

Surgeon General John M. Woodworth died on 12 March 1879. His death coincided with the passage of a bill to establish the National Board of Health. The Yellow Fever Commission noted that "his last and greatest effort, and the one which probably shortened his life, was his successful endeavor for the establishment of the National Board of Health, the bill for which passed the last Congress."<sup>59</sup> The success of the national relief boat was a catalyst to action and helped Woodworth in his advocacy for this bill. The commission made a resolution that in his death, "science has lost an eminent disciple, humanity an earnest laborer, and the United States Government an active, indefatigable, and zealous official."<sup>60</sup> They found that his work

"would nationalize sanitary science, and prevent the introduction and spread of contagious diseases."<sup>61</sup>

Frank W. Reilly became the sanitary inspector of Memphis and then the Mississippi Valley following the epidemic. He was later a member of the Illinois State Board of Health and long-time assistant commissioner of health for the city of Chicago. He was called one of the most notable characters in the annals of medicine and contributed greatly to the improvement and standardization of sanitation and medical care in Chicago, the state of Illinois, and across the Nation.<sup>62</sup>

Second Lt. Charles S. Hall took command of the expedition and saw it safely to its conclusion. He later served in various positions across the west on frontier duty from Fort Baynard, New Mexico Territory, to Fort Sill, Oklahoma Territory. He ended his career as a captain of cavalry in the Illinois Regiment following the Spanish-American War.<sup>63</sup>

George Mitchell, like Benner, had been a company commander during the Civil War, serving in the 5th New Jersey Infantry. The *Memphis Herald* recorded, Memphis has furnished its hero in connection with the God's-errand of the national relief-boat. Mr. George H. Mitchell, connected with the post office of this city, volunteered to take out the mail for points on the Mississippi ... He took out ten tons of mail matter, the largest that has ever left this city on any route ... That duty finished, he tendered his services as a nurse to Lieutenant Benner, and watched faithfully by his bedside to the last ... The distribution of that mail to the benighted denizens along the banks of the Mississippi, who had been virtually out of the world since the incipency of the plague, was the crowning glory of the mission of the relief boat.<sup>64</sup>

He would eventually become the director of the United States National Cemetery in Memphis. ■

## Notes

1. Molly Caldwell Crosby, *The American Plague: The Untold Story of Yellow Fever, the Epidemic That Shaped Our History* (New York: Berkley Books, 2006), 39.

2. "Fatal Work of the Fever," *New York Times* (website), 22 August 1878, 1, accessed 4 November 2016, <https://archive.nytimes.com/www.nytimes.com/ref/membercenter/nytarchive.html>.

3. Yellow Fever National Relief Commission (U.S.) Executive Committee, *Report of the Executive Committee of the Yellow Fever National Relief Commission, With Accompanying Reports of the Operations of the Relief Boat "John M. Chambers," Receipts, Disbursements, etc.* (Washington, DC: Printed by Order of the Committee, 1879), 6.

4. *Ibid.*

5. "The Scourge of the South," *New York Times* (website), 18 August 1878, 1, accessed 2 August 2016, <https://archive.nytimes.com/www.nytimes.com/ref/membercenter/nytarchive.html>.
6. J. L. Powers, *The Epidemic of 1878, in Mississippi: Report of the Yellow Fever Relief Work* (Jackson, MI: Clarion Steam Publishing House, 1879), 197, accessed 17 November 2017, <http://resource.nlm.nih.gov/65030600R>.
7. "More Deaths at Grenada," *New York Times* (website), 28 August 1878, 2, accessed 4 November 2016, <https://archive.nytimes.com/www.nytimes.com/ref/membercenter/nytarchive.html>.
8. J. M. Keating, *The Yellow Fever Epidemic of 1878, in Memphis, Tennessee* (Memphis, TN: Howard Association, 1879), 108.
9. *Ibid.*, 116.
10. "Local Paragraphs," *Memphis Daily Appeal* (website), 6 September 1878, 2, accessed 5 December 2019, <https://chroniclingamerica.loc.gov/lccn/sn83045160/1878-08-24/ed-1>.
11. Keating, *The Yellow Fever Epidemic of 1878*, 433.
12. "Southern Fever Terrors," *New York Times* (website), 30 August 1878, 1, accessed 2 November 2016, <https://archive.nytimes.com/www.nytimes.com/ref/membercenter/nytarchive.html>.
13. Yellow Fever National Relief Commission, *Report of the Executive Committee of the Yellow Fever National Relief Commission*, 7.
14. Charles S. Hall, *Report of the Expedition for the Relief of Yellow-Fever Sufferers on the Lower Mississippi* (Washington, DC: U.S. Government Printing Office, 1878), 19, accessed 28 March 2021, <https://archive.org/details/reportofexpediti01unit>.
15. *Ibid.*, 9.
16. Yellow Fever National Relief Commission, *Report of the Executive Committee of the Yellow Fever National Relief Commission*, 15.
17. *Ibid.*, 13–14.
18. *Ibid.*, 16.
19. *Ibid.*
20. "Measuring Worth Is a Complicated Question," *Measuringworth.com*, accessed 31 January 2022, <https://www.measuringworth.com>.
21. Crosby, *The American Plague*, 71.
22. Keating, *The Yellow Fever Epidemic of 1878*, 48.
23. Deanne Love Stephens Nuwer, "The 1878 Yellow Fever Epidemic in Mississippi, A Dissertation" (PhD diss., University of Southern Mississippi, 1996), 16, accessed 22 February 2022, [https://aquila.usm.edu/theses\\_dissertations/2360](https://aquila.usm.edu/theses_dissertations/2360).
24. *Ibid.*, 19.
25. "Fever and Quarantine," *New Orleans Daily Picayune* (website), 20 Aug 1878, 1, accessed 28 March 2021, <https://www.newspapers.com/image/27311198>.
26. Yellow Fever National Relief Commission, *Report of the Executive Committee of the Yellow Fever National Relief Commission*, 17.
27. *Ibid.*
28. Hall, *Report of the Expedition*, 5.
29. "Della Benner," *Proceedings and Debates of the Forty-sixth Congress*, 2nd sess., vol. 10, part 1 (Washington, DC: U.S. Government Printing Office, 1880), 570, accessed 31 January 2022, [https://www.govinfo.gov/app/collection/crecb/crecb/Volume%20010%20\(1880\)](https://www.govinfo.gov/app/collection/crecb/crecb/Volume%20010%20(1880)).
30. Hall, *Report of the Expedition*, 5.
31. George H. Mitchell, "Post Office Volunteer Aboard the National Relief Boat John M. Chambers" (unpublished journal, 7–11 October 1878), 1.
32. *Ibid.*, 6.
33. "The Relief Boat," *St. Louis Evening Post* (website), 4 October 1878, 1, accessed 2 November 2016, <https://www.newspapers.com/image/137798702/>.
34. Hall, *Report of the Expedition*, 6.
35. "The Relief Boat," *St. Louis Dispatch* (website), 4 October, 1878, 4, accessed 4 November 2016, <https://stltoday.newspapers.com/image/137798702>.
36. Hall, *Report of the Expedition*, 5.
37. "The River," *Daily Picayune* (website), 26 July 1884, 4, accessed 23 January 2021, <https://www.newspapers.com/image/28237159/?terms=Chambers>.
38. Hall, *Report of the Expedition*, 6.
39. *Ibid.*
40. Keating, *The Yellow Fever Epidemic of 1878*, 437.
41. *Ibid.*, 436.
42. Mitchell, "Post Office Volunteer," 5.
43. Hall, *Report of the Expedition*, 6.
44. Mitchell, "Post Office Volunteer," 4.
45. Frank Reilly, "Desolated by Death," *Chicago Times*, 12 October 1878, 2.
46. *Ibid.*
47. Mitchell, "Post Office Volunteer," 4.
48. *Ibid.*, 6.
49. Hall, *Report of the Expedition*, 9.
50. *Ibid.*, 17.
51. *Ibid.*, 10.
52. Headquarters, Thirteenth U. S. Infantry, General Orders Number 8, R. DeTrobriand, Colonel 13th Infantry Brevet Brigadier General, U. S. A. (Jackson Barracks, LA: 1 February 1879).
53. "Della Benner," 570.
54. Mitchell, "Post Office Volunteer," 7.
55. Nuwer, "The 1878 Yellow Fever Epidemic in Mississippi," 140.
56. Crosby, *The American Plague*, 3–4.
57. Hall, *Report of the Expedition*, 17.
58. "Della Benner," 570.
59. Yellow Fever National Relief Commission, *Report of the Executive Committee of the Yellow Fever National Relief Commission*, 25.
60. *Ibid.*
61. *Ibid.*
62. W. A. Evans, "In Memoriam of Frank W. Reilly, M.D.," in *Report of the Department of Health of the City of Chicago* (Chicago: Department of Health, City of Chicago, 18 December 1909), 2–4, accessed 14 January 2021, <https://books.google.com/books?id=Lz-tNAAAAMAAJ&printsec=frontcover#v=onepage&q&f=false>.
63. The Report of the Sixty-Second Annual Reunion of the Association of the Graduates of the United States Military Academy, 10 June 1931, 152–56, accessed 11 December 2020, [https://penelope.uchicago.edu/Thayer/E/Gazetteer/Places/America/United\\_States\\_Army/USMA/AOG\\_Reunions/62/Charles\\_Scott\\_Hall\\*.html](https://penelope.uchicago.edu/Thayer/E/Gazetteer/Places/America/United_States_Army/USMA/AOG_Reunions/62/Charles_Scott_Hall*.html).
64. Keating, *The Yellow Fever Epidemic of 1878*, 437.



# Protection of Civilians in Robust Peacekeeping Operations

## The Role of United Nations Special Operations Units

Maj. Josias Marcos de Resende Silva, Brazilian Army

**T**he United Nations (UN) faces a huge challenge today: implementing effective peacekeeping operations able to ensure the protection of civilians (POC) in complex and hostile environments. Since the end of the Cold War, the threat of conventional wars between national armed forces from different countries has decreased to a lower level. On the other hand, civil wars taking place among nationals in fragile states seem to be a tendency in contemporary conflicts. Because of these significant changes, the UN has endeavored to develop an efficient peace operation model as an attempt to stabilize countries devastated by war.

UN peacekeeping operations had to evolve from a passive and reactive mechanism, which sought to freeze or to paralyze a conflict, to a proactive actor at the conflict zone able to conduct the peace process in a broader way. In this context, the UN created wider or multidimensional peacekeeping operations combining military and civilian activities. Later, a police component would become the third pillar of these comprehensive missions. Nevertheless, the first generation of

multidimensional peacekeeping operations was implemented under the auspices of Chapter VI of the UN Charter. Thus, the success of those missions depended excessively on the goodwill of the warring parties.<sup>1</sup>

Lamentably, the first generation of multidimensional peacekeeping operations failed to deal with post-Cold War conflicts. In the mid-1990s, the UN Assistance Mission for Rwanda and the UN Protection Force were not capable of preventing atrocities such as genocide and ethnic cleansing against the civilian population in both Rwanda and Bosnia. As a result, the UN realized that it should be prepared to “engage in more ‘robust’ or ‘muscular’ peacekeeping” capable of effectively protecting civilians.<sup>2</sup>

Following a series of studies and debates, the UN 2005 World Summit approved the concept of responsibility to protect, which stresses that states have the primary responsibility to protect their civilians against grave violations of human rights. Nonetheless, when a state fails to do so, either by lack of capacity or willingness, the international community must take timely



A contingent of Senegalese blue helmets support the authorities in the protection of civilians 4 July 2019 during Operation Oryx in the Mopti region of central Mali. (Photo by Gema Cortes, UN Multidimensional Integrated Stabilization Mission in Mali)

and decisive action to prevent serious violations of human rights such as genocide, ethnic cleansing, war crimes, and crimes against humanity.<sup>3</sup>

A few years later, the UN capstone doctrine, *Peacekeeping Operations: Principles and Guidelines*, incorporated the concept of robust peacekeeping, allowing multidimensional operations to use all necessary force to protect civilians and fulfill their mandates.<sup>4</sup> Based on this new doctrine, in the last two decades, the United Nations Security Council (UNSC) has issued several resolutions under the auspices of Chapter VII of the UN Charter.<sup>5</sup>

However, despite the bold attitude adopted by the UNSC when issuing more robust resolutions, blue helmets deployed in hostile regions failed to use effective force to protect civilians from existing threats. In South Sudan, blue helmets refused to engage in combat on multiple occasions, allowing the massacre of civilians

and the invasion of UN bases by armed groups.<sup>6</sup> In the Central African Republic, over a hundred peacekeepers have been killed by rebel groups without an appropriate military response.<sup>7</sup> Moreover, in a more emblematic event that took place in the Democratic Republic of Congo, Goma was taken over by rebels with no reaction from the 1,500 blue helmets deployed in the Congolese city, damaging the mission's credibility.<sup>8</sup>

As an attempt to avoid further harm to its credibility, the UN decided to adopt special operations units within the structure of its most critical missions, sometimes integrated with intervention mechanisms. Thus, in 2013, a Tanzanian Special Forces company was deployed in the Democratic Republic of the Congo as part of the Force Intervention Brigade, complementing the UN Stabilization Mission in the Democratic Republic of the Congo's Special Forces Task Force.<sup>9</sup> In the UN Mission in South Sudan, the

Nepalese Special Forces company, also known as the High Readiness Company, was created in 2016 within the framework of the Regional Protection Force. Furthermore, the National Detached Force, composed of a Portuguese commando company, has become part of the UN Stabilization Mission in the Central African Republic since 2017.<sup>10</sup>

Given the high quality normally associated with these specialized troops, the recent adoption of special operations units within the structure of peacekeeping operations has created a significant expectation regarding the increase in UN missions capability of fulfilling their ambitious mandates and protecting civilians. In this context, how can special operations units best contribute to the protection of civilians in a robust peacekeeping operation?

Deployed by the UNSC since the last decade, UN special operations units are a significant innovation in peacekeeping history. In addition, the UN Department of Peace Operations (DPO) emphasizes that protection of civilians has become the most common standard for assessing the performance of UN peacekeeping.<sup>11</sup> Hence, understanding how these troops can enhance the protection of civilians emerges as a key factor for the success of robust peacekeeping operations.

## The United Nations Concept of Protection of Civilians

The protection of civilians is a complex issue with different meanings for the humanitarian, political, legal, and military components of a UN peacekeeping operation. Furthermore, since the protection of civilians is not a task that usually appears in national military doctrines, identifying protection operations has become a true challenge for most peacekeepers deployed all around the world. Thus, under the umbrella of protecting civilians, a varying range of activities has been tasked to the blue helmets according to conflicting interpretations.<sup>12</sup>

In compliance with the UN *Protection of Civilians* manual and within the framework of multidimensional peacekeeping missions, the DPO understands that the protection of civilians must be implemented based on a three-tiered approach: affording protection through political process, providing protection from physical violence, and establishing a protective environment.<sup>13</sup> Hence, the three-tiered approach has been created as

an attempt to provide missions leaders, troops, and police contributors an operationally focused and practical concept for protection of civilians to be applied in a peacekeeping environment.

The three tiers are equally important and must be conducted simultaneously, providing effective and lasting results regarding the POC in conflict environments. However, peacekeeping operations are generally the only international actor able to play a direct role in protecting civilians from physical violence.<sup>14</sup> For this reason, failure in addressing the second tier has the potential to harm the mission's overall legitimacy and credibility, both locally and globally, preventing the peacekeeping operation from successfully accomplishing the remaining two tiers.

In addition to the three tiers, the DPO explains that the POC must be implemented along four phases: prevention (no clear risk has been identified), preemption (existence of likely threats), response (attacks against civilians are imminent or occurring), and consolidation (threat has been mitigated or eliminated). Like the tiers, the POC phases are not mutually exclusive and can overlap.<sup>15</sup> As they require a secure environment and focus on the long-term solutions for the conflict, the activities performed under the prevention and consolidation phases are normally associated with the first and the third tiers of the POC concept. Conversely, the preemption and response phases aim at the short-term actions to reduce violence

**Maj. Josias Marcos de Resende Silva, Brazilian Army**, is a staff officer in the Brazilian Army Special Operations Command. He holds a master's degree in international relations and conflict resolution from the American Military University/American Public University System. During his career, Josias served with the 11th Infantry Mountain Battalion, the 1st Special Forces Battalion, the 1st Commando Battalion, and the Special Operations Training Center. He commanded the Command Company of the 14th Motorized Infantry Brigade. Josias has also been deployed in Ivory Coast and South Sudan. In the latter, as a United Nations Mission in South Sudan staff officer, he contributed to the planning and preparation for the deployment of Nepalese Special Forces company in Juba, also known as High Readiness Company.

## Table 1. MONUSCO (Military POC Tasks)

Military-Led Tasks	Military-Supported Tasks
<ul style="list-style-type: none"> <li>• Conduct foot patrol, particularly in high risk areas</li> <li>• Conduct mounted patrol, particularly in high risk areas</li> <li>• Ensure freedom of movement</li> <li>• Neutralize armed groups that pose imminent threat to civilians, either unilaterally or jointly with the FARDC*</li> <li>• Capture members of armed groups who pose imminent threat to civilians</li> <li>• Respond to threats and attacks on civilians</li> <li>• Provide expertise, advice, and training to the FARDC to strengthen their capacity, in particular through human rights training</li> <li>• Provide expertise, advice, and training to UN troops within MONUSCO</li> <li>• Provide security for UN personnel and facilities</li> </ul>	<ul style="list-style-type: none"> <li>• Collect information in support of the early warning mechanism, focusing on threats and attacks against civilians</li> <li>• Escort humanitarian convoys and personnel</li> <li>• Escort human rights patrols and personnel</li> <li>• Support initiatives to prevent violence against women</li> <li>• Support initiatives to prevent violence against children</li> <li>• Support the disarmament, demobilization, and reintegration process</li> </ul>

\*The Armed Forces of the Democratic Republic of the Congo  
(Table from UN Security Council, Resolution 2502, S/RES/2502, ¶ 29, 30, 35, 38, 42 [2019])

## Table 2. UNMISS (Military POC Tasks)

Military-Led Tasks	Military-Supported Tasks
<ul style="list-style-type: none"> <li>• Conduct active patrolling</li> <li>• Ensure freedom of movement</li> <li>• Control major lines of communication and transport within Juba</li> <li>• Engage any actor who poses imminent threat to UN protection of civilian sites, UN personnel and facilities, international and humanitarian actors, and civilians in general</li> <li>• Respond to threats and attacks on civilians</li> <li>• Provide security for UN personnel and facilities</li> <li>• Secure protection of civilian sites and refugee camps</li> <li>• Secure key civilian facilities and infrastructure, including the Juba International Airport</li> </ul>	<ul style="list-style-type: none"> <li>• Collect information in support of the early warning mechanism, focusing on threats and attacks against civilians</li> <li>• Escort humanitarian convoys and personnel</li> <li>• Escort human rights patrols and personnel</li> <li>• Support initiatives to prevent violence against women</li> <li>• Support initiatives to prevent violence against children</li> </ul>

(Table from UN Security Council, Resolution 225, S/RES/225, ¶ 7, 10 [2019])

against civilians, which is an essential condition for creating a secure environment. Thus, activities conducted under these phases generally correspond to the second tier of the POC concept.

Therefore, in a peacekeeping operation, the success in the protection of civilians highly depends on the capacity of the military contingent in reducing violence and creating a secure environment.<sup>16</sup> Once the minimum degree of stability is established, the political and humanitarian actors take the lead, engaging with national authorities to address the roots of the conflict and to achieve a long-term solution.

### Military Protection Tasks in Robust Peacekeeping Operations

To determine which POC activities are appropriate for UN special operations units, it is first necessary to identify the main POC tasks assigned to the military components of current UN robust peacekeeping operations. In this sense, this research considered all military protection activities described in the UNSC resolutions concerning the six ongoing multidimensional peacekeeping operations that are based on Chapter VII of the UN Charter:

- the UN Stabilization Mission in the Democratic Republic of the Congo (MONUSCO),

**Table 3. MINUSCA (Military POC Tasks)**

Military-Led Tasks	Military-Supported Tasks
<ul style="list-style-type: none"> <li>• Conduct active patrolling in high risk areas</li> <li>• Ensure freedom of movement</li> <li>• Respond to threats and attacks on civilians</li> <li>• Capture weapons and ammunitions from armed groups who represent an imminent threat to civilians or to the stability of the state</li> <li>• Provide security for UN personnel and facilities</li> </ul>	<ul style="list-style-type: none"> <li>• Collect information in support of the early warning mechanism, focusing on threats and attacks against civilians</li> <li>• Escort humanitarian convoys and personnel</li> <li>• Escort human rights patrols and personnel</li> <li>• Support initiatives to prevent violence against women</li> <li>• Support initiatives to prevent violence against children</li> <li>• Support the disarmament, demobilization, and reintegration process</li> </ul>

(Table from UN Security Council, Resolution 2499, S/RES/2499, ¶ 7, 32, 45, 47 [2019])

**Table 4. MINUSMA (Military POC Tasks)**

Military-Led Tasks	Military-Supported Tasks
<ul style="list-style-type: none"> <li>• Ensure freedom of movement</li> <li>• Engage in direct operations against serious and credible threats</li> <li>• Respond to threats and attacks on civilians</li> <li>• Establish surveillance and monitoring on possible threats to civilians</li> <li>• Provide security for UN personnel and facilities</li> <li>• Provide training and relevant equipment to the MDSF (Malian Defense and Security Forces)</li> </ul>	<ul style="list-style-type: none"> <li>• Collect information in support of the early warning mechanism, focusing on threats and attacks against civilians</li> <li>• Escort humanitarian convoys and personnel</li> <li>• Escort human rights patrols and personnel</li> <li>• Support initiatives to prevent violence against women</li> <li>• Support initiatives to prevent violence against children</li> <li>• Support the disarmament, demobilization, and reintegration process</li> <li>• Support the implementation of quick impact projects</li> </ul>

(Table from UN Security Council, Resolution 2480, S/RES/2480, ¶ 23, 28, 32, 48 [2019])

- ◆ the UN Mission in South Sudan (UNMISS),
- ◆ the UN Stabilization Mission in the Central African Republic (MINUSCA),
- ◆ the UN Multidimensional Integrated Stabilization Mission in Mali (MINUSMA),
- ◆ the UN Interim Security Force for Abyei (UNISFA), and
- ◆ the African Union-United Nations Hybrid Operation in Darfur (UNAMID).

Although the African Union-United Nations Hybrid Operation in Darfur is not an exclusive UN operation, this research also considered it for data collection because the mission conserves most of the characteristics found in a UN robust peacekeeping operation.

In tables 1–6 (on pages 50–52), the main POC tasks are listed in two different columns. The first column lists all military protection tasks in which the military

component of a UN peacekeeping operation takes prominence. Normally, most of these activities are related to the second tier of the POC concept and become more relevant during the preemption/response phases. On the other hand, the second column lists POC tasks in which the military force participates as a support element to allow other peacekeeping components, UN agencies, and humanitarian actors to fulfill their purpose. These activities are commonly associated with the first and third tiers of the POC concept and grow in importance during the prevention/consolidation phases. It is also important to note that the UNSC resolutions enumerate other activities under the first and third tiers mostly concerning political, legal, and humanitarian issues. However, they were not taken into consideration because either the military component does not participate or contributes very little to their fulfillment.

### Table 5. UNISFA (Military POC Tasks)

Military-Led Tasks	Military-Supported Tasks
<ul style="list-style-type: none"> <li>• Ensure freedom of movement</li> <li>• Provide security for UN personnel and facilities</li> <li>• Secure the Abyei area</li> </ul>	<ul style="list-style-type: none"> <li>• Escort humanitarian convoys and personnel</li> <li>• Escort human rights patrols and personnel</li> </ul>

(Table from UN Security Council, Resolution 1990, S/RES/1990, ¶ 2, 3, 10 [2011])

### Table 6. UNAMID (Military POC Tasks)

Military-Led Tasks	Military-Supported Tasks
<ul style="list-style-type: none"> <li>• Conduct active patrolling in high risk areas</li> <li>• Ensure freedom of movement</li> <li>• Respond to threats and attacks on civilians</li> <li>• Provide security for Hybrid African Union-UN personnel and facilities</li> <li>• Secure protection of civilian sites</li> </ul>	<ul style="list-style-type: none"> <li>• Collect information in support of the early warning mechanism, focusing on threats and attacks against civilians</li> <li>• Escort humanitarian convoys and personnel</li> <li>• Escort human rights patrols and personnel</li> <li>• Support initiatives to prevent violence against women</li> <li>• Support initiatives to prevent violence against children</li> <li>• Support the disarmament, demobilization, and reintegration process</li> <li>• Support for mine action</li> </ul>

(Table from UN Security Council, Resolution 2363, S/RES/2363, ¶ 15, 30 [2017])

The six tables describe the POC activities for the military component in each of those robust peacekeeping operations. The amount of POC tasks performed by the military component varies in accordance with a series of factors involving the available troops, the mission, and the operational environment. Nevertheless, most of the identified POC tasks are coincident in two or more UN missions, which means that the UNSC follows a similar pattern to address the protection of civilian activities in multidimensional peacekeeping operations under Chapter VII of the UN Charter. In summary, the military POC tasks can be condensed and organized (see table 7, page 53).

Table 7 depicts the intermediate product of this analysis by organizing all current military POC tasks into two different categories: military-led tasks and military-supported tasks. Under normal circumstances, the police and the civilian components may take the lead in some “military-led” tasks such as “secure UN POC sites and refugee camps” and “provide security for UN personnel and facilities.” Nonetheless, in situations

of crises, the military component is the ultimate responsible for leading all those tasks.

## The Role of United Nations Special Operations Units

The Department of Peace Operations does not clearly distinguish special operations forces from Special Forces since the UN does not want to override national doctrines. In fact, both terms are often used as synonyms in the *United Nations Peacekeeping Mission Military Special Forces Manual*. For this reason, this article uses the term special operations forces (SOF), which is broader and covers different national definitions of Special Forces.

According to the *United Nations Peacekeeping Missions Military Special Forces Manual*, “Special Operations are military activities conducted by specifically designated, organized, trained and equipped forces, manned with selected personnel using unconventional tactics, techniques, and courses of action.”<sup>17</sup> Moreover, SOF differs from conventional forces due to

**Table 7. Military POC Tasks**

Categories	Tasks
Military-Led Tasks	Neutralize actors who pose imminent threat to civilians Capture weapons and members of armed groups who pose imminent threat to civilians Respond to threats or attacks on civilians, including UN personnel and international/UN associates/humanitarian actors Establish surveillance and monitoring on possible threats to civilians Conduct active foot and mounted patrol, particularly in high risk areas Ensure freedom of movement by controlling the mission’s major lines of communications and transport Provide security for UN personnel and facilities Secure UN protection of civilian sites and refugee camps Secure key civilian facilities and infrastructure Provide expertise, advice, and training to local defense/security forces Provide expertise, advice, and training to UN troops
Military-Supported Tasks	Collect information in support of the early warning mechanism, focusing on threats and attacks against civilians Escort humanitarian convoys and personnel Escort human rights patrols and personnel Support initiatives to prevent violence against women Support initiatives to prevent violence against women Support the disarmament, demobilization, and reintegration process Support for mine action Support the implementation of quick impact projects

(Table by author)

the use of small teams, their independence from friendly support, their high situational consciousness, and the political repercussion of their actions.

In the context of peacekeeping, UN SOF can contribute to the achievement of the UN operation mandate during the prevention, preemption, response, and consolidation phases.<sup>18</sup> Throughout these phases, UN SOF must perform three principal missions: Special Tasks, Special Reconnaissance, and Military Assistance.<sup>19</sup>

**Special tasks.** Special Tasks are precise offensive operations, conducted with minimum collateral damage, limited in scope and time in order to acquire, disrupt, recover, neutralize, or disable designated high-tech value and high-payoff objectives. In addition to that, “Special Tasks are focused on specific, well-defined objectives of strategic and operational significance or the conduct of decisive tactical operations.”<sup>20</sup>

When conducting Special Tasks, SOF must obtain “relative superiority” over their enemies, which is the

association of the six principles of special operations: simplicity, security, repetition, surprise, speed, and purpose. Hence, by creating simple and concealed plans, realistically and extensively rehearsing those plans, and executing them with speed and purpose, SOF are able to create a decisive temporary advantage over a much stronger or well-defended enemy force.<sup>21</sup>

Considering the military POC tasks (see table 7), Special Tasks will normally encompass, with or without the support from conventional forces, “neutralize actors who pose imminent threat to civilians”; “capture weapons and members of armed groups who pose imminent threat to civilians”; and “respond to threats or attacks on civilians, including UN personnel and international/UN associates/humanitarian actors.” Nonetheless, before deploying SOF to perform the aforementioned tasks, it is essential to ensure that these missions are above the capability of the conventional troops available, they involve political risks and/or extreme danger,

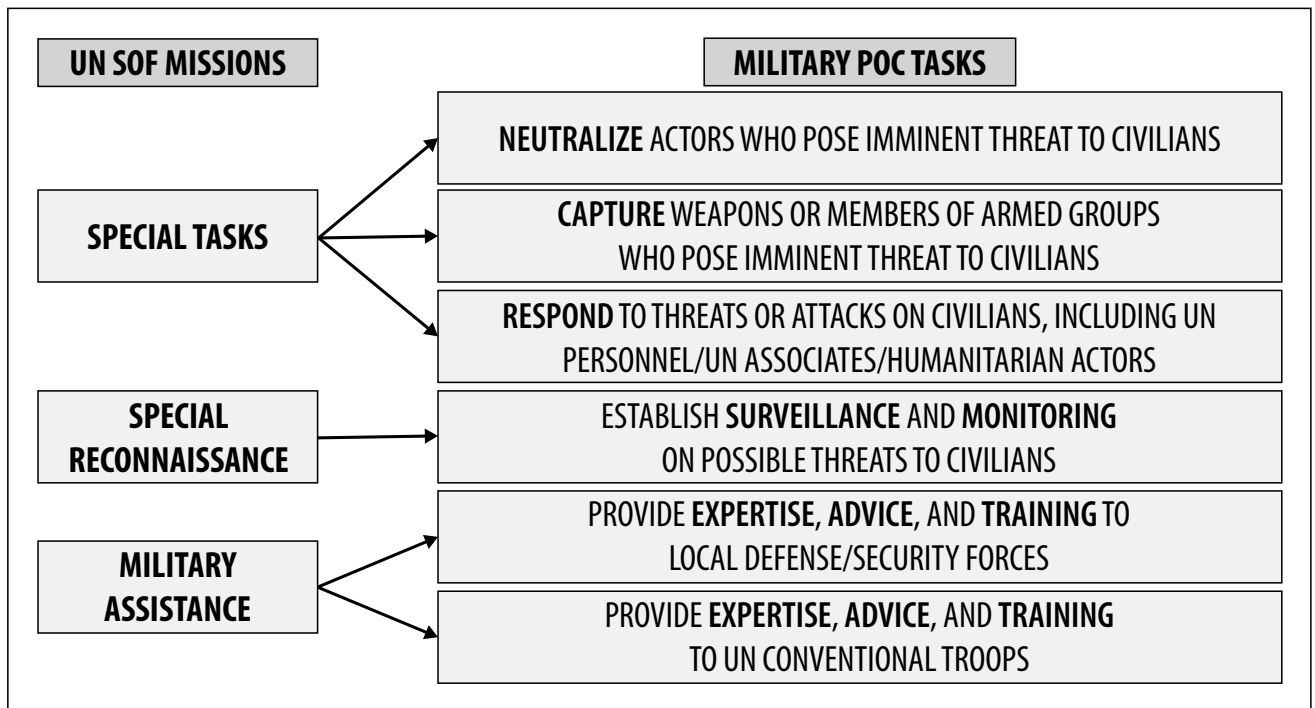

(Figure by author)

## Figure. UN Special Operations POC Tasks

and they will have an impact on the long-term stabilization process. Given the actual or imminent presence of threats, Special Tasks occur during the preemption and response phases.

**Special reconnaissance.** As a second principal SOF mission, “Special Reconnaissance provides specific, well-defined, and time-sensitive information in support of the Force intelligence collection process.”<sup>22</sup> Also, UN special operations units conduct Special Reconnaissance to collect or verify information of strategic or operational significance. Usually, Special Reconnaissance consists of long-range reconnaissance and surveillance techniques of targets located in a hostile, denied, or sensitive territory.

When conducting Special Reconnaissance, special operations units observe the principle of “certain access,” which is the ability to rapidly and securely insert and extract from a hostile area of operations, normally undetected, enabling operations in areas where or when conventional operations are not possible.<sup>23</sup>

Taking into consideration the military POC tasks (table 7), SOF are suitable for conducting Special Reconnaissance to “establish surveillance and monitoring on possible threats to civilians.” In this context,

especially during the preemption and response phases, special operations units are able to produce force-level intelligence, accessing sensitive and/or hostile areas not recommended for conventional troops.

**Military assistance.** Finally, military assistance is the third principal mission for UN SOF. According to the UN special operations doctrine, “the range of military assistance includes, but is not limited to, engagement with local, regional, and national leadership or organizations, and capability building of friendly security forces.”<sup>24</sup> The main activities under the umbrella of the military assistance are training, advising, and mentoring. Thus, in the context of military assistance operations, UN SOF can be tasked to provide training to the armed forces of a host country; assist the UN mission in training conventional blue helmets; and mentor local units through direction and guidance to plan, prepare, and conduct operations.

There are two main types of operations associated with military assistance: unconventional warfare and integrated operations. SOF normally conduct unconventional warfare when operating and exploiting the capabilities of foreign military and paramilitary forces. Concerning integrated operations, SOF have the ability to address the different types of threats by integrating



**Table 8. Deaths Due to Armed Conflict**

	Eastern Congo (SFTF)		Juba (HRC)		CAR (FND)	
	Year	Deaths	Year	Deaths	Year	Deaths
Unit creation and/or initial deployment	2013	1321	2016	390	2017	1795
Second year of deployment	2014	89	2017	0	2018	585
Third year of deployment	2015	10	2018	10	2019	476

(Table by author; based on data from the Uppsala Conflict Dataprogram)

elements of national power and operating with other military forces and nonmilitary agencies.<sup>25</sup>

Compared to the military POC tasks, military assistance corresponds to “provide expertise, advice, and training to local defense/security forces” and to “provide expertise, advice, and training to UN troops.” Hence, the application of the military assistance within the framework of the protection of civilians enhances the quality and effectiveness of local legal forces and other UN troops in the mission. Unlike Special Tasks and Special Reconnaissance, which are normally conducted during the preemption and response phases, the military assistance usually takes place during the prevention and consolidation phases, contributing to the long-term stabilization process. By enabling a significant number of local and UN troops to protect civilians and achieve their objectives, the UN special operations unit works as a true force multiplier in a UN peacekeeping operation.

The figure (on page 54) explains how SOF missions are related to military POC tasks. It also proposes the military POC tasks more suitable for special operations units to perform in a robust peacekeeping operation. Furthermore, it is important to consider that when conducting the six activities listed in the figure, special operations units are expected to improve the entire military performance in a peacekeeping operation. This is because Special Tasks aim at obtaining a deterrent effect on adversarial forces, Special Reconnaissance produces accurate intelligence in a hostile or denied environment, and military assistance improves the UN troops and/or

local defense/security forces quality and morale.

Incipient in the context of peace operations, UN SOF units have already delivered encouraging results where they have been deployed. Notable among their main achievements are the victories over the armed groups *Mouvement du 23 Mars* and *Forces Démocratiques Alliées* (Allied Democratic Forces) in the eastern region of the Democratic Republic of the Congo, as well as over the rebel Central African Republic

groups Union for Peace in the Central African Republic and Popular Front for the Rebirth of Central African Republic.<sup>26</sup> Furthermore, shortly after the implementation of UN SOF units, deaths as a result of armed conflicts decreased markedly in their respective areas of responsibility, which correspond to the Eastern Congo for the Special Forces Task Force, Juba for the High Readiness Company, and the Central African Republic for the National Detached Force. This initial impact, which is demonstrated in table 8, helps to increase local people’s hope and confidence in the peace process.

Due to the complexity of contemporary conflicts, it is premature to attribute the reduction of deaths exclusively to the deployment of UN SOF units in conflict zones. However, especially in Eastern Congo and Juba, where the impact of these units can be better measured because they operate in a more restricted geographic area, this decrease indicates that the use of UN SOF units emerges as a viable tool in the future of robust UN peacekeeping operations.

## Conclusion

UN robust peacekeeping operations use a three-tiered approach to protect of civilians in hostile environments. While the first and third tiers aim at creating long-term conditions for the safety of local populations, the purpose of the second tier is to immediately protect civilians against physical violence.

When analyzing the UNSC resolutions for the six ongoing multidimensional peacekeeping operations under Chapter VII of the UN Charter, it is possible to determine

the core military tasks related to the protection of civilians in hostile environments. These POC activities are organized into two different categories: military-led tasks and military-supported tasks. Most military-led tasks are linked to the second tier of the UN POC concept. Thus, the military component of a UN peacekeeping operation is a key actor to reduce violence in the short-term, which is essential to create a stable environment.

There are six specific military POC tasks that are compatible with UN special operations doctrinal missions and work as force multipliers to enhance the performance of the entire military component in a robust peacekeeping environment. These tasks are neutralization of actors who pose imminent threat to civilians; capture of weapons or members of armed groups who pose imminent threat to civilians; response to threats or attacks on civilians, including UN personnel and international/UN associates/humanitarian actors; establishment of surveillance and monitoring on possible threats to civilians; provision of expertise, advice, and training to

local defense/security forces; and provision of expertise, advice, and training to UN troops. Moreover, by conducting these tasks, UN special operations units contribute to peacekeeping operations from the early stages to peace building, covering all phases of a POC mandate: prevention, preemption, response, and consolidation.

The relevance of UN SOF units already deployed in robust peacekeeping operations is validated by the great decrease in the number of deaths due to armed conflict in their respective areas of responsibility, which is one of the most important POC indicators.

This study does not exhaust the knowledge on the use of special operations units in robust peacekeeping operations. On the contrary, the deployment of these specialized units is an innovation in UN history and their impact on the protection of civilians is incipient. Therefore, future research on peacekeeping missions under Chapter VII of the UN Charter, particularly those who received special operations units, would efficiently complement and improve this research. ■

---

## Notes

1. Kai Kenkel, "Five Generations of Peace Operations: From the 'Thin Blue Line' to 'Painting a Country Blue,'" *Revista Brasileira de Política Internacional* 56, no. 1 (2013): 129, accessed 8 November 2021, <https://www.scielo.br/j/rbpi/a/mTGNK7hRXJBmjvmQmdQCZrh/>.

2. David Ucko and Mats Berdal, "The Use of Force in UN Peacekeeping Operations: Problems and Prospects," *The Rusi Journal* 160, no. 1 (2015): 7, <https://doi.org/10.1080/03071847.2015.1016718>.

3. Nicholas Wheeler and Alex Bellamy, "Humanitarian Intervention in World Politics," in *The Globalization of World Politics: An Introduction to International Relations*, ed. John Baylis, Steve Smith, and Patricia Owens, 6th ed. (Oxford: Oxford University Press, 2014), 486.

4. United Nations (UN), *United Nations Peacekeeping Operations: Principles and Guidelines* (New York: Department of Peace Operations, 2008).

5. Cedric de Coning, "Peace Enforcement in Africa: Doctrinal Distinctions between the African Union and the United Nations," *Contemporary Security Policy* 38, no. 1 (2017): 148, <https://doi.org/10.1080/13523260.2017.1283108>.

6. Scott Lyons, "New Robust Peacekeeping," *Proceedings of the ASIL [American Society of International Law] Annual Meeting* 112 (2018): 110, accessed 8 November 2021, <https://www.cambridge.org/core/journals/proceedings-of-the-asil-annual-meeting/article/new-robust-peacekeeping/D47A508D30E66129E9297C929D0018>.

7. "United Nations Multidimensional Integrated Stabilization Mission in the Central African Republic [MINUSCA]," UN MINUSCA, accessed 23 November 2021, <https://minusca.unmissions.org/en>.

8. Sudarsan Raghavan, "In Volatile Congo, a New UN Force with Teeth," *The Washington Post* (website), 2 November 2013,

accessed 8 November 2021, [https://www.washingtonpost.com/world/africa/in-volatile-congo-a-new-un-force-with-teeth/2013/11/01/0cda650c-423f-11e3-b028-de922d7a3f47\\_story.html](https://www.washingtonpost.com/world/africa/in-volatile-congo-a-new-un-force-with-teeth/2013/11/01/0cda650c-423f-11e3-b028-de922d7a3f47_story.html).

9. UN, *Standard Operations Procedures: Special Forces Task Force Cell* (Goma: United Nations Organization Stabilization Mission in the Democratic Republic of the Congo Force Headquarters, 2015), 3.

10. Musa Paulino, "Missão na República Centro-Africana: 1ª Força Nacional Destacada," *Revista Mama Sume*, no. 80 (2017): 18, accessed 8 November 2021, <http://associacao.comandos.pt/associacao-comandos/publicacoes/revista-mama-sume/revista-mama-sume-no-80/>.

11. UN, *Protection of Civilians in Peacekeeping Operations* (New York: Department of Peace Operations, 2020).

12. UN, *Protection of Civilians* (New York: Department of Peace Operations, 2012), 18.

13. *Ibid.*, 65.

14. *Ibid.*, 70.

15. *Ibid.*, 12.

16. Mary Kaldor, "Inconclusive Wars: Is Clausewitz Still Relevant in these Global Times?," *Global Policy* 1, no. 3 (2010): 280, <https://doi.org/10.1111/j.1758-5899.2010.00041.x>.

17. UN, *United Nations Peacekeeping Missions Military Special Forces Manual* (New York: Department of Peace Operations, January 2015), 9, accessed 23 November 2021, <http://dag.un.org/handle/11176/89590>.

18. UN, *United Nations Peacekeeping Missions Military Special Forces Manual*, 12.

19. *Ibid.*

20. *Ibid.*, 18.

21. William McRaven, "The Theory of Special Operations" (master's thesis, Naval Postgraduate School, 1993), 11–37, accessed 8 November 2021, <https://www.afsoc.af.mil/Portals/86/documents/history/AFD-051228-021.pdf>.

22. UN, *United Nations Peacekeeping Missions Military Special Forces Manual*, 17.

23. Robert Spulak Jr., "A Theory of Special Operations," *Military Technology* 33, Special Issue (2009): 25, accessed 23 November 2021, [http://www.ifpa.org/confnrcNorkshop/confnrcN-workshpPages/nssc\\_march2010/PDF3.pdf](http://www.ifpa.org/confnrcNorkshop/confnrcN-workshpPages/nssc_march2010/PDF3.pdf).

24. UN, *United Nations Peacekeeping Missions Military Special Forces Manual*, 19.

25. Spulak, "A Theory of Special Operations," 26.

26. Josias Silva, "Unidades de Operações de Paz: uma Solução Viável para o Uso da Força no contexto das Operações de Paz?," *Observatório Militar da Praia Vermelha*, 30 June 2020, accessed 8 November 2021, <http://ompv.eceme.eb.mil.br/missao-de-paz/operacao-de-manutencao-da-paz/280-unidades-de-operacoes-especiais-da-onu-uma-solucao-viavel-para-o-uso-da-forca-no-contexto-das-missoes-de-paz>.

## New from AUP Research and Books

To view the complete listing of publications from Army University Press Research and Books, visit <https://www.armyupress.army.mil/Books/>.

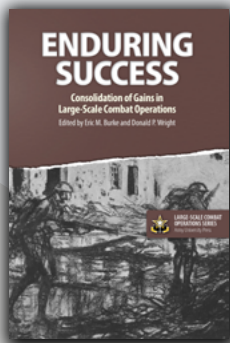

### Enduring Success Consolidation of Gains in Large-Scale Combat Operations

Edited by Eric M. Burke and Donald P. Wright

The twelfth volume of the LSCO series, *Enduring Success*, offers a collection of historical case studies, ranging from 1898 to 2003, concerning the challenges of consolidating gains in the spatial or temporal wake of large-scale combat operations. Its contributors recount how senior military commanders historically confronted the problem of securing tactical and operational successes behind the front lines and linking those successes to higher-level objectives established by political leaders. As the case studies vividly illustrate, those who either ignore or fail in consolidation of gains efforts risk winning the battle but losing the war.

### Nisei Spirit The Cultural Identity of the 442nd RCT

By David F. Bonner

The majority of the 442nd Regimental Combat Team during World War II consisted of second-generation Japanese Americans, or Nisei. An enduring sense of duty instilled by their families and a tight-knit network of Nikkei communities in the United States shaped the combat motivations of the Nisei soldiers. Author David Bonner examines this strong cultural identity, paired with the task cohesion and primary group cohesion theories, as it forms a framework for achieving a better understanding of small-unit effectiveness. This is a story of unparalleled fortitude in the face of adversity, ranging from prejudice in the rear to seemingly overwhelming odds on the front line.

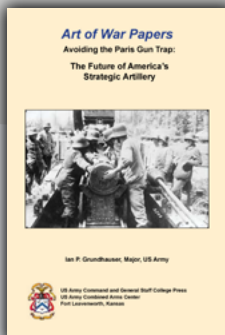
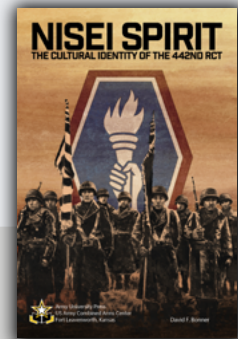

### Avoiding the Paris Gun Trap The Future of America's Strategic Artillery

By Ian P. Grundhauser

In an attempt to end the stalemate on the western front during World War I, German scientists and engineers created a supergun capable of firing a 233-pound projectile over seventy-five miles to bombard the citizens of Paris. These weapons, The Paris Guns, possessed the potential to achieve an exponential military advantage for the German military. The Germans' folly became clear as they developed a weapon without first considering its ability to achieve the effects they desired. Today, the U.S. Army seeks to develop superguns capable of exponentially increased range, the strategic long-range cannons. The U.S. Army has defined a role for these weapons in deterring in competition, and penetrating and dis-integrating antiaccess and area denial networks in armed conflict. This study examines the history and effects of The Paris Guns at the strategic level.

# The Strategic Competition for Partnership

## Inside Views from the Backbench: An Aide's Observations of Senior Leader Engagements

Capt. Sarah Melville, U.S. Army

In October 2018, in Gaborone, Botswana, over thirty key African leaders and defense attachés gathered in a small room for an icebreaker. The term “icebreaker” did not translate to most in the room and seemed nothing more than Western colloquialism. Together, huddled by country, this was the start of a U.S. Army Africa (USARAF) Regional Leader’s Seminar.<sup>1</sup> The USARAF deputy commanding general (DCG) opened the gathering with a warm welcome and introduction for the discussions to come. Establishing a personal connection with his African counterparts would be critical if the dialogue the next day was to be fruitful. Over the course of the evening, the metaphorical ice melted.

The Regional Leader’s Seminar aimed to engage with key military leaders and discuss ways they and their respective militaries can come together to increase security, stability, and the overall peace within a region and the continent. To discuss such wide-ranging

topics is no simple task, with leaders carrying the historical memory of generations of tribal, ethnic, or colonial conflict often against others around the table. Furthermore, with the U.S. Army as the cohost and facilitator, a diplomatic and nuanced tone is necessary to mitigate perceptions of neocolonialism.

The following article identifies key principles learned through analyzing over seventy engagements between a DCG and leaders such as chiefs of defense, land component commanders, UN commanders, and ambassadors, as well as DCG engagements as a co-exercise director for major military exercises involving well over half the countries in Africa. From this analysis, many patterns emerge for how to successfully build, maintain, and expand strategic relationships into sustainable partnerships. From the vantage point of an aide-de-camp, the following insights delve into the inner workings of a senior leader’s engagement preparation, execution, and follow-up.



Members of the Ethiopian National Defense Force and the U.S. Army salute 16 July 2019 during their countries' national anthems at the opening ceremony for the field training exercise portion of Justified Accord 2019 at the Hurso Training Center near Dire Dawa, Ethiopia. Justified Accord is an annual combined, joint exercise designed to strengthen partnerships, increase interoperability, and enhance the capability and capacity of international participants to promote regional security and support peacekeeping operations for the African Union Mission in Somalia. (Photo by Sgt. Aubry Buzek, U.S. Army)

The importance of engaging our partners successfully is critical within strategic competition. As Chief of Staff of the Army General James McConville says, We never want to fight alone. We will always strive to fight in combined formations with our allies and partners who share our values and interests. Our allies and partners provide us a unique and powerful advantage over our adversaries.<sup>2</sup>

To strengthen this advantage and build strategic partnerships, transparency and an outward sense of humility, particularly in addressing complex problems, is key. Each engagement serves as more than a meeting; it is an opportunity to foster a relationship and appreciate and encourage the diversity of experiences each partner provides. It is also an opportunity

to exemplify the professionalism and principles that characterize the U.S. military. Persistency in building partners across all sectors of government and the ability to capture and amplify the effects of a senior leader's engagements throughout an organization further increase the ability to solidify our comparative advantage in strategic partnerships. Relationship building at a strategic level not only affects alliances between nations but also filters down to units on the ground, which can further enhance the resourcefulness, creativity, and adaptability of our forces.

### **Partnerships Grown Out of Humility**

An important leadership trait in effective engagement is humility. Humility is a state of mind; it helps offset historical antagonisms and fosters a receptive



Maj. Gen. Roger Cloutier (right), U.S. Army Africa commanding general, meets with Senegal Brig. Gen. Cheikh Wade, chief of army staff, for a bilateral engagement during African Land Forces Summit (ALFS) at Gaborone International Convention Center, Gaborone, Botswana, 27 June 2019. ALFS is a four-day seminar that brings together land forces chiefs from across Africa to discuss topics of common interest. (Photo by Spc. Angelica Gardner, U.S. Army)

environment to build new partnerships from a mutually beneficial blank slate.

The DCG treated everyone he met, from a Dutch corporal to the highest-ranking officer in Rwanda, with respect and showed he valued their time and willingness to meet with him. Instead of discussing the accolades of the U.S. Army and the benefits of our partnered training, he instead listened to the successes and challenges faced by his partners and asked how the U.S. Army could help make *their own initiatives* more effective. By turning the conversation around to show an interest in building a partner's capacity, he set the tone to establish a mutually beneficial relationship. He frequently spent more time listening than talking and was genuine in his desire for partnership and friendship.

The DCG approached his engagements with a clear mission—he was not looking to sell a product or

advertise the U.S. Army. Rather, he wanted to build relationships that contributed to lasting partnerships. He was not dismissive or armed with a hidden agenda; both can quickly stifle a relationship before it even begins.

Conducting a meaningful senior leader engagement with tangible outcomes requires finesse and interpersonal skills, the ability to judge a situation quickly, and a respect for other cultures. To show this respect, one must be conscious of how he or she communicates within his or her own military and recognize that the same methods may not always be conducive with international partners. Particularly in first impressions, words can set the precedent. For example, the DCG once met with an African senior leader and began discussing the role of USARAF within its combatant command, U.S. Africa Command (USAFRICOM), something he commonly did to better articulate how

the organization fits within the U.S. military. However, the partner leader immediately cut him off and asked whom he commanded in Africa. The question startled the DCG. Concerned about harming the relationship, he quickly translated the U.S. military term further, explaining it as an organizational construct and not a literal command of Africa.

Organizational phrases and slogans do not always mean the same things to our partners as they do to us. Another example is “African solutions for African problems,” which to U.S. Army leaders holds a positive connotation and stresses the goal of building our partners’ capacities so they may be better able to counter regional and continent-wide challenges independently. However, in a discussion with around two dozen senior African leaders following a multinational exercise, the partner cohost bluntly stated, many problems affecting Africa are not “African” problems but global ones.

While a leader may not understand all the intricacies of their partner’s history and culture, one leveling characteristic to help alleviate unintentional tension from such situations is genuine humility.

## Appreciating Diversity of Experience

A senior leader represents his or her military and country; his or her engagements are not merely individual but help to build allies amongst nations. Equally important to understanding a senior leader’s individual role and responsibility is recognizing his or her own biases and perceptions that may shape how he or she engages. A leader who appreciates the diversity of experiences a partner offers can increase the collaboration and reciprocated knowledge between their forces instead of underappreciating the value the partnership can mean for both sides.

Many misconceptions exist when labeling a country “third world” or “developing”; these labels do not equate to the abilities or intellectual sophistication of a country’s people. In our travels, it was common to come across a partnered service member who spoke six or more distinct languages, including English. Our exercises were run in English; leaders from throughout Africa would regularly converse and brief in a language that was not their first or even third language learned. Not only did many of our partners have impressive language capabilities, but they also had military training and combat

experience vastly different and often more challenging than that of most American service members.

For example, an officer who grew up as a refugee in Uganda started his military experience in the Ugandan National Resistance Army. When he left Uganda, he went from one conflict to another and began fighting against the genocidaires in Rwanda. Determined to save his fellow countrymen, he walked across the country with little food and water to help end the genocide. This background shaped his passion for peacekeeping operations. He subsequently fought in Darfur out of a sense of duty to prevent what happened in Rwanda from happening in another country. He never received any branch-specific training but instead grew up training as a rebel. He is now a general officer with a sincere desire to help professionalize his force. He champions the development of an NCO corps and incorporating more women in the military, particularly in peacekeeping operations. His expertise in survival training and peacekeeping operations greatly varies from that of our own military members, yet many of his goals for professionalization are the same. Just as the U.S. military values diversity as a strength within its ranks, recognizing the diversity of experiences with our allies can lead to more mutually beneficial partnerships. The following are a couple of examples of partnerships grown out of diversity.

Many African countries provide the environment for our partners to excel and teach U.S. forces how to become more resilient, creative, and tenacious. U.S. soldiers who conducted field training during USARAF exercises with their partners in Ethiopia and Rwanda learned just as much from their partners if not more than what our partners learned from them. From survival techniques to infantry tactics, our partners excelled and demonstrated to our soldiers that a lack of resources does not equate to poor

**Capt. Sarah Melville, U.S. Army**, holds a Bachelor of Science degree from the U.S. Military Academy at West Point and a Master of Science degree from the University of Oxford. She previously served as an aide-de-camp for two U.S. Army Africa/Southern European Task Force deputy commanding generals and as an executive officer to the deputy commanding general. During her time at U.S. Army Africa, she participated in senior leader engagements throughout Africa, Europe, and the United States.

tactical skills. While soldiering requires basic resources, it was interesting to observe our heavily laden U.S. forces trying to keep pace with their counterparts racing through the hills of the training area and to see our reliance on radios compared to the dependence on verbal communications and hand signals by our partners.

In one exercise, our partners taught U.S. engineers how to build barriers using local materials instead of preconstructed containers, which was a more cost-effective and expedient method utilizing minimal resources. Similarly, one theme we heard in Ethiopia, Rwanda, and Senegal during U.S. Army medical readiness exercises was how adaptive our partners are. While U.S. medical professionals can sometimes rely too much on technology, our partners taught our soldiers how to adjust to a less resourceful environment—to do more with less. Our medical professionals learned to operate without relying on machinery and admired the creativity of our partners to cure patients without tools our soldiers previously thought essential. Such adaptive training left soldiers better prepared for combat deployments where technology inevitably fails.

Training on the African continent is unique; it offers a plethora of opportunities for training at every level, in austere and challenging environments, often with language barriers and diverse cultures. When training in African countries, American units typically deploy halfway across the world into areas that often lack roads and basic infrastructure that are taken for granted stateside. From the very beginning, a unit enters an environment full of more questions than answers, forcing leaders to adapt quickly and develop solutions independently. The Army strives to develop adaptive leaders who

possess cultural and geopolitical awareness to properly prepare subordinates for the places they will work, the people with whom they will operate, and the adversaries or enemies they will face ... Cultural understanding is crucial to the success of operations.<sup>3</sup>

Opportunities to train with our African partners can help build the type of leader the Army requires.

From observing major exercises on the continent involving headquarters staff, medical, engineering, military police, and infantry training, it is clear an exercise in the United States cannot replicate the natural challenges that a unit must face in many countries in Africa. Exercises on the continent expose U.S. soldiers

to partners of different militaries and varying experience levels, cultural and language barriers, and multi-agency and joint settings. This type of environment not only encourages creative and effective leadership but can also serve as a recruitment and retention tool. Throughout our missions, several service members across all branches and components of the military told us they would rather train in Africa experiencing real-world difficulties and challenges than in a simulated exercise at home.

During Justified Accord 19, elements from across the U.S. military deployed to Ethiopia to conduct a command post exercise, field training exercise, and medical readiness exercise. The infantry and engineer field training exercises were in a rural area nearly three hundred miles from the capital. When contracting support was insufficient in the remote outpost, Army engineer junior officers and NCOs took it upon themselves to design and execute expeditionary basic life support for their units in the training area. They lived an engineer's dream of building structures from the ground up to be utilized temporarily by their sister American units and by their partner forces permanently after the exercise. This contrasts with most exercises in the United States in which such structures must be demolished before the unit returns to home station. While the engineers benefited from creatively building and constructing improvised structures with few resources, their infantry peers thrived in the austere environment and gained a greater appreciation for their Ethiopian counterparts. While such environments were akin to combat deployment conditions for the American soldiers, they were normal training conditions for Ethiopian soldiers. Both field training exercises forced American soldiers to develop outside their comfort zones and build upon their innovative leadership.

Through a shared openness to learning from one another, our militaries can become stronger through each other's diverse backgrounds. Understanding how a partnership is mutually beneficial is key for senior leaders to appreciate that the effects of the bonds between militaries goes well beyond its high-ranking leaders.

## **The Power of Diplomacy and Professionalism**

In an era of strategic competition, one factor that sets the U.S. military apart from its peers is its



professionalism. Foreign partners often told us of their desire to emulate the American military. It was common to work and engage with high-ranking officers who previously attended U.S. military schools and utilized our doctrine and principles just as much as, if not more than, their own. In any engagement, the U.S. military uniform represents far more than the

soldiers and Army civilians whose collective expertise is the ethical design, generation, support, and application of landpower; serving under civilian authority; and entrusted to defend the Constitution and the rights and interests of the American people.<sup>5</sup>

The Army profession is empowered by and exists as a product of American democracy. To many of our

“The term ‘professionalism’ implies a duty to society without which the society could not thrive; in the case of the Army, it is a duty to defend.”

individual does; as such, all who wear it must serve as diplomats and professionals.

To be an Army professional means more than physical fitness and a crisp uniform. It means embodying “Trust, Honorable Service, Military Expertise, Stewardship, and Esprit de Corps.”<sup>4</sup> In an engagement, a senior leader must uphold these values and remember that everything they do is viewed as an example of U.S. Army professionalism. The standards are justifiably high, yet attainable. For example, the DCG began almost every morning with a run despite jet lag, late nights, and early morning meetings. These runs were also informal opportunities for a partner leader to join, and on occasion, even local children could not resist. The DCG was an expert on U.S. Army missions in Africa. Often with little time to prepare he could quickly study a read-ahead book or receive a five-minute brief before giving on the spot speeches or offering advice and guidance during the execution of an exercise. He did not shy away from but embraced the media and was always prepared to field questions. Every event was an opportunity to demonstrate U.S. military professionalism and the value of USARAF to our partners.

With Army professionalism as our comparative advantage, it was critical that the DCG represent this in every setting. The idea of professionalism goes beyond the individual and holds a deeper meaning with many of our partners’ desires for their own often nascent armies. To many of our partners, the U.S. Army is the standard bearer of military professionalism. The U.S. Army profession is defined as a trusted vocation of

partners, the uniform is synonymous with American ideals and freedoms.

The U.S. Army is a professional force under civilian control and consists of professionals who uphold the institution’s values of character, competence, and commitment.<sup>6</sup> Such a military represents what Ambassador Alexander Laskaris, former USAFRICOM deputy to the commander for civil-military engagement, describes as an army that people *run to* versus one that they *run from*.<sup>7</sup> Similar to the history of the U.S. military, many militaries in Africa are newly established and often trace their roots through a rebellion. Therefore, it is unsurprising that key leaders throughout Africa want to emulate the U.S. Army’s model—to be an army that protects and upholds the trust and respect of its citizens. After all, the term “professionalism” implies a duty to society without which the society could not thrive; in the case of the Army, it is a duty to defend.<sup>8</sup>

Another aspect that sets U.S. Army professionalism apart is the role of NCOs. NCOs are the backbone of the U.S. Army, and this aspect does not go unnoticed in Africa. As one African army chief of staff said during a formal meeting with the DCG, “If you have a strong NCO Corps you have a strong army.” During our travels throughout Africa, we observed that militaries varied greatly in their NCO corps and in how NCOs are utilized. Few countries in the world have a strong NCO corps, and often, officers do not empower their NCOs. The DCG made it a point to constantly discuss the role of NCOs and emphasize their value during



Sgt. Maj. Richard Thresher (*right*), senior enlisted leader of U.S. Africa Command, addresses Kenyan troops 18 December 2020 in Kenya. Warrant Officer Class One Elijah Koranga, Kenya Defense Forces sergeant major, invited Thresher to observe the culminating event of the newly developed Kenyan Command Course for noncommissioned officers (NCO)—a course implemented by Koranga following an African Enlisted Development Strategy key leader engagement in the United States in March 2020, when he visited NCO academies from each branch of the U.S. Armed Forces. (Photo courtesy of U.S. Africa Command)

his engagements. One of USAFRICOM's initiatives is to help our partners build their own NCO corps. The DCG's engagements were not one-sided as our partners recognized the worth and importance of NCOs but often lacked the systems to develop an effective corps, which was where our military could aid them. To help build more professional and effective partner militaries in Africa, the role of NCOs is essential, and it is the U.S. Army's example that represents yet another comparative advantage in the eyes of our partners.

## **Military Engagement as a Tool for Good Governance**

The military, political, social, and economic spheres of a country are necessarily intertwined. What may start as a purely military engagement amongst senior leaders can quickly and beneficially move across all sectors.

During exercise Shared Accord 19, nearly two dozen countries from across Africa came together to simulate a multinational headquarters in support of the UN mission to the Central African Republic. At the end of the exercise, leaders from every country were invited to attend a senior leader seminar and share their views on the greatest challenges faced by countries in Africa. Overwhelmingly, leaders from every region in Africa stated that corruption and poor governance are the roots of instability and conflict in most countries on the continent—not violent extremist organizations and not the conflicts themselves.

Our partner leaders also recognize that the upcoming population boom makes their desire for good governance imminent. By 2050, it is estimated that one in four people in the world will live in Africa, with 60 percent of that population under the age of

twenty-five.<sup>9</sup> It is no wonder that our partners regularly speak about economic development and governance as their countries' top priorities to decrease instability and conflict. In many countries we visited, the military is the strongest institution and integral to both economic development and political reform. Therefore, strong military relationships with our partners can also contribute to achieving economic and political initiatives.

The Rwanda Defence Force actively conducts citizen outreach programs to reduce poverty, increase the well-being of locals, and spur economic development. A country that a little over twenty-five years ago faced a genocide today focuses on fostering internal stability and on contributing to regional security. Rwanda is the fourth largest troop contributing country to UN peacekeeping operations in Africa.<sup>10</sup> Similarly, the Senegalese Armed Forces participate in the "Army Nation" concept in which the military oversees developmental construction projects such as schools, roads, and hospitals, which foster civil-military relations and economic empowerment. As examples in Rwanda and Senegal demonstrate, the military is often crucial to the overall picture within a whole-of-government approach to stability and peace in African countries. Security and development go hand in hand.

## The Importance of Persistent Engagement as Demonstrated by the State Partnership Program

Perhaps the best model for partnership building across military, political, and economic sectors in Africa is the National Guard's State Partnership Program (SPP). The SPP pairs a National Guard and its state with a country; there are eighty-five partnerships, sixteen with African countries.<sup>11</sup> The SPP goes beyond the military and "leverages whole-of-society relationships and capabilities to facilitate broader interagency and corollary engagements spanning military, government, economic and social spheres."<sup>12</sup> The National Guard is particularly well suited for this mission as it brings in the civilian expertise of its members and works with state governments. For example, the University of Vermont and the Vermont National Guard partnered with the Senegalese during a 2019 medical training exercise. The University of Vermont Medical Center donated two portable x-ray machines and the National Guard sent medical professionals to

provide services and share best practices with their partners.<sup>13</sup> In North Carolina, the relationship with Botswana includes partnerships in the agriculture and national emergency response sectors in addition to the military-to-military relationship.

Utilizing minimal resourcing, the SPP's strength comes in persistent engagement over a prolonged period. Throughout our travels, we heard stories of leaders in the United States and in African countries who grew up together, attending the same military training, and even sending their children to spend summers in each other's countries. All armies in Africa are significantly smaller than the U.S. Army, and while turnaround is common in the U.S. active-duty Army, it is not in the National Guard, which allows for engagement that is more consistent. Persistent engagement at a general officer level is also important.

As is the case in all hierarchical organizations, rank matters in the military. During engagements with our partners in Africa, the DCG was viewed as a decision-maker, which helped open many doors that enabled USARAF missions. The fact that the DCG took the time to meet with our partners demonstrated to them how important USARAF viewed their relationship. Our partners equally matched the DCG's rank or higher, showing their respect in turn. While persistent engagement at all levels is critical to a lasting partnership as demonstrated through the SPP, persistent engagement at the general officer level in Africa is key to strategic success.

## Empowering Aides

Another tool a senior leader often has at his or her disposal during senior leader engagements is an aide-de-camp. An empowered aide can serve as a second set of eyes and ears. While it may be seen as unprofessional or rude in many circumstances for a senior leader to jot down notes during his or her conversations, an aide bears the responsibility of noting any commitments made, requests for information, and summarizing topics covered during the conversation. These notes can later be used to inform other engagements, develop task lists for staff, and to write reports to inform a leader's organization. The DCG made it a pattern that when he engaged, his aide sat next to him and was more than welcome to join the conversation, no matter the rank of who he was meeting with. In this way, his aide was not seen as merely a note taker, which could cause suspicion, but instead

as an active participant. With an aide as a junior officer, often partner leaders enjoyed taking the time to explain concepts to his aide just as they would to their own junior leaders. When considering aides, senior leaders should consider selecting someone apt at note-taking and with whom they are comfortable conversing and working a room. With an empowered aide, engagements can transcend the room in which they take place, with notable information disseminated throughout a staff to increase planning efficiency and expertise for future operations and engagements.

## Summary

The positive or negative impact of senior leader engagements goes beyond the minimal resources required to execute them. For the cost of transportation and an

hour or two of time, partnerships can form that open doors for mutually beneficial opportunities, promote strategic objectives, and ultimately build networks to promote peace and stability globally. The basic principles of humility, promoting diversity of experiences, and professionalism can serve to inform key leaders in engagements around the world. Furthermore, an aide can be an additional asset within a senior leader's engagements. In an ever-connected and competitive world, the value of mutually beneficial relationships continues to grow. Understanding how to effectively engage is essential to maintaining a comparative advantage in the strategic competition over partnerships. ■

*The views expressed here are the authors and do not represent those of the U.S. Army or the Department of Defense.*

---

## Notes

1. U.S. Army Africa consolidated with U.S. Army Europe in 2020, increasing the leverage the U.S. Army can use to support efforts in the U.S. Africa Command (USAFRICOM) area of responsibility. The U.S. Army Southern European Task Force, Africa directly supports USAFRICOM as a joint-task-force-capable headquarters in addition to maintaining oversight and resourcing of hundreds of Army-supported theater security cooperation events in Africa each year.

2. "Change of Responsibility Ceremony," Defense Visual Information Distribution Service, 9 August 2019, accessed 16 September 2021, <https://www.dvidshub.net/video/702010/change-responsibility-ceremony>.

3. Army Doctrine Publication (ADP) 6-22, *Army Leadership and the Profession* (Washington, DC: U.S. Government Publishing Office, July 2019), 4-4–4-5, accessed 15 September 2021, [https://armypubs.army.mil/epubs/DR\\_pubs/DR\\_a/ARN20039-ADP\\_6-22-001-WEB-0.pdf](https://armypubs.army.mil/epubs/DR_pubs/DR_a/ARN20039-ADP_6-22-001-WEB-0.pdf).

4. *Ibid.*, 1-2.

5. *Ibid.*

6. *Ibid.*, 1-8.

7. Chris Karns, "Africa: A Continent Where Partnership is in Demand," *Military Times* (website), 23 March 2017, accessed 15 September 2021, <https://www.militarytimes.com/opinion/commentary/2019/03/23/africa-a-continent-where-partnership-is-in-demand/>.

8. ADP 6-22, *Army Leadership and the Profession*, 1-1, 1-7–1-9.

9. "Africa's Population Will Double by 2050," *The Economist* (website), 28 March 2020, accessed 15 September 2021, <https://www.economist.com/special-report/2020/03/26/africas-population-will-double-by-2050>; "Why Young, Urban or Rich Africans are Less Likely to Vote," *The Economist* (website), 22 February 2020, accessed 15 September 2021, <https://www.economist.com/middle-east-and-africa/2020/02/20/why-young-urban-or-rich-africans-are-less-likely-to-vote>.

10. "Troop and Police Contributors," United Nations Peacekeeping, accessed 27 March 2022, <https://peacekeeping.un.org/en/troop-and-police-contributors>.

11. "National Guard State Partnership Program," National Guard, accessed 4 January 2022, <https://www.nationalguard.mil/Portals/31/Documents/J-5/InternationalAffairs/StatePartnership-Program/NG%20SPP%20Map%20update%2001%20OCT%2021.pdf?ver=LT6tjAqgph2TE9nadGMA5w%3d%3d>.

12. "State Partnership Program," National Guard, accessed 28 December 2019, <https://www.nationalguard.mil/Leadership/Joint-Staff/J-5/International-Affairs-Division/State-Partnership-Program/>.

13. Jason Alvarez, "Portable X-Ray Machines," Defense Visual Information Distribution Service, 9 April 2019, accessed 15 September 2021, <https://www.dvidshub.net/image/5251629/portable-x-ray-machines>.

The Army  
University Press  
wants to hear  
from you!

*Publish  
with us*



The Army University Press provides writers with a suite of publishing venues to advance ideas and insights military professionals need to lead and succeed. Consider *Military Review*, the *Journal of Military Learning*, the NCO Journal, or the Combat Studies Institute to present cutting-edge thought and discussion on topics important to the Army and national defense.

Learn how to publish with Army University Press at <https://www.armyupress.army.mil/Publish-With-Us/>.





Soldiers from the 1st Cavalry Division and 11th Armored Cavalry Regiment plan an air assault training exercise supported by the 7th Squadron, 17th Cavalry Regiment, 28 February 2017 near the city of Dezashah during National Training Center rotation 17-04 at Fort Irwin, California. Effective Intelligence preparation of the battlefield is an essential component of the military decision-making process. (Photo by Pvt. Austin Anyzeski, U.S. Army)

# Assessing Mars

## A Holistic Framework for Land Forces Analysis

Chief Warrant Officer 2 Andrew L. Chadwick, PhD,  
U.S. Army National Guard

U.S. Army practices for assessing the capabilities of adversarial land forces need a major update. Namely, such practices place an insufficient emphasis on the critical human dimensions of a land force, such as leadership or morale. And, as the U.S. experience in Afghanistan shows, the human dimensions can play a decisive role in determining the outcomes of battles and even wars. Additionally, army intelligence practices tend to examine adversarial forces in isolation from friendly or allied units, which reduces opportunities to identify critical qualitative or quantitative imbalances. To address these analytical shortfalls, this article presents a holistic framework for land forces analysis that fuses U.S. Army intelligence preparation of the battlefield (IPB) techniques with methods employed by strategic intelligence organizations and military historians.

## What Is a Framework?

The primary value of a framework is that it lays out the key variables—something that changes in response to internal or external stimuli—of a particular system, event, or phenomenon under examination. This, in turn, helps guide the research and analysis of a topic by ensuring analysts properly account for each constituent part of a subject and the relationships between those parts. For example, an analysis of land forces must consider some basic variables including equipment, personnel, planning processes, and doctrine. It must also account for how those variables interact by showing, for instance, how an army's doctrine helps determine what equipment it acquires, how it trains, and more.

Ultimately, the value of an analytic framework is that it provides a sense of clarity and common language.<sup>1</sup> That is, it clarifies what is important and why. And, for organizations like the U.S. Army, it helps everyone speak the same language in how they approach the research, analysis, and presentation of their findings and assessments. This helps mitigate the tendency of some analysts to make judgments on the capabilities of a particular adversary on intuition alone or on incomplete analysis.

Despite their value, frameworks, as one historian rightly cautioned, are simplifications of reality and, therefore, “inexact and incomplete.”<sup>2</sup> In other words, having the framework does not guarantee an accurate

interpretation of a topic and it most certainly does not guarantee accurate predictions of how those topics will evolve over time or respond under certain circumstances. This is especially true of land forces analysis—and military analysis in general—in which analysts are operating with incomplete and at times contradictory evidence. And the wars and operations in which those land forces fight are inherently unpredictable. As Carl von Clausewitz observed in his analysis of war: “No other human activity is so continuously or universally bound up with chance.”<sup>3</sup> Chance—or unpredictability—reflects the fact that war is a social and political phenomenon determined largely by the actions, judgments, and misjudgments of people who, by nature, are unpredictable, especially as a collective and when under stressful conditions like war.<sup>4</sup>

## The Limits of U.S. Army Intelligence Preparation of the Battlefield

Even though Clausewitz is widely taught in U.S. military educational institutes, U.S. Army intelligence doctrine overlooks the human factors of war. The Army's current set of analytic tools, as detailed in IPB step 3 (evaluate the threat) in Army Techniques Publication (ATP) 2-01.3, *Intelligence Preparation of the Battlefield*, largely examines material and conceptual factors, such as enemy equipment, doctrine, and order of battle.<sup>5</sup> And for those variables, it does provide detailed guidance and useful tools, such as order of battle charts and threat templates that illustrate the means and methods an opposing force likely will employ in combat.<sup>6</sup>

Buried within the example templates in ATP 2-01.3 are important assessments regarding human factors, such as “force x lacks the will for prolonged engagements.”<sup>7</sup> However, ATP 2-01.3 provides incomplete guidance for how to make judgments regarding the human and material conditions that would cause a force to lack the will for

**Chief Warrant Officer 2 Andrew L. Chadwick, PhD, U.S. Army National Guard**, is an all-source intelligence technician with the 29th Infantry Division, Maryland Army National Guard. As a civilian, he serves as an intelligence analyst with the U.S. Department of Defense. He holds a PhD in history from the University of Maryland, College Park, and an MA in international security from the University of Denver.

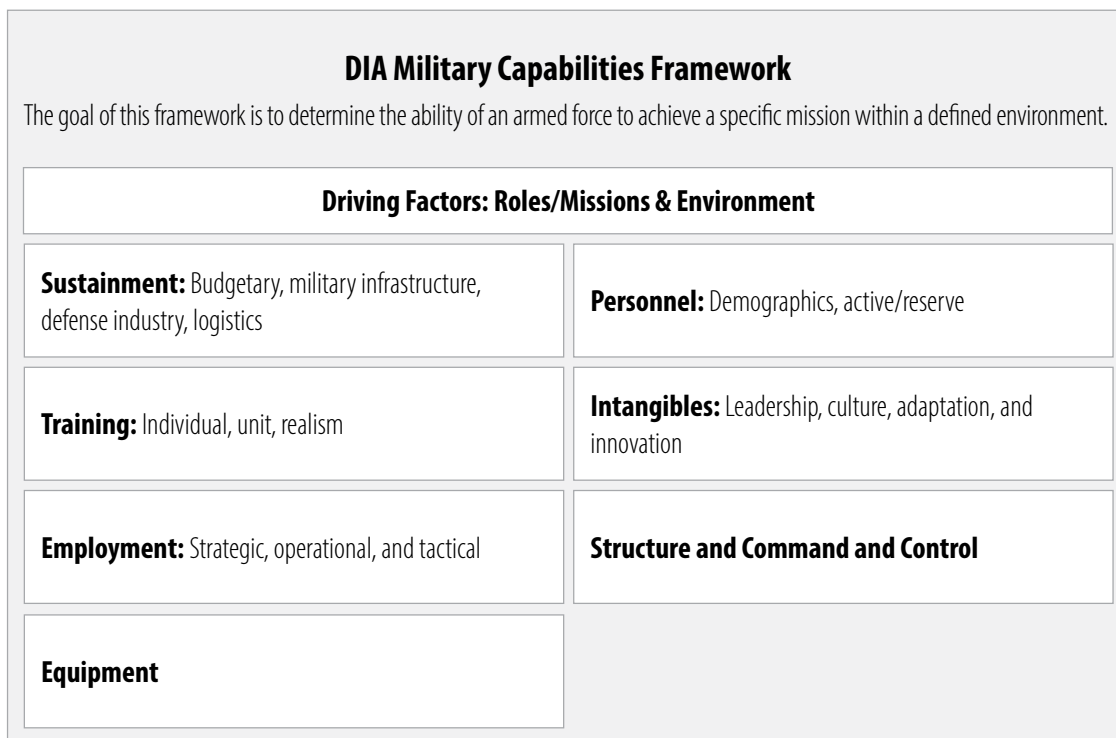

(Figure by the U.S. Defense Intelligence Agency)

**Figure. Defense Intelligence Agency Military Capabilities Framework**

prolonged engagements. Rather, ATP 2-01.3 essentially assumes analysts know how to obtain that information or that their higher echelons will provide it to them. Such assumptions are highly tenuous, given the varied skills, experience, motivation levels, enterprise endurance, and connectivity of formations across the army. In other words, doctrine must be more specific on how to acquire and employ that information using examples and more direct guidance.

Finally, ATP 2-01.3 fails to clearly break down its constituent variables, like composition and disposition, into their individual parts. Instead, it largely leaves that information up to analysts to figure out on their own, assuming they have the time and ability to do so. Fortunately, there is another framework available within U.S. Department of Defense that can help fill some of these gaps.

### Alternative Frameworks

The U.S. Defense Intelligence Agency’s (DIA) military capabilities framework uses a more comprehensive set of variables than the U.S. Army. As shown in the figure, the DIA framework breaks down the capabilities of a

military into nine key variables, two of which—roles/missions and environment—are considered driver variables.<sup>8</sup> Such variables are considered more important because they play a greater role in shaping the character of others. An army’s mission, for instance, and the terrain it fights on will play a critical role in shaping its structure, training, and equipment. And, unlike the U.S. Army’s IPB framework, the DIA breaks down some of its variables further by showing how personnel matters also must account for soldier demographics and whether they are active soldiers (full time) or reservists (part time).

The DIA framework, however, is still incomplete and is not focused on land forces, given its purpose to help inform military capabilities analysis in general. Its use of driver variables is important in that it shows how variables relate, unlike the U.S. Army’s IPB process. But it gives the impression that those variables (roles/missions and environment) are the only ones that shape the character of others. And the relationship also appears to be one way, not accounting for how factors like personnel and budgets can play extremely important roles in shaping an army’s roles and missions.



**Table 1. Millett and Murray's Military Effectiveness Framework**

Political	Strategic	Operational	Tactical
Obtain resources for the war effort/military by 1. Reliable access to financial support 2. Sufficient military-industrial base 3. Sufficient quantity and quality of manpower 4. Control over the conversion of resources into military capabilities 5. Political elite attitudes regarding the military 6. Officership as a distinct profession	Employ armed forces to achieve national goals by 1. Planning, analysis, and selection of objectives and linking those objectives to campaign or contingency plans 2. Ability to communicate plans and assessments to national leaders to seek logical goals 3. Consistency of force size and structure with strategic goals and courses of action 4. Alignment of strategic objectives with logistical, technological, and industrial bases 5. Integrating objectives with those of allies or ability to convince allies to align their objectives 6. Plans place the strengths of a military organization against the critical weaknesses of an adversary	Analysis, selection, and development of institutional concepts or doctrines for employing forces to achieve objectives in a theater of war. 1. Ethos to deal with operational problems in a realistic ways 2. Ability to combine capabilities to cover weaknesses and take full advantage of strengths 3. Ability to psychologically and physically adapt and move rapidly in unanticipated directions 4. Concepts are consistent with operational concepts and available technologies 5. Ability to support concepts with required intelligence, supply, communications, medical and transportation systems 6. Consistency of operational concepts to strategic objectives 7. Degree to which doctrine and organization places their strengths against an adversary's weaknesses	Techniques to fight engagements to meet operational objectives. 1. Tactical approaches consistent with strategic objectives 2. Extent concepts consistent with operational capabilities 3. Emphasis on all arms integration 4. Emphasis on surprise and rapid exploitation of opportunities 5. Consistent with morale, cohesion, and relations between noncommissioned officers, officers, and enlisted 6. Alignment of training to tactical systems 7. Alignment of training to support capabilities 8. What extent does tactical systems place strengths against adversaries weaknesses

(Table by author; adapted from Allan R. Millett and Williamson Murray, *Military Effectiveness: Volume 1, The First World War* [2010], 3)

The field of military history offers a more robust framework for land forces capabilities analysis. For example, in their multivolume study on military effectiveness, historians Allan Millett and Williamson Murray present a framework to assess and compare the effectiveness of multiple armies during the major wars of the twentieth century. They do so by looking at armies at all levels of command. To measure effectiveness, the volumes provide a list of general attributes, as shown in table 1, which account for human and material factors.<sup>9</sup> The authors also acknowledge those attributes reflect a host of different constraints, whether natural like geography, or political or cultural in nature, such as a society's willingness to serve in the military.<sup>10</sup> Ultimately, understanding these attributes and constraints will enable researchers to conduct more in-depth comparative studies of a particular armed force against its adversary under certain historical circumstances.<sup>11</sup>

The problem for military intelligence professionals, however, is that this framework focuses on informing the fields of strategic studies and military history. Thus,

it provides no guidance on how to employ its methods within existing U.S. Army staff processes.

In short, the above frameworks all have their own strengths and shortcomings. But unfortunately, the U.S. Army framework is the most incomplete, especially regarding human factors and matters above the tactical level. The proposed framework that follows aims to address these shortfalls.

## A Holistic Land Forces Framework

The following framework for land forces analysis is built on three core propositions. First, it must fit into the U.S. Army's existing IPB process to ensure it speaks the same language as the army professionals employing it. Second, it must be multivariable and account for the human factors that existing doctrine mostly overlooks. Finally, it must be comparative to identify relative strengths and weaknesses between friendly and adversarial forces.

Ultimately, what this framework should produce are two key outputs: (1) a land force category

## Table 2. Land Forces Category Statement

Variables		Examples	General Strength	General Weakness
<b>Primary Focus</b>	Internal Defense	Present-day Iraqi security forces	May be more prepared for conducting counterterrorism/counterinsurgency (CT/COIN) operations	Less prepared for conventional military operations against states
	Conventional Defensive Operations	Present-day Japanese armed forces	May be more prepared to defend against an attack from a state adversary	Less prepared for offensive operations against a state or COIN/CT scenarios
	Conventional Offensive Operations	Present-day U.S. Army	May be more prepared for offensive operations against a state	Less prepared for defensive operations against a state or COIN/CT scenarios
<b>Active Structure</b>	Short-service conscript (mandatory service for one to four years)	Israel Defense Forces	Likely capable of generating a large army relative to its population	Generally less well trained than longer service volunteers
	Long-service conscript (mandatory service for more than four years)	19th Century Russian and British armies	May be able to field a large and highly experienced army	Long-service conscript may lead to the growth of a large and expensive army
	Volunteer (service is voluntary and may extend beyond the typical one to four years of a conscript)	Present-day U.S. Army	Likely able to develop higher skills and more experience than conscripts	Are generally smaller than conscript armies; soldiers are more expensive to recruit and retain
	Cadre (an army that has small professional cadre that prepares to oversee an expanded wartime army composed of volunteers/conscripts)	U.S. and German armies during the interwar years (1920s and 30s)	Maintain highly skilled cadre of leaders; reduces financial costs of peacetime army	Unlikely to be ready for an unexpected conflict (need time to recruit and train new soldiers)
	Dual Structure (an army composed of a mixture of volunteers and conscripts)	Present-day Russian armed forces	Can create elite units within an army for offensive operations while the conscript units focus on easier tasks	Creates a dual structure in which some units are less ready for combat than others
<b>Reserve Structure</b>	Individual replacements/augmentees (reservists do not serve in complete deployable units, rather they are used to fill gaps in the ranks of active units)	Present-day U.K. Army Regular Reserve (separate from Army Reserve)	Allows reservists to fall under command of full-time personnel	No reserve units to replace exhausted/degraded active units
	Units (reserve units deploy as full units)	U.S. Army National Guard	Have a trained reserve capable of replacing exhausted/degraded active units	Quality of reserve units likely not on par with active-duty units, especially in armies that train reservists infrequently
	Militia/territorial defense (a reserve that does not deploy outside of its national borders and performs purely defensive functions)	Territorial defense forces of the present-day Baltic states	Relieves active-duty units of burden of routine tasks such as border security	Reserve unlikely to be deployable for missions abroad; quality is likely much lower than active-duty formations
	Hybrid (a reserve that consists of individual replacements and full, deployable units)	Present-day U.S. Army Reserve	Flexible reserve structure to fill immediate personnel needs in active army while providing reserve units to backfill/replace active-duty ones	Reduces amount of reserve units available to replace/augment active ones, given large percentage of reservists serving as individual replacements or augmentees
<b>Strategic Way of War</b>	Attritional (seeks to defeat enemy by slowly degrading its ability and will to fight over time)	French army in the interwar years (1920s and 30s)	Can deter adversaries by raising the prospects of a long and potentially costly war	Likely will struggle to conduct offensive operations and maneuver outside of prepared defenses
	Maneuver – Short War (seeks to defeat enemy through rapid offensive operations aimed at quickly destroying their will or ability to fight)	Present-day U.S. Army	Reduced likelihood of long, costly wars	Force may be ill-suited for withstanding heavy attrition or for waging a defensive war
	Indirect (seeks to avoid direct conflict and relies on proxies or standoff capabilities, like unmanned aerial vehicles [UAVs] and rockets, to degrade enemy's ability or will to fight)	Present-day Iranian military	Can reduce exposure to attack by relying on proxies or standoff attack capabilities	Likely to struggle in a force-on-force ground conflict

**Table 2. Land Forces Category Statement (continued)**

Variables		Examples	General Strength	General Weakness
Tactical Way of War	Multi-Domain (integration of air, maritime, cyber-electromagnetic warfare, and space capabilities)	Present-day U.S. Army and Russian army	Can converge an entire array of attack and defense capabilities to degrade opposing forces	Units may struggle to execute this high-skilled, high-tech form of war (especially if they are composed of short-service conscripts or undertrained reservists)
	Combined Arms (integration of armor, artillery, infantry, and combat engineering)	Present-day Israel Defense Forces	Can maximize the full combat potential of land force	Units may struggle to execute this high-skilled, high-tech form of war (especially if they are composed of short-service conscripts or untrained or undertrained reservists)
	Single Arm (formations composed primarily of a single arm)	Israel Defense Forces pre-1970s	May simplify planning, operations, and logistics	Likely at a disadvantage against a combined arms force; tanks (if present) will be more vulnerable to enemy infantry and antitank weapons; infantry may lack sufficient mobility and firepower to combat enemy tanks
Command and Control Arrangement	Centralized to Strategic-Level Commanders	Egyptian army 1967, 1973	Helps ensure unity of effort	Reduces chances to rapidly exploit opportunities; vulnerable to decapitation strikes
	Centralized to Operational-Level Commanders and Above	Cold War Soviet army		
	Flexible Mission Command Type Arrangement	Present-day U.S. Army	Helps enable more flexible operations to respond to threats and opportunities	Can reduce unity of effort
Tactical Formations	Corps and Above	Present-day U.S. Army		
	Division and Below	Present-day U.S. Army		
	Brigade and Below	Present-day Estonian Defense Forces		

**Example Category Statement:** The U.S. Army, which is an all-volunteer force backed by a fully deployable army reserve of units and individual replacements, is primarily focused on offensive operations against state adversaries. Its primary way of war is to end conflicts quickly through offensive maneuvers by brigade to army-sized units employing a flexible command arrangement overseeing combined arms and multi-domain capabilities. A key strength of the U.S. Army is its high-tech and high-skilled formations. A key weakness is its limited preparedness for COIN/CT operations and the high costs of its personnel and equipment, which reduces its ability to recover quickly from high battlefield attrition.

(Table by author)

statement and (2) a land forces capabilities statement. These outputs, moreover, should be incorporated at the beginning of IPB step 3 (evaluate the threat), setting the stage for a more detailed examination of doctrine, order of battle, and equipment.

**Land forces category statement.** Table 2 provides an overview of the key variables for determining the nature of a particular land force.<sup>12</sup> Namely, what are the force's purpose, structure, and ways of war? Answering

those questions enable analysts to produce a baseline assessment on the nature of a particular land force and its general strengths and weaknesses. This statement, in turn, can frame more detailed discussions regarding an adversary's capabilities by warfighting functions (fires, maneuver, protection, etc.).<sup>13</sup>

**Land forces capabilities statement.** Once the nature of a land force is established, then deeper analysis can occur regarding its ability to achieve a

**Table 3. General Land Forces Framework**

Strategic/National	Operational	Tactical
<p>1.1. Strategic plans place strengths against an adversary's weaknesses</p> <p>1.2. Military leaders willing and able to communicate honestly and effectively with national leaders</p> <p>1.3. State and society believes the mission at hand is critical to their security and is willing to devote time and resources to achieve the mission</p> <p>1.4. State has a history/national ethos that inspires/motivates soldiers</p> <p>1.5. Society respects and values military service</p> <p>1.6. Military is loyal to the state and is fully responsive to the orders of its national leaders</p> <p>1.7. Military is willing and able to recruit high-skilled and educated personnel</p> <p>1.8. Able to generate sufficient numbers of soldiers to meet mission requirements</p> <p>1.9. Has defined and practiced plans for mobilizing/integrating reserve units/individual replacements</p> <p>1.10. Land forces have access to strategic-level intelligence sensors that look deep into enemy's support areas for targeting, battle damage assessments, and warning of troop/equipment movements</p> <p>1.11. Has a professional officer corps built around a defined education/training program and a promotion system based on merit</p> <p>1.12. Has a professional noncommissioned officer (NCO) corps; officers trust and empower NCOs</p> <p>1.13. Land forces are somewhat or fully interoperable with main allies</p> <p>1.14. Military does not segregate units by ethnicity/language</p> <p>1.15. Units composed of soldiers who speak the same language</p> <p>1.16. Military has effective processes to identify and punish individuals for crimes, corruption, and other undisciplined behavior</p> <p>1.17. Not dependent on foreign suppliers for mission essential military equipment</p> <p>1.18. Is fighting on a single front/theater of operations (not confronted by attacks on multiple fronts)</p> <p>1.19. Key economic and population centers are protected from enemy attacks</p>	<p>2.1. Military has experience conducting the types of operations it is undertaking</p> <p>2.2. Operational plans are consistent with strategic plans/priorities</p> <p>2.3. Has a professional military education and training program for all ranks to build and enhance technical and leadership skills</p> <p>2.4. Has an organizational culture that values honest feedback and has mechanism for addressing such feedback</p> <p>2.5. Conducts dynamic training with an opposing force</p> <p>2.6. Trains in type of terrain they will operate in (urban, mountain, desert, etc.)</p> <p>2.7. Trains above the battalion-level</p> <p>2.8. Reserve units conduct individual and collective training in peacetime (at least fourteen to thirty days a year)</p> <p>2.9. Has a culture that demands full accountability and maintenance of equipment</p> <p>2.10. Has a multi-domain capability that can integrate land forces with air, cyber-electromagnetic warfare (EW), space, and maritime capabilities</p> <p>2.11. Employs a planning process that is used/understood throughout the force</p> <p>2.12. Has a flexible planning process that can adapt rapidly to changing circumstances</p> <p>2.13. Empowers mid and junior-level leaders to take the initiative</p> <p>2.14. Has an integrated air defense network for defending land forces from air and missile threats</p> <p>2.15. Has an information operations capability capable of producing timely and effective messages that resonate with targeted populations</p> <p>2.16. Has operational-level intelligence capabilities for identifying and tracking targets outside of tactical engagement areas/battle zones</p> <p>2.17. Has unified command to ensure unity of effort</p> <p>2.18. Has an organizational culture that is willing and able to experiment and innovate</p> <p>2.19. Has a quantitative advantage in forces over adversary</p>	<p>3.1. Tactics are consistent with operational plans</p> <p>3.2. Have defined tactical doctrine that is understood throughout the force and taught in school/training systems</p> <p>3.3. Corps, division, and brigade-level units have combined arms capabilities</p> <p>3.4. Corps, division, and brigade-level units have—or have access to—tactical EW and cyber capabilities</p> <p>3.5. Tactical units can request and receive air support from fixed-wing, rotary, and unmanned aircraft</p> <p>3.6. Tactical units have joint terminal attack coordinators to speed process of providing close air support to land forces</p> <p>3.7. Corps, division, and brigade-level units have tactical signal intelligence, geospatial intelligence, and mapping capabilities for enhancing situational awareness and targeting</p> <p>3.8. Tactical-level units have—or have access to—unmanned aircraft for intelligence, surveillance, and reconnaissance</p> <p>3.9. Able to field ad hoc task forces at the company to division-level</p> <p>3.10. Has a short-range air defense capability in tactical units for dealing with unmanned aerial vehicle, rotary, and fixed-wing aircraft threats.</p> <p>3.11. Has a tactical engineering capability for identifying, breaching, removing obstacles and for creating obstacles</p> <p>3.12. Has ability to provide timely resupply to tactical units engaged in combat</p> <p>3.13. Has an airborne and air assault (helicopter) infantry capability</p> <p>3.14. Has a culture and supporting programs for building and maintaining physical and mental fitness</p> <p>3.15. Tactical command, fires, and intelligence systems are able to communicate to provide a common operating picture and to inform targeting</p>

(Table by author)

specific purpose. To do so, analysts can use table 3 and table 4 (on page 75), which list broad attributes that can help determine the effectiveness of a land force at the strategic, operational, and tactical levels of command. Table 3 lists general attributes of an effective

land force, regardless of its intended purpose.<sup>14</sup> Table 4 focuses on conventional operations against a state adversary (attributes for effective counterterrorism/counterinsurgency operations are outside of the scope of this article).<sup>15</sup>

**Table 4. Conventional Land Forces Framework**

Strategic/National	Operational	Tactical
1.1. State has the willingness and ability to withstand heavy combat losses 1.2. If conducting expeditionary operations, has international transportation and logistics networks to project and sustain sufficient numbers of combat forces to achieve desired tasks 1.3. If operating on the defensive, has the territorial depth to absorb attack and recover 1.4. If operating on the offensive, has the element of surprise to catch defenders not fully prepared for attack	2.1. Has a long-range precision strike capability to destroy high valued targets in enemy support areas 2.2. Has a doctrine for engaging and defeating opposing forces in depth 2.3. Has specialized units and doctrine for defending support areas from opposing special operations and insurgent/militant forces 2.4. Strategic and operational-level intelligence organizations networked to tactical units to enhance situational awareness	3.1. Fires integrated with intelligence sensors to enable rapid identification, destruction, and assessment of targets 3.2. Fires systems have the same range or outrange the fires systems of opposing forces 3.3. Main battle tanks have the same range or outrange the systems of opposing forces 3.4. Has mechanized and/or motorized infantry capability 3.5. Infantry has antitank capabilities capable of defeating opposing main battle tanks 3.6. Has tactical human intelligence capability for conventional military operations (enemy prisoner of war debriefings)

(Table by author)

There are two ways to use the above frameworks. First, analysts can simply use these to guide their assessments regarding whether the land force under examination can perform a particular mission. The second method would be to make a quantitative assessment based on these attributes. Now, such an assessment can be problematic because wars and the land forces that fight in them are highly dynamic and generally defy quantitative analysis. That said, using the frameworks to produce quantifiable assessments can help enable the staff compare an adversarial force with friendly or allied forces.

To make such quantitative assessments, analysts should use a combination of intelligence reporting, finished intelligence from organizations like the National Ground Intelligence Center and the DIA, academic studies, and press reports to complete the following steps:

1. Finalize attributes, using or modifying the ones in the tables or adding others based on the situation.
2. Add a single point for each attribute that a land force meets in the general category (if the attribute is not applicable then do not add a point). And make sure to organize the final count by strategic, operational, and tactical categories, meaning the top score for strategy would be a 19 while a top

**Table 5. Israel versus Egypt, 1973**

Level of War	Total Score of Israel	Total Score of Egypt	Advantage
Strategic	13	16	Egypt
Operational	14	10	Israel
Tactical	10	10	Neutral

**Summary:** During the 1973 Yom Kippur War, Egypt had the strategic and tactical advantage over Israel because its attack across the Suez caught the Israelis by surprise and forced them to fight outnumbered on multiple fronts (Syrians attacked simultaneously in the Golan Heights). Egypt also neutralized Israel's main tactical advantages—its armored corps and air force—through the use of new antitank guided missiles and mobile surface-to-air systems (SAM). Egypt also crafted its war plan around its main strength: its ability to fight defense battles using well-rehearsed tactics. However, Israel was able to reverse the tide of the war when the Egyptians sacrificed these advantages and advanced beyond their protective SAM umbrella along the Suez Canal into the open deserts of the Sinai. This enabled Israel to take advantage of its superior tank gunnery and flexible operational and tactical culture to outgun and outmaneuver Egypt and bring the war to a close and prevent a deeper attack into Israeli territory. Despite the Israeli tactical and operational successes, Egypt still accomplished its primary strategic objective: compel Israel to reengage in diplomatic negotiations and return the Sinai to Egyptian control.

(Table by author)

operational score would be a 19 and a tactical score would top out at 15.

3. Repeat the same process for the conventional land forces framework.
4. Add the scores for the general and conventional frameworks to produce total scores for the strategic, operational, and tactical attributes (staffs could

also weigh some attributes higher than others, depending on the situations).

5. Redo the entire assessment process for the opposing force (note: the intelligence personnel should consult with other staff sections, especially when comparing adversarial forces to friendly forces).
6. Use the score to compare capabilities with opposing forces/allies, as depicted with a historical example in table 5 (on page 75).<sup>16</sup>
7. Continue with IPB step 3, building order of battle, equipment charts, threat models, and identify high valued targets. Then, transition to an examination of the adversary's likely courses of action as part of IPB step 4.

## Use by Echelon

The land force framework presented in this article is most suitable for employment by a division-level headquarters and above. Battalion and brigade intelligence staffs likely lack the time or resources to conduct an in-depth study of an adversarial land force, especially during combat operations. Thus, the division staff can use the framework to paint a broad picture of

the land forces under examination, providing context for brigades and battalions to develop more nuanced, tactically focused products.

The framework also has value in a competition environment by helping intelligence sections develop in-depth studies of the land forces within their particular area of responsibility. Such studies can help inform contingency planning and training plans to build partner capacity to compensate for any quantitative or qualitative imbalances with adversarial forces.

## Conclusion

The above framework, if incorporated into IPB step 3 (evaluate the threat), would likely help intelligence staff to form more holistic judgments on the nature, capabilities, and relative strengths and weaknesses of an adversarial land force. Like all frameworks, however, the one presented in this article is incomplete and cannot fully account for all the dimensions of a land force in every situation. But it can get the conversation started on how to conduct a holistic assessment of an adversarial force, which can enable more informed plans and decisions. ■

---

## Notes

1. John Lynn, *Battle: A History of Combat and Culture* (New York: Basic Books, 2004), 359.

2. *Ibid.*

3. Carl von Clausewitz, *On War*, ed. and trans. Michael Howard and Peter Paret (Princeton, NJ: Princeton University Press, 2008), 75, 101.

4. *Ibid.*, 101, 136.

5. Army Techniques Publication (ATP) 2-01.3, *Intelligence Preparation of the Battlefield* (Washington, DC: U.S. Government Publishing Office, 1 March 2019), 5-4, accessed 1 February 2022, [https://armypubs.army.mil/epubs/DR\\_pubs/DR\\_a/ARN31379-AT-P\\_2-01.3-001-WEB-4.pdf](https://armypubs.army.mil/epubs/DR_pubs/DR_a/ARN31379-AT-P_2-01.3-001-WEB-4.pdf).

6. *Ibid.*, 5-10.

7. *Ibid.*

8. Research Director, "Tradecraft Note 02-15: Assessing Military Capability," Analytic Tradecraft Guidance, 3 December 2015.

9. Allan R. Millett and Williamson Murray, *Military Effectiveness: Volume 1, The First World War* (New York: Cambridge University Press, 2010), 4-26.

10. *Ibid.*, 3.

11. *Ibid.*, 4-26.

12. Assessment derived from information in Abraham Rabinovich, *The Yom Kippur War: The Epic Encounter That Transformed the Middle East* (New York: Schocken, 2007); "World Factbook," CIA, accessed 19 February 2022, <https://www.cia.gov/the-world-factbook/>; "Who We Are: The Army Reserve," British Army, accessed 19 February 2022, <https://www.army.mod.uk/who-we-are/the-army-reserve/>; Eugenia C. Kiesling, *Arming Against Hitler: France and the Limits of Military Planning* (Lawrence, KS: University Press of Kansas, 1996); John Gooch, *Armies in Europe* (London: Routledge, 1980).

13. ATP 2-01.3, *Intelligence Preparation of the Battlefield*, 5-18.

14. Millett and Murray, *Military Effectiveness*, 4-26.

15. *Ibid.*

16. Assessment derived from information in Rabinovich, *The Yom Kippur War*.



A soldier from the 21st Theater Sustainment Command walks through a hangar inspecting cots 21 August 2021 at Ramstein Air Base, Germany, in preparation for arriving Afghan immigrants as part of U.S. Army Europe and Africa's support to Operation Allies Refuge. (Photo by Spc. Katelyn Myers, U.S. Army)

# The Theater Army's Central Role in Integrated Deterrence

Maj. Justin Magula, U.S. Army

*Now, integrated deterrence means using every military and non-military tool in our toolbox, in lock-step with our allies and partners. Integrated deterrence is about using existing capabilities, and building new ones, and deploying them all*

*in new and networked ways ... all tailored to a region's security landscape, and in growing partnership with our friends.*  
—Secretary of Defense Lloyd Austin

**D**uring a speech in July 2021, Secretary of Defense Lloyd Austin outlined his integrated deterrence concept. His idea advanced the Department of Defense's evolving competition concepts and incorporated many of the Army and joint competition fundamentals, which the new *National Defense Strategy* further develops.<sup>1</sup> In an effort to counter growing threats from adversaries below the level of armed conflict, Army and joint leaders have also placed increased emphasis on winning in competition short of armed conflict. As Gen. James McConville argues, the Army must learn how to win the “infinite game” of competition because it “helps to ensure that great power competition does not become great power conflict.”<sup>2</sup> The Army must continue combatting America's adversaries across all domains—land, air, sea, space, and cyber—to prevent them from achieving their objectives short of war.

Fortunately, the Army already employs an organization that can serve as the cornerstone of the integrated deterrence concept: the theater army. In addition to performing their enduring roles and functions, theater armies engage allies and partners, set and maintain a theater, and conduct limited contingency operations to enable the Army and joint force's success in competition. These unique organizations help the Army and joint force conduct all-domain operations and actively campaign to assure friendly nations; achieve integrated deterrence; and place geographic combatant commanders (GCC), the joint force, federal agencies, allies, and partners in a position of relative advantage to deter an adversarial attack; or rapidly respond if deterrence should fail. Theater armies will help the Army and joint force maintain a competitive edge over America's adversaries for the foreseeable future.

## Competition Concept Evolution since 2015

The idea of states in constant competition is not new, yet the Army only recently more clearly defined its role in military competition. The Army's concept of competition below the level of armed conflict emerged in a 2015 Army-Marine Corps white paper. U.S. Army Training and Doctrine Command (TRADOC) recognized that U.S. ground combat forces were not “sufficiently trained, organized, equipped, or postured to deter or defeat capable peer enemies.”<sup>3</sup> TRADOC later

explained these ideas in its 2017 publication, *Multi-Domain Battle*, which sought to put the Army in a better position compared to its adversaries using three tenets: calibrate force posture, employ resilient formations, and converge capabilities.<sup>4</sup>

Two joint publications also influenced Army competition concepts. The 2018 *Joint Concept for Integrated Campaigning* developed the idea of competition beyond the common binary peace-war construct and envisioned other roles for the joint force beyond just deterring adversaries during competition.<sup>5</sup> The following year, Joint Doctrine Note 1-19, *Competition Continuum*, elaborated upon these ideas by reiterating that the joint force must adopt a mindset of integrated campaigning to advance or defend U.S. interests short of armed conflict.<sup>6</sup> Competition usually occurs over extended periods, with indirect actions and less intense resource expenditure. Likewise, local successes rarely lead to an end to competition or permanent gains.<sup>7</sup> Future competition would require that the joint force maintain a persistent presence in theater, engaged in competition for extended durations.

In December 2018, the Army published two TRADOC pamphlets that further codified its competition concept: *The U.S. Army in Multi-Domain Operations 2028* and *U.S. Army Concept: Multi-Domain Combined Arms Operations at Echelons Above Brigade 2025-2045*. The *National Defense Strategy's* great-power competition idea and the newly published joint concepts greatly influenced each document.<sup>8</sup> *The U.S. Army in Multi-Domain Operations 2028* describes the United States in a state of continuous competition with China and Russia. In an effort to hamper its adversaries' actions, the Army would now use active engagement to “counter coercion, unconventional warfare, and information warfare directed at partners.”<sup>9</sup> Army forces would set conditions before conflict and consolidate gains as the joint force returned to competition. These pamphlets were the first to identify the theater army as the primary Army echelon converging capabilities across all domains in the physical, human, and information environments.

*Echelons Above Brigade 2025-2045* emphasizes the theater army's role in multi-domain operations (MDO). It recognizes that the Army must tailor theater armies and fill them with trained and ready personnel.<sup>10</sup> Theater armies set conditions for the





Secretary of Defense Lloyd J. Austin III delivers remarks and discusses his integrated deterrence concept 30 April 2021 during the change-of-command ceremony for Indo-Pacific Command at Joint Base Pearl Harbor-Hickam, Hawaii. (Photo by Petty Officer 2nd Class Anthony Rivera, U.S. Navy)

employment of landpower and defeat adversary aggression below armed conflict within their designated theaters. In MDO, theater armies remain focused on the entire theater of operations to sustain and support subordinate units at all times. Within the MDO framework, theater armies reside primarily in the operational support area, the friendly area where forces gain combat power, sustain operations, and project power into the support, close, and deep areas. They also coordinate with elements in the strategic support area to obtain the necessary strategic and national assets for use in theater.<sup>11</sup> With these documents, the Army made it clear that theater armies were an essential element of success in MDO.

Last year, the chief of staff of the Army published two strategic papers. The first, *Army Multi-Domain*

*Transformation*, outlines how the Army will meet its Aimpoint Force 2035 requirements. The Army will use “inside forces,” or those that operate inside an adversary’s antiaccess/area denial zones, to shape conditions within a theater and “outside forces” at the strategic and theater levels. The theater army serves as the hub between inside and outside forces. It strengthens the joint force by expanding the Department of Defense’s (DOD) landpower network, setting theaters through assured power projection and dynamic force employment, and developing new capabilities.<sup>12</sup> The white paper also describes the Army’s Calibrated Force Posture initiative, which requires an enduring Army presence in theater. Theater armies maintain a permanent presence and use a combination of assigned and rotational forces and key capabilities during competition to support the Calibrated Force Posture. The Army’s Regionally Aligned Readiness and Modernization Model will align units with combatant commands and joint, allied, and partner forces.<sup>13</sup> This alignment allows theater armies to build lasting relations with corps and divisions aligned within their area of responsibility (AOR), helping to expand the competition space.

The second chief of staff of the Army paper, *The Army in Military Competition*, further outlines the Army’s competition concept. This conceptual document defines military competition as the “range of activities and operations employed to achieve political objectives and to deny adversaries the ability to achieve objectives prejudicial to the United States.”<sup>14</sup> The Army can compete to achieve objectives without fighting, deter adversaries, ensure allies, or prepare for conflict. The paper also introduces the three dynamics of military competition: narrative, direct, and indirect. Narrative competition not only involves states competing for reputation but also serves as the baseline for the other two forms. Indirect competition sees states competing for advantage with interests that are less important or ill defined. In direct competition, states compete for leverage over well-defined and vital interests. The Army contributes to competition by presenting a credible force, enabling joint force escalation superiority, and offering policy makers a range of options.<sup>15</sup> Theater armies play a role in nearly every aspect of the three dynamics of military competition and occupy a central piece of the Army’s competition concept.



## Theater Army Organization, Roles, and Functions

Theater armies serve as the Army's primary competition headquarters and a hub for integrated deterrence operations. The Army recently began altering theater army headquarters, their assigned forces, and theater enablers to do more in competition. Currently, the Army fields five theater armies, each in support of a GCC: U.S. Army North (USARNORTH) for U.S. Northern Command, U.S. Army South (USARSO) for U.S. Southern Command, U.S. Army Central (USARCENT) for U.S. Central Command, U.S. Army Pacific (USARPAC) for U.S. Indo-Pacific Command, and U.S. Army Europe-Africa (USAREUR-AF) for U.S. European Command and U.S. African Command.

Theater armies contain three headquarters components, each with specific functions: a main command post (MCP), a contingency command post (CCP), and a headquarters and headquarters battalion. Though part of the same headquarters, the MCP primarily serves as an administrative headquarters focused on the entire theater while the CCP conducts limited,

Soldiers under the command of U.S. Army North walk down a vehicle trail 4 September 2021 while deployed in support of the Department of Defense wildland firefighting response operations for the Dixie Fire in California. (Photo by Sgt. Deion Kean, U.S. Army)

operational missions. The headquarters and headquarters battalion provides administrative and logistical support to the MCP and CCP, including sustainment to the CCP when it deploys. Theater army commanders can tailor the MCP or CCP to accomplish AOR-specific, short-duration or enduring missions.

The CCP serves as an immediately available, deployable command post for small-scale operations or as the foundation of a joint headquarters. It can also form the nucleus of a small joint task force (JTF) or joint forces land component command (JFLCC) headquarters under a JTF or GCC commander.<sup>16</sup> The MCP will provide direct planning support and reach-back capability when the CCP deploys for operations, exercises, or theater security cooperation activities. For instance, USARSO routinely deploys its CCP for foreign disaster relief (FDR) and foreign humanitarian

assistance (FHA) missions in the Caribbean during hurricane season.

Until 2014, theater armies also included an operational command post (OCP) to perform traditional field army roles, like those that USARCENT employed to manage operations in Iraq, Syria, and Afghanistan. The Army is reportedly exploring options to add OCP capabilities back into theater army headquarters to improve their ability to manage competition operations. An OCP could oversee theater army forces and employ joint theater enablers in a joint operations area (JOA), allowing the MCP to maintain its theater-wide focus. Together, the theater army's dual-role headquarters and potential OCP additions, combined with its assigned forces and joint enablers, make it capable of performing various roles that enable Army and joint success.

Theater armies derive their roles, functions, tasks, and responsibilities from various documents, including Title 10 U.S.C.; Army Regulation 10-87, *Army Commands, Army Service Component Commands, and Direct Reporting Units*; and Department of Defense Directives 5100.01 and 5101.1.<sup>17</sup> Theater armies perform ten of the twelve Army responsibilities outlined in these documents.<sup>18</sup> They support the joint force across the range of military operations short of conflict: military engagement, security cooperation, deterrence, crisis response, and limited contingency operations.<sup>19</sup> A theater army serves both the Department of the Army and the GCC, acting as a conduit to Army headquarters on behalf of its supported GCC.<sup>20</sup> By doing so, a theater army helps the Army tailor the forces it will deploy to support a combatant commander's requirements for operations across the competition continuum.

The theater army daily performs its primary role as the Army service component command (ASCC) to a GCC. A theater army is responsible for all administration and support of all Army forces under the GCC or transitioning into the theater. Typically, a theater army handles these same roles in support of Army forces deployed in a JOA. A GCC could require its aligned theater army to serve as a JTF or JOA JFLCC for immediate response and contingency operations. However, operating in these roles for extended periods requires augmentation and inhibits a theater army from fulfilling its ASCC, theater-wide responsibilities. For example, Third Army

required significant staff augmentation to execute its mission in Operations Desert Storm and Iraqi Freedom, where it operated as a JOA JFLCC, Army forces, and theater JFLCC.<sup>21</sup> Conversely, a theater army can execute multiple competition roles without significant headquarters augmentation while serving as a theater JFLCC, such as U.S. Army Pacific has done since 2014.<sup>22</sup>

A theater army plans, coordinates, and fulfills the combatant commander's daily operational requirements and its ASCC responsibilities through its MCP. The headquarters provides theater-wide Title 10, administrative control (ADCON); Army support to other services; and Army executive agent responsibilities in support of the GCC.<sup>23</sup> By performing each enduring commitment, the theater army provides essential support to the Army and joint force. For instance, ADCON responsibilities include personnel management, logistics support, training, personnel services, and deploying troops.<sup>24</sup> A theater army can provide Army support to other services through fuel distribution, engineering, base defense, communications network infrastructure, land-based air missile defense, intratheater medical evacuation, common-user logistics, and other support roles.<sup>25</sup> For example, a theater army would provide substantial support to units like a Marine expeditionary force that lacks robust, organic sustainment capabilities. Additionally, the theater army could use assigned units like the battlefield coordination detachment to liaise with the joint force air component commander to synchronize joint fires across the AOR or digital liaison detachments to assist with multinational interoperability.

Theater armies also carry out Army executive agent responsibilities for essential theater-wide functions such as the military postal service, contracting activities, and DOD support to United Nations missions.<sup>26</sup> The MCP supports forward deployed Army, joint, and multinational forces deployed to a JOA established within the AOR. Often, theater armies allocate resources and delegate missions to subordinate theater-enabling commands or brigades, which then complete the detailed planning and execution to meet ASCC responsibilities.

A theater army performs seven functions that allow it to accomplish its ASCC role:

- exercise command and control over Army forces in a theater,



- ◆ execute combatant commander's daily operation requirements,
- ◆ provide ADCON of Army forces,
- ◆ set and maintain the theater,
- ◆ set and support operational areas,
- ◆ plan and coordinate consolidation of gains, and
- ◆ perform joint roles in limited scope, scale, and duration.<sup>27</sup>

These functions extend the joint force's operational reach and allow it to contest adversaries in all domains. While it is helpful to understand the functions, roles, and tasks that a theater army performs, simply reviewing these areas limits our appreciation of how a theater army supports integrated deterrence.

## How Theater Armies Support Integrated Deterrence

Many of the theater army's responsibilities that directly support integrated deterrence fall under three broad categories: engage allies and partners, set and maintain the theater, and conduct limited contingency operations. Tasks within these categories often overlap and mutually support each other. By daily fulfilling tasks

Soldiers with the 7th Transportation Brigade-Expeditionary, under operational control of the 8th Theater Sustainment Command, download Army prepositioned stock in Guam on 9 July 2021 in support of theater army and joint force exercises. (Photo by Staff Sgt. Kevin Martin, U.S. Army Pacific Public Affairs Office)

within these categories, theater armies enable the Army and joint force to conduct integrated campaigning. These highly capable headquarters leverage allies and partners, converge capabilities, prepare a theater, and support the joint force's efforts to achieve integrated deterrence.

**Engage allies and partners.** Theater armies engage allies and partners directly. They also oversee and employ subordinate units in various missions that support this line of effort. At its headquarters, a theater army prepares a theater campaign support plan "to organize and align operations, activities, events and investments in time, space and purpose to achieve strategic effect."<sup>28</sup> A theater army shapes the environment and maintains regional stability by engaging allies and partners to improve their military capabilities and capacity. Engagement increases the theater army's access and

influence in the AOR. It also expands the DOD's global landpower network, the network of allies and partners that sets a foundation for joint and whole-of-government strategic engagement.<sup>29</sup> Additionally, through routine interactions, a theater army prevents adversaries like Russia and China from building influence with allies and partners. Theater armies grow the landpower network through military engagement, education and exercises, and security cooperation.

Military engagement involves the frequent contact and interaction between U.S. forces and those of another nation's armed forces or foreign and domestic civilian agencies.<sup>30</sup> Success begins with a presence on the ground that starts at the top. Long-term partnerships and exchanges between senior leaders boost interoperability and shared trust. For instance, USARPAC, USAREUR-AF, and USARCENT all have deputy commanders from partner nations serving in their headquarters. Army commanders from these AORs demonstrate commitment by routinely engaging in senior leader discussions and attending events such as the annual Land Forces Pacific Symposium or African Land Forces Colloquium that "encourage other nations to choose the United States as the security partner of choice."<sup>31</sup> Theater army elements stationed forward in the Pacific, Europe, and the Middle East can interact with host-nation militaries daily to increase the interoperability and communication between nations. For example, USARPAC permanently stations two digital liaison detachments with South Korean field armies. Military engagement also includes Army interaction with foreign and domestic civilian agencies. For instance, the State Partnership Program builds enduring ties between U.S. forces and its partners through efforts such as training peacekeepers in Kenya and preparing regional partners for natural disasters in South America.<sup>32</sup>

Exercises and education also enable the Army to expand the landpower network and prepare for future operations with allies and partners. These endeavors support the Army in direct, indirect, and narrative competition. Directly, they showcase deterrent capabilities in action. For example, USAREUR-AF's DEFENDER-Europe 21 included twenty-eight thousand troops from twenty-seven partner nations, testing the theater army's ability to command and control multinational forces while maintaining theater-wide oversight of 104 countries.<sup>33</sup> Multinational exercises

contribute to indirect competition by providing value to allies and partners through officer exchanges, information sharing, and mutual logistics support.<sup>34</sup> These exercises support narrative competition by demonstrating America's commitment to its partners and allies.

Theater armies also nominate partner and allied officers to attend U.S. Army training courses and professional military education. For instance, the U.S. Army War College's C/JFLCC course routinely graduates ten to fifteen foreign general officers per year. Meanwhile, the current War College resident course has eighty international fellows from seventy-five countries.<sup>35</sup> These graduates build lifelong relationships with their U.S. counterparts that improve allied and partner cooperation.

Security cooperation provides one more key avenue by which theater armies engage allies and partners. Through security cooperation, theater armies improve partner nation capacity and capability, expand influence and access, and encourage partners to support U.S. interests.<sup>36</sup> Ideally, a theater army and its subordinate unit's efforts improve their partners' ability to manage internal and external threats, allowing host-nation governments to maintain the rule of law. One way that the theater army does this is through security force assistance (SFA). The Army's SFA brigades, or SFABs, advise foreign security forces and conduct SFA up to the corps level. Their efforts support theater security cooperation objectives. As Army Secretary Christine Wormuth recently said, the Army can use SFABs to "develop and deepen relationships, create opportunities for greater access, [and] create opportunities for interoperability."<sup>37</sup>

Theater armies oversee foreign internal defense, security sector reform, and foreign military sales. While special operations generally perform foreign internal defense, theater armies provide logistics to these missions and perform complementary SFA missions simultaneously. Theater armies also support security sector reform in host nations. For example, USARSO

**Maj. Justin Magula, U.S. Army**, is an Army strategist in the Strategic Landpower and Futures Group at the U.S. Army War College. He holds a master's degree in international public policy from Johns Hopkins University and a BS in international relations from the U.S. Military Academy. He previously served in the 4th Battlefield Coordination Detachment and the 101st Airborne Division.

recently cohosted the Border Security Conference in Brazil to coordinate border security with its South and Central American partners.<sup>38</sup> Similarly, foreign military sales advance U.S. influence with allies and partners. U.S. Army Security Assistance Command manages more than 6,500 foreign military sales cases valued at more than \$200 billion with countries in every combatant command AOR.<sup>39</sup> Through its missions engaging allies and partners, a theater army and its subordinate units improve national security through well-postured, prepared, and interoperable partners, thus enabling increased access for the joint force across each combatant command.<sup>40</sup>

**Set and maintain the theater.** The second major grouping of theater army tasks falls under setting and maintaining a theater. Setting a theater relies heavily on enduring relationships with allies and partners. By expanding the DOD's landpower network, the theater army improves its ability to set and maintain the theater for the joint force.<sup>41</sup> Theater armies provide combatant commanders with theater-wide intelligence, mission command, information advantage, protection, sustainment support, and unique deterrent assets.<sup>42</sup> Setting the theater allows combatant commanders to execute their campaign and strategic plans successfully. Prepared theaters also extend the joint force's operational reach and ability to sustain integrated campaigning efforts.

Theater armies collect, produce, and disseminate intelligence using signal, geospatial, counterintelligence, human, open source, atmospheric, and other intelligence capabilities. By doing so, they develop regional theater databases and signatures, support deterrence activities, provide warning intelligence, and improve contingency plans.<sup>43</sup> Each theater army employs a military intelligence brigade-theater to help prepare the theater or JOA for competition activities. These brigades support joint targeting and provide a gateway for a theater army to access national-level intelligence.

As part of its mission command efforts, theater armies ensure that GCCs have appropriately tailored and postured forces who can communicate effectively with other Army units and the joint force. Theater armies tailor forces and deploy them to support a GCC for competition activities including contingency operations. Force tailoring is a continuous process as troops move in and out of the theater. Theater armies ensure that those forces are postured appropriately to

support GCC operation plans and contingency plans, deter adversaries, and assure partners. A theater army provides command and control (C2) through theater-wide communications to the Army and the joint force. A signal command (theater) helps the theater army establish, maintain, and defend the communications and network architecture for Army forces in a JOA and provides connectivity between land forces and the rest of the AOR. Theater armies place the right Army forces in the right location and at the right time to dynamically employ and converge landpower in support of a GCC's objectives.

Theater armies also establish and maintain information advantage to support GCC campaign plans. Headquarters staff personnel currently plan nonlethal fires, but some theater armies might soon field an experimental unit called the Theater Information Advantage Element (TIAE). The TIAE will "converge theater aligned information related capabilities across the operational environment to support decision making, protect friendly information, and affect relevant actor perceptions, attitudes, and behaviors in order to gain and maintain information advantage."<sup>44</sup> TIAEs will fight to win the information space and enable successful narrative competition. Theater armies will be able to merge operations in the physical and information domains to influence both friendly and enemy actions.<sup>45</sup>

Theater armies protect U.S. forces, infrastructure, allies and partners, and other critical assets. Theater army protection comprises many tasks such as force health protection; personnel recovery; physical security; area security; chemical, biological, radiological, and nuclear (CBRN) operations; police and detention operations; and air and missile defense. These actions protect American and partner forces and prevent adversaries from gaining positions of advantage that could disrupt theater or JOA operations. Theater armies help maintain ground, air, and sea lines of communication through the employment of port, airfield, and critical infrastructure protection assets. Units like the Army Air and Missile Defense Command, 20th CBRNE Support Command, theater military police commands, maneuver enhancement or protection brigades, and regional support groups perform many essential protection functions. By positioning units appropriately, a theater army ensures that it can protect troops and infrastructure and maintain the theater for continuous operations.



The U.S. Army Central contingency command post (CP) on 5 May 2017 at the joint training center in Jordan. U.S. Army Central established the CP to standard in less than sixty hours as part of preparations for Exercise Eager Lion 17, an annual multinational exercise with over eighteen partner nations. (Photo by Sgt. Zoe Morris, U.S. Central Command)

A theater army employs unique deterrence units and capabilities, and can coordinate for national-level assets. These units demonstrate to an adversary that U.S. forces can hold their interests at risk. For example, the multi-domain task force is a theater-level element that synchronizes precision effects and fires in all domains against enemy antiaccess/area denial networks, enabling joint freedom of action.<sup>46</sup> Theater fires commands and elements will control long-range fires and hold an adversary at risk while friendly forces maintain significant standoff. The Intelligence, Information, Cyber, Electronic Warfare and Space unit will enable the Army to conduct MDO, enable freedom of action in space, contest adversaries in the cyber domain, and open windows of opportunity in the information environment.<sup>47</sup> Together, these new organizations will deliver effects from all domains to create multiple dilemmas for an adversary, enable joint force decision dominance, and create a significant deterrent effect.

Lastly, theater armies set and maintain a theater through the category most commonly associated with setting a theater: sustainment. Every day, through its theater sustainment command (TSC), the theater

army provides logistics, financial management, contracting support, and personnel services to Army forces in the AOR.<sup>48</sup> Theater armies provide transportation, construct and operate bases, assess critical infrastructure, deploy and redeploy forces, and maintain the Army prepositioned stock enterprise. For example, theater engineer commands provide C2 for engineer brigades in theater that can construct, maintain, and assess lines of communication, seaports, and airfields to ensure that they can maintain sustainment requirements for theater-wide and JOA-specific missions.

TSCs not only provide sustainment but also establish and maintain distribution networks. The 1st TSC has supported USARCENT since 2006, managing the “ports, flights, and customs points needed

to keep people and equipment moving 24 hours a day, seven days a week” in the CENTCOM AOR.<sup>49</sup> As an illustration of a theater army’s massive scope of sustainment requirements, 1st TSC provides 40,000 meals, 3 million gallons of fuel, 750 tons of cargo, and 135,000 pieces of mail across twenty countries each day.<sup>50</sup> Theater army planners and theater medical commands



provide and coordinate medical, dental, and veterinary support across AORs for a GCC. Additionally, they leverage relationships with allies and partners to establish basing, overflight, and status of forces agreements. These activities continuously shape the environment for the Army to employ landpower in support of the joint force and GCCs.

**Conduct limited contingency operations.** Theater armies also conduct limited contingency operations covering a broad range of missions. Success in contingency operations relies on effective engagement with allies and partners and the theater army’s ability to set and maintain the theater. The theater army CCP is well suited to provide C2 for Army or joint forces conducting limited contingency operations, to include FHA, FDR, defense support of civil authorities, noncombatant evacuation operations, peace operations, and CBRN response. CCPs can deploy their organic personnel and equipment by aircraft and C2 up to a division-size element.<sup>51</sup> The CCP could serve as a JFLCC or JTF commander or operate under another joint force commander. Regardless, the CCP will require augmentation of its staff and support from theater enablers.

Each theater army CCP stands ready to respond to various missions. For example, USARNORTH serves as the standing JFLCC for the U.S. Northern Command AOR. Its CCP can rapidly deploy and has communications that allow it to integrate with joint, interagency,

In partnership with Guatemalan forces, Joint Task Force-Bravo unloads emergency supplies from a U.S. Army CH-47 Chinook assigned to the 1st Battalion, 228th Aviation Regiment in Alta Verapaz, Guatemala, 8 November 2020 to assist the victims of Tropical Depression Eta. (Photo by Capt. Rachel Salpietra, U.S. Air Force)

state, federal, and local authorities. Theater armies can also base their CCP forward in theater. USARCENT routinely bases its CCP in Kuwait for exercises and operations in its AOR, like when it served as the Operation Inherent Resolve CJTF headquarters in 2014.

A theater army can C2 FHA or FDR missions, even in nonpermissive environments. For example, U.S. Army Africa initially oversaw the DOD’s response to the Ebola virus outbreak in West Africa during Operation United Assistance. Maj. Gen. Darryl Williams, then USARAF commander, operated as the joint force commander. The CCP quickly “assessed the operational environment, developed relationships, began operations, identified follow-on requirements, and established the infrastructure for subsequent forces,” ensuring that the operation got off on the right foot.<sup>52</sup> Some CCPs deploy routinely. USARSO’s CCP maintains a high level of readiness, especially during hurricane season.<sup>53</sup> The CCP has deployed to conduct FHA and FDR efforts after multiple hurricanes, tropical storms, and Haitian earthquakes in 2010 and 2021.



Theater army CCPs also conduct defense support of civil authorities missions. USARNORTH regularly responds to natural and man-made disasters in the United States. The CCP has long-standing relations with government agencies at the federal and state level, such as USARNORTH's defense coordinating elements aligned with FEMA's regional headquarters. Last year, USARNORTH supported and oversaw the DOD's ground response to the Dixie Fire in California. As Lt. Gen. John Evans said, "It is our duty and our honor to support the National Interagency Fire Center's efforts to suppress the Dixie Fire and protect those threatened by it."<sup>54</sup> USARNORTH also served as the JFLCC for DOD's efforts in the fight against COVID-19, supervising Navy and Air Force medical teams. Theater armies can also conduct noncombatant evacuation operations, such as Operations Assured Guardian in Africa and Operation Allies Refuge to rescue Afghan civilians. They can also serve as a headquarters in the initial stages of peacekeeping operations. Contingency command post missions help the Army expand its landpower network and gain influence through indirect and narrative competition. "Countries remember which partners provided timely, useful assistance," thus giving the United States future leverage over its competitors.<sup>55</sup>

Every role, function, and task that a theater army performs mutually supports the others. When a theater army engages allies and partners effectively, it improves host-nation capacity and capability. This engagement expands the landpower network and provides the Army with increased influence and options during future operations. Established relationships allow the Army to better set and maintain a theater for the joint force by having supporting agreements in place that allow forces access to host nation facilities. For instance, USARPAC uses its Pacific Pathways initiative to improve its partners' military effectiveness and interoperability with the joint force. If USARPAC is required to conduct a contingency

operation in the region, it will now have more effective partners and a further established theater from which to operate. These overlapping tasks ultimately enable a theater army to oversee a complex array of operations across its AOR in support of GCC and national objectives.

## Conclusion

Future Army and joint competition concepts call for a military that can deter enemy aggression, assure allies and partners, provide joint force escalation superiority, and give policymakers a maximum amount of options. No other organization supports these future competition and integrated deterrence concepts more than the theater army. Through their forward presence, these tailorable and multipurpose headquarters, along with their unique forces and theater enablers, orchestrate actions across vast distances that impact the Nation's ability to win in operations short of armed conflict.

A theater army allows for further Army and joint success in continued competition and sets the stage for American military forces to respond and win during crises, transition to armed conflict, or conflict. Theater armies engage allies and partners to extend the landpower network, set and maintain the theater to support Army and joint operations in all domains, and respond to limited contingency operations to increase influence, access, and freedom of action. Whether setting the theater in the Pacific, conducting multinational exercises in the Middle East, fighting wildfires in California, supporting noncombatant evacuation operations at Ramstein Air Base, or rebuilding essential services after severe weather events in South America, each theater army competes daily to support its combatant command, negate adversarial advantages, and empower the joint force. Theater armies provide strategic landpower that remains indispensable to the joint force's and our Nation's future ability to achieve integrated deterrence. ■

## Notes

**Epigraph.** Lloyd J. Austin III, "Secretary of Defense Remarks at the 40th International Institute for Strategic Studies Fullerton Lecture (As Prepared)" (speech, International Institute for Strategic Studies, Singapore, 27 July 2021), accessed 29 November

2021, <https://www.defense.gov/News/Speeches/Speech/Article/2708192/secretary-of-defense-remarks-at-the-40th-international-institute-for-strategic/>.

1. While the 2022 *National Defense Strategy* presents new concepts and terminology, this article uses the term "competition" as found in current Army and joint concepts to refer to Army and joint force operations and actions short of armed conflict.
2. James C. McConville, *The Army in Military Competition: Chief of Staff Paper #2* (Washington, DC: Headquarters, Department of the Army, 1 March 2021), ii.
3. David G. Perkins, "Multi-Domain Battle: Driving Change to Win in the Future," *Military Review* 97, no. 4 (July-August 2017): 9.
4. U.S. Army Training and Doctrine Command (TRADOC), *Multi-Domain Battle: Evolution of Combined Arms for the 21st Century 2025-2040* (Fort Eustis, VA: TRADOC, December 2017), 2.
5. U.S. Joint Chiefs of Staff, *Joint Concept for Integrated Campaigning* (Washington, DC: U.S. Joint Chiefs of Staff, 8 March 2018), vi.
6. Joint Doctrine Note 1-19, *Competition Continuum* (Washington, DC: U.S. Joint Chiefs of Staff, 3 June 2019), 5.
7. *Ibid.*, 8-9.
8. See Office of the Secretary of Defense, *Summary of the 2018 National Defense Strategy of the United States of America* (Washington, DC: Department of Defense, 2018); U.S. Joint Chiefs of Staff, *Joint Concept for Integrated Campaigning*.
9. TRADOC Pamphlet (TP) 525-3-1, *The U.S. Army in Multi-Domain Operations 2018* (Fort Eustis, VA: TRADOC, 6 December 2018), vii.
10. TP 525-3-8, *U.S. Army Concept: Multi-Domain Combined Arms Operations at Echelons Above Brigade 2025-2045* (Fort Eustis, VA: TRADOC, 6 December 2018), 32.
11. *Ibid.*, 52.
12. James C. McConville, *Army Multi-Domain Transformation: Chief of Staff Paper #1* (Washington, DC: Headquarters, Department of the Army, 16 March 2021), 15-19.
13. *Ibid.*, 23-24.
14. McConville, *Chief of Staff Paper #2*, 1.
15. *Ibid.*, 2-5.
16. Joint Publication (JP) 3-31, *Joint Land Operations* (Washington, DC: U.S. Government Publishing Office [GPO], 3 October 2019), II-10.
17. See 10 U.S.C. § 7013 (1956); Army Regulation (AR) 10-87, *Army Commands, Army Service Component Commands, and Direct Reporting Units* (Washington, DC: U.S. Government Printing Office, 4 September 2007); Department of Defense Directive (DODD) 5100.01, *Functions of the Department of Defense and Its Major Components* (Washington, DC: U.S. Government Printing Office, 21 December 2010); DODD 5101.1, *DoD Executive Agent* (Washington, DC: U.S. Government Printing Office, 3 September 2003).
18. See 10 U.S.C. § 7013; Army Techniques Publication (ATP) 3-93, *Theater Army Operations* (Washington, DC: U.S. GPO, August 2021), 4-1-4.2. The ten responsibilities that a theater army performs are: organizing, supplying, equipping, training, servicing, mobilizing, demobilizing, administering, outfitting and repairing military equipment, and "the construction, maintenance, and repair of buildings, structures, and utilities and the acquisition of real property and interests in real property necessary to carry out the responsibilities specified in this section."
19. JP 3-0, *Joint Operations* (Washington, DC: U.S. GPO, 22 October 2018), V-4.
20. Nicholas R. Simontas, "In Defense of the Theater Army," *Military Review* 97, no. 5 (September-October 2017): 32.
21. Richard M. Swain, *"Lucky War": Third Army in Desert Storm* (Fort Leavenworth, KS: U.S. Army Command and General Staff College Press, 1991); Donald P. Wright and Timothy R. Reese, *On Point II: Transition to the New Campaign* (Fort Leavenworth, KS: Combat Studies Institute Press, 30 June 2008).
22. Field Manual (FM) 3-94, *Armies, Corps, and Division Operations* (Washington, DC: U.S. GPO, July 2021), 3-9.
23. ATP 3-93, *Theater Army Operations*, 2-1-2-2.
24. AR 10-87, *Army Commands, Army Service Component Commands, and Direct Reporting Units*, 2.
25. FM 4-0, *Sustainment Operations* (Washington, DC: U.S. GPO, July 2019), 2-19.
26. Department of Defense, "Welcome to DoD Executive Agent Program," Department of Defense Executive Agents, accessed 29 November 2021, <https://DOD-executiveagent.osd.mil/Agents/Search.aspx?catId=46&psald=46&op=Or>.
27. ATP 3-93, *Theater Army Operations*, 1-3.
28. FM 3-22, *Army Support to Security Cooperation* (Washington, DC: U.S. GPO, January 2013), 3-1.
29. McConville, *Chief of Staff Paper #1*, 16.
30. JP 3-0, *Joint Operations*, VI-3.
31. Tim Devine, "The Theater Army and the Consequence of Landpower for the Indo-Pacific," *Military Review* 101, no. 6 (November-December 2021): 11.
32. "State Partnership Program," U.S. Africa Command, accessed 29 November 2021, <https://www.africom.mil/what-we-do/security-cooperation/state-partnership-program>; "State Partnership Program in Latin America and the Caribbean," U.S. Southern Command, accessed 29 November 2021, <https://www.southcom.mil/Media/Special-Coverage/State-Partnership-Program-in-Latin-America-and-the-Caribbean/>.
33. Mekayla Pierre, "USEUCOM Exercises and Activities Strengthen Unity with Allies and Partners," U.S. European Command, 23 June 2021, accessed 29 November 2021, <https://www.eucom.mil/pressrelease/41395/useucom-exercises-and-activities-strengthen-unity-with-allies-and-partners>.
34. McConville, *Chief of Staff Paper #2*, 19.
35. Robert Martin, "Class of 2022 International Fellows Welcomed to the War College," U.S. Army War College, 6 July 2021, accessed 29 November 2021, <https://www.armywarcollege.edu/News/archives/14094.pdf>.
36. JP 3-20, *Security Cooperation* (Washington, DC: U.S. GPO, 23 May 2017), I-2-I-4.
37. Jen Judson, "Post-Afghanistan, the US Army Wants to Carve out its Role in the Pacific," *Defense News*, 11 October 2021, accessed 29 November 2021, <https://www.defensenews.com/digital-show-dailies/ausa/2021/10/11/post-afghanistan-the-us-army-wants-to-carve-out-its-role-in-the-pacific/>.
38. Leanne Thomas, "U.S. Army South Co-Hosts Second Multilateral Border Security Conference in Manaus," U.S. Army South, 4 October 2021, accessed 29 November 2021, <https://www.arsouth.army.mil/News/Article-Display/Article/2798424/us-army-south-co-hosts-second-multilateral-border-security-conference-in-manau/>.
39. Tim Hanson, "USASAC Leads Charge in Foreign Military Sales for the U.S. Army," *Army.mil*, 25 March 2021, accessed 29 November 2021, [https://www.army.mil/article/244660/usasac\\_leads\\_charge\\_in\\_foreign\\_military\\_sales\\_for\\_the\\_u\\_s\\_army](https://www.army.mil/article/244660/usasac_leads_charge_in_foreign_military_sales_for_the_u_s_army).
40. Michael Hartmayer and John Hansen, "Security Cooperation in Support of Theater Strategy," *Military Review* 93, no. 1 (January-February 2013): 29.

41. H. Clint Kirk IV and Armando Hernandez, "Access to Africa: Setting the Theater for Long-Term Strategic Success," Association of the United States Army, 18 October 2017, accessed 29 November 2021, <https://www.ausa.org/articles/africa-setting-theater-strategic-success>.

42. Joseph John Shimerdla and Ryan Kort, "Setting the Theater: A Definition, Framework, and Rationale for Effective Resourcing at the Theater Army Level," *Military Review* 98, no. 3 (May-June 2018): 61.

43. ATP 3-93, *Theater Army Operations*, 5-4.

44. Lisa M. Litchfield, "USACAPOC(A) and Interoperability in MDO at JWA," U.S. Army Reserve, 4 August 2021, accessed 29 November 2021, <https://www.usar.army.mil/News/Article/2720101/usacapoca-and-interoperability-in-mdo-at-jwa/>.

45. U.S. Joint Chiefs of Staff, *Joint Concept for Operating in the Information Environment (JCOIE)* (Washington, DC: U.S. Joint Chiefs of Staff, 25 July 2018), vii-ix.

46. McConville, *Chief of Staff Paper #1*, 12.

47. Sydney J. Freedberg Jr., "Army's Multi-Domain Unit 'A Game-Changer' in Future War," *Breaking Defense*, 1 April 2019, accessed 29 November 2021, <https://breakingdefense.com/2019/04/armys-multi-domain-unit-a-game-changer-in-future-war/>.

48. ATP 3-93, *Theater Army Operations*, 5-5.

49. "1st Theater Sustainment Command: First Team!," 1st Theater Sustainment Command, 21 November 2017, accessed 29 November 2021, <https://www.1tsc.army.mil/Portals/35/documents/20171121%20-%201st%20TSC%20Fact%20Sheet%20One%20page.pdf?ver=2018-07-26-143643-780>.

50. Ibid.

51. ATP 3-93, *Theater Army Operations*, B-1.

52. Joint Staff J-7 Joint and Coalition Operational Analysis (JCOA), *Operation United Assistance: The DOD Response to Ebola in West Africa* (Suffolk, VA: Joint Staff J-7 JCOA, 6 January 2016), 6, accessed 7 December 2021, [https://www.jcs.mil/Portals/36/Documents/Doctrine/ebola/OUA\\_report\\_jan2016.pdf](https://www.jcs.mil/Portals/36/Documents/Doctrine/ebola/OUA_report_jan2016.pdf).

53. Ashley Dotson, "US Army South Prepares for Hurricane Season," Army.mil, 16 August 2020, accessed 29 November 2021, [https://www.army.mil/article/238181/us\\_army\\_south\\_prepares\\_for\\_hurricane\\_season](https://www.army.mil/article/238181/us_army_south_prepares_for_hurricane_season).

54. Lauren Padden, "ARNORTH Concludes Military Wildland Fire Ground Response Operation in California," U.S. Army North, 29 September 2021, accessed 29 November 2021, <https://www.arnorth.army.mil/Media/News/Article/2792941/arnorth-concludes-military-wild-land-fire-ground-response-operation-in-california/>.

55. McConville, *Chief of Staff Paper #2*, 17.



## FUTURE WARFARE WRITING PROGRAM

### Call for Speculative Essays and Short Works of Fiction

*Military Review* calls for short works of fiction for inclusion in the Army University Press Future Warfare Writing Program (FWWP). The purpose of this program is to solicit serious contemplation of possible future scenarios through the medium of fiction in order to anticipate future security requirements. As a result, well-written works of fiction in short-story format with new and fresh insights into the character of possible future martial conflicts and domestic unrest are of special interest. Detailed guidance related to the character of such fiction together with submission guidelines can be found at <https://www.armyupress.army.mil/Special-Topics/Future-Warfare-Writing-Program/Future-Warfare-Writing-Program-Submission-Guidelines/>. To read previously published FWWP submissions, visit <https://www.armyupress.army.mil/Special-Topics/Future-Warfare-Writing-Program/>.



An Apache helicopter takes off at Michael Army Airfield, Dugway Proving Ground, Utah, on 22 September 2011 as a Shadow unmanned aircraft is readied for its flight onto the battlefield. The two aircraft were involved in a manned-unmanned teaming demonstration known as the Manned Unmanned System Integration Capability activities. (Photo courtesy of the U.S. Army)

# Kicking the Beehive

## Reimagining Manned-Unmanned Teaming in Multi-Domain Operations

Capt. Clayton B. Jaksha, U.S. Army

Technology is not going to limit our ability to compete in multi-domain operations (MDO)—humans will. Although the human brain is skilled at learning and adapting, existing schemas and systems tend to constrain our otherwise unlimited imagination. For Army aviation to compete in MDO, we must refrain from allowing our perceptions of current aircraft, technologies, and tactics to muddy our vision of future employment techniques. U.S. Army Training and Doctrine Command (TRADOC) has identified five key tasks to succeed in MDO against antiaccess/area denial (A2/AD) adversaries: compete, penetrate, dis-integrate, exploit, and re-compete.<sup>1</sup> Army aviation's principal challenge will be operating in highly contested airspace and gaining the requisite situational understanding to execute effective cross-domain maneuver.<sup>2</sup> Manned-unmanned teaming (MUM-T) between manned aircraft and unmanned aircraft systems (UAS) will be decisive for Army aviation to penetrate, dis-integrate, and exploit the enemy, but MUM-T in its current form is unable to conduct cross-domain maneuver effectively. MUM-T will only be effective in MDO after a materiel shift to swarming systems, the embrace of artificial intelligence in mission command and targeting processes, and the reorganization into multi-domain formations at the platoon level.

Presently, Army aviation defines MUM-T as “the integrated maneuver of Army Aviation [rotary wing] and UAS to conduct movement to contact, attack, reconnaissance, and security tasks,” stove-piping its definition by participating systems and functional tasks.<sup>3</sup> While defining the term, doctrine writers envisioned an AH-64E and an MQ-1C or RQ-7B working in tandem through various levels of interoperability (LOI). Early in UAS development, NATO recognized that nascent UAS integration required standardization across the NATO battlespace. NATO Standardization Agreement (STANAG) 4586 gave rise to the definitions of LOI 1-5, which the Army embraced in its own MUM-T doctrine.<sup>4</sup> Each LOI represents an increasing level of integration and interoperability between one UAS and one manned rotary wing platform, going so far as allowing the manned aircraft to take control of the payload or flightpath of the UA (unmanned aircraft, LOIs 4 and 5).

By definition, the LOI framework limits MUM-T to two systems: manned and unmanned. Furthermore, greater LOIs actually remove combat power from

the fight. When an AH-64E executes LOI 3 or 4, the copilot-gunner has to abandon his or her own sights and weapons in order to manipulate the UA's payload, effectively neutralizing the Apache as a weapons platform during MUM-T operations. Meanwhile, the UAS payload operator in the ground control station becomes surplus manpower as the Apache usurps the UA's sensor—it is an inefficient and clumsy use of manpower. Current MUM-T systems and architecture require a redesign for MDO; fortunately, future vertical lift allows for the ground-floor integration of many technologies that will allow Army aviation to compete on the future battlefield.

## Materiel Transformation in Manned-Unmanned Teaming

The substantive materiel changes required for MUM-T in MDO will ultimately need to occur on unmanned aircraft rather than manned aircraft. Manned aircraft must carry humans and are therefore limited in its size, maneuverability, and ability to assume risk. Alternatively, UASs have extraordinary potential for growth. Military UAS development in the preceding decades resulted in large, fixed-wing UASs with expensive sensors, powerful radios, and streamlined air vehicles designed to loiter for long periods over the same geographic location. The counterinsurgency mission drove this perception of UASs as intelligence, surveillance, and reconnaissance platforms, but UASs will take on a new role in MDO. In order to be successful in MDO, the Army must develop fully automated, inexpensive UASs capable of swarm operations.

**Inexpensive and expendable.** Consider the A2/AD integrated air defense threat—large, slow UASs at middle altitudes are prime targets for enemy air defense. Worse yet, the Army's own doctrine often depicts UASs loitering directly over enemy formations, as if the enemy would not attempt to disable or destroy that UAS with kinetic or nonkinetic means.<sup>5</sup> The Army does not possess large quantities of UASs capable of MUM-T and cannot reconstitute them

### Capt. Clayton B.

**Jaksha** is an Army aviator qualified on the AH-64E Apache with operational experience in support of Operation Inherent Resolve and Operation Atlantic Resolve. He holds a BS in electrical engineering from the United States Military Academy.

at a rate that allows commanders to routinely risk their destruction in A2/AD bubbles. The challenge of creating inexpensive and expendable UASs underpins the materiel and mental shift required for MDO. The end state of this paradigm shift is increasing the quantity of UASs by two to three orders of magnitude while decreasing the price per UAS by similar orders of magnitude.

The logistical value of inexpensive, high-quantity UASs is self-evident: commanders risk less by allowing those systems into the A2/AD bubble and the Army can easily reconstitute its losses. The easiest way to begin accomplishing this goal is by decreasing the size of UAs. Using standard Department of Defense terminology, mass-produced, inexpensive UASs for MDO should be group 1 or 2 UASs.<sup>6</sup> Its value goes beyond dollars though—deployed en masse, small UAs conducting swarm operations present a complex tactical dilemma to the enemy and offer friendly forces cover in the A2/AD bubble.

**Swarming.** Recall the opening ceremony of the 2018 Winter Olympics in Pyeongchang: a swarm of 1,200 commercial UAs lit up the sky with dazzling constellations of snowboarders, ice skaters, and curlers.<sup>7</sup> While stunning, the display was a wake-up call to the world that intelligent UA swarms are not only feasible but also downright terrifying. UAs capable of swarming can move in front of their manned partner to saturate targeting systems, present myriad dilemmas, and overwhelm the enemy decision-makers. TRADOC recognizes that swarms will act as “protective measures for formations and individual systems, defeating incoming projectiles prior to close protection systems engaging to defeat them.”<sup>8</sup> Put simply, one member of the larger drone swarm is destroyed rather than the protected element. The swarm’s inherently defensive benefits allow for offensive operations by the protected element.

Swarming capitalizes on an underutilized means of defeating radar: physically overwhelming the system. Fundamentally, jamming achieves this effect through electromagnetic means, but it requires a strong emitter and the correct frequency, and it is usually limited to a particular radar system. Even without emitting, UA swarms jam in the physical domain and gum up radar displays by simply moving in large quantities. UA swarms would be the offensive linemen for manned platforms penetrating A2/AD bubble to

attack critical nodes. Integrated air defense elements would not be able to detect an Apache maneuvering behind a cloud of UAs; the deluge of physical targets would dis-integrate the air defense system and create chaos. Beyond its role as air defense fodder, the Army could outfit individual UAs in the swarm with a variety of low-cost sensors; this creates a shield that simultaneously defends against threats while collecting on those same threats. As swarm technology develops, it will disrupt air defense technology and doom current systems to obsolescence. Leveraging UA swarms and MUM-T, brazen overtness might be the key to penetrating the A2/AD bubble.

**Human augmentation and autonomy.** A major issue with extant MUM-T is the inefficient use of human capital in system employment. MUM-T in MDO must not seek to remove human input, but rather augment human judgment and automate anything that does not require a human decision. Current LOIs relegate MUM-T to controlling the UA’s flight path and its sensor point-of-interest, but that level of control is unwieldy in MDO. Imagine a small UA swarm and the impossible task of controlling each aircraft’s flight path and payload operation. Even for an operator on the ground whose sole task is to manage the swarm, it would be impossible. Instead, the swarm must possess a certain amount of autonomy to control its own flight path and payload utilization. The human should command broader tactics and priorities to the UA swarm. The swarm then seeks human only input when it requires a decision or acquires critical information about the operational environment.

Ultimately, TRADOC already views “swarms of massed, low-cost, self-organizing unmanned systems directed by bi-mimetic algorithms to overwhelm opponents [as a viable] alternative to expensive, exquisite systems.”<sup>9</sup> However, swarms will not entirely replace large UASs; systems like the MQ-1C will still have a place in MDO. Larger UASs will need to perform network management and host heavier, more sophisticated payloads. MUM-T relies on teaming and integrating manned, unmanned, and autonomous systems into the team. Automated systems of systems like UA swarms will be tools to aid systems with humans “in the loop.” The human provides irreplaceable tactical, operational, and ethical judgment; the UA swarm exists to augment the power of human decision.

## Manned-Unmanned Teaming Effects and Targeting Doctrine

MDO engagements require proficient, practiced dynamic targeting techniques to maintain tempo. Contemporary dynamic targeting doctrine (find, fix, track, target, engage, assess) requires extensive human input throughout the targeting loop.<sup>10</sup> This is for good reason—the decision to allocate resources, determine effects, and ultimately kill requires intense situational understanding and informed judgment. However, staff meetings, briefings, and committee decision-making bungle up the process and slow the targeting cycle. In MDO, the viscosity of human interference will allow certain targets to escape the grasp of our effects. Targeting doctrine does not require substantive change, but MDO will force the existing process to accelerate. Commanders in MDO must leverage technological augmentation to rapidly destroy high priority targets. Future targeting operations require fused sensor networks that intelligently pair shooters with targets to deliver cross-domain effects.<sup>11</sup> MUM-T between unmanned sensor swarms and attack helicopters allows for a cross-domain sensor-to-shooter network organic to Army aviation.

**Fused collection.** TRADOC already recognizes that “targeting [will employ] fused sensor data” to enable “friendly units operating dispersed to see and fight over wide areas.”<sup>12</sup> The concept of distributed battlefield sensors is far from novel, but the Army has never deployed them on the scale or density that MDO requires. Furthermore, the preceding decades of counterinsurgency have trained leaders to consider full motion video (FMV) the gold-standard intelligence requirement for targeting. While FMV greatly enhances situational understanding, it also requires sensor line-of-sight and devours bandwidth—both of which are dangerous and untenable in MDO. In order to leverage the power of distributed UA sensor swarms, the Army must outfit these small UAs with a blend of lightweight, low-power sensors. This is far



[Artist's concept] Army researchers develop a reinforcement learning approach called Hierarchical Reinforcement Learning that will allow swarms of unmanned aerial and ground vehicles to optimally accomplish various missions while minimizing performance uncertainty on the battlefield. (Photo courtesy of the U.S. Army/Shutterstock)

from a pipe dream; TRADOC predicts that “the shrinking size and power requirements of many [electronic sensors] makes them more suitable for employment by remote, robotic, and autonomous systems.”<sup>13</sup> Specifically, airborne networks of direction finding (DF) antennae, ground moving target indicator (GMTI) radar, acoustic sensors, and limited electro-optical/infrared (EO/IR) cameras will provide MUM-T the sensor network for commanders to successfully target in MDO. None of these technologies are new, but their decreased size and proliferation will modernize the finding, fixing, and tracking of dynamic targets with limited human input.

DF systems are already the smallest, lightest, and most mature technology that can be employed by UA swarms. Interestingly, one of DF's first applications was in avionics: automatic direction finders provide bearings to aircraft flying to or from omnidirectional radio beacons on the ground. DF is the process of determining an emitter's location by receiving and processing its signals, analyzing its strength, and providing the user a direction to the emitter. Typically, one DF system will provide only an azimuth; two or more will provide a grid location with increasing levels of confidence. These systems passively detect enemy emissions and

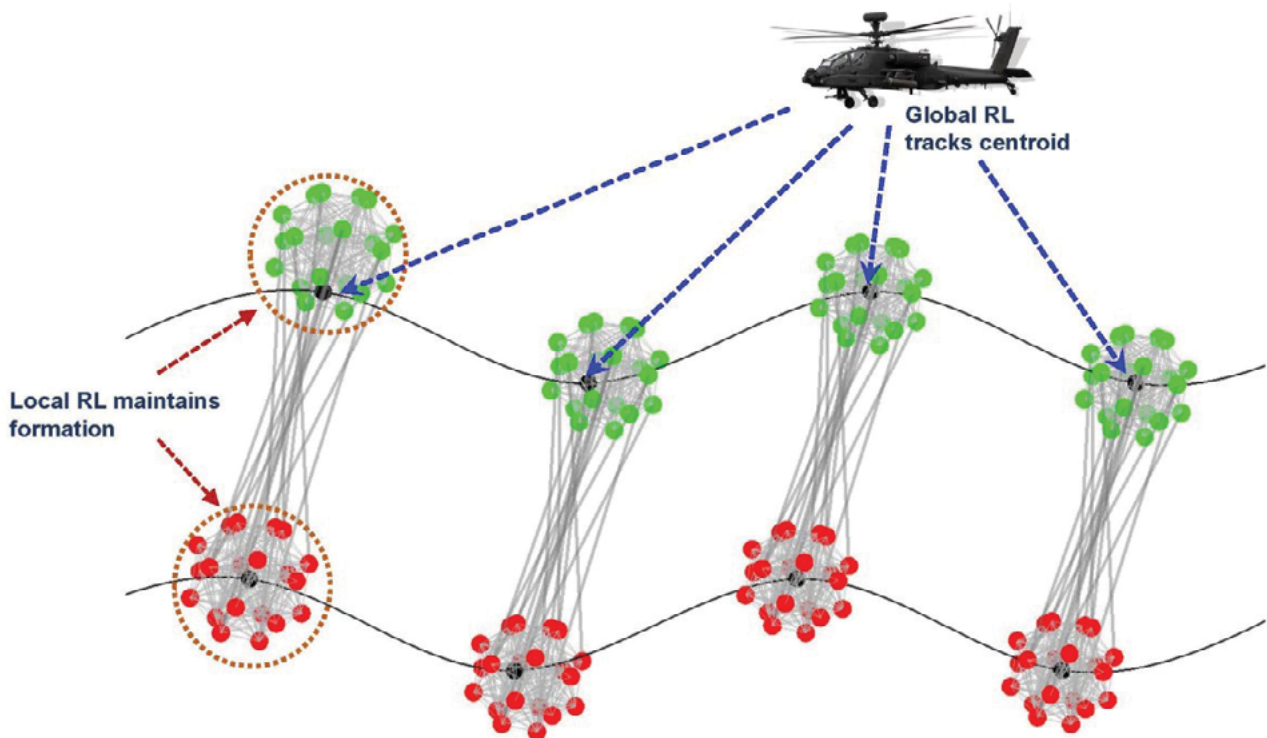

must therefore be widely deployed to generate accurate triangulations. The Army's limited electronic warfare formations today already employ man-portable DF systems.<sup>14</sup> If one-quarter of a UA swarm was equipped with DF systems, then they could quickly pinpoint any emitter on the battlefield and then cue or mix other assets onto that location. DF is a powerful find and fix tool, especially when confirmed by GMTI.

Airborne GMTI systems have traditionally been too large for small UASs; the E-8C Joint Surveillance Target Attack Radar System, a Boeing 707 air vehicle, is the most prolific system. But GMTI is shrinking: the technology recently found a home on the MQ-1C Gray Eagle.<sup>15</sup> As the name implies, GMTI is radar that detects and tracks movement of ground systems. It is a critical link in the find, fix, and track stages, but its price and size will likely limit its employment. Even over the next two decades, GMTI will likely still be limited to larger UASs and a few small UASs. Employed across the MDO battlespace, it could cue other systems to new detections or track high-priority targets before weapons employment. Alone, GMTI provides the manned-unmanned team exceptional sensory reach, but it also requires sensors to defend the team and provide close targets.

Army researchers envision a system of hierarchical control for ground vehicle and air vehicle coordination supported by reinforced learning (RL) that allows swarms of unmanned aerial and ground vehicles to accomplish various missions simultaneously. (Graphic courtesy of the U.S. Army)

Enemies can try to mask their appearance, emissions, and radar cross-sections, but it is far more challenging to mask acoustics. An armored column will sound like an armored column whether it is camouflaged or not. UA swarms could employ sensors similar to those found in anti-helicopter mines, which detect specific acoustic signatures, and use them for close-in targeting.<sup>16</sup> Acoustic sensors are ineffective when mounted on larger airborne platforms due to engine, rotor, and propeller noise, but small UAs present a much quieter noise profile for sensors to overcome. Imagine detecting the characteristic sounds of a T-80 starting or a turret traversing a kilometer away. While that information alone would be inadequate for anything but the find phase of targeting, it could be the first of many fused sensors to collect on that target. Even more, it prevents enemy ground forces from surprising the manned-unmanned team.



Lastly, modern EO/IR systems are already small enough for employment in UA swarms. The gimballed cameras themselves are not a technological limiter, but the challenge of exporting FMV over long distances with low-gain antennae is a problem. Instead of seeking persistent overhead FMV, EO/IR systems should be used in the fix and track phases, using onboard processing to automatically classify and transmit highly compact still images to other nodes in the system. Because commanders ultimately require visual confirmation on certain targets, the Army cannot completely abandon EO/IR in MDO, but reframing its use will free up bandwidth for other targeting data. Fused collection in multiple domains presents multiple dilemmas to the enemy, provides confident targeting data, and feeds smart networks of intelligent manned-unmanned teams.

**Mesh networking.** Distributed airborne sensors collecting fused intelligence is only worthwhile if that data can move somewhere for processing. With the amount of autonomy afforded to future swarms of UAs, we must abandon modern notions of a ground control station with a single high-gain radio datalink to the platform. MUM-T in MDO requires each UA to automatically synchronize with both the swarm's behavior and the manned system's priorities. If every UAS attempted to individually coordinate with the manned platform, it would overload available bandwidth and processing power. Instead, the processing power must be distributed within the swarm and routed throughout the swarm using a form of mesh networking. Mesh networks are dynamic networks with flexible topologies and data pathways—there are no central nodes and the nodes self-organize.<sup>17</sup> In a mesh network, a data packet travels from its sender node to its receiver node by “hopping” between other nodes using adaptive routing algorithms. Modern mesh network technology already allows for deploying sensors on combat vehicles in constant motion where the network topology must “constantly and automatically adapt” to varying distances and terrain.<sup>18</sup> Within a node-dense, highly arrayed swarm of sensors, an individual UAS could share data and process that data in a cloud methodology with the swarm to then provide fused intelligence to the manned platform.

**Artificial intelligence and machine learning.** Artificial intelligence (AI) sounds almost too futuristic to take seriously, but it is the key cognitive augmentation that enables MUM-T in MDO. AI is a type of

computing engineered to process information, reason solutions, and execute action; the process by which AI gains the ability to conduct these executive functions is machine learning. A basic example of machine learning is training software to recognize a face by providing it hundreds of images of that face from different angles, aspects, and lighting conditions and then asking it to use AI to pick that face from FMV of a crowd of people.<sup>19</sup> AI automatically classifying targets from still images and videos has readily apparent military value, but that application is hardly the cross-domain maneuver required for success in MDO.

When well-trained, the speed of AI's analytical and predictive capabilities makes it lethal on the battlefield. Incorporating AI into dynamic targeting doctrine will allow it to predict enemy behavior and pair targets with strike platforms and munitions. The Army is already testing the validity of incorporating AI into deep area strikes, and that technology could be expanded into MUM-T.<sup>20</sup> AI could process fused intelligence collected by a UA swarm and then provide manned attack aircraft target locations, velocities, recommended weaponeering, and simultaneous engagement cueing. Pairing AI with Single Multi-Mission Attack Missiles will empower AI to mass effects on an unsuspecting enemy with a proportionally small friendly force.<sup>21</sup> Incorporating AI into dynamic targeting is about flipping the doctrinal paradigm of automation: instead of humans cueing machines onto targets, machines should be cueing humans to targeting decisions. TRADOC envisions decision cycles accelerated “with AI-enabled intelligence conducting collection ... freeing up warfighters to do what they excel at—fight and make decisions.”<sup>22</sup> The manned platform acts as the quarterback, managing by exception: information flows to the human in the loop. The fundamental change to targeting doctrine is not the process, but rather who—or what—accomplishes each step.

## Multi-Domain Formations and MUM-T Employment Vignettes

The materiel and doctrinal changes engendered by MDO necessitate marked reorganization of MUM-T formations. One of TRADOC's three tenets to succeed in MDO is the employment of multi-domain formations—those combat formations that have the ability to “conduct independent maneuver, employ cross-domain fires, and maximize human potential.”<sup>23</sup> Correctly

organized, Army aviation can leverage MUM-T to generate cross-domain formations at the platoon level. Modern air cavalry squadrons are currently the most integrated MUM-T formation in Army aviation; each line troop possesses eight AH-64 Apaches and four RQ-7 Shadows.<sup>24</sup> However, fighting as a cross-domain formation requires UASs to be organic not just to air cavalry troop, but the air cavalry platoon. Platoons will be the functional unit fighting together on the multi-domain battlefield, not troops. Manned reconnaissance and attack platforms must regularly train and fight with its own organic UA swarms. This will enhance the manned team's trust in the unmanned team and also better inform the AI of the unmanned systems.

Compact, organic MUM-T formations are a powerful tool in MDO because they complement dichotomies unique to the new operational environment. TRADOC identifies four dipoles that frame the changing character of warfare, two of them are particularly relevant to MUM-T: "finders vs. hiders" and "strikers vs. shielders."<sup>25</sup> Manned attack platforms will be hiders, easily detectable and susceptible to lethal and nonlethal engagements, but they will also be strikers, capable of delivering lethal ordnance with direct or indirect fire. Meanwhile, a UA swarm equipped with distributed sensors is an excellent finder and a shielder, protecting manned platforms by maneuvering in front of them or along its flanks. Therefore, a multi-domain platoon-sized element organic to Army aviation would be capable of spanning the spectrum of operations in a changing warfare environment. The following vignettes demonstrate the power of the multi-domain platoon as Army aviation penetrates A2/AD bubbles.

**Vignette 1: Finders and strikers.** An air cavalry platoon executes a movement to contact into an A2/AD bubble. An enemy air defense radar emits in a search pattern as part of an integrated air defense network. The UA swarm ahead of the manned attack team uses DF to calculate an approximate location of the system. A Group 4 UA overhead stares at the grid with EO/IR and conducts an AI-powered search trained to hunt for integrated air defense nodes with AI. After determining the location of its command and control, power generation, radar, and missile sites, the large UAS assigns targets to organic manned attack helicopters, long-range fires, and participating joint platforms. The AI then presents the strike package to the battlespace commander's main

command post. Upon approval, the strike platforms utilize multiple simultaneous engagement technologies like Single Multi-Mission Attack Missiles to dis-integrate and penetrate the air defense network.

**Vignette 2: Shielding against electronic warfare.** Similar to the first vignette, a UA swarm detects an air defense radar through fused collection methods. Only this time, the enemy employs its electronic warfare capabilities and turns on jammers in the vicinity of the swarm. This disables a sizable portion of the swarm, but the majority are out of range of the jammer, are able to sense the threat, and reposition. Because the UA swarm operates on a mesh network topology, it is able to reorganize and reconfigure while providing early warning to the manned platform behind the swarm. Using AI, the network of unmanned airborne sensors analyses the jamming signal, assigns strikers, and awaits the command to engage from a human with decisional authority.

**Vignette 3: The human factor.** A Group 4 UAS utilizing GMTI detects a cluster of vehicles moving toward friendly forces. The UA swarm leverages DF on enemy chatter to triangulate its position. A large UA conducting ISR automatically slews EO/IR to position and, via AI, classifies the image as a large quantity of technical vehicles. Target confidence, rate and direction of march, and size of force triggers a target handover to a manned attack helicopter. The manned asset views the imagery and recognizes that the vehicles are pickup trucks carrying refugees away from the battle zone. The manned asset applies judgment, rejects the targeting package, and ensures they pass safely.

## Conclusion

The materiel advancement required for MUM-T to succeed in MDO seems like science fiction, but that advancement is the product of technologies that already exist. Though the UA swarm seems far-fetched, all signs point to its possibility and potential. The Army is already researching methods for future vertical lift aircraft to manage three or more UASs at a time.<sup>26</sup> Incremental technological advances will march on, but Army aviation must not allow its doctrine and its formations to lag behind as MUM-T develops. The community of Army aviators must learn to embrace the unmanned half of MUM-T and find ways to make the team tactically sound while MUM-T transitions to MDO.

Perhaps the greatest challenge to developing future MUM-T will be the psychological shift necessary to trust an increasingly intelligent unmanned partner. Trusting UASs will be uncomfortable and, much like its enabling technology, will require incremental change. Long before aviators kick the beehive and loose a UA swarm on the battlefield, aviators must build trust with their unmanned systems through regular training. Army aviation today must saddle UASs with increasing responsibility and build its relationship with manned aircraft by demonstrating competence in collective, live-fire training. Ignoring

MUM-T training today corrodes the trust that future formations will require in MDO. Therefore, Army aviation's ability to compete with MUM-T in MDO hinges decisively on its ability to train with MUM-T now. Whether out of inconvenience, frustration, or indolence, the decision to abandon MUM-T today is a decision to fail at MUM-T in MDO. The technology will be ready soon—we cannot limit ourselves. ■

*The opinions expressed herein are the author's alone and are not the opinions of the U.S. Army or the Department of Defense.*

## Notes

1. U.S. Army Training and Doctrine Command (TRADOC) Pamphlet (TP) 525-3-1, *The U.S. Army in Multi-Domain Operations, 2028* (Fort Eustis, VA: TRADOC, 2018), viii–ix.
2. TP 525-3-6, *The U.S. Army Functional Concept for Movement and Maneuver, 2020-2040* (Fort Eustis, VA: TRADOC, 2017), 28.
3. Field Manual (FM) 3-04, *Army Aviation* (Washington, DC: U.S. Government Publishing Office [GPO], 2020), 1-3.
4. Mário Monteiro Marquez, *Standard Interfaces of UAV Control System (UCS) for NATO UAV Interoperability*, Standardization Agreement 4586 (Brussels: NATO, 2017), accessed 15 September 2021, <https://www.sto.nato.int/publications/STO%20Education-ai%20Notes/STO-EN-SCI-271/EN-SCI-271-03.pdf>.
5. Army Techniques Publication (ATP) 3-04.1, *Aviation Tactical Employment* (Washington, DC: U.S. GPO, 2021), 7-25.
6. "Classification of the Unmanned Aerial Systems," Geospatial Applications of Unmanned Aerial Systems (UAS), Pennsylvania State University, table 1, accessed 15 September 2021, <https://www.e-education.psu.edu/geog892/node/5>.
7. Dan Parsons, "Olympic Drone Swarm Heightens Army Concerns over Air Defense," *Defense Daily*, 3 April 2018, accessed 15 September 2021, <https://www.defensedaily.com/olympics-drone-swarm-heightens-army-concerns-air-defense/army/>.
8. TP 525-3-6, *The U.S. Army Functional Concept for Movement and Maneuver*, 40.
9. TP 525-92, *The Operational Environment and the Changing Character of Warfare* (Fort Eustis, VA: TRADOC, 2019), 20.
10. ATP 3-60.1, *Dynamic Targeting* (Washington, DC: U.S. GPO, 2015), 35–43.
11. TP 525-3-4, *The U.S. Army Functional Concept for Fires, 2020-2040* (Fort Eustis, VA: TRADOC, 2017), 9.
12. *Ibid.*, 10.
13. TP 525-8-6, *The U.S. Army Functional Concept for Cyberspace and Electronic Warfare Operations, 2025-2040* (Fort Eustis, VA: TRADOC, 2018), 11.
14. Armando Limon, "Electronic Warfare Soldiers Train with Radio Direction Finding System," *Army.mil*, 11 April 2018, accessed 15 September 2021, <https://www.army.mil/article/203723/electronic-warfare-soldiers-train-with-radio-direction-finding-system>.
15. Jen Judson, "General Atomics Demos Gray Eagle's Role in Multidomain Ops," *Defense News*, 22 January 2020, accessed 15 September 2021, <https://www.defensenews.com/land/2020/01/22/general-atomics-demos-gray-eagles-role-in-multidomain-ops/>.
16. Nikolai Litovkin, "Russian Army to Be Beefed Up with Anti-Chopper Mines," *Russia Beyond*, 25 July 2017, accessed 15 September 2021, [https://www.rbth.com/defence/2017/07/25/russian-army-to-be-beefed-up-with-anti-chopper-mines\\_810775](https://www.rbth.com/defence/2017/07/25/russian-army-to-be-beefed-up-with-anti-chopper-mines_810775).
17. "Introduction to Mesh Networks," *Airberry*, 6 May 2012, [https://web.archive.org/web/20130811032810/http://airberry.com/downloads/airberry\\_Whitepaper\\_EN\\_02\\_Wireless\\_Mesh.pdf](https://web.archive.org/web/20130811032810/http://airberry.com/downloads/airberry_Whitepaper_EN_02_Wireless_Mesh.pdf).
18. *First, Second and Third Generation Mesh Architectures* (Santa Clara, CA: Mesh Dynamics, 2005), accessed 15 September 2021, <https://www.meshdynamics.com/documents/MDThirdGenerationMesh.pdf>.
19. Rafia, "Artificial Intelligence (AI) Image Recognition," *Logicai*, 3 August 2020, accessed 15 September 2021, <https://logicai.io/blog/using-artificial-intelligence-ai-image-recognition>.
20. Nathan Strout, "How the Army Plans to Use Space and Artificial Intelligence to Hit Deep Targets Quickly," *Defense News*, 5 August 2020, accessed 15 September 2021, <https://www.defensenews.com/digital-show-dailies/smd/2020/08/05/how-the-army-plans-to-use-space-and-artificial-intelligence-to-hit-deep-targets-quickly>.
21. Spencer Hudson and Shannon Haataja, "Survive and Project Indirect Fires," *Army.mil*, 8 February 2018, accessed 15 September 2021, [https://www.army.mil/article/200241/survive\\_and\\_project\\_indirect\\_fires](https://www.army.mil/article/200241/survive_and_project_indirect_fires).
22. TP 525-92, *The Operational Environment and the Changing Character of Warfare*, 20.
23. TP 525-3-1, *The U.S. Army in Multi-Domain Operations*, 19.
24. FM 3-04, *Army Aviation*, 2-8.
25. TP 525-92, *The Operational Environment and the Changing Character of Warfare*, 19.
26. Grant Taylor and Terry Turpin, "Army Aviation Manned-Unmanned Teaming (MUM-T): Past, Present, and Future," *18th International Symposium on Aviation Psychology* (2015): 564–65, accessed 15 September 2021, [https://corescholar.libraries.wright.edu/cgi/viewcontent.cgi?article=1095&context=isap\\_2015](https://corescholar.libraries.wright.edu/cgi/viewcontent.cgi?article=1095&context=isap_2015).



Pfc. Brandon Norton, an M1 Abrams crewmember with Company B, 1st Battalion, 63rd Armor Regiment, 2nd Armored Brigade Combat Team, 1st Infantry Division, launches a Lethal Miniature Aerial Missile System 6 April 2018 for aerial support during a Robotic Complex Breach Concept assessment and demonstration at Grafenwoehr, Germany. According to widely publicized press accounts in March 2022, the United States has provided a hundred such lethal loitering munitions to Ukraine. The individual launched drones have been described as the equivalent of individual cruise missiles that identify and then attack targets with a powerful fragmentation charge, exploding on contact. Unlike other types of indirect fires, the drones have proved very effective in attacking targets located in narrow or confined spaces with pinpoint accuracy. The drones are light weight and relatively inexpensive compared to other types of fires weapons. (Photo by Sgt. Gregory T. Summers, 22nd Mobile Public Affairs Detachment)

# How to Keep Changing an Army

## Adjusting Modernization in the Age of Loitering Munitions

Maj. Ryan Orsini, U.S. Army

Somewhere along the Second Island Chain, 2028:

*“What’s the status of waves one and two?” asked an exasperated Lt. Col. Smith. With his small battalion task force still stretched across the airfield, only this question mattered. From under a poncho came a reply, “Sir, wave one has four rounds and eight high-payoff targets remaining, and wave two will be up in eight mikes.” Wave one consisted of twenty-four air-launched loitering munitions during the unit’s SEAD [suppression of enemy air defenses] mission. Somewhere in the dark, his paratroopers frantically derigged two all-terrain vehicles from the heavy drop to get wave two in the air, consisting of sixteen more ground-launched loitering munitions. No one reported joint assets available—there were none. Smith’s team was on its own. Serving collection, strike, and protection roles, the loitering munitions were his eyes, ears, fists, and life jacket. Smith started the timer on his wristwatch—wave two could provide up to eight hours of cover.*

*Smith marveled at how this type of operation unfolded just twenty years ago. Back then, joint force assets would hover over the lodgment until OH-58 Kiowa helicopters could be airlanded, unfolded, and sent airborne. That aircraft was long gone, and so too were the joint forces to protect his team. Joint assets that secured a window for his airborne assault were now focused twenty miles north of his position, supporting a Marine littoral regiment raid elsewhere on the second island chain. If Smith could secure this lodgment, two more C-17s would airland a multi-domain task force strategic fires element. Time was of the essence. Wave two needed to get in the air. Smith thought of B. H. Liddell Hart’s quote about military innovation: “The only thing harder than getting a new idea into the military mind is to get an old one out.”<sup>1</sup> Casualties were mounting, and the outcome far from certain, but Smith knew the Army got this change right.*

**F**orty years ago, as U.S. Army Gen. Donn Starry looked back at the last ten years of U.S. Army modernization post-Vietnam, he saw that the only constant was the need for change itself.<sup>2</sup> The signature conflict of the 1970s, the 1973 Yom Kippur War, pitted two peer militaries in a ground fight using technology and tactics similar to those planned for a U.S.-Soviet fight in Europe. The conflict did not initiate modernization—the post-Vietnam force generated that awakening. Rather, it served as an inflection point of iterative innovation that eventually yielded the Big Five

technology and AirLand Battle concept that fueled U.S. military success until today.<sup>3</sup>

The 2020 Nagorno-Karabakh war is another inflection point for U.S. military adaptation. The conflict provided the next snapshot of war’s changing character toward faster and more lethal forms of stand-off.<sup>4</sup> Azerbaijani unmanned platforms, particularly loitering munitions, effectively established aerial dominance that enabled massed ground maneuver. These lessons should not be dismissed due to the relative status of the combatants. The improving technology and tactics of massed loitering munitions in the hands of more formidable adversaries could dominate a future battlefield.<sup>5</sup>

The task ahead of the U.S. Army today is not to bring about a change effort—its modernization program began years ago. Rather, it is to pivot ongoing programs. Military adaptation is both relative and dynamic—the service must keep up with the rate of change for loitering munition employment in the current and future operating environments.<sup>6</sup> The Army must pivot its modernization by adjusting how it organizes, experiments, and trains for change.

## Welcome to the Snow Dome—the Evolution of Loitering Munition Employment

*If we could learn how to change our institutions from within instead of creating the circumstances in which change is forced upon us ... The need to change will ever be with us.*

—Gen. Donn Starry<sup>7</sup>

The recent wave of American military modernization centers on one operational problem—the snow dome.<sup>8</sup> Sometimes referred to as an antiaccess/area denial bubble, a snow dome is a temporally and geographically layered combined arms effort in depth to limit an adversary’s maneuver and enable its destruction from a distance. The concept of geographic denial is not new to warfare and consistently evolves over time. This variant uniquely counters U.S. advantages in force projection, decision-making, and strike capabilities.

The first version of the snow dome appeared in earnest in 2014 when two crises rocked the U.S. military establishment: the Russian invasion of Crimea and the Chinese artificial island construction in the South China Sea. Version 1.0, exemplified by Russian

operations in eastern Ukraine, stood out for its ability to use multiple domains to quickly queue lethal surface-to-surface engagements by massed cannon, rocket, and missile fire.<sup>9</sup> Electronic warfare assets and unmanned aerial vehicles enabled Russian battalion tactical groups to destroy Ukrainian formations at great range, unleashing a new effectiveness of their reconnaissance-strike concept. After years of focus elsewhere, U.S. planners could finally envision the reality of peer conflict.

Against Russia, electronic and information attacks could isolate U.S. maneuver units, and massed rocket strikes could annihilate U.S. Army mechanized formations.<sup>10</sup> Against China, the growing People's Liberation Army Rocket Force could sink U.S. Navy ships at a range and scale that the U.S. military could not replicate or reconstitute.<sup>11</sup> The U.S. military has since re-

sponded with its largest modernization effort in decades, focusing on large-scale combat operations (LSCO) with new concept and materiel development such as the U.S. Army's multi-domain operations concept and the U.S. Marine Corps' littoral regiments.<sup>12</sup>

Predictably, the threat has continued

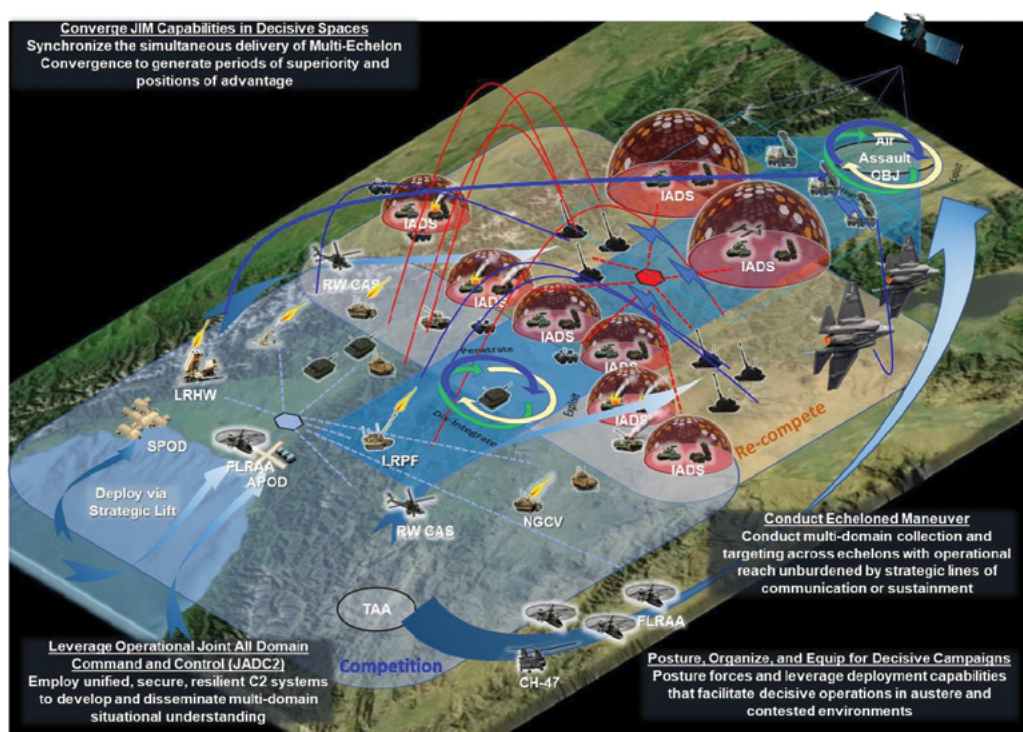

U.S. forces often see future maneuver by neutralizing enemy integrated air defense systems as demarcated with red bubbles above. This graphic fails to capture how our enemy will seek to place similar bubbles, antiaccess/area denial-generated snow domes, over U.S. forces to isolate and defeat them. (Figure from Army Futures Command Pamphlet 71-20-1, *Army Futures Command Concept for Maneuver in Multi-Domain Operations 2028* [7 July 2020]).

to evolve. The Nagorno-Karabakh conflict provides the best example of the snow dome version 2.0, where lethality is predominantly unmanned and aerial-to-surface to dominate multiple domains.<sup>13</sup> Unmanned platforms, specifically the Bayraktar TB2, served as an aerial command-and-control node, linking sensor to shooter for collection, strike, assessment, and exploitation. The emerging centerpiece of this new snow dome is the loitering munition.<sup>14</sup> Sometimes referred to as “kamikaze drones,” these munitions present tremendous operational capability.<sup>15</sup> Tightly integrated with intelligence, surveillance, and reconnaissance capabilities on the battlefield, loitering munitions can be launched well out of contact until queued by manned or unmanned systems for additional reconnaissance or precision strike with various payloads.

While the United States retained unprecedented dominance in manned and unmanned aerial attack capabilities in its post-9/11 wars, other states iteratively tested loitering munitions to complement their own comparative advantages. Houthis targeted Saudi

**Maj. Ryan Orsini, U.S. Army**, is a student at the Command and General Staff College. He holds a Master of Public Policy from Georgetown University. He has served in airborne and air assault units, and deployed in support of Operations Enduring Freedom, Freedom's Sentinel, and Joint Guardian.

Patriot systems in counterinfrastructure missions.<sup>16</sup> Iranian militias employed loitering munitions against U.S. forces in Iraq.<sup>17</sup> Russia struck targets in Syria using domestically produced Lancet loitering munitions.<sup>18</sup> Yet no nation refined the capability for battle like Turkey. Turkey honed techniques in Syria and Libya, earning the moniker of Pantsir-killer, referring to the Russian mainstay point air-defense asset.<sup>19</sup> In Nagorno-Karabakh, the Harop loitering munition, with its one thousand-kilometer range, six hours of endurance, low cross-section, and top attack trajectory deployed in large numbers from mobile launch trucks to obliterate high-priority targets such as air defense, artillery, and armor.<sup>20</sup> Much has been made of deficient Armenian equipment and training, but in truth, no military currently employs sufficient active and passive protection measures to stop the precision, mass, and synchronization loitering munitions bring to the battlefield today.

Loitering munitions will continue to increase the complexity of future battlespaces as both the technology and concepts mature. In the near-term, states will optimize munition lethality by size, payload, and endurance for more effective employment in both the close and the deep fights.<sup>21</sup> Squads and divisions alike will employ variations to facilitate targeting at their level. In the long-term, manned-unmanned teaming will provide unparalleled levels of synchronization, where loitering can queue or complement other assets with various levels of human integration.<sup>22</sup>

These trends lines reveal two challenges for future ground forces. First, mass matters, and units must balance mass with the masking and decentralization required to survive.<sup>23</sup> As units fight dispersed and degraded, loitering munitions must be forward to rapidly achieve effect or to replace lost capability when isolated from the rest of the joint force. Second, offense will be the best defense in a world where the archer is more elusive, arrows more plentiful, and communication links less necessary. Units will need to attrit loitering munitions as a system from logistics to launcher as they will offer redundant targeting capability to the adversary's electronic warfare, intelligence, and fires capabilities. While the services lack consensus on the scale and time horizon of the future threat, they can count on loitering munitions playing an increasing role in future conflict.<sup>24</sup>

## Implications—Risk and Opportunity for U.S. Ground Forces

*Offensive operations, often times, is the surest, if not the only (in some cases) means of defence.*

—George Washington<sup>25</sup>

The loitering munition threat is particularly acute for U.S. ground forces because it overlaps existing and future tactical gaps in sensing, shooting, and protecting. These gaps typically occur between fifty and three hundred kilometers, the depth of the battlefield where U.S. Army divisions are reliant on higher headquarters for critical joint capabilities and authorities.<sup>26</sup> Significant warfighting capability from national intelligence assets and multi-domain task forces to F-35 sorties may not be responsive enough for tactical units, leaving them vulnerable to the organic capabilities of adversaries. In 2017, the U.S. Army Combined Arms Center's LSCO gap study rendered a similar conclusion, revealing a wide gap in cannon, rocket, and missile strike and protection capability.<sup>27</sup> Tactical units at the division and below must be able to sense and shoot to keep an adversary's snow dome from quickly falling on them, particularly when dispersed, degraded, and separated from the larger joint force or otherwise risk isolation and defeat in detail.

On the other hand, loitering munitions provide incredible opportunity to mitigate the U.S. Army's operational and modernization weaknesses and generate adversary dilemmas. First, the range and endurance of today's munitions would provide much needed tactical flexibility to the ground component, mitigating the sense, shoot, and protect gap between division and corps with an asymmetric, top-attack capability. This massed and synchronized surface-to-surface fire is essential to take down the snow dome for either ground maneuver or as ground force support to the joint force.<sup>28</sup> Second, this capability provides ground forces the ability to degrade gracefully, meaning they can operate with limited functionality in denied and degraded space and cyberspace environments. As a result, units can not only fight cut off but also use unmanned systems to provide cross-domain data solutions for others in contested environments.<sup>29</sup> Finally, a decentralized loitering munition capability provides escalation flexibility.<sup>30</sup> Overreliance on precise, expensive, and centralized capability, such as the emerging hypersonic capability, might be too limited in quantity



Multiple Azerbaijani unmanned aerial vehicles circle over a reported strike against Armenian military forces 1 October 2020 during the Second Nagorno-Karabakh conflict. (Photo courtesy of the Azerbaijan Defense Ministry)

and authority to sustain necessary mass in the opening phases of conflict. Such flexibility is especially important early on in LSCO when mass and reconstitution are critical components of victory.

## Recommendations—How to Keep Changing an Army

*Change requires institutional, organizational, and conceptual momentum towards shedding those practices or platforms which are no longer relevant.*

—Gen. James McConville<sup>31</sup>

The services can facilitate a modernization pivot with three interrelated steps to how the services organize, experiment, and train for change. First and foremost, the U.S. Army must elevate loitering munition employment as a critical effort. The U.S. Army's modernization priorities are colloquially known as the "31+4," featuring thirty-one signature efforts led by cross-functional teams and four critical efforts led by the Rapid Capabilities and Critical Technologies Office (RCCTO).<sup>32</sup> While these priorities acknowledge gaps in sensing and shooting, they are biased toward transformation of strategic-level assets such as

hypersonic missiles and upgrades at the tactical level including the Army Tactical Missile System replacement and extended range cannon.<sup>33</sup> Recently, RCCTO announced the charter of a midrange capability with the first operational battery in fiscal year 2023.<sup>34</sup> This office should grow around the employment of loitering munitions and consolidate a fifth critical modernization effort.

Second, the services must focus experimentation on loitering munition employment. One of the greatest benefits of service initiatives like Project Convergence, a yearly U.S. Army initiative to collaboratively experiment and scale incipient military technologies, is the emphasis on service member touch points early on in capability development.<sup>35</sup> The U.S. Army should get loitering munition capabilities to U.S. Army divisions and allow them to physically and digitally experiment on optimal employment to provide dispersed mass on the battlefield. Their mandate should include bill-payer strategies for a no-growth environment. For example, a loitering munition battery could replace a howitzer battery in each active-duty field artillery battalion, thereby minimizing overreliance on towed artillery and making use of



the resident fires planning and logistics capabilities of these formations. The U.S. Army can induce competition between the divisional experimentation and the midrange capability by the RCCTO. Further, the U.S. Army can compare its experimentation with the U.S. Marine Corps, which focused loitering munition development not for mass fires, but for long-range reconnaissance and small-unit employment.<sup>36</sup>

Third, a modernization pivot requires changes to training. Time and again, history shows military modernization is more than materiel—just as important are the doctrinal concepts, training, and leadership that implement change.<sup>37</sup> Service experimentation should iterate on the principles of ground-based loitering munition employment, particularly how to balance mass and masking techniques. Finally, leaders must focus self-study on the historical trends of mass attack—such as the nineteenth-century infantry charge, the twentieth-century naval air strike, or the twenty-first-century attack helicopter raid.<sup>38</sup>

## Conclusion—When Pivots Become Normal

*Put simply, militaries and their civilian leaders must believe there is something worse than change.*

—Christian Brose<sup>39</sup>

If no plan survives first contact with an enemy, then surely no modernization plan should be cast in stone. The U.S. Army's modernization plan must be flexible enough for task pivots to become normal. Forty years ago, Starry taught us that innovation is an intensely iterative arena. The 2020 Nagorno-Karabakh conflict can be a famous—or infamous—lesson for all militaries about the future character of war. The next time U.S. ground forces are committed to combat, some version of the snow dome will descend around them. Will they be ready? ■

*The views expressed are those of the author and do not reflect the official position of the Department of the Army or Department of Defense.*

## Notes

1. B. H. Liddell Hart, *Thoughts on War* (London: Faber and Faber, 1944), 115.

2. Donn A. Starry, "To Change an Army," *Military Review* 63, no. 3 (March 1983): 20, accessed 18 November 2021, <https://fromthegreennotebook.com/wp-content/uploads/2019/02/To-Change-and-Army-Starry.pdf>.

3. "Big Five" refers to five major weapon systems that gave the United States a decisive technological advantage when they were introduced in the 1980s: the Abrams main battle tank, the Bradley Fighting Vehicle, the Apache attack helicopter, the Black Hawk utility helicopter, and the Patriot air defense system. "AirLand Battle" was the Army's overarching doctrine in the 1980s and 1990s; it was replaced by "Full-Spectrum Operations."

4. Michael Kofman and Leonid Nersisyan, "The Second Nagorno-Karabakh War, Two Weeks In," *War on the Rocks*, 14 October 2020, accessed 18 November 2021, <https://warontherocks.com/2020/10/the-second-nagorno-karabakh-war-two-weeks-in/>.

5. Alexander Stronell, "Learning the Lessons of Nagorno-Karabakh the Russian Way," International Institute for Strategic Studies, 10 March 2021, accessed 18 November 2021, <https://www.iiss.org/blogs/analysis/2021/03/lessons-of-nagorno-karabakh>.

6. David Barno and Nora Benashel, *Adaptation under Fire: How Militaries Change in Wartime* (Oxford, UK: Oxford University Press, 2020), 9.

7. Starry, "To Change an Army," 27.

8. Brad Marvel, "Shattering the Snow Dome: How Army Ground Forces Can Meaningfully Contribute to Joint Suppression of Enemy Air Defenses," *Military Review* (Online Exclusive, 7 June 2017), accessed 18 November 2021, <https://www.armyupress.army.mil/journals/>

[Military-Review/Online-Exclusive/2017-Online-Exclusive-Articles/Shattering-the-Snow-Dome/](https://www.armyupress.army.mil/journals/Military-Review/Online-Exclusive/2017-Online-Exclusive-Articles/Shattering-the-Snow-Dome/).

9. Amos Fox, "The Russian-Ukrainian War: Understanding the Dust Clouds on the Battlefield," Modern War Institute at West Point, 17 January 2017, accessed 18 November 2021, <https://mwi.usma.edu/russian-ukrainian-war-understanding-dust-clouds-battlefield/>.

10. Brad Marvel, "The Snow Dome, Part 2: Russian Artillery Tactics and Systems," *Red Diamond Threats Newsletter* 8, no. 8, August 2017, 3–8, accessed 18 November 2021, <https://community.apan.org/wg/tradoc-g2/b/weblog/posts/red-diamond-threats-newsletter-august-2017-edition-1417134266?pi296657=6>.

11. Peter W. Singer and Ma Xiu, "What Do We Know About China's Newest Missiles?," *Defense One*, 19 March 2021, accessed 18 November 2021, <https://www.defenseone.com/ideas/2021/03/what-do-we-know-about-chinas-newest-missiles/172782/>.

12. U.S. Army Training and Doctrine Command (TRADOC) Pamphlet 525-3-1, *The U.S. Army in Multi-Domain Operations 2028* (Fort Eustis, VA: TRADOC, 2018), iii; Mallory Shelbourne, "Marine Corps to Stand Up First Marine Littoral Regiments in FY 2022," U.S. Naval Institute, 20 January 2021, accessed 18 November 2021, <https://news.usni.org/2021/01/20/marine-corps-to-stand-up-first-marine-littoral-regiment-in-fy-2022>.

13. "Insights from the Nagorno-Karabakh Conflict in 2020 (Part II)," U.S. Army Mad Scientist Laboratory, 29 March 2021, accessed 18 November 2021, <https://madsciblog.tradoc.army.mil/316-insights-from-the-nagorno-karabakh-conflict-in-2020-part-ii/>.

14. John Antal, "Death from Above: How Secure Tactical Video Transmission Impacted the Second Nagorno-Karabakh War,"

- European Security and Defense, 5 January 2021, accessed 10 September 2021, [https://www.academia.edu/45460690/Death\\_from\\_Above\\_How\\_Secure\\_Tactical\\_Video\\_Transmission\\_Impacted\\_the\\_Second\\_Nagorno\\_Karabakh\\_War](https://www.academia.edu/45460690/Death_from_Above_How_Secure_Tactical_Video_Transmission_Impacted_the_Second_Nagorno_Karabakh_War).
15. Jane Arraf and Eric Schmitt, "Iran's Proxies in Iraq Threaten U.S. With More Sophisticated Weapons," *New York Times* (website), 4 June 2021, accessed 10 September 2021, <https://www.nytimes.com/2021/06/04/world/middleeast/iran-drones-iraq.html>.
16. Ria Kahwaji, "Saudi Air Defense Stops Most Houthi Strikes," *Breaking Defense*, 30 March 2021, accessed 18 November 2021, <https://breakingdefense.com/2021/03/saudi-air-defense-stops-most-houthi-strikes/>.
17. Louisa Loveluck and John Hudson, "Iran-Backed Militias Turn to Drone Attacks, Alarming U.S. Forces in Iraq," *Washington Post* (website), 29 May 2021, accessed 18 November 2021, [https://www.washingtonpost.com/world/middle-east/iraq-militia-drones-threat/2021/05/28/864e44d0-bc8f-11eb-922a-c40c9774bc48\\_story.html](https://www.washingtonpost.com/world/middle-east/iraq-militia-drones-threat/2021/05/28/864e44d0-bc8f-11eb-922a-c40c9774bc48_story.html).
18. Roger McDermott, "Russian UAV Technology and Loitering Munitions," *The Jamestown Foundation*, 5 May 2021, accessed 18 November 2021, <https://jamestown.org/program/russian-uav-technology-and-loitering-munitions/>.
19. Daniel S. Nasereddine, "The Dawn of the Loitering Munitions Era," U.S. Army Mad Scientist Laboratory, 14 June 2021, accessed 18 November 2021, <https://madsciblog.tradoc.army.mil/333-the-dawn-of-the-loitering-munitions-era/>.
20. "Air Defense Systems Hunter: Drone Swarms and Loitering Munitions," *Foreign Military Studies Office OE Watch* 10, no. 11 (November 2020), 43.
21. Paul Iddon, "Turkey, Israel and Iran Have Built Some Very Lethal Loitering Munitions," *Forbes* (website), 19 July 2020, accessed 18 November 2021, <https://www.forbes.com/sites/pauliddon/2020/07/19/turkey-israel-and-iran-have-built-some-very-lethal-loitering-munitions/>.
22. Norine MacDonald and George Howell, "Killing Me Softly: Competition in Artificial Intelligence and Unmanned Aerial Vehicles," *Prism* 8, no. 3 (January 2020): 103–22, accessed 29 November 2021, [https://ndupress.ndu.edu/Portals/68/Documents/prism/prism\\_8-3/prism\\_8-3\\_MacDonald-Howell\\_102-126.pdf](https://ndupress.ndu.edu/Portals/68/Documents/prism/prism_8-3/prism_8-3_MacDonald-Howell_102-126.pdf).
23. John Antal, "Top Attack: Lessons Learned from the Second Nagorno-Karabakh War," U.S. Army Mad Scientist Laboratory, 1 April 2021, accessed 28 December 2021, <https://madsciblog.tradoc.army.mil/317-top-attack-lessons-learned-from-the-second-nagorno-karabakh-war/>.
24. Christopher Dougherty, "Gradually and Then Suddenly: Explaining the Navy's Strategic Bankruptcy," *War on the Rocks*, 30 June 2021, accessed 18 November 2021, <https://warontherocks.com/2021/06/gradually-and-then-suddenly-explaining-the-navy-strategic-bankruptcy/>.
25. George Washington, "From George Washington to John Trumbull, 25 June 1799," National Archives Founders Online, accessed 18 November 2021, <https://founders.archives.gov/documents/Washington/06-04-02-0120>.
26. Robert Mikaloff, "Division Intelligence: Looking Deep to Win Close," in *Large-Scale Operations: The Division Fight*, ed. Dennis Burket (Fort Leavenworth, KS: U.S. Army Command and General Staff College Press, 2019), 73–80.
27. Tisha Swart-Entwistle, "Rainey Takes Command of Combined Arms Center and Fort Leavenworth," Combined Arms Center Public Affairs Office, 17 December 2019, accessed 18 November 2021, [https://www.army.mil/article/231092/rainey\\_takes\\_command\\_of\\_combined\\_arms\\_center\\_and\\_fort\\_leavenworth](https://www.army.mil/article/231092/rainey_takes_command_of_combined_arms_center_and_fort_leavenworth).
28. Marvel, "Shattering the Snow Dome."
29. J. R. Cox et al., *Unmanned Systems in Integrating Cross-Domain Naval Fires* (Monterey, CA: U.S. Naval Postgraduate School, June 2016), accessed 18 November 2021, <https://apps.dtic.mil/sti/pdfs/AD1026818.pdf>.
30. Chris Dougherty, *More than Half the Battle: Information and Command in a New American Way of War* (Washington, DC: Center for New American Security, 20 May 2021), 33, accessed 18 November 2021, <https://s3.amazonaws.com/files.cnas.org/CNAS+Report+Command+and+Info-2021.pdf>.
31. James McConville, *Army Multi-Domain Transformation: Ready to Win in Competition and Conflict*, Chief of Staff Paper No. 1 (Washington, DC: Headquarters, Department of the Army, 16 March 2021), ii, accessed 18 November 2021, <https://api.army.mil/e2/c/downloads/2021/03/23/eeac3d01/20210319-csa-paper-1-signed-print-version.pdf>.
32. Ryan D. McCarthy, James C. McConville, and Michael A. Grinston, "2019 Army Modernization Strategy" (Washington, DC: Department of Defense, 2019), 7, accessed 18 November 2021, [https://www.army.mil/e2/downloads/rv7/2019\\_army\\_modernization\\_strategy\\_final.pdf](https://www.army.mil/e2/downloads/rv7/2019_army_modernization_strategy_final.pdf).
33. Cedric Wins, "RDECOM's Road Map to Modernization the Army: Long-Range Precision Fires," *Army.mil*, 26 September 2018, accessed 18 November 2021, [https://www.army.mil/article/211569/rdecoms\\_road\\_map\\_to\\_modernizing\\_the\\_army\\_long\\_range\\_precision\\_fires](https://www.army.mil/article/211569/rdecoms_road_map_to_modernizing_the_army_long_range_precision_fires).
34. Nancy Jones-Bonbrest, "Mid-Range Capabilities Project Office Assumes New Charter," *Army.mil*, 20 May 2021, accessed 18 November 2021, [https://www.army.mil/article/211569/rdecoms\\_road\\_map\\_to\\_modernizing\\_the\\_army\\_long\\_range\\_precision\\_fires](https://www.army.mil/article/211569/rdecoms_road_map_to_modernizing_the_army_long_range_precision_fires).
35. Thomas Brading, "Army Scales Up Joint Capabilities as Project Convergence Grows," *Army.mil*, 12 February 2021, accessed 18 November 2021, [https://www.army.mil/article/243255/army\\_scales\\_up\\_joint\\_capabilities\\_as\\_project\\_convergence\\_grows](https://www.army.mil/article/243255/army_scales_up_joint_capabilities_as_project_convergence_grows).
36. Joseph Trevithick, "Marines Pick Loitering Munition to Arm Light Vehicles and Drone Boats," *The Drive*, 23 June 2021, accessed 18 November 2021, <https://www.thedrive.com/the-war-zone/41219/marines-pick-loitering-munition-to-arm-light-vehicles-and-drone-boats>; David Larter, "The US Marine Corps Wants Grunts Packing Deadly Swarming Drones," *Defense News* (website), 9 December 2020, accessed 18 November 2021, <https://www.defensenews.com/naval/2020/12/09/the-us-marine-corps-wants-grunts-packing-deadly-swarming-drones/>.
37. Ian Sullivan, "Once More Unto the Breach Dear Friends: From English Longbows to Azerbaijani Drones, Army Modernization Still Means More than Materiel," U.S. Army Mad Scientist Laboratory, 28 January 2021, accessed 18 November 2021, <https://madsciblog.tradoc.army.mil/300-once-more-unto-the-breach-dear-friends-from-english-longbows-to-azerbaijani-drones-army-modernization-still-means-more-than-materiel/>.
38. Michael Shaara, *The Killer Angels: The Classic Novel of the Civil War* (New York: Ballantine Books, 1987); Gordon Prange, *Miracle at Midway* (New York: Penguin, 1982); Rick Atkinson, *In the Company of Soldiers: A Chronicle of Combat* (New York: Henry Holt, 2004).
39. Christian Brose, *The Kill Chain: Defending America in the Future of High-Tech Warfare* (New York: Hachette, 2020), 85.

# The Tactical Considerations of Augmented and Mixed Reality Implementation

Dr. Jan Kallberg

Maj. Victor Beitelman, U.S. Army

Maj. Victor Mitsuoka, U.S. Army

Chief Warrant Officer 3 Jeremiah Pittman, U.S. Army

Dr. Michael W. Boyce

Lt. Col. Todd W. Arnold, U.S. Army

**T**he U.S. Army, NATO armies, and other advanced nations actively seek to implement augmented reality (AR) and mixed reality (MR) support for their operational forces. These platforms are intended to improve tactical awareness, target acquisition, and situational awareness, and also to develop an information upstream for commanders to act upon.

The United States' example is the integrated visual augmentation system (IVAS), which provides an integrated suite of situational awareness capabilities to enable better decision-making and increase soldier tactical fighting ability.<sup>1</sup> In the light of rapid developments and hurdles faced in fielding for the United States and its allies, we would like to add to the Army discourse

the need to identify potential operational weaknesses in the AR/MR systems. The operational environment will test any equipment's durability and reliability. A central question we investigate is the tactical value on the battlefield and whether the system losing full or partial functionality changes the system from a capability enhancement into something that obstructs or prevents mission success. We identify multiple areas and research topics for investigation in order for AR devices to become a combat multiplier.

The acquisition and fielding process for new Army technology has shifted from an eight-to-ten-year process down to thirty-six months for delivery due to the availability of commercial platforms.<sup>2</sup> The condensed



A soldier tests the Capability Set 3 militarized form factor prototype of the Army's Integrated Visual Augmentation System 21 October 2020 during a live-fire test event at its third Soldier Touchpoint at Fort Pickett, Virginia. (Photo by Courtney Bacon)

process—soldier-centered design (SCD)—is different from traditional acquisition processes such that it meets the needs of rapidly evolving technology. This is evident in the Army's efforts to mature technological products to the soldier in a twelve-month period of performance via the rapid innovation fund, which is a significantly shorter time frame compared to earlier technology deployments.<sup>3</sup> Rapid acquisition and deployment meet the demand for bringing the latest technology to the soldiers but with quick turnaround comes also the risk of embedding weaknesses that are not identified early in the process. The challenge in the research and development of these technologies is to follow a methodological approach that allows for the imperfection and experimentation of technology, a concept that is new in Army capability development.

Via the IVAS program, AR/MR is positioned to be the next integrated battlefield technology. The U.S. Army is placing a considerable amount of investment and capital—human, financial, and temporal—into its

refinement and deployment while purchasing 120,000 headsets to field to the force.<sup>4</sup> Currently, IVAS prototypes are rolling out to larger user bases to evaluate effectiveness with different populations and echelons.

While early adoption of AR/MR is promising, integrating technology into military operations inevitably encounters challenges. In a 2020 article on the Army's synthetic training environment, augmented reality, cybersecurity, rendering data, and bandwidth and latency were all identified as key challenges facing the Army for training.<sup>5</sup> This work expands the existing literature to focus on visualizing uncertainty on the battlefield, as well as to address some of the already identified shortcomings of using augmented displays for military operations.<sup>6</sup>

Integrating new technologies into combat operations requires multiple testing and refinement iterations via SCD. SCD focuses on feedback from soldiers and is prioritized in the development of feature sets. Recent soldier evaluations using the Army's IVAS has shown the importance of gaining bottom-up

requirements analysis to improve soldier operations and utility.<sup>7</sup> The combat force lauds the testing, implementation, and fielding of AR/MR systems, in particular IVAS. The IVAS system has reportedly collected eighty thousand hours of feedback, been tested in extreme weather conditions in Alaska and Puerto Rico, and has a suite of capabilities to include thermal imaging, integrated GPS, night vision, holographic maps, and the ability to see around corners using a weapon's sight.<sup>8</sup> The IVAS is based on Microsoft's HoloLens 2, and despite undergoing rigorous testing with a rapid fielding plan initially targeted to hit combat units by the end of 2021, the Army's fielding was put on hold due to technical concerns.<sup>9</sup>

AR/MR is in the initial stages of adoption by the Army, and even with the current delay, we believe now is the ideal time to consider the potential obstacles prior to integration. For the AR/MR systems, scalability and meeting the stated goals as the "next generation 24/7 situational awareness tools and high resolution digital sensors to deliver a single platform that improves Soldier sensing, decision making, target acquisition, and target engagement," focus cannot be at the individual soldier level but must be expanded to commanders and units up to battalion and brigade.<sup>10</sup> We do not fight at the individual or squad level; the ability to support commanders and scalability to higher echelons is key to success. If functional, the information advantage generated by aggregated real-time combat information to build an operational picture enables multi-domain operations, shorter decision cycles, and rapid engagement with cross-domain assets. These are considerations that need to be contemplated prior to use in combat; ignoring these considerations will potentially increase risk during combat operations.

## Human, Technological, and Environmental Considerations

Human factors inputs to AR/MR have traditionally focused on the display of information to enhance user comprehension. In the developed systems to support dismounted soldiers, researchers have shown evidence for egocentric views, overlapping displays, and multimodal communication methods.<sup>11</sup> In the tactical setting, an individual soldier must carry out the duties as a rifleman and team member. One of our immediate concerns is how the visualization and information

flow distract from tactical awareness based on human senses and the interaction with the team. However, the difficult problem lies on two fronts: one is the appropriate technological support, and the other is switching between tasks to provide context-specific information.

Examining the technology, one of the biggest challenges is battlefield data verification. When directing troop movements on the battlefield, commanders need to be supported with data that is accurate, maintains integrity, and is current with the operational environment. Given the demands on AR/MR devices and even using current technology, there is a need to exchange a certain level of data back to a central compute-and-storage resource. However, as in the case of GPS location data, there is an underlying assumption that the data coming into an AR/MR device has not been manipulated and represents ground truth (e.g., it is not spoofed or jammed). Therefore, the approach to this needs to represent certainty or trust in the data and to understand how to tailor that data to each soldier's experience level.<sup>12</sup> Data manipulation and loss of integrity, or spurious data, will lead to subpar decision-making and, in the worst case, casualties. The soldiers trust the pixels with their lives, and if the technology is not reliable, it will no longer be used.

From a task perspective, soldiers must be able to switch between multiple tasks and roles without delay. For example, one minute a soldier could be firing at a distance, while the next moment directing supporting fires, seeking cover, hauling ammunition, or providing medical support to an injured teammate. While this is feasible, research shows that there needs to be appropriate information and context to support task switching within AR/MR.<sup>13</sup> Therefore, as technology develops, there needs to be an understanding of the primary tasks such that interfaces can appropriately support each. Support can be facilitated by obtaining soldier goals and breaking down task requirements accordingly.<sup>14</sup> In the event that an unknown event occurs, the interface needs to be cognizant and adjust to neither interfere with nor add to the soldier's cognitive burden.<sup>15</sup>

## Overdependence on Technology

Soldiers train as they fight, and while an AR/MR system has many practical uses, its usage must be balanced to ensure that basic combat skills do not atrophy. For example, Army leadership has long acknowledged



Soldiers from the Old Guard test the second iteration of the Integrated Visual Augmentation System capability set during an exercise at Fort Belvoir, Virginia, in the fall of 2019. (Photo by Courtney Bacon)

the importance of conducting analog land navigation with a map, compass, and protractor.<sup>16</sup> While an AR/MR system is potentially effective for pre-mission training and objective familiarization, care must be taken to ensure that soldiers can still accomplish assigned critical individual and collective tasks without it for those occasions where it is unavailable. For example, the best electronics are worthless without a reliable power source, and even the best safety glasses and facial shields heavily degrade combat effectiveness once they fog up. An increased reliance on a digitized display of the environment and mission can lead to a loss of operation without the support of AR/MR. Overreliance on visual situational presentation to perform duties is not new or unique to AR/MR technology. Navy aviators use the term HUD-Cripple to describe the idea that a pilot becomes so reliant on technology that the individual is incapable of performing his or her tasks without relying on the technology.<sup>17</sup>

There is evidence that junior leaders are already falling behind on basic combat skills, so a deliberate effort must be employed to ensure that any fielded AR/MR system does not result in an overreliance on the

given technology, thereby reducing combat lethality in its absence.<sup>18</sup> This will require more time for training in the field and garrison so soldiers can practice both AR/MR and nonaugmented iterations.

## Unit and Soldier Experience Level

In research design, one seeks to explain as much as one can with as little as possible and without losing rigor. The same challenge goes for AR/MR, where rigor could be the information's validity and applicability. The information presented in the AR/MR tactical systems needs to be accurate, relevant, and timely, without creating a distraction or interrupting the information flow in the tactical setting. Units and soldiers have different experience levels, so information has a variation in value down to the soldier level. The variation in experience level can be significant, from war-fighting abilities, operating AR/MR equipment, to optimizing resource usage.

From a tactical perspective, a unit that utilizes AR/MR systems for command and information flow will only operate at a high level if it is restricted to key leaders, typically squad leaders and above. Combat engagements are fought at the four-member fire team level.<sup>19</sup> Directing individual members to engage known, likely, and suspected targets is the team leader's job. Whether it is clearing a singular room or clearing an entire town, the only difference is the number of teams engaged, but their individual tasks remain relatively unchanged.

A squad is comprised of two teams and this provides the squad leader a slight degree of separation from the immediate fight. This separation enables the squad leader to focus on directing the individual teams and maintaining communication with platoon leadership to ensure that the squad remains nested in the platoon mission.<sup>20</sup> Any disruption as two soldiers lose connectivity to the AR/MR system would directly impact the dynamic and the efficiency of the squad, especially for fire team members. Those junior soldiers make up the bulk of combat forces—the increased data provided by an AR/MR system has the potential to overwhelm and confuse, resulting in sensory overload and reduced combat effectiveness. Even though AR/MR offers the potential to distribute information to the individual soldier level, the appropriate level for distributing information needs to be carefully considered. Filtering and retaining information at the squad leader level frees team leaders to focus on maneuvering and employing their soldiers without encumbrance by further distractions.

As these devices see more frequent use across echelons, there are potential research areas that can be explored. One option is to provide the appropriate levels of information to the person viewing that information. This will require understanding the critical

**Dr. Jan Kallberg** is a research scientist at the Army Cyber Institute at West Point and an assistant professor at the United States Military Academy. His professional certifications include ISACA Certified Information Security Manager and ISC2 CISSP. He earned a PhD and an MA from the University of Texas at Dallas and a JD/LLM from Stockholm University. Born Swedish, he served in the Swedish army as a platoon leader and company commander in light infantry and as a cavalry officer (Ranger).

information elements that a decision-maker needs to be able to have access to. In previous research, this is known as providing separate or specialized views for different categories of users.<sup>21</sup>

## Sensor Integrity

As previously mentioned, accepting wearable AR/MR devices for tactical information and communication depends on trust. From a soldier's perspective, he or she has to trust that his or her equipment functions as intended. Soldiers should not doubt the equipment's basic functions performance under combat conditions. For example, the Naval Department of Ordnance's failure to acknowledge the deficiency of the Mark 6 torpedo in the early years of World War II negatively affected submarine captains' willingness to engage targets.<sup>22</sup> If the sensor's data integrity is dubious, the lack of trust will force commanders to refrain from using AR/MR.

AR/MR devices and sensors are invariably constructed with general purpose computing hardware and will inherit the operating system and hardware's innate vulnerabilities.

Although these lessons can

**Maj. Victor Mitsuoka, U.S. Army**, is a logistician with fifteen years of experience, including but not limited to sustainment operations, Army pre-positioned stock, and Lean Six Sigma. Mitsuoka has deployed to Kuwait, Afghanistan, and Qatar and holds a master's degree in information security policy and management from Carnegie Mellon University. Mitsuoka was a developer on the Army Cyber Institute's Army Radio Frequency Visualization (ARFVIZ) project that visualized the radio spectrum so a commander can easily understand the threat wireless electronic devices represent to combat operations.

**Maj. Victor Beitelman, U.S. Army**, is a U.S. Army signal officer with twelve years of conventional and SOF Signal Corps experience. Beitelman has deployed to Iraq and Afghanistan and holds a master's degree in information technology management from Webster University. Beitelman also was a small business owner prior to joining the Army and currently holds an active CISSP certificate from ISC2.

be applied in the abstract to all AR/MR devices, the Army's IVAS is based on the HoloLens 2 and provides poignant, recent examples. Not only does the HoloLens 2 run on Windows 10 (and thereby inherits its vulnerabilities), but components tweaked for the HoloLens can also introduce new integrity issues. An early HoloLens patch fixed a vulnerability in which a remote device got the HoloLens to execute arbitrary code simply by sending malformed Wi-Fi packets, which is the HoloLens's most common form of communication with other networked devices.<sup>23</sup> While "[the] HoloLens 2 security architecture was designed and engineered from the ground up to be free from legacy security issues ... creating a minimized attack surface," security vulnerabilities are still (naturally) being discovered.<sup>24</sup>

A technologically advanced adversary will certainly devote research during peacetime to develop simple, inexpensive, one-time use, tossable devices that can—in close combat—create spurious sensor data. Such an adversary will also be inclined to invest the time and resources into gaining unauthorized access into AR/MR devices in order to manipulate the effectiveness of the device and to negatively influence the wearer's decision-making cycle.

## Electromagnetic Signatures

The last few years have seen a revival of spectrum and electronic warfare (EW), where all major military forces seek to degrade and disrupt utilization of the electromagnetic spectrum (EMS).<sup>25</sup> We consider the challenges facing AR/MR systems from both the radio frequency (RF) and infrared (IR) perspective. The AR/MR worn systems are dependent on access to networked communication using the EMS to carry data traffic, even to reach local resources.<sup>26</sup> While the transmission range to maintain high-quality Wi-Fi connectivity is relatively low (100–200 m), the detectable range is far greater. With increased contention over control of the EMS, electromagnetic signatures of the worn AR/MR systems can alert hostile forces that friendly forces are present in an area.<sup>27</sup> The constant streaming of data effectively makes each AR/MR worn system a uniquely identifiable beacon, even if the traffic itself cannot be deciphered.

Infrared emissions provide an adversary with another identifiable signature. The AR/MR-worn system's IR camera provides a tactical advantage as the

thermal imaging can visualize camouflaged hostile forces and detect still-warm equipment, such as machine guns that have recently fired, electronic equipment, engines, and generators. However, commercial-worn AR/MR rely on IR light to sense hand movements and other nonverbal instructions for the system. The IR light emission is detectable, especially in an environment with no or limited light, conflicting IR emissions.

In the growing contention over the EMS, fixed sensing equipment is no longer the only threat for detecting AR/MR emissions. For example, drones with the ability to conduct electromagnetic harvesting could detect the presence of worn AR/MR systems. The increasing presence of loitering munitions on the modern battlefield is another avenue for detection.<sup>28</sup>

The ability to detect the transmissions of worn AR/MR systems by either of these capabilities, combined with the challenge of detecting their presence especially during hours of limited visibility, demonstrates a real and growing threat vector. The need to share relevant and timely information must be balanced with the need to minimize the detectability of soldiers using AR/MR equipment.

## Extreme Weather, Energy Consumption, and Battery Life

The future operational environment for AR/MR includes extreme heat, cold, humidity, and other environmental conditions that can degrade electronic performance. The major powers (i.e., the United States, Russia, China, India, France, and the United Kingdom) envision future operational environments that range from the arid deserts of the Middle East and Africa to the cold weather-exposed high mountains of Southwest Asia and Europe and to the tropical jungles of the Indo-Pacific and South America. The varying environmental conditions will affect electronic equipment, increasing the likelihood of malfunctions and exacerbating the challenge to maintain sufficient power for system functionality. Dust, heat, humidity, and daily wear and tear can affect the sensors and the electronic equipment.

The battery life for the IVAS system, for which the base system is the civilian Microsoft HoloLens 2 headset, is currently eight hours.<sup>29</sup> A twelve-hour engagement would then require at least two sets of batteries or recharges. The risk is that the ongoing need to either



replace batteries or recharge them impacts a unit's tactical performance.

Adding to the climate condition complexity, operations are likely to occur in desolate areas that lack infrastructure such as a robust power grid to provide power to charge batteries and maintain electronic equipment. The absence of infrastructure also impacts the logistic chain, which in turn affects the access to supplies for repair or replacement of faulty equipment such as electronic components.

The tactical units are equipped with an advanced battery charger, but generators on the battlefield are cumbersome and require constant resources of their own (e.g., fuel, unless solar power is available). Additionally, a generator creates sound and heat signatures, which increase the likelihood that the unit will be detected by an adversary.

Solar panels are not always suitable; high north (i.e., Arctic or Siberian regions) winters do not have sufficient daylight for adequate energy supply by solar panels the majority of the year. The preceding factors, combined with current battery technology, which does not hold the same charge when it gets colder, means that battery capacity can be reduced to half the expected output, and adds to the challenge.<sup>30</sup>

Battery power can be a limiting power for extended usage of the equipment. Even if equipment is tested in cold weather under limited time, the future special operations operational environment in great power competition with longer missions and with less support increase the stress and wear on the equipment. Exposure to frigid conditions can also make plastic components brittle, leading to discomfort for the operator. These usability concerns require future studies into battery technologies and functionality under extreme environmental conditions.

## Network Reliance and Scalability

Seen from a division and brigade level, network connectivity becomes a single point of failure as the tactical unit's ability to fight using AR/MR is contingent upon

**Chief Warrant Officer 3 Jeremiah Pittman, U.S. Army**, is the 4th Infantry Division deputy cyber and electromagnetic activities (CEMA) chief and former research scientist focusing on electronic warfare at the Army Cyber Institute at West Point. He previously served in the 75th Ranger Regiment.

the operational unit's ability to provide tactical connectivity at the point of contact. Potential near-peer adversaries focus on engaging EW capabilities at the operational level to suppress and degrade overarching networks. While this is concerning with regards to combat operations (e.g., indirect fires), it is even more concerning when attacking AR/MR networks, which are crippled without network connectivity. The AR/virtual reality (VR) systems rely on high-quality data with maintained data integrity through limited delivery channels using the unregulated 802.11 wireless frequency ranges.

From a friendly fire standpoint, the number of AR/VR systems deployed within a platoon area of operations would quickly overwhelm the limited available wireless bandwidth. Recent network studies have shown that the so called "last mile"—the Wi-Fi network where wireless devices connect to an access point—is still the single point of failure for delivering performant networked services.<sup>31</sup> The voluminous bandwidth required by dozens of AR/VR systems in a small area could quickly cause "friendly fire" incidents in the radio frequency RF spectrum, where the density of AR/VR systems creates denial of service for all local systems. This problem is compounded exponentially in an urban environment where AR/MR are most useful; rogue wireless transmissions

**Dr. Michael W. Boyce** is a CEMA research psychologist assigned to the Army Cyber Institute at West Point and Engineering Psychology Program at the U. S. Military Academy. He also is the human factors lead for the Cyberspace Warfare for Training Program, Army Futures Command, Combat Capabilities Development Command Soldier Center, Simulation and Training Technology Center (Orlando). Boyce graduated from the University of Central Florida with a degree in human factors in 2014.

**Lt. Col. Todd W. Arnold, U.S. Army**, is an Army cyber officer serving as a senior research scientist and team lead for the Army Cyber Institute at West Point's Cyber Operations-Research and Engineering team and is an assistant professor in the U.S. Military Academy's EECS Department. He received a BS from U.S. Military Academy in 2001 and an MS from Penn State University in 2008, both in computer science, and earned his PhD in electrical engineering at Columbia University in 2020.

(e.g., civilian home networks) will directly interfere with AR/VR systems' communications.

Operational orders have alternative routes as texts, voice, and data and could also choose different networks such as satellite communication (SATCOM), high-frequency radio (HF), and very-high frequency radio (VHF). There is a higher likelihood that operational orders, in an EW-saturated environment, reach the intended receiver compared to an undisrupted functional AR/VR system. From an adversary's perspective, which should be a part of our risk assessment, the AR/MR supporting networks are mission-critical and identifiable for targeting.

## Conclusion

For tactical AR/MR systems to be a viable enhancement for soldiers and increase their fighting ability, addressing the areas presented in this article with a well-defined prioritization and additional research and testing is

required. Each soldier has limited ability, like any human, to process information rapidly and sustain that ability over time so care must be taken to avoid information overload. The technical stability and reliability of AR/MR systems are pivotal to their successful implementation; any disruption or partial functionality could drastically reduce the effectiveness of the combat unit.

A fighting force is trained and drilled to coordinate movement, fires, and actions, which creates an all-or-nothing deployment of the AR/MR system. If the system does not work for a fraction of the unit, the whole unit has to fight without the AR/MR system to avoid misunderstandings and losing the advantage of unit cohesion and coordination. In future potential conflicts with near-peer adversaries, rapid adoption and integration of technology will be essential, but doing so requires a methodical approach to avoid creating new vulnerabilities for adversaries to exploit. ■

---

## Notes

1. "Integrated Visual Augmentation System PM IVAS," Army.mil, accessed 21 January 2022, <https://www.peosoldier.army.mil/Program-Offices/Project-Manager-Integrated-Visual-Augmentation-System/>.
2. "IVAS Is Prime Example of Moving Fast," Association of the United States Army (AUSA), accessed 21 January 2022, <https://www.ausa.org/news/ivas-prime-example-moving-fast>.
3. Chris Westbrook and Kathryn Bailey, "New Faces and New Tech Provide the Right Mix of Know-How and Speed," Army.mil, accessed 21 January 2022, <https://www.army.mil/article/236576/>.
4. Oliver Blanchard, "Why Microsoft's \$21 Billion IVAS XR Contract with the U.S. Army Is a Much Bigger Deal than Meets the Eye," Futurum Research, 12 April 2021, accessed 21 January 2022, <https://futurumresearch.com/research-note/s/microsofts-21-billion-ivas-xr-contract-with-the-u-s-army/>; Kellen Browning, "Microsoft Will Make Augmented Reality Headsets for the Army in a \$21.9 Billion Deal," *New York Times* (website), 21 March 2021, accessed 21 January 2022, <https://www.nytimes.com/2021/03/31/business/microsoft-army-ar.html>.
5. Jeremiah Rozman, "The Synthetic Training Environment," Spotlight 20-6 (Washington, DC: AUSA, December 2020), accessed 21 January 2022, <https://www.ausa.org/sites/default/files/publications/SL-20-6-The-Synthetic-Training-Environment.pdf>.
6. Michael N. Geuss et al., "Visualizing Dynamic and Uncertain Battlefield Information: Lessons from Cognitive Science," *Proceedings of SPIE*, vol. 11426 (27 April 2020), accessed 21 January 2022, <https://spie.org/Publications/Proceedings/Paper/10.1117/12.2558509?S-SO=1>; Michael Morozov, "Augmented Reality in Military: A.R. Can Enhance Warfare and Training," Jasoren, accessed 21 January 2022, <https://jasoren.com/augmented-reality-military/>.
7. Courtney Bacon, "IVAS Goggle Amplifies Mounted Capabilities," Army.mil, 18 February 2021, accessed 21 January 2022, <https://www.army.mil/article/243505/>.

8. Demond Cureton, "U.S. Army to Use IVAS Holo-Lens Kit in September," *XR Today*, 9 June 2021, accessed 21 January 2022, <https://www.xrtoday.com/mixed-reality/us-army-to-use-ivas-hololens-kit-in-september/>.
9. Joseph Lacdan, "Acting Secretary: Army to Build on Modernization Momentum," Army.mil, 17 March 2021, accessed 24 January 2022, <https://www.army.mil/article/244322/>; "Integrated Visual Augmentation System PM IVAS"; Ashley Roque, "Fielding Pressure Led to Expedited IVAS Production Contract, Technology Problems Discovered Later," *Janes.com*, 29 October 2021, accessed 24 January 2022, <https://www.janes.com/defence-news/news-detail/fielding-pressure-led-to-expedited-ivas-production-contract-technology-problems-discovered-later>.
10. "Integrated Visual Augmentation System PM IVAS."
11. M. Meyers et al., in "Modeling and Simulations World," ser. *MODSIM WORLD '21* (2020); David C. Roberts et al., "Soldier-Worn Augmented Reality System for Tactical Icon Visualization," *Proceedings of SPIE* 8383, Head- and Helmet-Mounted Displays XVII; and Display Technologies and Applications for Defense, Security, and Avionics VI, 838305 (21 May 2012), <https://doi.org/10.1117/12.921290>; Chris Argenta et al., "Graphical User Interface Concepts for Tactical Augmented Reality," *Proceedings of SPIE* 7688, Head- and Helmet-Mounted Displays XV: Design and Applications, 768801 (5 May 2010), <https://doi.org/10.1117/12.849462>.
12. Geuss et al., "Visualizing Dynamic and Uncertain Battlefield Information."
13. Xiong You et al., "Survey on Urban Warfare Augmented Reality," *ISPRS International Journal of Geo-Information* 7, no. 2 (2018), <https://doi.org/10.3390/ijgi7020046>.
14. Ibid.
15. Geuss et al., "Visualizing Dynamic and Uncertain Battlefield Information."

16. Michelle Tan, "Back to Basics: Army Dials Up Traditional Soldiering Once Again," *Army Times* (website), 5 July 2016, accessed 24 January 2022, <https://www.armytimes.com/news/your-army/2016/07/05/back-to-basics-army-dials-up-traditional-soldiering-once-again/>; Shanika L. Futrell, "Land Navigation: Training Hard for Mission Success," *Army.mil*, 8 February 2013, accessed 24 January 2022, <https://www.army.mil/article/96160/>.

17. Brett Lindberg and Jan Kallberg, "Augmented Reality: Seeing the Benefits Is Believing," C4ISRNET, 17 July 2020, accessed 24 January 2022, <https://www.c4isrnet.com/opinion/2020/07/17/augmented-reality-seeing-the-benefits-is-believing/>; Maria Rosala, "Task Analysis: Support Users in Achieving Their Goals," Nielsen Norman Group, 20 September 2020, accessed 24 January 2022, <https://www.nngroup.com/articles/task-analysis/>.

18. Matthew Cox, "Most Army Squads Falling Short on Infantry Skills, Reports Find," *Military.com*, 22 April 2019, accessed 24 January 2022, <https://www.military.com/daily-news/2019/04/22/most-army-squads-falling-short-infantry-skills-reports-find.html>.

19. Army Techniques Publication (ATP) 3-21.8, *Infantry Platoon and Squad* (Washington, DC: U.S. Government Publishing Office [GPO], April 2016), accessed 24 January 2022, [https://armypubs.army.mil/epubs/DR\\_pubs/DR\\_a/pdf/web/ARN13842\\_ATP%203-21x8%20FINAL%20WEB%20INCL%20C1.pdf](https://armypubs.army.mil/epubs/DR_pubs/DR_a/pdf/web/ARN13842_ATP%203-21x8%20FINAL%20WEB%20INCL%20C1.pdf); David Lipscomb, "Job Description and Military Resume for a Team Leader," *Chron*, accessed 24 January 2022, <https://work.chron.com/job-description-military-resume-team-leader-23399.html>.

20. ATP 3-21.8, *Infantry Platoon and Squad*.

21. Long Chen et al., "A Command and Control System for Air Defense Forces with Augmented Reality and Multimodal Interaction," *Journal of Physics: Conference Series* 1627, no. 1 (August 2020), accessed 24 January 2022, <https://iopscience.iop.org/article/10.1088/1742-6596/1627/1/012002>; Nicholas R. Hedley et al., "Explorations in the Use of Augmented Reality for Geographic Visualization," *Presence: Teleoperators and Virtual Environments* 11, no. 2 (2002): 119–33, <https://doi.org/10.1162/1054746021470577>.

22. Ian W. Toll, *The Conquering Tide: War in the Pacific Islands, 1942–1944* (New York: W. W. Norton, 2015).

23. Nick Heath, "Windows 10 Security: HoloLens Gets First Patch Tuesday Fix from Microsoft," *TechRepublic*, 12 July 2017, accessed 24 January 2022, <https://www.techrepublic.com/article/windows-10-security-hololens-gets-first-patch-tuesday-fix-from-microsoft/>.

24. "Security Overview and Architecture," Microsoft, 30 December 2020, accessed 24 January 2022, <https://docs.microsoft.com/en-us/hololens/security-architecture>; "April 13, 2021—KB5001342 (OS Build 17763.1879)," Microsoft, <https://support.microsoft.com/en-us/topic/april-13-2021-kb5001342-os-build-17763-1879-52e9180d-0cd3-4ab9-8a35-514c07ea9e08>.

25. Algirdas Revaitis, "Contemporary Warfare Discourse in Russia's Military Thought," *Lithuanian Annual Strategic Review* 16, no. 1 (2018): 269–301, <https://doi.org/10.2478/lasr-2018-0010>; Jan E. Kallberg, Stephen S. Hamilton, and Matthew G. Sherburne, "Electronic Warfare in the Suwalki Gap: Facing the Russian 'Accompli Attack,'" *Joint Force Quarterly* 97 (2nd Quarter, 2020): 30–38, accessed 24 January 2022, [https://ndupress.ndu.edu/Portals/68/Documents/jfq/jfq-97/jfq-97\\_30-38\\_Kallberg-Hamilton-Sherburne.pdf?ver=2020-03-31-160230-160](https://ndupress.ndu.edu/Portals/68/Documents/jfq/jfq-97/jfq-97_30-38_Kallberg-Hamilton-Sherburne.pdf?ver=2020-03-31-160230-160).

26. "DOT&E FY 2020 Annual Report," The Office of the Director, Operational Test and Evaluation, accessed 24 January 2022, <https://www.dote.osd.mil/annualreport/>.

27. Chris Cruden, "Manhunting the Manhunters: Digital Signature Management in the Age of Great Power Competition," *Modern War Institute at West Point*, 3 May 2021, accessed 24 January 2022, <https://mwi.usma.edu/manhunting-the-manhunters-digital-signature-management-in-the-age-of-great-power-competition/>.

28. David Hambling, "Russia Plans 'Flying Minefield' to Counter Drone Attacks," *Forbes* (website), 20 April 2021, accessed 24 January 2022, <https://www.forbes.com/sites/davidhambling/2021/04/20/russia-plans-flying-minefield-to-counter-drone-attacks/?sh=2ad9c96d5754>.

29. Rozman, "The Synthetic Training Environment"; Todd South, "Army Moves Ahead on 'Mixed Reality' Goggle with Microsoft in \$21.8 Billion Contract," *Army Times* (website), 31 March 2021, accessed 24 January 2022, <https://www.armytimes.com/news/your-army/2021/03/31/army-moves-ahead-on-mixed-reality-goggle-with-microsoft-in-218-billion-contract/>.

30. Technical Manual 4-33.31, *Cold Weather Maintenance Operations* (Washington, DC: U.S. GPO, February 2017), accessed 24 January 2022, [https://armypubs.army.mil/epubs/DR\\_pubs/DR\\_a/pdf/web/TM%204-33x31%20FINAL%20WEB.pdf](https://armypubs.army.mil/epubs/DR_pubs/DR_a/pdf/web/TM%204-33x31%20FINAL%20WEB.pdf).

31. The Khang Dang, "Cloudy with a Chance of Short RTTs: Analyzing Cloud Connectivity in the Internet," *IMC '21: Proceedings of the 21st ACM Internet Measurement Conference* (November 2021): 62–79, <https://doi.org/10.1145/3487552.3487854>.

## Interested in getting a personal subscription to *Military Review*?

Requests for personal subscriptions should be sent to the U.S. Government Publishing Office. For information on cost and instructions for subscribing online, visit <https://bookstore.gpo.gov/products/sku/708-099-00000-7?ctid=1387>.



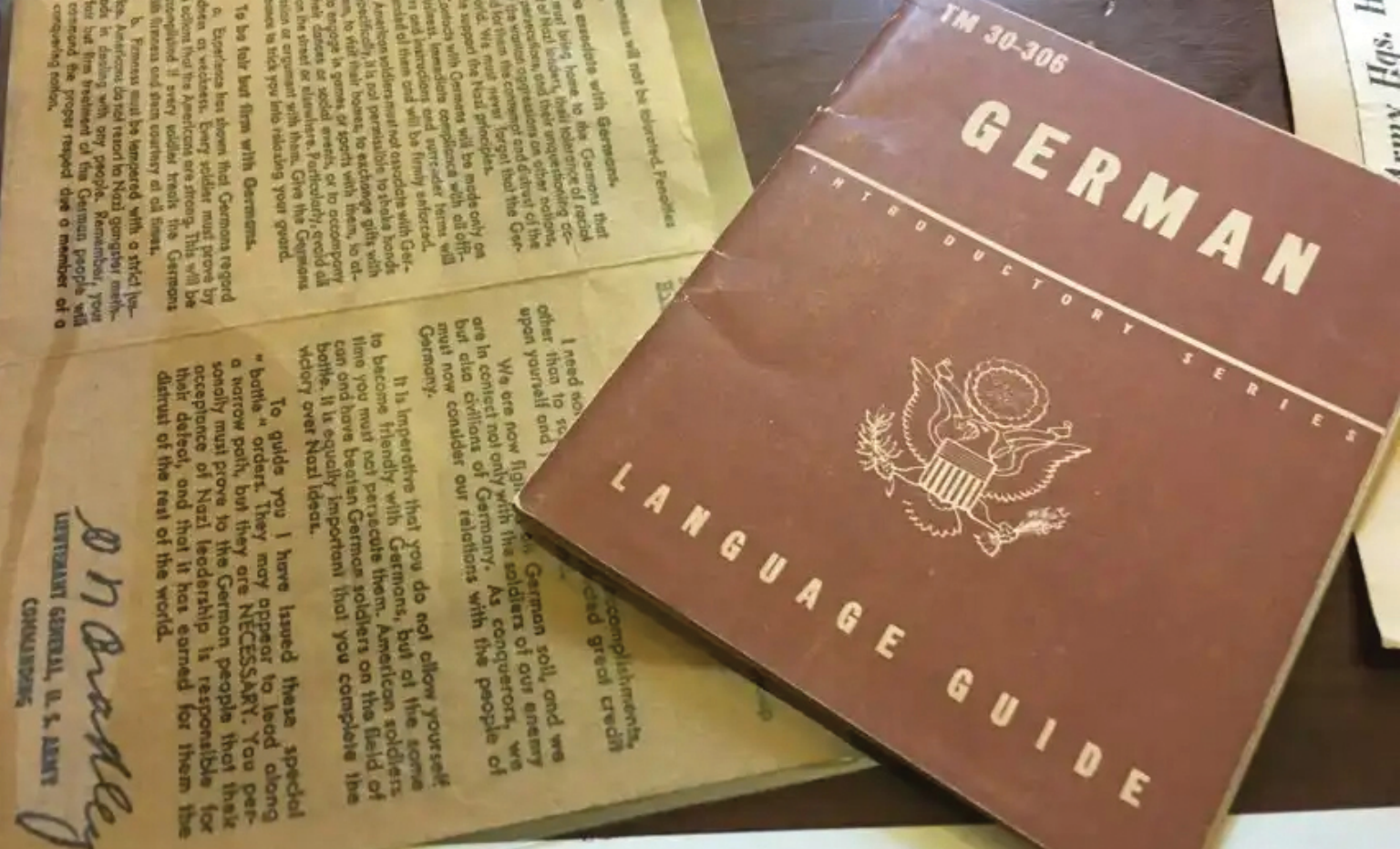

Special orders for World War II historian Forrest C. Pogue, signed by Lt. Gen. Omar Bradley, and a German language field manual. Prior to World War II, Forrest C. Pogue was a popular history teacher at Murray State University, Kentucky. Drafted at the outbreak of World War II, he was assigned to a newly reorganized historical unit and tasked with writing the history of the Second United States Army in the conflict. He began his assigned research project by interviewing soldiers wounded during D-Day in June 1944 and remained with frontline soldiers for eleven months, collecting oral interviews on a mobile recording device. Finishing the assigned history project in 1945, he was discharged from the Army and resumed his academic career, specializing in military history. (Photo courtesy of the Pogue Library)

# History While It's Hot

## How a Group of U.S. Army Combat Historians Helped Preserve the GI's Perspective in Europe during World War II

Carson Teuscher

*“How did the experiences of these interviews, and of being a ground-level historian, affect your understanding of the war?” she asked.*

*“I think I never really felt, as a combat historian, that I was making all that much contribution to the history of the war,” [Pogue] recollected. “I could see so little of it. All I was adding was a postscript, or something. But as a historian I was learning a great deal that might go into anything I wrote in the future.”*

—Forrest C. Pogue and Holly C. Schulman, “Forrest C. Pogue and the Birth of Public History in the Army”

By 8 a.m. on 7 June 1944, the mist and smoke cleared sufficiently for Forrest C. Pogue to see Omaha Beach from the deck of his American troopship. He was one day late; the previous morning, Allied soldiers stormed Normandy’s beaches under withering enemy fire in one of the war’s defining moments. American soldiers aboard Pogue’s vessel jostled to see the action unfolding ashore. Pogue, awake since 4 a.m., remembered filling his vomit bag twice as the ship listed in the waves. Listening to the captain’s morning farewell, Pogue watched disembarking soldiers climb down nets into awaiting landing craft. He later recalled their cool, calm demeanor. Exhibiting “no special qualms, no bravado,” everyone knew their baptism by fire would come as soon as they entered the hills overlooking the beachhead.<sup>1</sup>

Rather than assault the beaches with amphibious troops, Pogue and several others remained onboard as spectators, witnessing the chaos beyond the beachhead. As a U.S. Army combat historian, Pogue’s war officially started that evening when medical personnel brought

the dead and wounded soldiers back to the ship. Using a small notepad to record responses to his questions, Pogue tried to get at the true story of D-Day.<sup>2</sup>

He started by asking two wounded soldiers what happened onshore. One man grumbled about catching “hell from the snipers”; another cursed his luck for landing on the wrong beach. He had been shot through the hand climbing a tree to get a better view of the battlefield.<sup>3</sup> Pogue scribbled a few lines in his notebook and continued interviewing men as they came aboard.

Pogue went ashore the next day. From 8 June 1944 until V-E Day, he roamed the front lines, shared foxholes

with soldiers, interviewed men and officers, and recorded war from their perspective. Pogue’s work—and the work of many combat historians like him scattered throughout every major theater of operations—marked a radical development in American military affairs. Never had the U.S. Army employed combat historians to record firsthand experiences of frontline combat infantry units.

Of this process, Pogue recalled, “I don’t think it ever occurred to any of the people that I was working with ... [that] we were making use of a new kind of history.”<sup>4</sup> With its corpus of primary source material, after the war the military commissioned a groundbreaking series of “narrative operational accounts,” “theater and campaign histories,” “administrative histories,”

and a “general popular history” of the Army’s involvement in the global struggle.<sup>5</sup> Kent Roberts Greenfield, chief historian of the Army after the war, labeled the Army’s official historical venture “the most ambitious enterprise in the writing of contemporary history ... undertaken in our time,” a true “pioneering effort to write narrative official military history.”<sup>6</sup>



Forrest C. Pogue (Photo courtesy of the Pogue Library)

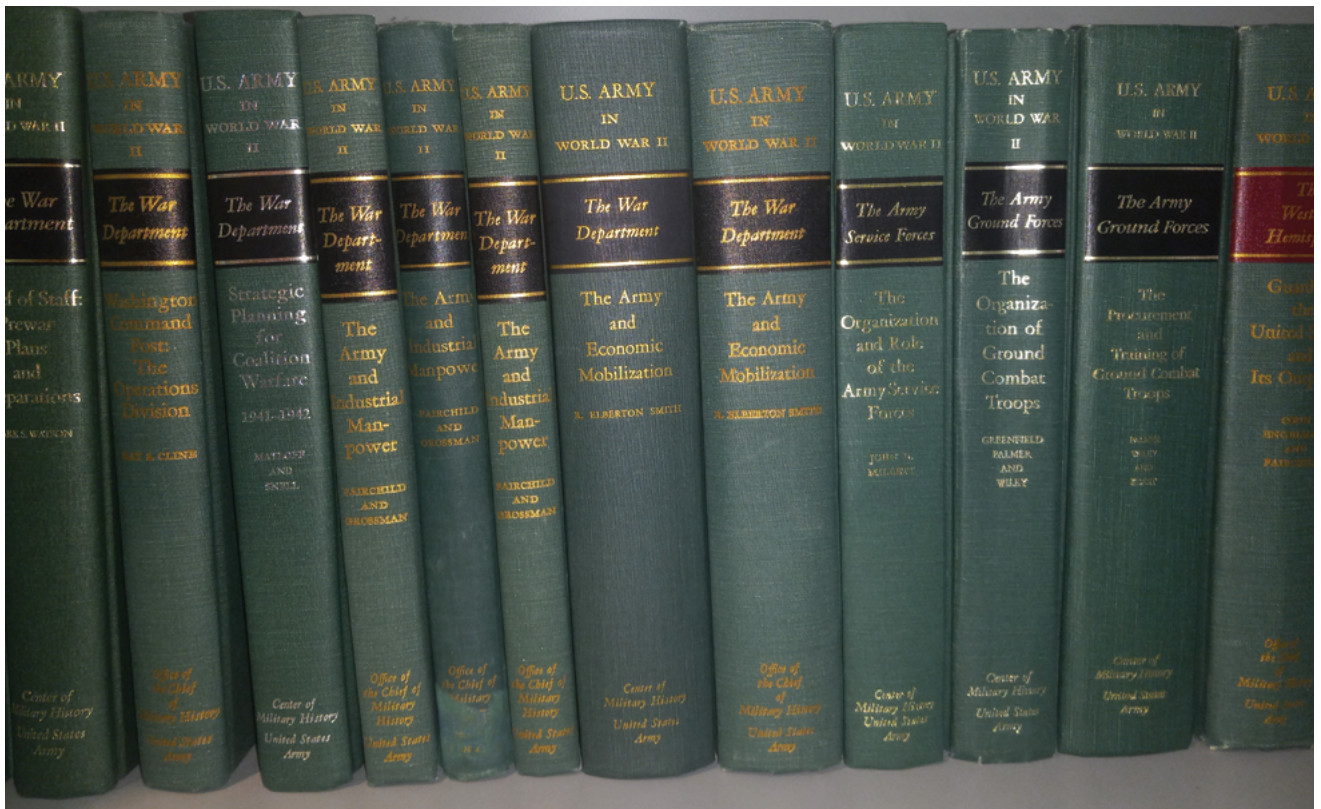

A small selection of books from the seventy-eight-volume *U.S. Army in World War II*, better known as the “Green Books.” (Photo courtesy of *Military Review*)

The Army’s postwar enterprise to produce its own history certainly marked a radical departure from older forms of official Army history. Since the Civil War, the majority of Army historians had primarily engaged in preserving, collating, and publishing compendiums of official military documents. Military officers who strayed into the realm of narrative historical writing were often criticized for perpetuating institutional biases, glorifying violence, and ignoring the human cost of war.<sup>7</sup>

Between 1890 and 1914, civilian academics in the newly professionalized field of military history increasingly felt the glut of “narrowly specialized military histories” overshadowed the lived experiences of soldiers on the battlefield.<sup>8</sup> Clamoring for unrestricted access to the Army’s military documents, as early as 1912 the

American Historical Association and the U.S. War Department tried developing a “progressive coordinated history program” to “kindle a vital spirit of professionalism among its officers and elevate the study of war to an

intellectual level consistent with other learned professions in American society.”<sup>9</sup> However, underfunded, understaffed, and lacking popular appeal, this attempt at civil-military historical cooperation soon collapsed.

Still, though the endeavor faltered, it did not fail. During World War II, the Army responded emphatically to President Franklin D. Roosevelt’s 1942 executive injunction for all civilian and military departments to preserve “an accurate and objective account” of the war for future generations.<sup>10</sup> By the end of the war, the Army’s combat historians—many of them civilian academics before the conflict—had roamed battlefields in every theater, collecting 17,120 tons of records, a capacious trove that would theoretically fill 188 miles of filing cabinets stacked end to end.<sup>11</sup> After the war, many of these combat historians embarked on the decades-long production of the *U.S. Army in World War II* series, a seventy-eight-volume narrative account of America’s involvement in World War II known better as the “Green Books.”

**Carson Teuscher** specializes in military history at Ohio State University. Teuscher received his BA in history from Brigham Young University in 2016 and an MSt in U.S. history from the University of Oxford in 2017.



Lt. Col. S. L. A. Marshall, a chief U.S. Army combat historian, interviews a group of infantrymen in Normandy in August 1944. (Photo from *SLAM: The Influence of S. L. A. Marshall on the United States Army*)

This article briefly traces the recruitment, training, and fieldwork conducted by historians like Pogue who, plying their trade in the European theater of operations during World War II, helped lay the groundwork for “the largest undertaking in narrative historical work the American nation had ever known.”<sup>12</sup> Col. William Ganoë, head of the Historical Section, G-3, European theater of operations, reiterated this point during the war: “It is difficult for us to realise that this Headquarters is now making vital history every day,” he wrote. “With conscious endeavour not to over-emphasize the importance of the Section charged with recording that history, it is nevertheless clear that the conception of researching and drafting the story of the ETO contemporaneously with passing events is probably one of the most signal advances in the writing of American history.”<sup>13</sup>

Collectively, U.S. Army historians like Pogue redefined official history by emphasizing historical objectivity while including ground-level testimonies to preserve the human side of war. Their corpus of wartime combat interviews and the novel methodological techniques they employed to curate and analyze them underpinned the Army’s decades-long postwar effort to preserve its history, largely overcoming the inaccessibility and institutional biases plaguing prewar official military histories.

## Stumbling into the Job: The Recruitment of U.S. Army Combat Historians

Roosevelt’s March 1942 initiative kick-started an unprecedented expansion of military history programs within the U.S. Army. By June 1942, several War Department branches had already called up individuals to serve as historical officers within the organization’s various agencies. The commanding generals of the Army ground forces, Army air forces, and services of supply followed suit, calling historical officers to serve at each of their branch headquarters. During this early period, few knew what form of history the federal government wanted written, or what sort of activities these officers would undertake. Despite the order to preserve an objective narrative account of each agency’s wartime development, the lack of precedent, unclear staff assignments, and dearth of qualified staff nearly felled the operation before it began.<sup>14</sup>

In this climate, it was a miracle certain individuals ended up in the U.S. Army Historical Section at all. In



spring 1943, a young private named Kenneth Hechler, training to become a tank commander at Fort Knox, Kentucky, was called out of the ranks by Brig. Gen. Stephen G. Henry. The commanding officer led Hechler to a room and began discussing a mandatory autobiography of “interests and experiences” he had written and submitted prior to his arrival on the base. Having been given a demerit for being caught one night poring over his assignment with a flashlight under his covers, the young private worried further trouble was afoot. Recalling the conversation after the war, he recalled how his superior officer surprised him, calling his “a most remarkable autobiography. I don’t think you ought to be a tank commander,” he said. “I think we ought to assign you to something a little bit more useful in the Army.”<sup>15</sup>

Hechler saluted him gratefully. Before enlisting in the Army as a private, he had received his PhD from Columbia University, working closely with renowned historians like Allan Nevins whose own interwar pioneering work has been assessed as the genesis of the modern academic oral history movement. As a graduate student before the war, Hechler acquired a substantial amount of experience. He taught courses, worked in the federal government’s Bureau of Budget, and even worked as a research assistant to Roosevelt’s speechwriter, Judge Sam Rosenman. Clearly, Hechler was

Lt. Col. S. L. A. Marshall compiling interview notes in Normandy in 1944. (Photo from *SLAM: The Influence of S. L. A. Marshall on the United States Army*)

more than qualified for work in the Army’s inchoate Historical Section.<sup>16</sup>

Like Hechler, a host of other individuals were found scattered throughout the Army with suitable backgrounds. Pogue—Gen. George C. Marshall’s future award-winning biographer who received the Bronze Star and French Croix de Guerre for frontline interviewing—was plucked from relative obscurity as an infantry private after a student he had taught before the war at Murray State working in an Army office recognized and recommended him for service.<sup>17</sup> S. L. A. Marshall, a World War I veteran and “old-line newspaperman” for the *Detroit News*, was initially recruited when the prose and style of his 1942 report on the Tokyo Raid impressed members of the Army Historical Branch. Marshall later pioneered frontline interviewing techniques employed by historical officers in every theater.<sup>18</sup>

Some men simply recruited themselves. Maj. Jesse S. Douglas, a military historian serving on the records management branch of the Adjutant General’s Office, requested his own transfer when an August



1943 directive broadening the scope of the Historical Section arrived at his desk. Like Douglas, Israel Wice, later described as a “pearl of great price” in the Historical Section, requested his own transfer when he saw the same directive.<sup>19</sup> An “old-boy network” functioning behind the scenes often used previous academic connections to pick out peacetime scholars from the mobilized ranks. Others, like Roland Ruppenthal, who applied for the Historical Section, heard nothing for several months, only to be admitted almost a year later. He never found out if he was selected from his own existing connections or churned through the cogs of military bureaucracy.<sup>20</sup>

These men, along with most who ended up in the Historical Section, “brought academic professional standards of scholarship with them.”<sup>21</sup> Occupying positions of leadership were men who had taught history and literature at Harvard, Williams College, Johns Hopkins University, West Point, and Columbia—to name a few.<sup>22</sup> Working for them were men ranging from Ivy League PhDs to African American English professor and army officer Ulysses Grant Lee Jr. who later wrote the definitive history of African American wartime military contributions.<sup>23</sup>

Their academic backgrounds reinforced a commitment to rigorous objectivity, a professional standard the

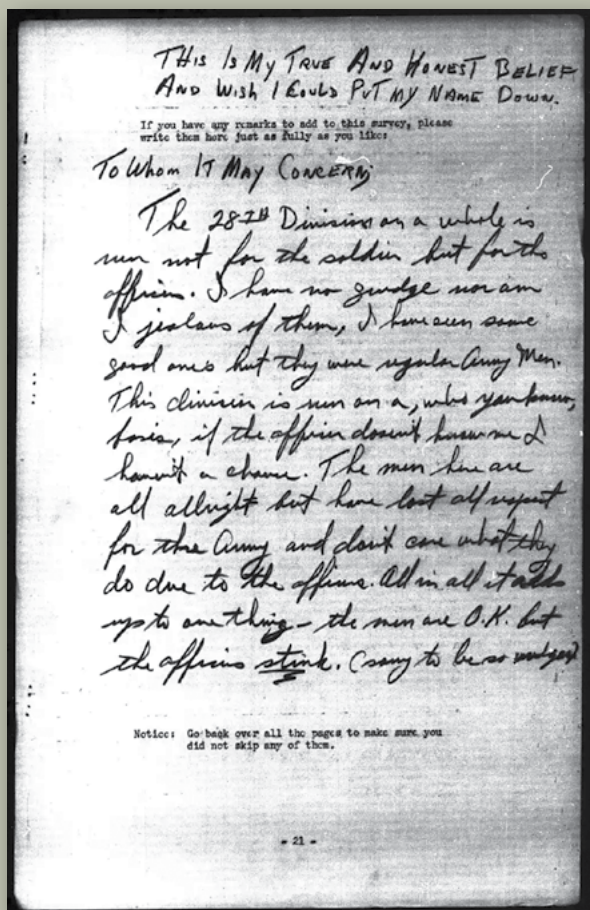

In one example of survey comment, an anonymous U.S. Army soldier opined a “true and honest belief” that “the 28th Division on a whole is run not for the soldier but for the officers.” The writer concludes, “All in all it adds up to one thing: the men are O.K. but the officers stink.”

## Farsighted Army: World War II Social and Historical Research

Early in World War II, the U.S. War Department created the Army Research Branch, a social and behavioral sciences unit that surveyed and interviewed approximately half a million soldiers over the course of the war. Participating service members were promised anonymity.

Tens of thousands of those soldiers filled out the lengthy surveys and provided handwritten commentary.

While the quantitative data was digitized and made available through the U.S. National Archives and Records Administration and Cornell University’s Roper Center for Public Opinion Research, until 2018, the comments were available only to those who could view them on microfilm rolls on-site at the National Archives building in College Park, Maryland. Working closely with Virginia Technical University, The National Endowment for the Humanities provided grants to create searchable digital archives of the soldiers’ personal insights into their military service. More detail is available at <https://liberalarts.vt.edu/news/articles/2018/04/insights-of-american-soldiers-during-world-war-ii-to-be-made-ava.html>.



fledgling Historical Section embraced. As Pogue later commented, “The field commanders stood by us when we took the point of view that we did not write history for the purpose of selling the Army as an all-perfect organization.”<sup>24</sup> They were determined to keep official history honest. The recruitment process provided a critical injection of “energy, fresh approaches ... innovation, and determination” into a historical branch suffering in the beginning from vague objectives and bureaucratic infighting.<sup>25</sup> Finding their way through various channels to their respective positions, their recruitment began, in official historian Stetson Conn’s words, the “honest cooperation between two professional groups, the professional officers of the Army and the professional historians of the nation, each recognizing and respecting the needs and interests of the Army.”<sup>26</sup>

### Training for the Field

Even in the months before the advent of the Historical Section, many combat historians gleaned a great deal of knowledge about the Army’s organization

An image and uniform of Ken Hechler, former World War II historian, West Virginia secretary of state, and U.S. congressman, at a memorial service 10 December 2016 at the West Virginia Culture Center in Charleston, West Virginia. (Photo courtesy of the *Charleston Gazette-Mail*)

from basic training and boot camp. During his first year of training as a private, Pogue frequently went to the camp library to digest books about the mechanics of military operations, helping him better understand those he later interviewed.<sup>27</sup> Likewise, despite his Ivy League pedigree, Hechler enlisted as a private to, in his words, “learn a little bit about the army from the bottom up.”<sup>28</sup> As their training became more formalized, their background knowledge of military structures, processes, and responsibilities lent insight into the quotidian existence of their historical subjects.

Building on Marshall’s pioneering use of the combat interview in the Pacific, several of the newly formed teams of combat historians initially met in Washington

to receive a more academically rigorous training under Col. Hugh M. Cole.<sup>29</sup> There, combat historians spent several weeks receiving an indoctrination in military history and were briefed on the nature of after action reports and official records.<sup>30</sup> Using documents sourced from the Papuan campaign in the Pacific, one group reconstructed a narrative history of the battle for New Guinea. Teaching them to identify the types of documents required to compose a balanced history, the practice exposed them to another reality: Pogue soon observed that while “modern war was better documented than conflicts of the past, the task of piecing together the truth was just as difficult.”<sup>31</sup> It was “locating and remedying those voids in the historical evidence,” according to Edward Drea, that “became an integral part of the expanding demands of their work.”<sup>32</sup>

Combat historians were soon flown to their theaters of operation to undergo additional training. In-field training was less rigorous. Stationed in England on the

eve of D-Day, Pogue and his fellow historians spent hours each day studying Army tactics and organization. They were, however, also free to roam and explore. On any given walk, Pogue recalled, “one could meet people from every sort of background.”<sup>33</sup> Their informal walks gave them the opportunity to hear personal wartime experiences from a variety of individuals by starting open, honest conversations—a practice that soon became a hallmark of their wartime service.

While abroad, Pogue and his fellow historians in the European theater of operations thirsted for “access to ‘the big picture.’”<sup>34</sup> Only after the implementation of Allied deception plans, the conferral of security clearances, and proximity to the cross-channel invasion were the Army’s field historians granted the ability to work with classified documents. Soon, their newfound appreciation for the magnitude of Allied D-Day plans ushered them into the final phase of their preparation for fieldwork: the feverish digestion of operational planning materials.

# Military Review

## WE RECOMMEND

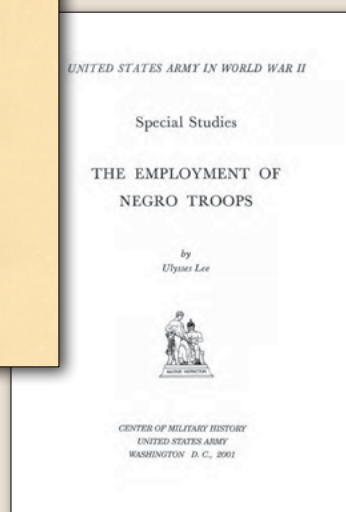
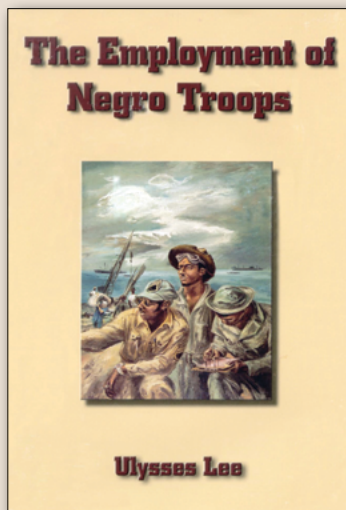

Serving as an editorial analyst in the field during World War II, African American scholar Capt. Ulysses Lee, PhD, later wrote *The Employment of Negro Troops* while serving as a member of the Office of the Chief of Military History from 1946 to 1952. Drawing upon both exhaustive research as well as his personal interactions with African American soldiers during the war, this volume provides both a candid history as well as biting social analysis and commentary pertaining to the social factors necessary for minority soldiers to serve optimally in the U.S. Armed Forces. It has long been regarded as the definitive U.S. Army standard work on the subject. To view this publication, visit [https://history.army.mil/html/books/011/11-4/CMH\\_Pub\\_11-4-1.pdf](https://history.army.mil/html/books/011/11-4/CMH_Pub_11-4-1.pdf).

## WE RECOMMEND

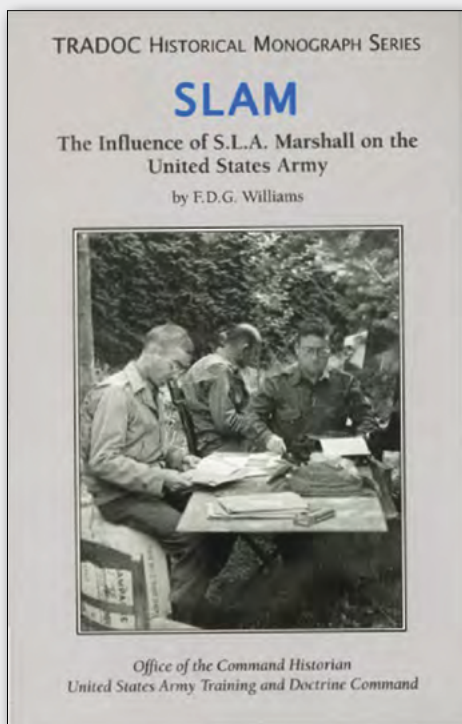

The TRADOC historical monograph *SLAM—The Influence of S.L.A. Marshall on the United States Army* provides a brief biographical overview of the individual generally regarded as the originator of modern-day Army combat research methodology. This volume touches upon the many facets of the career of Marshall and his contributions to each as a World War I soldier, a newspaper reporter, a war correspondent, a combat historian, and ultimately, a war critic. Marshall's pioneering methodology for collecting interviews directly from combat soldiers who had just participated in battles is generally regarded among current military historians as the foundation for one of the most important dimensions of today's U.S. Army standard historical collection operating procedures.

To view this monograph, visit [https://history.army.mil/html/books/070/70-64/cmhPub\\_70-64.pdf](https://history.army.mil/html/books/070/70-64/cmhPub_70-64.pdf).

“Much time has been spent in reading through plans and annexes for the coming operation. Time is terribly short,” one historian noted. “The entire team should have been with the Army headquarters months ago.”<sup>35</sup>

Prior to D-Day, Pogue's section of combat historians were assigned equipment, slept outside among the soldiers, and for the first time began experiencing “the real feel of war.”<sup>36</sup> Their formal and informal preparation cultivated the strategic awareness and interpersonal skills needed to interview others, contextualize battlefield developments, operate within a command hierarchy, adapt to the chaos of operational developments, and synthesize fragmented battlefield data into manageable, streamlined accounts. Operating under strict time constraints, the preparation process was overwhelming, but paled in comparison to the task ahead. “We asked each other,” Pogue recalled, “if we can't even read the [D-Day] plan in a month, how can we expect in length to get a story of what happened?”<sup>37</sup>

### Preserving History “While It's Hot”

In the fall of 1944, combat historians in the European theater lived in the field—exposed to the elements alongside the men whose stories they sought to preserve. German snipers on the Allied perimeter for months had been targeting officers whose bars on their helmets would “glisten in the sun.” Hechler, following the lead of those around him, covered his own bars with cosmoline, a “sticky, greasy” waterproof material. One day, a jeep bedecked with American flags careened into the camp where he was stationed. Hechler recalled being summoned by the jeep's primary occupant—Gen. George S. Patton—who roared, “God damn it, are you proud of your rank?” Replying in the affirmative, Patton rebuffed Hechler: “Well, then dig that goddamn stuff off your helmet or I'll rip that insignia off of your uniform right here and now!”<sup>38</sup> For combat historians as any other soldier, anything could happen in the field.

Fieldwork required adaptability; each campaign was an ever-unfolding learning experience. Sometimes combat historians slept in the open through rainstorms and random artillery bursts. Those coming ashore after D-Day dug their own foxholes. Frequently within hearing distance of the front, occasionally, as the battle lines shifted, they even took enemy fire. “I had the happy opportunity of being sniped at once,” Maj. Jerry O'Sullivan, a member of Pogue's team in France, recorded two weeks



Enlisted and civilian personnel of the Historical Section at work. (Photo courtesy of F. D. G. Williams, *SLAM: The Influence of S. L. A. Marshall on the United States Army*)

after D-Day. “It is pretty noisy and rugged [near the front], but I must confess I’d have liked nothing better than to have stayed on.”<sup>39</sup> Lt. John S. Howe labeled front-line operations “a welter of confusion and mystery.”<sup>40</sup> They rarely had special amenities: It was D+29, or 5 July 1944, when Pogue finally noted his first change of clothes into his diary; he had not changed trousers since leaving London for his unit on 28 April, nor cleaned them since leaving Memphis in March.<sup>41</sup>

Like their combat environment, interactions with peers often proved unpredictable. Some interviews unfolded spontaneously over the course of a few minutes. Consulting maps, written records, and multiple eyewitnesses, other sessions lasted several hours. While most interviews were cordial, reactions from certain uncooperative commanders ranged from belligerently blowing off historians they viewed as interlopers to gently encouraging them to act “contrary to their original instructions.”<sup>42</sup> Aware their reputations were on the line, commanders and soldiers were often reluctant to open up about their combat experience, forcing historians to reconcile misaligned memories and mediate arguments between irritated divisional chiefs of staff and other personnel over their interpretation of specific events. Drea wrote how historians’ personalities proved crucial in guiding their historical efforts as “resourcefulness, imagination, and talent” were often required to convince

superior officers they were worth the time.<sup>43</sup> Where these skills failed, cigarettes and flattery went a long way.

Operating within a friction-filled battlespace, combat historians spent their days moving and interviewing, compiling notes to supplement after action reports, and later, drafts of their campaign narratives. They carried portable typewriters with them, writing on desks in tents, trailers, or the great outdoors. With one pair of historians assigned to each of the Army’s combat corps, the duos acquired strategic plans, maps, and overlays to contextualize the unit engagements unfolding before them—“down to the division, regiment, battalion, company, and platoon levels.”<sup>44</sup> According to Hechler, historians added individual testimonies to their narrative analyses to make the after action reports more “meaningful,” all in an attempt “to catch these things while they were still hot in the minds of the people.”<sup>45</sup>

Writing after the war, Chief Historian of the Army Kent Greenfield argued that “oral history and interviewing techniques” tended to “yield diminishing returns as time passes.”<sup>46</sup> Because memory becomes more selective and fragile over time, “obtaining on the ground

and at the time those happenings and statements which have a chance of being lost or distorted later” ultimately became one of the foremost contributions of the Army’s combat historians.<sup>47</sup> Observations litter the Historical Section’s wartime records citing the importance of conducting their work in a timely manner. As one example, as Maj. Jerry O’Sullivan walked the Normandy beachhead on D+11, he recognized “a crying need for a draftsman” to sketch the unfolding scenes “because this beach changes from day to day, hour to hour.” “My idea in getting this thing on paper,” he told his superior, “is that if it isn’t done soon, the whole thing will be lost.”<sup>48</sup> Such observations reflect the degree to which combat historians hoped to preserve firsthand memories of events while they were yet unfolding.

## Conclusion

Today, as the last members of the war generation pass away, personal access to firsthand memories of World War II are in increasingly short supply. Thanks to the enduring corpus of published work created by the historians of the Army’s Historical Section in the conflict’s aftermath, members of the public today can freely learn about every aspect of the United States’ civil-military involvement in the war.

The legacy of the Army’s combat historians, however, reverberates beyond the “Green Books” and their fingerprint on future official histories. Such work possessed obvious utility as a guide to future leaders, “so that, when we are again involved in war, this country may be prepared to repeat that which proved to be successful, and avoid that which has caused us trouble.”<sup>49</sup> In their professional lives,

individuals like Pogue and Hechler, among others, pursued illustrious academic and public service careers after the war; to this day, the Organization of American Historians continues to confer an annual “Forrest C. Pogue” award due to his wartime use of oral history in combat and subsequent efforts to champion its utility within the academy. Modeling contemporary historical endeavors on their original work, the Army’s Military History Detachment today still employs combat historians in battlefield operations—many of them civilian academics—and has in every major conflict since World War II.

Arguably, however, their biggest contribution remains housed in archives around the world. Merging academic standards of objectivity with their mandate to produce digestible narrative histories, thousands of firsthand interviews conducted during their time overseas form the backbone of a priceless repository of wartime memories preserved on microfilm designed to survive millennia. By preserving the human face of World War II, these combat historians facilitated the creation of official histories that never lost sight of the men and women who lived them, inspiring future generations to do the same. ■

*Military Review expresses its great appreciation to the following individuals who conducted research and facilitated acquiring rare photo imagery in the development of this article: LaDonna Hamontree, Pogue Library, Murray State University, Kentucky; Kenny Kemp, visual editor/chief photographer, Charleston Gazette-Mail, West Virginia; Dan Barbuto and Cynthia Leighton, Ike Skelton Combined Arms Research Library, Fort Leavenworth, Kansas; and Gregory Statler, U.S. Army Heritage and Education Center, Carlisle, Pennsylvania.*

---

## Notes

**Epigraph.** Forrest C. Pogue and Holly C. Schulman, “Forrest C. Pogue and the Birth of Public History in the Army,” *The Public Historian* 15, no. 1 (Winter 1993): 35, accessed 23 September 2021, <https://www.jstor.org/stable/3378031>.

1. Forrest C. Pogue, *Pogue’s War: Diaries of a WWII Combat Historian* (Lexington: University Press of Kentucky, 2001), 54–55.

2. *Ibid.*, 56.

3. *Ibid.*, 58.

4. Pogue and Schulman, “Forrest C. Pogue and the Birth of Public History in the Army,” 31.

5. Edward J. Drea, “Change Becomes Continuity: The Start of the U.S. Army Green Book Series,” in *The Last Word? Essays on Official History in the United States and British Commonwealth*, ed.

Jeffrey Grey (Westport, CT: Praeger, 2003), 83–104; “Military History of the Second World War,” Memorandum No. W345-21-43, August 3, 1943, Historical Directives (National Archives Microfilm Publication 63-9, Roll 23), U.S. Army, U.S. Forces, European Theater, Historical Division: Records, 1941–1946, Record Group [RG] 498, National Archives and Records Administration II [NARA II], College Park, Maryland, 1.

6. Kent Roberts Greenfield, *The Historian and the Army* (New York: Kennikat Press, 1953), 6.

7. Carol Reardon, *Soldiers and Scholars: The U.S. Army and the Uses of Military History, 1865-1920* (Lawrence, KS: University Press of Kansas, 1990), 165. Col. William Ganoe, Chief of the Historical Section, G-3, European theater of operations during World War II, observed how the Army’s new endeavor differed from past official

military histories: "War data in America ... has been particularly scant because we had to dig what was left from the termite years later. It too often was without life, truth or its main parts. What good does it do the student at Leavenworth or the War College to know that Hooker suddenly went into a defensive position at Chancellorsville or that the First Division crunched the tail of Dickman's Corps. The illuminating, revealing and educationally helpful thing is why the commanders did what they did. That is the missing mortar. With bricks alone (after fragments), we can't build worthwhile experience tables." See Untitled, n.d., Administrative History Collection, Historical Section, ETOUSA, Folder 161, (National Archives Microfilm Publication 63-9, Roll 22), U.S. Army, U.S. Forces, European Theater, Historical Division: Records, 1941-1946, RG 498, NARA II.

8. John Whiteclay Chambers II, *Oxford Companion to American Military History* (Oxford: Oxford University Press, 1999), 224, 316.

9. As an example, the promised documentary compendiums on America's involvement in World War I would not be published until 1948. See Bell I. Wiley, *Historical Program of the U.S. Army 1939 to Present [1945]* (Washington, DC: Office of the Chief of Military History, U.S. Army, 1945), 1-3.

10. *Ibid.*, 8-9.

11. Greenfield, *The Historian and the Army*, 6.

12. Stetson Conn, "Launching 'The United States Army in World War II,'" *Army History*, no. 31 (1994): 37, accessed 13 October 2021, <https://www.jstor.org/stable/26304192>.

13. "Notes on Importance and Possible Extension of this Section," May 27, 1943, Administrative History Collection, Historical Section, ETOUSA, Folder 161, (National Archives Microfilm Publication 63-9, Roll 22), U.S. Army, U.S. Forces, European Theater, Historical Division: Records, 1941-1946, RG 498, NARA II.

14. Drea, "Change Becomes Continuity," 85; Jamie W. Moore, "History, the Historian, and the Corps of Engineers," *The Public Historian* 3, no. 1 (Winter 1981): 64, accessed 23 September 2021, <https://www.jstor.org/stable/3377162>; Wiley, *Historical Program of the U.S. Army 1939 to Present [1945]*, 9-14.

15. Ken Hechler, interview by Niel M. Johnson, "Oral History Interview with Ken Hechler," Harry S. Truman Library and Museum, 29 November 1985, 57-60, accessed 23 September 2021, <https://www.trumanlibrary.org/oralhist/hechler.htm>.

16. *Ibid.*

17. Pogue and Schulman, "Forrest C. Pogue and the Birth of Public History in the Army," 30.

18. Chambers, *Oxford Companion to American Military History*, 420; F. D. G. Williams, *SLAM: The Influence of S.L.A. Marshall on the United States Army*, ed. Susan Canedy (Washington, DC: U.S. Army Training and Doctrine Command, 1999), v, accessed 23 September 2021, [https://history.army.mil/html/books/070/70-64/cmhPub\\_70-64.pdf](https://history.army.mil/html/books/070/70-64/cmhPub_70-64.pdf).

19. Wiley, *Historical Program of the U.S. Army 1939 to Present [1945]*, 40, 43.

20. Drea, "Change Becomes Continuity," 87.

21. Rebecca Conard, *Benjamin Shambaugh and the Intellectual Foundations of Public History* (Iowa City: University of Iowa Press, 2001), 156.

22. Stetson Conn, *Historical Work in the United States Army 1862-1954* (Washington, DC: U.S. Army Center of Military History), 190; "Military History of the Second World War," 2.

23. See Ulysses Lee, *United States Army in World War II Special Studies: The Employment of Negro Troops* (Washington, DC: Office of the Chief of Military History, U.S. Army, 1966).

24. Conard, *Benjamin Shambaugh*, 156. For more on the professionalization of history in the United States and the discipline's quest for objectivity, see Peter Novick, *That Noble Dream: The 'Objectivity Question' and the American Historical Profession* (Cambridge: Cambridge University Press, 1988).

25. Drea, "Change Becomes Continuity," 86.

26. Conn, "Launching 'The United States Army in World War II,'" 41.

27. Pogue, *Pogue's War*, 5.

28. Johnson, "Oral History Interview with Ken Hechler," 57-60.

29. G. Kurt Piehler, "Veterans Tell Their Stories and Why Historians and Others Listened," in *The United States and the Second World War: New Perspectives on Diplomacy, War, and the Home Front*, ed. G. Kurt Piehler and Sidney Pash (New York: Fordham University Press, 2010), 222.

30. Pogue, *Pogue's War*, 2.

31. *Ibid.*

32. Drea, "Change Becomes Continuity," 88.

33. Pogue, *Pogue's War*, 8.

34. *Ibid.*

35. "Report of Activities, 7-15 May 1944," Memorandum to Colonel William A. Ganoe, May 25, 1944, Historical Section, ETO (1943-1945), (National Archives Microfilm Publication 63-9, Roll 23), U.S. Army, U.S. Forces, European Theater, Historical Division: Records, 1941-1946, RG 498, NARA II, 1-3; Pogue, *Pogue's War*, 27.

36. Pogue, *Pogue's War*, 23.

37. *Ibid.*, 30-31.

38. Johnson, "Oral History Interview with Ken Hechler," 70-71.

39. Sgt. Major Jerry O'Sullivan to Colonel William A. Ganoe, Chief of the Historical Section, European theater of operations, June 17, 1944, Historical Team Reports (National Archives Microfilm Publication 63-9, Roll 23), U.S. Army, U.S. Forces, European Theater, Historical Division: Records, 1941-1946, RG 498, NARA II, 1-2; H. Lew Wallace, "Forrest C. Pogue: A Biographical Sketch," *The Filson Club Quarterly* 60, no. 3 (July, 1986): 383-84.

40. John S. Howe, "Report of Activities, 19-26 June 1944," June 26, 1944, Historical Section HQ, First U.S. Army, (National Archives Microfilm Publication 63-9, Roll 23), RG 498, NARA II.

41. Pogue, *Pogue's War*, 140.

42. *Ibid.*, 9; "Diary—Team #1—HQ, ETOUSA," May 15, 1944, Historical Section HQ, First U.S. Army, (National Archives Microfilm Publication 63-9, Roll 23), RG 498, NARA II, 13.

43. Drea, "Change Becomes Continuity," 88-89. O'Sullivan noted how Pogue found "Colonels and Generals eager to talk to him," adding from his own experience "that if those men find you know what you want and are sincere about what you are doing they will go out of their way to cooperate." O'Sullivan to Ganoe, 1.

44. Johnson, "Oral History Interview with Ken Hechler," 64-65.

45. *Ibid.*

46. Greenfield, *The Historian and the Army*, 10.

47. "Record of Oral Material," Memorandum to Brigadier General Julius C. Holmes, Deputy Assistant Chief of Staff, G-5, SHAEF, n.d., (National Archives Microfilm Publication 63-9, Roll 23), RG 498, NARA II.

48. O'Sullivan to Ganoe, 2.

49. "History of the Services of Supply, European Theater of Operations, United States Army," June 23, 1943, Historical Directives, (National Archives Microfilm Publication 63-9, Roll 23), RG 498, NARA II, 1.

# The Other Face of Battle

## America's Forgotten Wars and the Experience of Combat

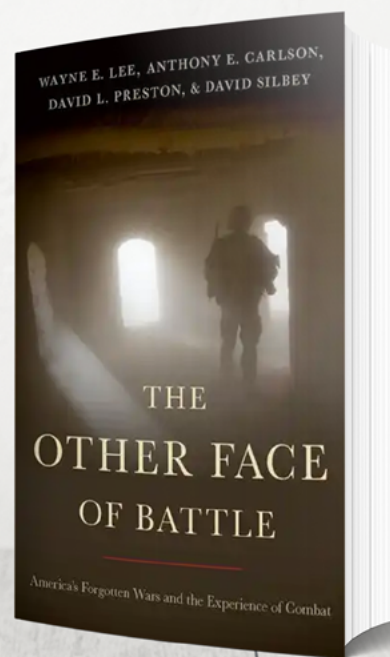

Wayne E. Lee, David L. Preston, Anthony E. Carlson, and  
David Silbey, Oxford University Press, New York, 2021, 272 pages

Donald P. Wright, PhD

**O**n rare occasions, a book arrives at exactly the right moment. As the U.S.-led Coalition departed Afghanistan in the summer of 2021, Oxford University Press published *The Other Face of Battle: America's Forgotten Wars and the Experience of Combat*. Neither the publisher nor the four historians who authored this volume could have foreseen the disastrous end to the Coalition presence. And few—participants or observers—would have imagined the scenes at Hamid Karzai International Airport as the last Coalition units and a relatively small number of their Afghan partners left Afghanistan. *The Other Face of Battle* does not offer an explicit explanation of how the Coalition's campaign went awry, but it does provide some urgently needed insights into how two decades of military operations in Afghanistan seemed to have achieved so little and ended so chaotically.

As the title suggests, this book follows in the footsteps of *The Face of Battle*, the work by the eminent military historian John Keegan originally published in 1976 and

still in print. Keegan's book has become a classic and continues to fascinate readers forty-five years after its publication. In *The Face of Battle*, Keegan offers systematic analyses of three battles in which English/British armies fought: Agincourt (1415), Waterloo (1815), and the Somme (1916). In each of these accounts, the author examines in detail how the different arms (infantry, cavalry, artillery) fared when matched against the arms of European peer adversaries with very similar military cultures. He also describes aspects of battle such as morale, fatigue, the taking of prisoners, care for the wounded, and the role of disorder on the battlefield that previous generations of military historians tended to overlook in their attempts to create orderly and exciting combat narratives. These were the details that would provide a more complete picture of combat, or as Keegan put it, "a glimpse of the face of battle."

While inspired by Keegan's book, the authors of *The Other Face of Battle*—Wayne E. Lee, Anthony E. Carlson, David L. Preston, and David Silbey—have



broader ambitions. To be sure, they follow Keegan's work by devoting chapters to three battles from the American military experience, all of which include sections similar to those found in *The Face of Battle*. Each begins with descriptions of the larger campaigns of which these battles were part. Moving onto the battles themselves, the chapters capture and hold the attention of the reader as they vividly recount combat

engagements from largely forgotten conflicts. The authors chose to open the book with the Battle of the Monongahela (1755), an early action in the French and Indian War that took place at the point where the Ohio and Monongahela Rivers join. Today, the site is in downtown Pittsburgh but at the time was a small trading outpost in the wilds of the upper Ohio Valley, an area contested by both the French and the British.

“As this book points out, intercultural combat has dominated U.S. military history, meaning that American soldiers often came into conflict with enemies they did not expect to fight and whose culture was alien to them.”

actions while carefully assessing terrain, morale, care of casualties, and how U.S. arms and technologies fared against those of their adversaries.

Where the authors of *The Other Face of Battle* diverge from Keegan's work is in their selection of battles. As noted earlier, Keegan's choice of Agincourt, Waterloo, and the Somme featured adversaries that were from different nations but the same broad European culture in which norms and methods of warfare were generally shared. Because of these similarities, the battles in Keegan's book are characterized by *symmetric* combat, in today's terminology. *The Other Face of Battle* instead examines combat between two adversaries that do not share the same military culture and as a result approach combat with different norms, methods, and goals. The authors identify these types of battles as intercultural and consider them *asymmetric*. They further characterize intercultural conflict as “a clash of mindsets as much as weapons.” As this book points out, intercultural combat has dominated U.S. military history, meaning that American soldiers often came into conflict with enemies they did not expect to fight and whose culture was alien to them. In many cases, their lack of preparation for this type of combat led to defeat at the tactical level and had detrimental effects at the operational and strategic levels of war as well.

Given this focus, it should not be surprising that the battles recounted in this work are little known

The choice of this battle makes one of the authors' critical points: even before the founding of an independent United States, intercultural combat was part of the American military experience. The battle itself pitted two British infantry regiments, reinforced by several companies from Virginia and other colonies, against a slightly smaller French force that included Canadian militiamen and approximately six hundred warriors from the Ojibwa, Wyandot, Potawatomi, and other Indian nations. These two forces met near Fort Duquesne, the strongpoint constructed by the French to consolidate control over the Ohio Valley.

To expel the French from this area, the British force had conducted an exhausting three-month march from the Virginia coast across the Appalachians and deep into the American wilderness, a movement for which few of the British Regulars were prepared. Less important than their physical state, however, were the shared assumptions about the upcoming action. The British commander, Maj. Gen. Edward Braddock, had expected to lay siege to Fort Duquesne and ultimately force the French to surrender. Instead, as Braddock's forces crossed the Monongahela to approach the fort, his advanced party entered a heavily wooded forest where the French and their Native allies waited in ambush.

As this chapter shows, it was the asymmetry between the British and Indian cultures of warfare in the battle that followed that proved decisive. In the first phase

of the action, French troops attacked the British force using European-style tactics, troops in close formation, and firing in unison. Braddock's infantry regiments had trained to meet precisely this type of attack and did so successfully, killing the French commander and forcing French forces to flee. The second phase of the battle was entirely different. In a section titled "Native Light Infantry versus British Heavy Infantry," the authors describe in harrowing detail how the irregular tactics of the Indian warriors first unnerved and then broke apart the disciplined ranks of the redcoat infantry. Small groups of native warriors used stealth to surround Braddock's column, and in the dim forest filled with smoke from the battle, let out traditional war cries as they began firing from behind trees into British lines or attacked in close quarters with war clubs and tomahawks. Unprepared for combat against an unseen enemy that prized hand-to-hand combat, the redcoat ranks largely dissolved and fled back to the Monongahela in a panic, hoping to cross the river to safety.

Many did not make it to the other bank. By late afternoon on the day of battle, most of the officers in Braddock's command had been killed or wounded. Overall, 66 percent of the British force became casualties while the killed and wounded among the French

**Don Wright** holds a PhD in European history from Tulane University. He has published on both the Imperial Russian Army and the U.S. Army in the Global War on Terrorism. Most recently, he co-edited *Enduring Success*, a volume of historical case studies on consolidating gains in large-scale combat operations. His chapter in that volume documents the U.S.-led Coalition's failure to consolidate gains in the early months of the campaign in Iraq in 2003. He currently serves as the deputy director of Army University Press.

and their Indian allies numbered well under one hundred. These statistics underscore the degree to which cultural asymmetry can shape a battle and affect its outcome. Importantly, in a discussion on discipline and panic, the authors note that a few of the colonial companies with Braddock at the Monongahela adapted better under fire than the redcoat regulars. Some of these Americans had fought the French and Indians during the previous year and were quick to disperse among the trees

and emulate other native light infantry tactics. Still, Braddock's force had suffered a terrible defeat, a debacle so great that it challenged assumptions among British commanders about the superiority of their military culture. This led to the expansion of ranger companies and other light infantry formations, innovations specifically designed to reduce the asymmetric advantages enjoyed by their foes at the Monongahela.

For the next 150 years, with short interruptions caused by symmetric wars against the British, Mexicans, and secessionist forces of the Confederacy, U.S. soldiers found themselves mired in a continuum of asymmetric conflict with the Indian nations of North America. By the 1890s, with Native communities either pacified or destroyed, these conflicts ended. Almost immediately, however, the U.S. Army found itself unexpectedly in a war in Asia with a wholly unknown enemy on terrain that was equally alien. Once again, the unanticipated enemy proved difficult to defeat.

That war began in 1898 with the United States initiating hostilities against Spain, expecting the main theater of conflict to be the Caribbean. That the war spread to the Spanish colony of the Philippines should not have been a complete surprise given Spanish possessions in Asia and U.S. ambitions in the Pacific region. Still, for the U.S. military, the campaign for the Philippines was entirely improvised, its initial political objectives in Asia remaining unclear for months after hostilities began. The military objectives, on the other hand, were relatively straightforward: take control of Manila Harbor and then seize Manila itself. The U.S. Navy's Asiatic Squadron defeated the small Spanish fleet and took the harbor in May 1898. The first elements of the U.S. Army's Eighth Corps, an amalgam of regular army regiments and state volunteer units, arrived in June and laid siege to the city. Joining the Eighth Corps were the soldiers of the newly proclaimed Philippine Republican Army, a mix of small Filipino forces that for several years had waged an insurgency against the Spanish. Neither the American nor the Filipino soldiers were experienced in conventional warfare. Despite this, the Spanish commander, understanding that reinforcements were unlikely, surrendered the city in August 1898 after brief resistance.

The Battle of Manila that is the focus of this chapter would not begin until six months later, after it became clear to leaders of the Philippine Army that the United

States did not intend to grant independence to the Philippine archipelago. The authors provide a very detailed account of this often-overlooked engagement, emphasizing the point that the battle was symmetric in the size, weaponry, and inexperience of the two forces. The fact that the U.S. Army mounted a surprise attack and won the battle decisively in less than forty-eight hours hinged on the shock of the action against static Philippine defensive positions, poor Philippine leadership at decisive moments in the engagement, and basic shortcomings such as the lack of ammunition and basic marksmanship skills within the Philippine Army.

The authors view the American victory at Manila through the lens of intercultural battle, arguing that the offensive zeal displayed by the inexperienced U.S. soldiers originated partly in their general assumptions about Filipinos. It is dismaying—if not surprising—to read that within the U.S. Eighth Corps, a force that was almost entirely white, there were a significant number of soldiers that equated Filipinos with Native Americans and African Americans, peoples they deemed as racially inferior. After the Battle of Manila, the Philippine Army gradually transformed itself into an insurgent force that denied much of the archipelago to the United States for almost two years, during which American soldiers gradually adapted to the new conflict. Filipino success demonstrated that the U.S. advantages in conventional warfare did not directly translate to success in unconventional warfare and belied the false assumptions of racial superiority on and off the battlefield.



Soldiers from 1st Battalion, 12th Infantry Regiment, 4th Infantry Division, rush down the side of a mountain to board a UH-60 Black Hawk helicopter after conducting a deliberate operation in Kandahar Province, Afghanistan, 23 August 2009. The 82nd Combat Aviation Brigade facilitated the deliberate operation by inserting and extracting the infantry soldiers into harsh terrain to assist in the disruption of insurgent communication. (Photo by Staff Sgt. Aubree Rundle, U.S. Army)

For the authors of *The Other Face of Battle*, the Philippine-American War was a milestone for the U.S. military but also revealing to non-Western powers



considering doing battle with the U.S. and European powers. For the U.S. Army, the critical lesson was to prepare for and seek conventional battle, shunning unconventional conflict in the process. Non-Western powers tacitly chose to accept the opposite lesson in the century that followed: avoid symmetrical battle with U.S. forces at all costs while choosing methods that produced asymmetric advantages that lead to military victory in the long term. For the better part of the twentieth century, the United States avoided large-scale asymmetric conflicts, and the U.S. Army held fast to its identity as a force that fights and wins conventional wars. Vietnam, a war that had both conventional and unconventional aspects, remains the major exception and the failure in that conflict remains a troubled chapter in U.S. military history. Instead, the U.S. Army has since 1945 tended to view its contribution in the Second World War as emblematic of its institutional role and place in national life.

The third battle chosen by the authors examines the American experience with intercultural conflict in the twenty-first century. That fight occurred in 2010 at the village of Makuan in southern Afghanistan, close to the city of Kandahar. Part of Dragon Strike, a joint U.S.-Afghan operation designed to clear the Taliban from

U.S. forces conduct a patrol of a green zone in the Kandahar province of Afghanistan on 21 November 2009. (Photo by Spc. Christopher Hubert, 55th Signal Company)

districts around Kandahar, the battle at Makuan pitted Bravo Company, 2nd Battalion, 502nd Infantry, and its Afghan National Army partners, against Taliban insurgents defending the village. Makuan sheltered a Taliban IED factory and served as a staging area for insurgent attacks on Coalition forces. While a relatively small settlement, the village was located deep inside the “Green Zone,” a thick maze of agricultural fields, irrigation canals, and walled compounds. When attacked directly, the Taliban in this region rarely chose to stand and fight. Instead, they sniped at Coalition forces and then retreated, luring their adversary more deeply into the complex terrain that was studded with IEDs, their weapon of choice. Some American soldiers considered the Taliban cowards for their style of fighting, and most grew very frustrated with this asymmetric form of combat in which their advantages in technology and firepower eroded almost to irrelevancy.

The Taliban defined victory differently than Coalition forces. Surviving a tactical engagement to

fight another day was more important than holding ground. Their predecessors, the mujahideen, had fought the Soviets in the 1980s on this same terrain, and although that struggle had taken ten years, they had prevailed using what was essentially the same approach. In fact, the Soviets—and their Afghan allies—had never gained sustained control over the rural districts surrounding Kandahar. Between 2001 and 2010, the U.S.-led Coalition did introduce counterinsurgency techniques to its campaign but still experienced frustration as it tried to suppress the Taliban insurgency near Kandahar and in other regions of Afghanistan as well. Despite this, the U.S. Army leaders who designed and approved the 2010 operation near Kandahar believed they could use a conventional offensive operation to land a decisive blow against the insurgents, convincing them to abandon their resistance to the Coalition and its project in Afghanistan.

The attack on Makuan began well enough. Reinforced with an Afghan National Army company, augmented with engineer units, and backed up by dedicated artillery and close air support, Bravo Company entered the Green Zone. They moved methodically toward the village, using explosives to clear IEDs while enduring attacks from insurgents who fired and then vanished. The large Coalition force entered Makuan with only minor opposition. What they found was a village filled with IEDs, all of which had to be identified and disarmed. That slow process took two more days and led to multiple casualties from explosive devices cleverly hidden inside buildings and along pathways. After clearing Makuan, Bravo Company withdrew and called in rocket strikes which destroyed the village. Makuan in the short term would no longer be a Taliban safe haven. But the cost of this accomplishment had been significant. The U.S.-Afghan force had lost two U.S. soldiers and several additional Afghan soldiers killed in action with dozens more wounded. Not surprisingly, the authors of *The Other Face of Battle* judge the operation as having an “ambiguous outcome, one in which both sides could claim victory.”

As this chapter smartly points out, the Afghan National Army units partnered with U.S. forces represented a third “side” in this battle. For U.S. soldiers in Makuan, the intercultural dissonance they experienced in fact extended to their relationship with these

Afghan allies. As they cleared Makuan, a succession of IED detonations in the village caused multiple Afghan Army casualties and led some of the Afghan soldiers to quit the battle after blaming U.S. troops for their casualties and, in two instances, entering an armed standoff with their American counterparts. Not only did the U.S. soldiers suffer from a critical misunderstanding of the insurgent enemy, but they were also handicapped by unaddressed cultural differences that separated them from the Afghans fighting alongside them. And these differences could be found at levels far above Bravo Company, where even senior U.S. military officers and diplomats, many of whom had spent multiple years in Afghanistan, made incorrect assumptions about the motivations and goals of their Afghan allies. This dissonance surely contributed to the Taliban’s shockingly quick seizure of power in the summer of 2021, perhaps decisively.

In its conclusion, *The Other Face of Battle* contends that the U.S. Army has historically chosen to overlook its experience with low-intensity conflicts to prepare for high-intensity conventional wars that are less likely but pose a greater threat to vital national interests. This point is not entirely new; for at least the last twenty years, historians teaching in professional military education institutions have made similar arguments. This book, however, makes a critical contribution by sharply clarifying our understanding of what this choice means. Over the last two centuries, the United States repeatedly committed its Army to low-intensity conflicts. In almost every one of these cases, American soldiers suddenly found themselves in asymmetric and intercultural combat. They were rarely prepared for either. The U.S. military’s struggle in these conflicts to achieve success at the operational- and strategic-levels of war reflects this lack of preparation. Given the Army’s current focus on large-scale operations against symmetric threats, this trend is unlikely to change in the near future. Despite the Russian invasion of Ukraine and concerns about Chinese expansion, it is still likely that when U.S. soldiers next face combat, their adversary will have the face of an Iranian militiaman, a Yemeni insurgent, or another combatant with an equally unfamiliar profile. For military professionals seriously interested in readying their soldiers to meet that adversary, *The Other Face of Battle* should be required reading. ■

# Zelensky Echoes Churchill in Speech to U.K.'s Parliament

Ukrainian President Volodymyr Zelensky received a standing ovation after he quoted Winston Churchill and William Shakespeare in a speech to the United Kingdom's House of Commons 8 March 2022, CNN reports.

"We will fight to the end," Zelensky said through an interpreter. "We will not give up and we will not lose. We will fight until the end at sea, in the air. We will continue fighting for our land, whatever the cost."

*Extract from a speech given to the British House of Commons by Prime Minister Winston Churchill, 4 June 1940, calling for total resistance against Nazi Germany immediately following the successful rescue of the British army from Dunkirk.*

"Turning once again, and this time more generally, to the question of invasion [by Axis forces led by Germany], I would observe that there has never been a period in all these long centuries of which we boast when an absolute guarantee against invasion, still less against serious raids, could have been given to our people. ... There was always the chance, and it is that chance which has excited and befooled the imaginations of many Continental tyrants. Many are the tales that are told. We are assured that novel methods will be adopted, and when we see the originality of malice, the ingenuity of aggression, which our enemy displays, we may certainly prepare ourselves for every kind of novel

stratagem and every kind of brutal and treacherous maneuver. I think that no idea is so outlandish that it should not be considered and viewed with a searching, but at the same time, I hope, with a steady eye. ...

"I have, myself, full confidence that if all do their duty, if nothing is neglected, and if the best arrangements are made, as they are being made, we shall prove ourselves once again able to ... ride out the storm of war, and to outlive the menace of tyranny, if necessary for years, if necessary alone. At any rate, that is what we are going to try to do. That is the resolve of His Majesty's Government—every man of them. That is the will of Parliament and the nation. The British Empire and the French Republic, linked together in their cause and in their need, will defend to the death their native soil, aiding each other like good comrades to the utmost of their strength. Even though large tracts of Europe and many old and famous States have fallen or may fall into the grip of the Gestapo and all the odious apparatus of Nazi rule, we shall not flag or fail. We shall go on to the end, we shall fight in France, we shall fight on the seas and oceans, we shall fight with growing confidence and growing strength in the air, we shall defend our Island, whatever the cost may be, we shall fight on the beaches, we shall fight on the landing grounds, we shall fight in the fields and in the streets, we shall fight in the hills; we shall never surrender." ■

Sources: Grayson Quay, "'We Will Fight to the End': Zelensky Quotes Churchill in Speech to U.K. Parliament," Yahoo News, 8 March 2022, accessed 1 April 2022, <https://news.yahoo.com/fight-end-zelensky-quotes-churchill-211402255.html>; Winston Churchill, "We Shall Fight on the Beaches" (speech, House of Commons, 4 June 1940), accessed 1 April 2022, <https://winstonchurchill.org/resources/speeches/1940-the-finest-hour/we-shall-fight-on-the-beaches/>.



**Previous page:** Then Prime Minister Winston Churchill makes a speech in Uxbridge, Middlesex, England, during the general election campaign on 27 June 1945. (Photo courtesy of the Imperial War Museums). **Top to bottom:** Ukrainian Territorial Defence Forces members train to use an NLAW antitank weapon in Kyiv outskirts, Ukraine, 9 March 2022. (Photo by Efrem Lukatsky, Associated Press). People look at the gutted remains of Russian military vehicles on a road in the town of Bucha, close to the capital Kyiv, Ukraine, 1 March 2022. (Photo by Serhii Nuzhnenko, Associated Press). A civilian trains to throw Molotov cocktails to defend Zhytomyr, Ukraine, 1 March 2022 as Russia's invasion of Ukraine continues. (Photo by Viacheslav Ratynskiy, Reuters/Alamy)



AN ARMY UNIVERSITY PRESS PUBLICATION

<https://www.armyupress.army.mil>

PB-100-22-05/06

Headquarters, Department of the Army

Approved for public release

Distribution is unlimited—Distribution A