



# **Security Assistance** **U.S. and International** **Historical Perspectives**



**The Proceedings of the Combat Studies Institute  
2006 Military History Symposium**



**Kendall D. Gott**  
Managing Editor

**Michael G. Brooks**  
General Editor



Combat Studies Institute Press  
Fort Leavenworth, Kansas



US Army Training and Doctrine Command  
Fort Monroe, Virginia  
and  
Combat Studies Institute  
US Army Command and General Staff College  
Fort Leavenworth, Kansas

*Present*

***Security Assistance:  
U.S. and International Historical Perspectives***

Kendall D. Gott  
General Editor

8-10 August 2006  
Frontier Conference Center  
Fort Leavenworth, Kansas



Combat Studies Institute Press  
Fort Leavenworth, Kansas

Library of Congress Cataloging-in-Publication Data

Security assistance : U.S. and international historical perspectives / Kendall D. Gott, managing editor ; Michael G. Brooks, general editor.

p. cm.

Other title: Proceedings of the Combat Studies Institute 2006 Military History Symposium. "8-10 August 2006, Frontier Conference Center, Fort Leavenworth, Kansas."

1. Military assistance, American--History--Congresses. 2. Military assistance--History--Congresses. I. Gott, Kendall D. II. Brooks, Michael G. III. United States. Army Training and Doctrine Command. IV. U.S. Army Command and General Staff College. Combat Studies Institute. V. Title.

UA23.S3948 2006  
355'.0320973--dc22

2006034668

CSI Press publications cover a variety of military history topics. The views expressed in this CSI Press publication are those of the author and not necessarily those of the Department of the Army or the Department of Defense.

A full list of CSI Press publications, many of them available for downloading, can be found at <http://www.cgsc.army.mil/carl/resources/csi/csi.asp>.

---

For sale by the Superintendent of Documents, U.S. Government Printing Office  
Internet: [bookstore.gpo.gov](http://bookstore.gpo.gov) Phone: toll free (866) 512-1800; DC area (202) 512-1800  
Fax: (202) 512-2250 Mail: Stop IDCC, Washington, DC 20402-0001

ISBN 0-16-077346-6

## Contents

Foreword .....	vii
Keynote Address	
Lieutenant General David H. Petraeus .....	1
Question and Answer .....	25
Day 1, Panel 1: Historical Overview	
<i>The Evolution of Military Advising and Assistance, 1815-2005</i> by Dr. Donald Stoker .....	33
<i>Army-based Overseas Security Assistance Training and Assistance Over the Last Twenty Years</i> by Mr. Kenneth Haynes .....	45
<i>Middle Eastern Cultural Impacts on US Security Assistance</i> by Major Hank Kron .....	55
Question and Answer .....	75
Day 1, Lunchtime Session	
<i>After Saddam: Stabilization or Transformation?</i> by Major William Shane Story .....	79
Day 1, Panel 2: Central Asia Perspective	
<i>Comparative Great Power Experiences in the Training of Indigenous Forces: Central Asia, India, and Haiti</i> by Dr. Robert Baumann .....	93
<i>Soviet Military Assistance to the Democratic Republic of Afghanistan After the Withdrawal of Soviet Forces, 1989-1991</i> by Dr. Jacob Kipp .....	105
<i>US-Central Asian Security Cooperation: Miscommunication, Misunderstanding &amp; Missed Opportunities</i> by Mr. William Lambert .....	123
Question and Answer .....	161

Day 1, Panel 3: Breaking Out of the Box

<i>If You Build It, They Will Come: The Case for Establishing Standing Reserve Civil Affairs Packages for Nation-Building and Security Assistance Operations</i> by Captain Kris Alexander.....	167
<i>Send in the Amateurs! Recruiting from the Private Sector to Accelerate Nation-Building: The Experience of the Afghan Reconstruction Group</i> by Mr. Thomas Berner, Esq. ....	175
<i>Developing Weapons of Mass Construction: Expanding the Role of Provincial Reconstruction Teams in Sub-National Security Assistance</i> by Mr. Roberto Bran .....	203
<i>Permanent Implants: Improving Embedded Training Team Support to Indigenous Military and Security Forces</i> by Major Albert Tabarez .....	211
Question and Answer .....	223

Day 2, Featured Speaker

<i>Security Assistance in the Vietnam War</i> by Dr. Lewis Sorley .....	233
Question and Answer .....	249

Day 2, Panel 4: Africa/Malaya Perspectives

<i>CORDS and the Vietnam Experience: An Interagency Organization for Counterinsurgency and Pacification</i> by Dr. Richard W. Stewart .....	255
<i>East to East: PRC Security Assistance to the Republic of Tanzania, 1964-76</i> by Dr. Donovan Chau .....	271
<i>Building the Malayan Army and Police—Britain’s Experience During the Malayan Emergency 1948–1960</i> by Dr. James Corum .....	291
Question and Answer .....	315

Day 2, Lunchtime Session	
<i>US–Iraqi Joint Operations</i> by Lieutenant Colonel Keven Farrell.....	325
Question and Answer .....	359
Day 2, Panel 5: Western Hemisphere Perspective	
<i>The Alliance Transformed: US–Colombian     Security Cooperation, 1950–1960</i> by Dr. Bradley Coleman .....	365
<i>Employment of the Philippine Constabulary (1901–1917)     and Haitian Gendarmerie (1916–1934) in Civic Tasks,     Such as Anti-Corruption, Against the Background of     Counterinsurgency Campaigns</i> by Captain Robert Mihara .....	391
<i>Lessons from the US Advisory Efforts in El Salvador</i> by Dr. Lawrence Cline .....	421
Question and Answer .....	435
Day 2, Featured Speaker	
Dr. Michael O’Hanlon .....	441
Question and Answer .....	453
Day 3, Panel 6: Middle East Perspective	
<i>Security Assistance and Counterinsurgency:     The British Experience in Oman, 1964–1975</i> by Mr. Walter C. Ladwig III .....	473
<i>The Role of Advisory Support in the Long War     Against Terrorist Extremist Groups</i> by Dr. Thomas Mahnken .....	505
Question and Answer .....	515
Day 3, Panel 7: US Security Assistance to Romania	
<i>A Historical Overview of the Romanian     Diplomacy and Great Power Security</i> by Mr. Joseph M. Isenberg .....	519

Day 3, Panel 7: US Security Assistance to Romania ( <i>cont'd</i> )	
<i>Post cold War US Security Assistance to Romania and the Problem of the 'Double Security Guarantee'—A Romanian Perspective</i>	
by Mr. Adrian Florea .....	545
<i>A Transformational Approach to Security Assistance: The Case of Romania</i>	
by Major Drew Schumann .....	567
<i>Why Is There No Anti-Americanism in Romania Today? A Cultural Perspective On Security Assistance: the Case of Romania</i>	
by Mr. Silviu Hariton .....	581
Question and Answer .....	595
Day 3, Lunchtime Session	
<i>Building Iraqi Security Forces From the Bottom Up: Task Force 2-2 and the 205th Iraqi Army Battalion in Muqdadiyah, Iraq</i>	
by Lieutenant Colonel Peter Newell .....	599
Day 3, Featured Speaker	
<i>Vietnam and Iraq: Why Everything Old Isn't New Again</i>	
by Dr. Andrew Krepinevich .....	647
Question and Answer .....	667
Appendix A: Conference Program .....	675
Appendix B: About the Presenters .....	683



## Foreword

These proceedings are the fourth volume to be published in a series generated by the Combat Studies Institute's annual Military History Symposium, this year sponsored by the US Army Training and Doctrine Command (TRADOC). The Annual Military History Symposiums provide a forum for the interchange of ideas on historical topics pertinent to the current doctrinal concerns of the United States Army. In pursuit of this goal the Combat Studies Institute brought together a diverse group of military personnel, government historians, and civilian academicians in a forum that promoted the exchange of ideas and information. This year's symposium, hosted by the Combat Studies Institute, was held 8-10 August 2006 at Fort Leavenworth, Kansas.

The 2006 symposium's theme, "Security Assistance: U.S. and International Perspectives," was designed to present historical research, analysis and policy recommendations on the topic of Security Assistance and Training Indigenous Forces. While much attention was paid to the U.S. military's historical practice of security assistance operations and policies, discussions of the role of other agencies of the U.S. Government in security assistance as well as the international experience with security assistance programs were included.

This year we were fortunate to have Lieutenant General David Petraeus address the symposium, bringing to bear his enormous recent experience in Iraq and his perspective as the Commanding General of the Combined Arms Center at Fort Leavenworth. Other featured speakers included Dr. Lewis Sorely, Dr. Michael O'Hanlon, and Dr. Andrew Krepinevich, each being leading experts in military history and national military policy. These proceedings also contain the papers and presentations of some two dozen participating panelists. It also includes transcriptions of the question and answer periods following the panelists' presentations. These materials can also be found at <http://usacac.army.mil/cac/csi/conference06.asp>. The symposium program can be found at Appendix A of this volume.

These annual symposiums continue to be an important annual event for those students and masters of military history who believe that the past has much to offer in the analysis of contemporary military challenges. The Army continues to derive important insights from non-military historians and thinkers. The attendees and recipients of the proceedings have uniformly found them to be of great benefit. We intend for the readers of this volume to find the experience equally useful. *CSI - The Past is Prologue.*

Timothy R. Reese  
Colonel, Armor  
Director, Combat Studies Institute



**The 2006 TRADOC/Combat Studies Institute  
Military History Symposium  
Keynote Presentation  
(Transcript of Presentation)**

**Lieutenant General David H. Petraeus  
Commanding General, US Army Combined Arms Center**

Well, good morning to you all, and for those from out of town, let me also say welcome to historic Fort Leavenworth. It is great to have you all here for what I'm sure will be a stimulating, productive, and enjoyable symposium. As has already been noted, the topic for this year's conference is clearly timely. I'm sure that given this superb group, the discussions will be lively.

Seeing such a wonderful audience, and recognizing that we are perilously close to achieving intellectual critical mass, especially in historians, reminds me of a story that I heard recently. It seems that a mid-level executive working at a large corporation was frustrated at being passed over for promotion year after year. Convinced that his lack of advancement was related to his inability to see the big picture in developing market analyses presented at corporate staff meetings, he decided to visit the local brain transplant center in the hope of raising his IQ enough to impress his bosses and secure that elusive promotion. Well, after a battery of physical and mental tests, he was accepted by the director of the center as an acceptable candidate for a complete brain transplant. "That's great," the executive said to the director, "but I'm a working man and I understand this procedure can be very expensive." "Well, it can be expensive," the director replied, "but the price is a function of which type of brain you select. For example, an ounce of television reporter's brains costs roughly \$2,000." "Gosh," the man exclaimed, "with a TV reporter's brain, I could capture global trends and reduce them to powerful sound bytes that are understandable to everyone. That would be terrific. But do I have other options as well, Director?" "Let me check," the doctor said, while flipping through the pages in his inventory notebook, looking for other suitable matches. "Ah," he said, "Here's a very good option—historians' brains. They run about \$7,000 an ounce." "Historian's brains," the executive replied with awe. "Why historians capture the events of a millennia in a single chapter. With skill and intellect like that, I could woo the executive board members with a clear, concise view of the big picture, all condensed to just a few PowerPoint slides." "Absolutely," the director observed with equal enthusiasm, "But here's one more match for you to consider—Generals' brains. They are priced at \$100,000 per ounce, and we just happen to have some in stock." The executive was astonished, "Get out of here," he said. "Do you have

any idea what I could do with an ounce of General's brains? Why, I'd be the marshal of the marketing department, the brigadier of the boardroom, the warlord of the executive committee. But," he asked after a short pause, "why on earth do you charge \$100,000 for only one ounce of General's brains, when the others are priced so much more reasonably?" "Oh," the director responded, "that's simple. Do you have any idea how many Generals it takes to get an ounce of brains?"

That's just a joke now. And I assure you, that those of us here at CAC (Combined Arms Center) don't think the brains of historians should be valued anywhere near so modestly, though perhaps the cost of talking head brains was a bit steep.

Well, I'm approaching ten months in command of the Combined Arms Center in Fort Leavenworth, a position in which I'm privileged to oversee all the great historians at the Combat Studies Institute (CSI), an organization that has, of course, pulled together this conference. It is the historical organization in our Army that focuses on the area between the rapid collection and dissemination of lessons learned, which is performed by our Center for Army Lessons Learned, and the official histories published by the Army Center for Military History. So CSI primarily researches historical topics pertinent to contemporary concerns of the Army. The subjects we'll discuss over the next few days clearly are of current interest, and ones for which I believe helpful lessons can, indeed, be found in contemporary history. And even though my graduate degrees are from a program that combined International Relations and Economics, I hope you know that I do appreciate having so many distinguished historians here for this symposium.

But that, too, brings to mind another story. A comment by then Army Chief of Staff General Gordon R. Sullivan while addressing the faculty of the great Department of History at the US Military Academy during the department's dining-in. "Tonight," he observed, "with a group of distinguished historians, I'm sure I won't experience the internal debate with which I often struggle. In that debate, one voice tells me that a man with a history degree is like a fish with a bicycle, and another contends that a good Political Scientist never let a contrary fact get in the way of a good generalization."

Well, General Sullivan's observations underscore the fact that history is a discipline to which we often look for illumination of the paths we might take into the future. History does not, to be sure, have all the answers. However, it clearly can help us remember to ask the right questions. And I think CSI does have it right in its motto when it notes that "the past can be prologue."

The study of history and reflection on what it can offer us are thus important endeavors, both for those who wear the uniform, and for those who make national policy. Indeed, there are countless admonitions about the value of soldiers also being scholars. The most famous, perhaps, was British General Sir William Butler's remark in 1889, "The nation that insists on drawing a broad line of demarcation between the fighting man and the thinking man," he wrote, "is liable to find its fighting done by fools, and its thinking done by cowards." That caution is familiar to all of us; however, of relevance to us today is the context in which Butler offered it, and which I didn't know, in fact, until preparing for this presentation. Butler's admonition was, in fact, offered in a biography of Charles Gordon, while writing about the need for a military commander to be prepared to lead civil reconstruction after a battlefield victory.

History, then, has enormous value to the soldier and to the statesman. Again, it doesn't point the way, but it does provide useful perspective to help guide the traveler seeking to blaze a new trail. In fact, I'd like to think that a modest knowledge of history, economics, and political philosophy stood me, and a number of other leaders, in good stead in the early days in Iraq. In particular, simple concepts from those academic fields, such as the rights of the minority, basic ideas of free market economics, and so forth, did indeed help illuminate the way for us, and we drew repeatedly on the intellectual capital that each of us had accumulated while at staff and war colleges, as undergraduate and graduate students, as instructors, as soldiers on operations and exercises, and often, most importantly, from our own personal reading.

History can also reassure you while actually engaged in a mission. In fact, I took considerable solace during my last tour in Iraq as the head of the so-called train and equip mission, in reading of the challenges encountered by the great T. E. Lawrence when he was embarked on his own train and equip mission in the Arab sub-continent during the First World War. Particularly in the late fall and winter of 2004, which for me was the toughest period I experienced, I took comfort in reading how Lawrence dealt with issues similar to the ones with which we were grappling. "See," I'd tell myself at night, "it's not just you, Dave. Even Lawrence encountered the same problems." That thought, together with the occasionally dense writing of some of Lawrence's observations, often helped usher me off to sleep at night in Baghdad.

And with the Iraq train and equip mission in mind, I want to launch off and offer a few observations that we've captured, indeed, to try to help illuminate the path for any future such mission. Again, I was privileged to head that mission, actually to establish the Multi-National Security Transition Command-Iraq (MNSTC-I) and

to head it for a little over the first 15 months of its existence. Also along the way, I picked up a second hat as Commander of the NATO Training Mission-Iraq—much more modest organization, both in terms of resources and in scope, but also another important endeavor.

I will now step away from the podium, take up the tool of the modern General in the battlefield, the laser pointer, and with PowerPoint ranger skills from the staff, provide this to you. There are countless lessons that you can learn from the experience. We've tried to winnow it down to somewhere around ten or so. In fact, I hope to have some good dialog here and perhaps to generate some additional ones driving it.

### **Understand the Scope and Complexity**

The first observation is such a mission, it is a truly enormous task. You have to understand the scope and complexity and challenges of it. We used to occasionally say it was like building the world's largest aircraft while some of the blueprints were still being finalized, while in flight, and while being shot at. It is a colossal undertaking. I will not even be able to impart to you today, frankly, how large it is, although I will try in a couple of different ways. This is, for example, vastly bigger than a typical security assistance mission, and needless to say, it's not something you can do on the cheap. If it is so colossally big and so enormously complex and challenging, then clearly you must have the resources for that. Again, you'd be amazed at the kinds of assets that you require for this, because what you're really doing is rebuilding the entire institutions encompassed by the Defense and Interior Ministries, all of them. If you think about not just building our Army in the United States, but all the different services and the Department of Defense, then you're starting to get it right, at least in terms of the defense side of the house. But you literally have to sit down and figure out with your host nation partners, no kidding, what it is. How are we going to organize this force? What are the tables of organization and equipment for every single one of the units? Then, how are you going to equip it? You have to advise each of the formations, all the way from the lowest battalion, all the way up to the Ministries. You have to help them train, and you have to rebuild enormous amounts of infrastructure. Just to give you a sense of that, just in the 15 or 16 months that we were together over there, we did \$2 billion of reconstruction of Iraqi Security Force facilities—rebuilding training centers, academies, headquarters, forward operating bases, logistical depots, and all the rest.

## Get the Initial Focus Right

In fact, you have to start out by focusing correctly right up front (Slide 1). You've got to ask some real serious questions. You have to determine, and ideally you do that determination in concert with, in coordination with host nation authorities. They may or may not be around, by the way, at the beginning when we went through this process during the first two months of which, I might add, I had a weekly secure video teleconference personally with the Secretary of Defense, it was very rigorous and demanding. I felt a little bit like ... what's that movie about that guy that keeps going through the same events day after day ... Groundhog Day. We were definitely in a Groundhog Day experience right there. But again, it actually went pretty well as we sorted out the first order questions. What are the tasks of the forces to be? What are these forces going to do for their country? Are they going to do internal security missions? By the way, as of July 2004, the Army units were not going to do so. The Army was designed as three light divisions that were going to protect the borders of the country.



## Get the Initial Focus Right



*The initial focus must be to determine (ideally, with host nation officials):*

- the major security tasks/missions to be performed (e.g internal security, border security, dignitary protection, counter-terrorism, etc., etc.);
- the field organizations required to perform those tasks, including how they need to be equipped;
- the combat service support elements needed to provide logistical support for the field and support units;
- the institutional elements required to train, educate, equip, direct, command, control, and develop policy for all the forces;
- the plans and programs to train and equip the forces and to create the logistical and command and control infrastructure;
- the requirements for physical infrastructure (unit bases, headquarters buildings, communications architecture/assets, training centers and ranges, branch school facilities, depots, maintenance facilities, etc.);
- the coalition capabilities, organizations, resources, advisor elements, etc. required to support all of the above.

*Combined Arms Center - An Engine of Change*



Courtesy of LTG David Petraeus, US Army

SLIDE 1

### *Major Security Tasks/Missions*

Well, we went to Prime Minister Allawi, who had just taken over in late June 2004, and asked as our first question, “Wouldn’t you like your army to be engaged in dealing with the insurgents who are tearing your country apart?” And, after some discussion, he and the new Minister of Defense agreed that probably would be a good idea. Working with each other closely, we then gradually expanded the planned number of divisions from three to ten, added a substantial Special Ops Force, aviation assets, a mechanized division, three wheeled armored vehicle brigades, logistical elements, branch schools, academies, and other enablers. In fact, now there is an Iraqi counterterrorist force, there’s a Secret Service look alike, border security forces, and of course, just about all of them are performing internal security missions.

### *Field Organizations*

So then, we asked together, “What kind of combat organizations and combat support forces do you need?” And we literally did a troop to task analysis, based on some assumptions. We did this in concert with the Iraqis, also in concert with the commanders of the forces who were on the ground, and the Coalition forces.

### *Combat Service Support Elements*

Then of course, we asked “what do you need to support them?” “What logistical elements?” “In fact, what is the logistical doctrine, by the way?” We brought in an organization from Australia. They anted up and were going to help us establish a logistical institute along with all the other branch schools that we’re helping Iraq build. And their first question to me was the right one. What’s the logistical doctrine of Iraq? I said, “Heck, I don’t know. Let’s sit down and do a little thinking about it.” It’s not the same as ours, I can tell you that much. We’re not going to have first, second, third echelon the way we do. We’re going to have to do fixed base logistics. It’s much more efficient. We can’t get to first, second and third echelon right now. That kind of discussion in excruciating detail, across the board, in every single area, is what is required.

### *Requirements for Physical Infrastructure*

Okay, once you sort these things out, how do you help the nation produce forces? What kind of elements, what kind of structures, and what kind of infrastructure do you need to train soldiers, sailors, airmen, marines, regular police, national police, SWAT teams, Special Ops forces, border elements, secret service units, and so on? By the way, training is different from educating. You also need to educate them.



In fact, there's a military academy now, staff colleges, junior and senior, and the war college is next. Similar academies have been established for police and border forces. All of those kinds of efforts were part of the whole.

#### *Plans and Programs to Train and Equip*

Then, how are we going to equip them? How do you plan to do command and control? That's at the high levels, and tactical levels. Again, how do they intend to work that? What kind of command and control structures, communications backbones, are we going to have—internet, intranet, microwaves, satellites, HF?

#### *Institutional Elements*

And by the way, what about institutional policies? Believe it or not, there was a point at which all we needed was 14 simple policies. These aren't simple. Who's going to promote people? Who determines who stays? Who gets to command an organization? Who can fire someone or relieve a commander? By the way, remember there's a little bit of "back and forth" going on during all this time between Shi'a Arabs, Sunni Arabs, Sunni Kurds, and to some degree Yezidi, Shabak, Christians, Turkomen, and others. So these are not quite simple questions in many cases. Policies are a very, very big deal. Again, who gets to go to the NCO Academy? Is it my brother-in-law, my tribal member, or the most professionally qualified Soldier? This kind of issue takes a little bit more energy and a lot more discussion than you might think.

#### *Coalition Capabilities, Organizations, Resources, Advisor Elements*

Then, having determined what you need, you've got to figure out how do you get there from here. The physical infrastructure piece I talked about is just one example of the categories, if you will, of what has to be built. Again, those [of you] from the Vietnam era, I think, would remember the kinds of extensive infrastructure that were built, but we haven't done anything like that since Vietnam. In some respects, there were things that we did in Iraq that weren't even done in Vietnam when it comes to reconstruction of the country overall. We certainly attempted to do that in Iraq, which is more akin to a post-World War II type of effort. And then, by the way, having determined what the country needs, you need to develop what you need on the Coalition side in terms of the resources, capabilities, the organizations, the advisors, the trainers, etc., to sort out all of the above. It's a very, very enormous effort to take on, but that's what you've got to do up front.

## But... Get After It!

All that takes time. We compressed it into several months to at least get a sort of baseline and a broad idea of what was needed—knowing that we would continue to refine the basic plan as we went along. But you can't wait during that time. You've got to be doing something in the meantime. And the fact is, you don't need every answer to start training infantry battalions (Slide 2). You need some very, very key policies. What will their composition be? How will they be recruited? What are the baseline tasks? What are the big concepts that will guide them? Is this going to be like daycare, i.e., are they going to walk to work in the morning and walk home at night? If so, they may not be there when you really need them, which proved true in April of 2004. Or are they going to be soldiers and we're going to have them live in compounds? But then you've got to build compounds, you've got to be able to feed them. You have to house them, clothe them, send them on leave once a month. That's how they get money home to their families, or else the families starve, and they'll take leave anyway. So again, you've got to work your way through these kinds of things.



### But... Get After It!

*Every detail of the final plan is not necessary before training/ equipping/rebuilding can begin; however, as the experience with the Iraqi Civil Defense Corps showed, basic concepts/ principles are necessary.*



Iraqi soldiers receiving basic ground combat skill training

*Combined Arms Center - An Engine of Change*



Courtesy of LTG David Petraeus, US Army

SLIDE 2

In May of 2004, after the challenges of early April, one of the issues we identified was the need for just ten basic principles for the force which at that time was called the ICDC, the Iraq Civil Defense Corps. Eventually it evolved into the Iraqi National Guard, and then actually was integrated into the Iraqi Army. There were varying approaches that had been taken throughout the country. In some cases, in the north and the south, we'd built bases, it was a soldier concept. In other cases, because of inability to construct infrastructure, it was more of a walk to work and then walk home, which again is difficult when you have crises. So you've got to sort out a few basic principles. What color is the uniform? I mean, it's some basic things like this.

### Lawrence Had it Right

Now, of course as you're doing this, right from the beginning, it's very, very important to try to avoid, if you can, the creation of a dependency culture (Slide 3). So the first time that you can get the local forces to do anything for themselves, then of course the better off you are—and they want that as well.



## Lawrence Had it Right



*"Do not try to do too much with your own hands... It is their war, and you are to help them, not win it for them." - T.E. Lawrence, "Twenty-Seven Articles," Arab Bulletin, 20 August 1917*

- Help, versus do
- Identify, assist, enable the good local leaders
- It is often better for Iraqi leaders to do something tolerably than for coalition leaders to do it perfectly

Combined Arms Center - An Engine of Change



Courtesy of LTG David Petraeus, US Army

SLIDE 3

## Money is Ammunition

I think you've heard this one before (Slide 4). It was interesting that when Ambassador Bremer came up to Mosul the first time in late May of 2004, things were going pretty well, actually. He asked what we needed, and I said, "Hey, all we need is money, Ambassador. Money is ammunition in this fight." You know, we could punch off a million dollar missile—actually about a \$550,000 missile—with a single radio call during the fight to Baghdad. And now here we are trying to get a few thousand dollars for school supplies or uniforms or what have you, and it takes forever to get it and there's not much available anyway. And in fact, he responded quickly. That was the genesis of the CERP program, the Commanders Emergency Reconstruction Program. We knew we had captured somewhere around a billion dollars, mostly by the 3d Infantry Division in Baghdad, but other units had all contributed to this big pool. We said, "How about unleashing that money, let us use that." And, in fact, he did get that done.

But you've got to find the organizations in the beginning that have the capacity and the capability to do something with it. In spring and summer of 2003 that was the Coalition force divisions; we could, in fact, take care of just about every kind of need. By the way, this is just one example of the kinds of more detailed lessons that we learned. And I could go ad nauseum into construction, for example. We ended up being the largest customer of the Air Force Center for Environmental Excellence. And we had them compete against the Army Corps of Engineers. It was very, very salutary. They have a business model that was very conducive to

**Money is Ammunition**

*In an endeavor like Iraq, money is ammunition; in fact, depending on the situation, it can be more important than ammunition.*

  
Train and Equip Program

  
Iraqi Civil Defense Corps  
Training, 2003

**Fund organizations ASAP that have capability and capacity, can spend efficiently, and can address emerging needs.**

**Use Indefinite Demand/Indefinite Quantity contracts with established providers (e.g. the Defense Logistics Agency) vice normal peacetime contract procedures.**

Combined Arms Center - An Engine of Change

Courtesy of LTG David Petraeus, US Army

SLIDE 4

what we were trying to do, which is speed over quality in some cases, and even over cost to some degree.

Peacetime contracting is enormously challenging in an endeavor like this, when you're trying to do stuff rapidly. In fact, lo and behold, the first contract that was let back in January of '04 by an organization of the Coalition Provisional Authority (CPA) went into litigation for six months right away, because of the challenges of doing peacetime contracting rapidly. What you run the risk of having happen is someone getting that contract who may or may not have a proven track record, because they came in with the lowest bid. You're not completely sure what you're going to get. We found it far more useful just to go to a very reputable supplier, in this case I offer the Defense Logistics Agency, to whom MNSTC-I went to repeatedly, and you get what's called an Indefinite Demand/Indefinite Quantity (IDIQ) contract, and you can just order to your heart's content, keep it going, you don't have to re-compete. You know you're going to get what you asked for when you need it, where you need it, and in good condition. So that's a very minor example of the kinds of detailed lessons learned that we're collecting and that are very, very important to us.

### **Build Institutions, Not Just Units**

Another key factor is the ministries in the government; you've got to have advisors for them in very substantial numbers because if you can't get the top right, over time what you build at the bottom will not be effectively used. In fact, it could be misused and the effort undermined (Slide 5). You've got to train the folks

**Build Institutions, Not Just Units**

*It is easier to help build battalions and brigades than it is to help build institutions; however, underdeveloped institutions will undermine development of units.*

**Sufficient advisors needed for institutions, as well as for units**

The slide features five small images: a soldier in uniform, a group of soldiers in camouflage, a group of men in suits at a podium, a group of people in a meeting, and a group of people in a meeting.

Courtesy of LTG David Petraeus, US Army

who are doing the ministry work, developing the policies, ensuring the troops are paid, arranging buying their logistics, getting the fuel for them, and all the rest of that. If you can't develop those, they can very much erode and undermine the development of the units. As I mentioned, the Ministry advisor effort originally was performed by another organization. We really thought it would be useful to unify that effort under MNSTC-I because, in fact, there was an inability to man it at the levels that were actually authorized, and with the skill sets that were needed. That's a place where our Reserve Component forces are fantastic. I had a guy who was a Vice President from Goldman Sachs as our Deputy Comptroller, a Lieutenant Colonel. (You talk about a pay cut, by the way. Vice Chairman Bob Homatz of Goldman Sachs actually paid the difference for him in the end, which was great.) But he was sitting there as our Deputy Comptroller, I would have loved to have contributed him to be the Advisor to the Deputy Minister for Finance. That opportunity has now opened itself up, and as I said, now we have about 200 people doing that work. The key is being ready to adjust as required, and not getting locked into something.

### **Partner with Security Forces**

That's not enough. You also need to partner with the security forces (Slide 6). In fact, now, at General Casey's direction, every single Iraqi battalion brigade head-



## Partner with Security Forces



*Because of their size and capability, transition teams should be complemented by partnering coalition forces with the Iraqi Security Forces operating in the coalition unit area of operations.*



Courtesy of LTG David Petraeus, US Army

SLIDE 6

quarters, division headquarters, national police organization, etcetera has a partner unit on the Coalition side. In some cases, a unit like the 101st Airborne Division right now in Iraq, has four Iraqi divisions with whom it is partnered, and a large number of Iraqi police elements as well, at the province level and below. That very much complements the efforts of the advisors, and has proven to be very, very important. It also is a natural link since they are all conducting operations in the same area, and because all of the Iraqi Army units and the national police units are under the tactical control at some level of various Coalition units.

### Be Ready to Adjust

You've got to go into this with an idea that you're going to have to adapt, adjust, change, and allow this to evolve, because you're going to learn stuff along the way (Slide 7). Fairly early on we recognized that the model for police training, for example, that had been imported from Kosovo, needed to be made more robust, needed more focus on survival skills, working in environments where there are improvised explosive devices, force protection of police stations, a lot of tasks that, frankly, weren't necessary in even a Balkans environment, but were critical to survival in Iraq. It actually extended the length of the course from eight weeks to ten weeks, but the increase was necessary and I suspect the length of training will continue to go up.

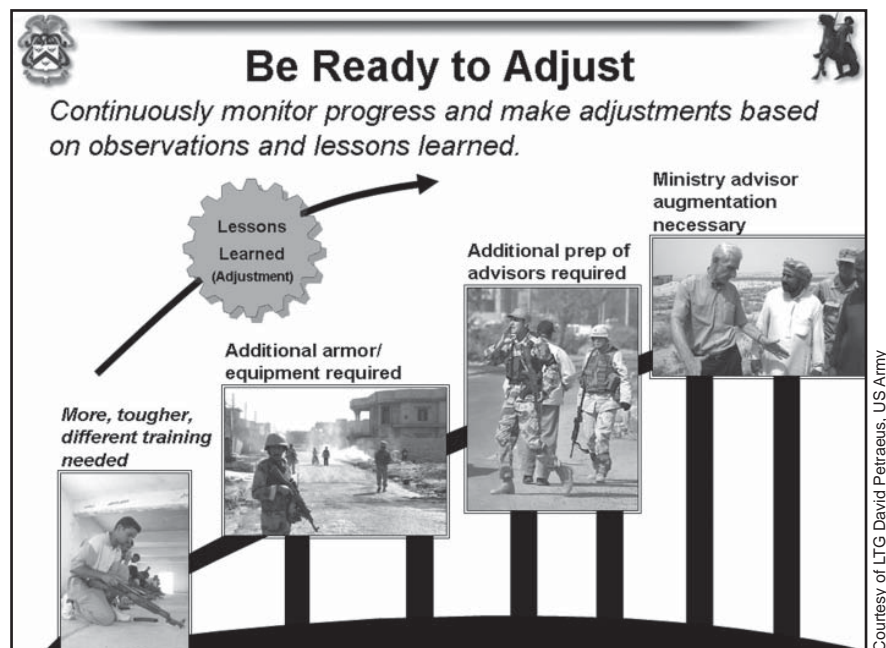

SLIDE 7

There was clearly recognition that the Iraqis needed additional armor and other heavy equipment. That was the genesis of the Iraqi Mechanized Division, of three brigades of wheeled armored vehicles, of the thousands of up armored HMMWVs. So again, this was pretty substantial. Even just going to additional numbers of heavy machine guns, RPGs, grenade launchers, helicopters, naval vessels, and so forth, over time, was a huge requirement. Another question one must ask is how are we doing against the ultimate force generation goals? One measure is how you are doing in terms of procuring the quantity of stuff; that information is useful, but not overly useful. You do have to keep track on how you're doing with construction, because it's literally a battle to get some of this stuff rebuilt.

## Develop Quantifiable Measures of Progress

### Force Generation

Then we asked, "Okay, where are we in relation to the [force structure] end state?" The end state continued to increase as well, as we made adjustments, or as the Iraqis came up with their own ideas (Slide 8). By the way, at various times, the good news was there was an Iraqi government. The "bad news" was the Iraqi gov-

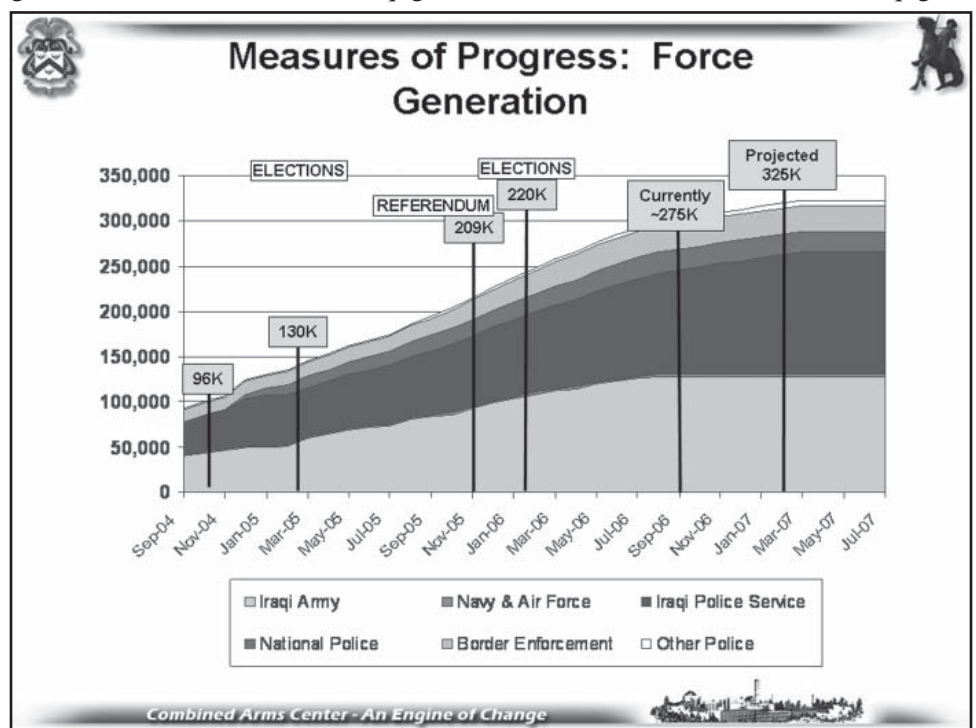

SLIDE 8



ernment had a few ideas of its own—and they weren't all in line with our thinking. At such times, you had to figure out, are we going to support them, resource them, or are we going to say no? Generally we supported and resourced.

*Equipment Issued*

Just to give you some sense, again, of the magnitude of the effort, the numbers here reflect the equivalent of equipping a force 2 and a half times the size of the entire British Army with body armor—which is what we have already done (Slide 9). This slide does include, by the way, equipment purchased by the Iraqis, and they have purchased a substantial amount of equipment on their own. There is now an entire Mechanized Division in the Iraqi Army, which was helped, by the way, by a gift. That's a place where NATO really did help; Hungary gave them 77 T-72 tanks, all refurbished and in very, very good condition.



### Measures of Progress: Equipment Issued

*Determining the standard is a function of the tactical situation, available funding, and the security force's pre-existing military expertise.*

<u>As of</u> <b>26 June 06</b>	Ministry of Defense Forces	Ministry of Interior Forces	Totals
Uniforms	450,000	350,000	800,000
Vehicles	13,000	9,000	22,000
Body Armor	100,000	150,000	250,000
Radios	18,000	52,000	70,000
AK 47s	100,000	110,000	210,000
Pistols	18,000	158,000	176,000
Ammunition	209,000,000	147,000,000	356,000,000
Helmets	126,000	28,000	154,000
Machine Guns	9000	3000	12,000

Courtesy of LTG David Petraeus, US Army

SLIDE 9

*Infrastructure Construction/Refurbishment*

There were substantial construction efforts (Slide 10). Border fortifications and camps, are just one example (Slide 11). Again, this is just one small example of the various types of construction. There are many others, for example, police academies, military training sites, branch schools, forward operating bases. They are all around the country. It just goes on and on, and you've got to keep track of all of it.

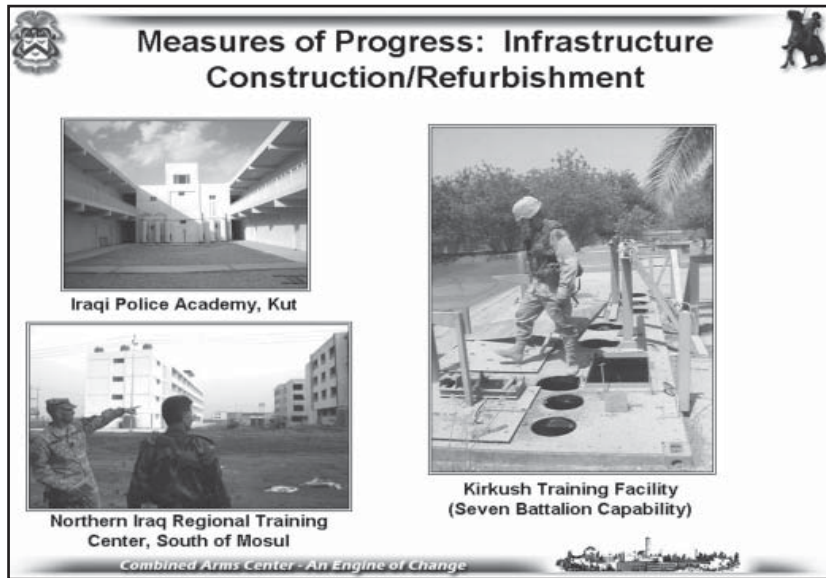

SLIDE 10

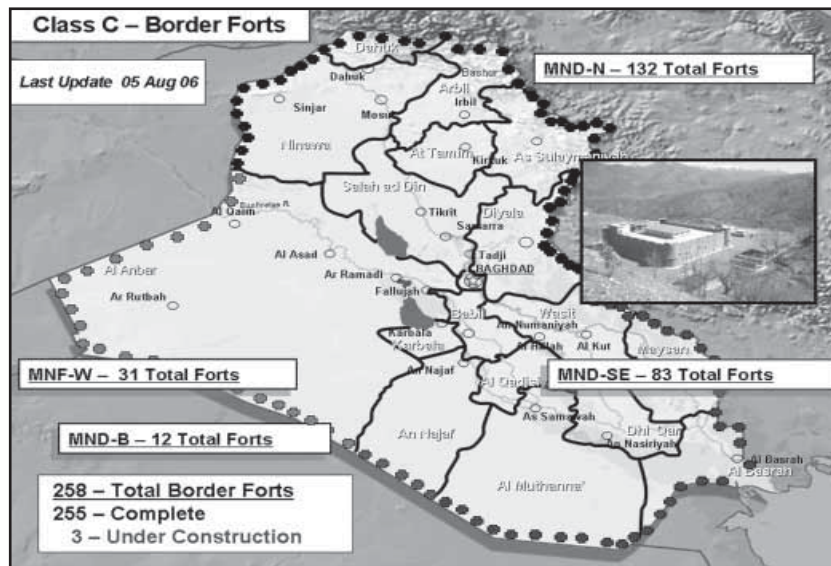

SLIDE 11

*Number of Trained and Equipped Security Forces*

You've also got to have a sense of how are we doing in terms of quality (Slide 12)? As a result we got into much more rigorous assessments, which were akin to the Unit Status Report used by the US Army. So you've got to have measures of progress, metrics. The truth is, these evolved as well. I used to have a saw tooth chart. We used to use it with Congress. It explained why the numbers of [trained Iraqi Security Forces] plummeted in August of '04 - when Secretary Rumsfeld said we should take the Facility Protection Security Forces out of that number—when we started with a more rigorous definition of what it meant to be trained and equipped. We defined how you got counted as trained and equipped. You have to have your individual kit. You've gone through the respective training for that particular component. So that was only one criterion.

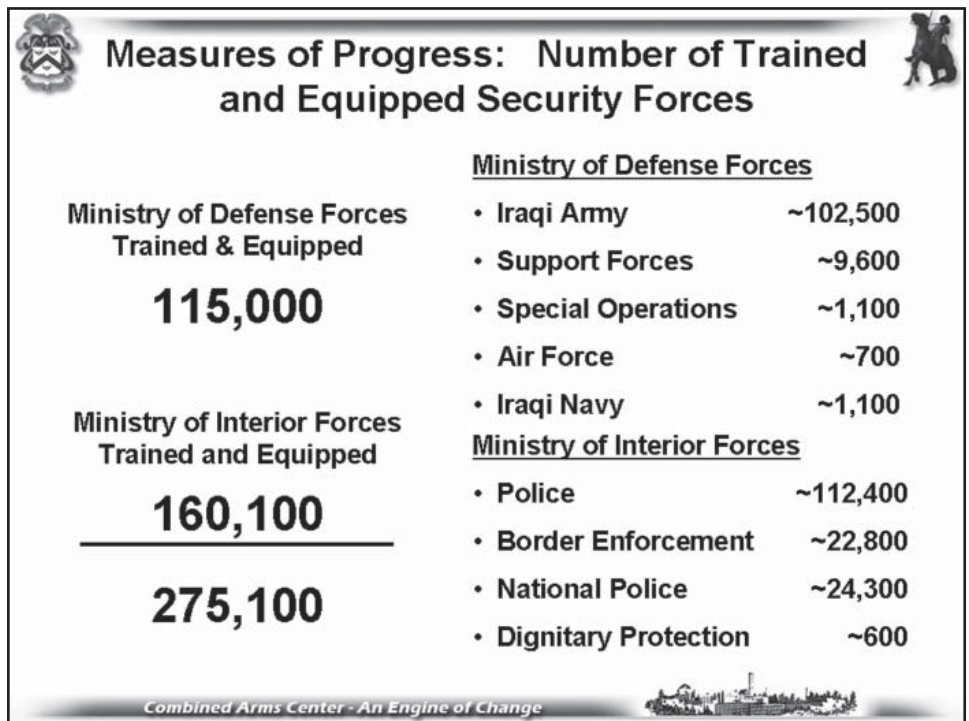

Courtesy of LTG David Petraeus, US Army

SLIDE 12

*Transition Readiness*

This was an effort to try to get a good bit more rigor into the process rather than just count somebody standing in formation who completed training (Slide 13). So now we're looking at such things as do they have the people that they need? Are they qualified? Do they have the training in command and control, and the hardware to carry it out, the radios and so forth? What's the state of their training on their mission essential tasks? Can they sustain themselves, both in terms of the equipment needed for sustainment operations and their training in the conduct of logistical operations? Do they have the combat equipment they need, and is it maintained? And then you must make a subjective evaluation of their leadership, given the huge importance of leadership. You can see the four overall readiness levels [we devised]: when they're just in the stages of being formed; when they graduate from their training (basic and then advanced training) and when they then go out to a forward operating base and fight alongside Coalition units, then at a certain point, when they can be assessed to be in the lead. That's the level at which they can take over their own area of responsibility, as well. And then when they become fully independent, which means they really don't need any Coalition support whatsoever.

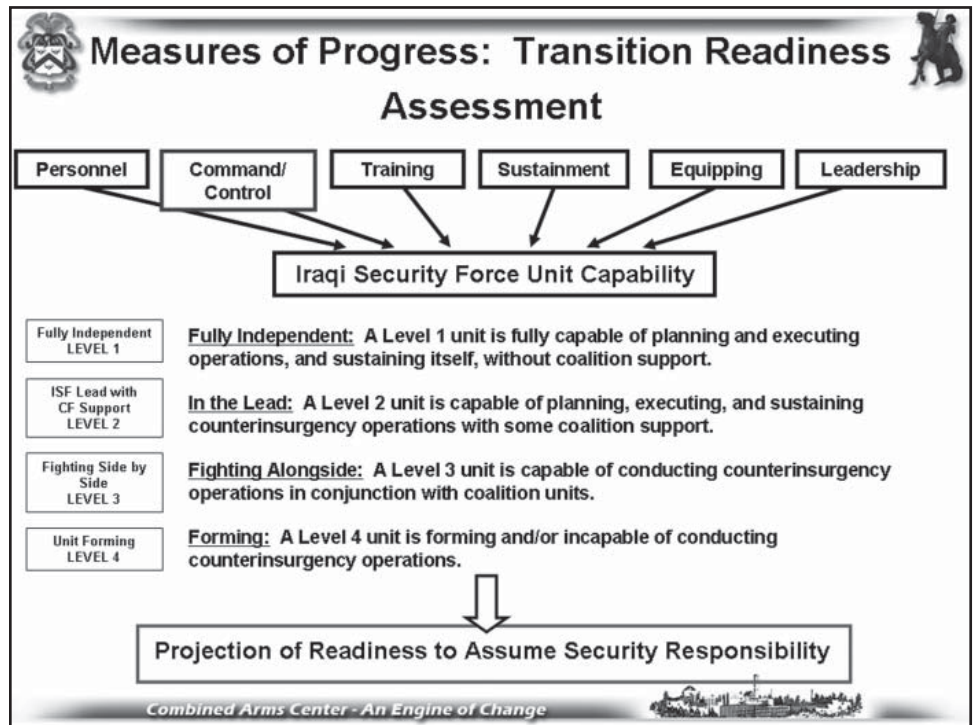

SLIDE 13

Then we said, “Okay, but can they take over their own area of responsibility?” A pretty substantial number of them have now done so (Slide 14). Some may have to go back to the Coalition [for support] at times because there are huge challenges—in Baghdad in particular—but there has also been pretty big progress. We don’t have the numbers on here because, again, that would make it classified. But you can get some sense, again, of the progress in the readiness of these units.

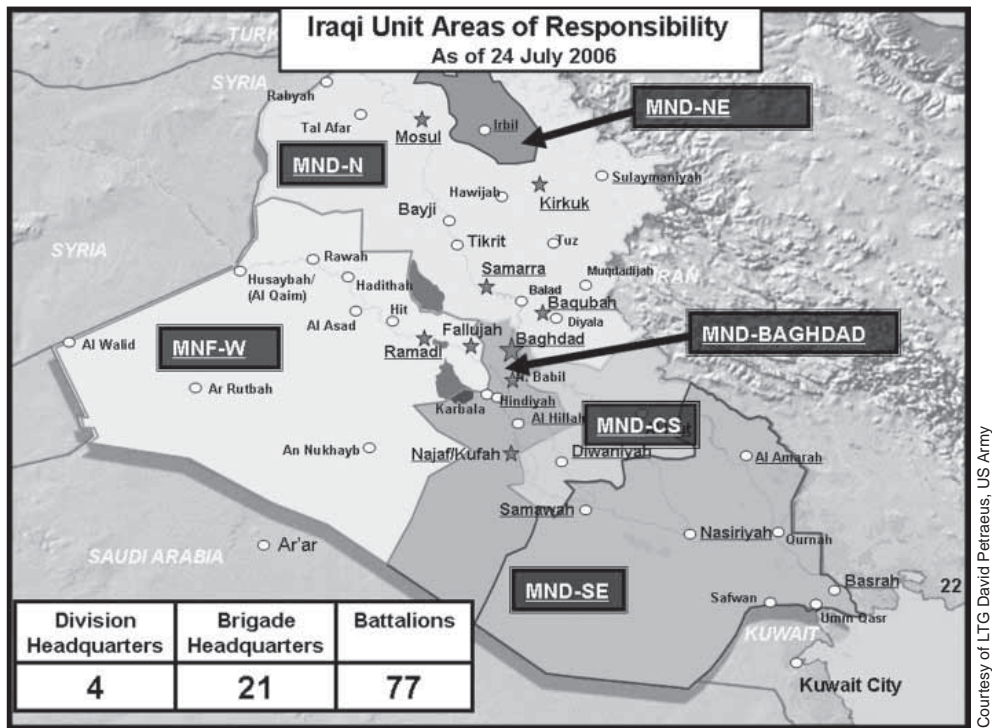

SLIDE 14

### Transition (Advisor) Teams are Key

Okay, now let’s talk about advisor teams which are also hugely important. You’ll hear acronyms like MiTT, which stands for Military Transition Teams, SPTT, Special Police Transition Teams, BTT, the Border Transition Teams, and there are others. There are now advisor teams, roughly 10 or 11 soldiers from Coalition countries [in each Iraq Army battalion], the bulk of them certainly the US. In the US areas, there are Army or Marine teams with every single battalion, brigade headquarters, division headquarters, ground forces headquarters, and, since MNSTC-I also picked up the Ministry advisor mission last early September of 2005,

there are teams with the Ministry as well. There are about 200 individuals now advising just in the Ministry of Interior and the Ministry of Defense, including the Joint Headquarters in the Ministry of Defense. They are also very, very substantial efforts, very, very important. I'll talk a little bit more about these later on.

As I mentioned, there is always a tension between training the ultimate warrior and preparing the ultimate advisor. The answer is, of course, you need some of each in the individuals who serve as advisors on the so-called "transition teams" in Iraq and Afghanistan. In fact, we're helping them get more language culture in functional area-specific training. CAC oversees, by the way, the Intelligence School and the Defense Language Institute, and that helps. The Intelligence School at Huachuca now has a Cultural Center of Excellence, which helps the entire Army. MNSTC-I had already created about 18 months ago an academy in Iraq, just north of Baghdad, which is the final ten days of preparation training for a newly arrived advisor, which tries to give them the final specifics about their own area, about Iraq, about the functions they'll perform, about the organizations they'll advise, and about the specific leaders with whom they'll serve. We'd already been doing quite a bit with the Center for Army Lessons Learned, collecting products for transition teams as well (Slide 15).

**Transition (Advisor) Teams are Key**

*And they need to have the right personnel and to be given focused preparation for the advisor mission.*

**Joint Center for International Security Force Assistance, Fort Leavenworth**

**Fort Riley (OIF) / Camp Shelby (OEF) 60-day training**

**Theater specific Functional Training**

- Intelligence
- IED
- Culture
- Language

**Phoenix Academy in Iraq**

**CALL Products for Transition Teams**

**HANDBOOK**

**SLIDE 15**

Courtesy of LTC David Petraeus, US Army

Recently the Vice Chief of Staff of the Army put out a memorandum that said the advisor mission is the most important mission we have and to resource it accordingly. Students here at the Staff College, and students at the Career Courses, have the message, and many of them will be going off and doing those missions. As a result, many more of the advisors will be active duty commissioned and noncommissioned officers. The idea is to professionally reward them for doing this, and not do what, in some cases, we did in Vietnam, which was send the message that advising was not an important assignment. We certainly don't want that kind of impression created; in fact the Vice Chief's direction obviously is the opposite of that.

It is also important to realize that you can't forget the intangibles of an Army, such as the Soldier's oath (Slide 16) and a host of other initiatives. You have to inculcate values. There's actually a Center for Leadership and Ethics in Iraq now. In fact, we helped [form] that with our Center for Army Leadership. And a member of our staff college instructors are over in Iraq right now trying to get a plane back after having spent several weeks at the Iraqi staff colleges, helping them, too. You have to build the institutional side of security forces. Arguably, that's more important than all the rest of this. If you can't get the professional ethic right and that kind of approach embraced, then again, there will be challenges down the road.

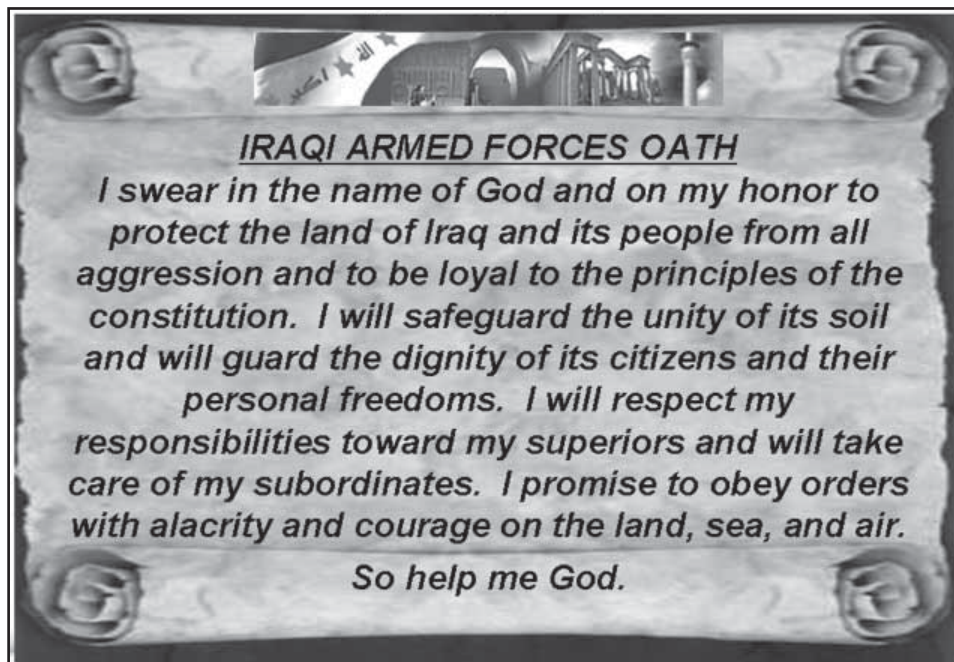

Courtesy of LTG David Petraeus, US Army

SLIDE 16

## Success Depends on Iraqi Leaders

I think everybody recognizes clearly that, at the end of the day, success depends on local leaders (Slide 17). Let me talk about that briefly.



### Success Depends on Iraqi Leaders



*Success with the Iraqi Security Force is, as time passes, increasingly dependent on Iraqi leaders.*

#### Four Levels of Leadership

1. National
2. Ministerial
3. Provincial
4. Security Forces



The key to developing Iraqi Security Forces is strong leaders; therefore, we must help establish the leader development programs, organizations, and systems needed to educate, train, and develop those leaders.

*Combined Arms Center - An Engine of Change*



Courtesy of LTG David Petraeus, US Army

SLIDE 17

### *National*

At the national level, of course, you've got to have leaders who are determined to keep the country together, to unify it. They also have to provide central direction that is meaningful to their forces. We tend to think the Iraqi Army, in particular, will do what it is told to do.

### *Ministerial*

The importance of the ministries can't be overstated either, and this is beyond just the ministries of Interior and Defense. In Iraq, for example all money flows through the Ministry of Finance, which receives substantial amounts of wealth from the oil that is being exported at very high quantities from the south and sporadically from the north. You've got to get the Ministry of Finance cranked up to



the point that it can get this money into the hands of the other ministries and where it can work for the Iraqi people.

### *Provincial*

Below the national level leaders and leaders of ministries are the leaders at the province level; again, they can certainly unhinge what it is you're trying to do if, for example, the Governor insists that the province Police Chief be sacked because he's from the Dawa Party instead of from SCIRI, or he wants a Kurd instead of an Arab. This kind of disruptive action can really have a huge impact, as you would imagine. So the province level is another important piece of this picture.

### *Security Forces*

And then, of course, certainly the leaders in the Security Forces themselves are of enormous importance. When you talk about that, once again, you've got to have leader development programs. And it's not just about training them on skills; it's about educating them in an Iraqi Arabic culture fashion, on values, ethics, and so forth, that will be constructive for the country. The fact is that, under Saddam, for example, the officers ate first and the troops got what was left—the exact opposite of the approach in most modern armies. Under Saddam, the money went to the officers, and if there was anything left for everybody else, hey, that was nice. If not, hey, tough luck. So again, breaking that kind of mindset is a big challenge. And it starts with education.

### **Be Patient**

Finally, you've got to have a degree of patience. It's very, very difficult when it's such a challenging endeavor as this, where the casualties continue to mount, where the violence continues at a pretty high level, and where we're spending vast amounts of money. But if we remember how long it took ourselves, just to form our own government back in the 1770's through 1789, and then look at how rapidly it's taking place in Iraq, despite the various challenges and so forth that

they've experienced, it's somewhat encouraging (Slide 18). And remember that 70 or 80 years after our constitution was ratified, there was a Civil War in the United States because we hadn't completely sorted out all the issues in our Constitution. This is not an argument to say things are going swimmingly or this is a piece of cake or anything else like that, but certainly it provides the kind of perspective and illumination that history can provide.

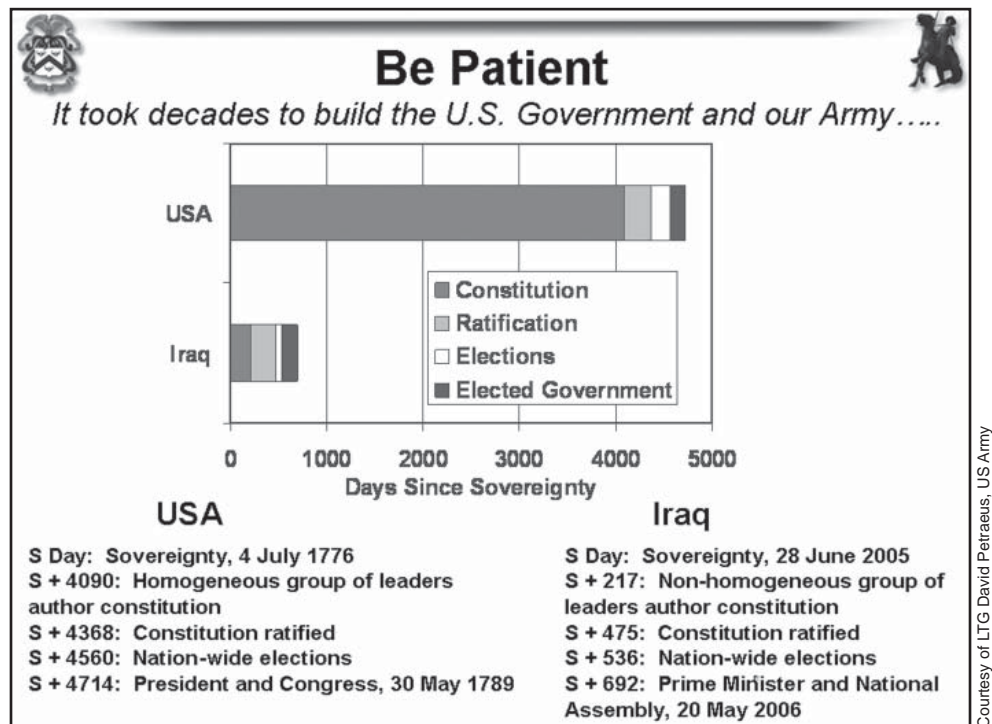

SLIDE 18

With that, I would welcome your questions, hoping to get some of this good dialog going that I think this group could foster.

## **Keynote Presentation Question and Answers**

(Transcript of Presentation)

### **Lieutenant General David H. Petraeus**

#### **Audience Member**

My name's Larry Yates, used to be with the Combat Studies Institute. You've mentioned cultural factors. Could you give us a generality to the degree that cultural and historical factors unique to Iraq had an impact on your mission? And if they did to some degree, to what degree were you prepared to deal with those?

#### **Lieutenant General David H. Petraeus**

I mean, clearly Iraq has extraordinary unique cultural ... you know, the biggest difference between what I did, or what any of us did, and what Lawrence of Arabia did, was that he was largely working with Sunni Arabs. I don't want to dismiss at all the challenges of the tribes. If you really get into what he was doing, there were incredible challenges of trying to get them, just for a day or two, to work together towards a common good, and that was not always easy. But certainly in Iraq you have a situation where you have, at the very least, three major ethnic groups all sort of cobbled together. Some may say ... whoever wants to argue about whether it's a legitimate or artificial or whatever boundary is drawn by Bell and Winston Churchill and others, that we will happily leave to the historians. But the fact is, we were operating in a space that included, particularly in Mosul, I might add, where we had very substantial elements of Sunni Arabs, Sunni Kurds in that area. By the way, they're not unified either. There's the Kurdistan Democratic Party (KDP) and the Patriotic Union of Kurdistan (PUK), and if you don't think there's some differences, just try to make a call on a cell phone bought in Dahuk if you're over in Sulaymaniyah. Certainly there is a Kurdish regional government, I know, and that's coming together, but remember that as recently as 1995, Saddam attacked into Irbil at the invitation of one to push out the other. So there's still a little bit of memory of some of that kind of thing. And then we had some Shiite. We certainly had a very prominent group of Christian minorities there. We had Yezidis, who I'd never heard of before in my life. The Kurds will say the Yezidis are Kurds. The Yezidis will hand you a book, then, that says life under the Kurds, which they did. There were Turkiman, particularly again ... and what you have is you have little communities in which they will be the majority. So you have a Christian city of Karakush. You have a Yezidi city just south of it. You have a substantial Turkiman population in Tall' Afar, and so forth. And then you have tribes. I don't know if any of us appreciated the challenges in operating with tribes, in particular, and it was very easy to align yourself with one tribe and realize that, heck, this is not the majority element of even that particular tribe. There was a Sunni tribe, for example, very,

very large up in Western Nineveh province, from which the eventual President, Sheikh Gazi al-Yawer came, and there was this guy from Chicago that was one of the Sheikhs. And we all loved him because he spoke English and he was a great guy, and to our surprise, a month or so later we realized he was from the minority faction of that tribe, and in fact, the majority faction was returning from London that afternoon. So again, you've got to get that kind of stuff sorted out.

We did a lot of on-the-job training and learning and all the rest of that. I think you can study this stuff a fair amount, but until you've actually been immersed in it, until you've lived it, until you've operated in it 24 hours a day for weeks and months on end, I think it's tough to really appreciate those various challenges. You can certainly learn the names, learn the definitions, learn some of that. But again, you've got to get in there and live it. And you have to then recognize when people are trying to outflank you or make sure that you don't end up with a battalion commander because this guy nominated him and he's not representative. So you get vast challenges like that. And everybody is your best friend, particularly when you're the man. Tongue in cheek, I said one time to somebody, unfortunately it was ... a Washington Post reporter had a headset on, but after we'd opened a border with Syria, presented a diplomatic note to the stunned Syrian border guard, which we asked him to take to Damascus to announce that we'd reopened an international border ... we did it all legally, by the way, and very much within International Law. In fact, it was right up at Rabia here. It was a pretty big day. All the Sheikhs gathered, they were all happy because we had a lot of trade going again. I mean the trucks had been lined up already in anticipation, and I said, "Boy, this is unbelievable. Sort of like being a cross between being the Pope and the President." Wish I hadn't said that with him having the headset on because, of course, I had to read about it in the Washington Post the next day. I'll never live it down with my classmates. But I mean, when you're in that position, you have to recognize that and recognize that everyone is a chameleon in a culture like this. It is also a culture that has been one of denunciation, really, is the only way to put it for decades under Saddam. And again, just trying to appreciate all of that when you're operating, and it takes awhile.

On the other hand, of course, you know there's some wonderful qualities about that particular culture. The way they're hospitable. Frankly, a culture of courage at various times. Jim Kauffman, when he was awarded his Distinguished Service Cross, asked that he have all the commandos with whom he had fought that day surrounding him. It was a pretty emotional moment. And again, they can do extraordinary stuff when provided great leadership. But leadership is a key component. We also used to call it the loudspeaker society. People listen to those loudspeakers, whether they're on a mosque, whether they're in the hand of a leader,

whatever it may be. That was the reason Saddam used to go on TV every night for two hours or so, just again, because they actually did listen and often would do what it was that he told or asked them to do. So, that's the kind of environment you're operating in. People ask me, "What prepared you for that, if anything?" Boy, I was stumped for a second, and I said, "Well maybe it was going to a civilian graduate school." A lot in here will appreciate ... in fact, a lot of us argue that to help our Army produce flexible, adaptable leaders, what we really need to do is get people out of their intellectual comfort zone. So we've recognized, for example, in the Command General Staff College, we can do all we want to, we can put the most provocative speakers on the stage that can challenge them intellectually and everything else, but the end of that 90 minute lecture, they're all going to go to the coffee pot together and say, "Man, wasn't that a load of horse hockey?" "That guy is off the wall." They'll skewer him in an ad hominum attack and feel good about it and head off to the gym.

So how do you get people out of their intellectual comfort zone? Well, one way is put them in a civilian graduate school and you find out that the whole world doesn't think the same way we do, and what was a real big debate in the Command and General Staff College, because I went from CGSC to a civilian graduate school, a big debate in CGSC doesn't even register out there. The example I always use is we were back in the days of nuclear strategy and deterrence and all this stuff. The nuclear priesthood, the wizards of Armageddon. And the big debate in CGSC that year was should you have 100 MX Missiles or 200 MX Missiles? And this was fighting words. And by God, it was irreconcilable. And I went to graduate school, and there were some incredibly bright people that said, "Well, maybe you should have no land-based multiple, independently targetable reentry vehicle missiles whatsoever." Or others that would say, "Well, yep, maybe you should have no land-based missiles whatsoever because they're destabilizing too because you can hit them. It's a temptation if you're going to get into a first strike situation." I mean others that said you should have no nukes, or at least no first use of nukes as a declaratory policy. Others that said you should have no weapons. I mean, you know, you can even find a few that would link arms and sing Kum-Ba-Yah. So you get the idea. It was a very, very helpful experience.

#### **Audience Member**

Debbie Goodrich. I'm a civilian historian and a journalist. Off the record, what are the challenges of dealing with the media? I know the modern Army faces a lot of issues that perhaps Lawrence of Arabia didn't have with instant communications.

### **Lieutenant General David H. Petraeus**

I'm glad you asked. I had a guy riding in my Humvee, as we attacked to Baghdad. You'll know him, three time Pulitzer winner, great historian, Rick Atkinson. In fact, he learned of his third Pulitzer in the middle of a dust storm, for the Army at Dawn book. The bottom line is, my sense was that the mainstream press certainly wants to get it right. Certainly wants to be accurate. And that's what we should judge them on. I had a Public Affairs Officer come to me early on, before we even went through the berm into Iraq and said, "Sir, I'm going to start grading the press on whether it's a positive story or a negative story." I said, "That sounds good." Three slides later, I said, "Wait and come back. Let's think about this here. Why don't you grade them on accurate and inaccurate? I mean, that's all we can ask them." It's up to us, if we crash a helicopter and they report it accurately, that's a negative story. But that's a lick on us too, and the American people deserve to know it.

Anyway, I actually did some thinking about this, interestingly, and I got the wife of a classmate of mine from West Point dragooned me into making a presentation in D. C. recently with Rick Atkinson. And my part of the presentation was observations on dealing with the press. You know, the press itself has gone through various emotions and it's own reactions to Iraq. It's taken some slings and arrows at various times, but what I'll do is show you what I think are the legitimate goals that we should have for the press, or at least the standards to which they should be held. I will tell you that we have tried to do that. I actually went to see, for example, the publisher of The Washington Post one time, Mr. Graham, over a particular article that I thought was a complete mischaracterization. Just flat The Post got it wrong. And they need to know that. And by the way, they want to know that. And we called another time, The Wall Street Journal really got something wrong. I mean it talked about how I was going to seize the TV towers in Mosul. Hell, I already had a battalion camped around it. We actually were securing it to begin with. We didn't need to seize it. And it was on a briefing I hadn't even received. And the guy didn't check the story with me before he published, and it caused enormous ... had to stay up basically all night trying to reassure everybody in Washington and all the rest of that stuff.

Okay, let's just whip through this. Next slide. You do need to read this. Can you see that in the back? That's Washington crossing the Delaware and there's a guy in the back from the press saying, "When's the war going to end? Is this a Civil War? Do you have a timetable? Are the British winning?" Next slide. This was just to show the ability the press had to take pictures. Every one of these was taken by Rick Atkinson, except for this one right here, I think. That was, by the way, right before Rick did the interview with General Wallace, in which General Wallace

stated, “Hey, this is a little bit different war than we expected.” And it ended up in The Washington Post and caused a little bit of a stir. But frankly, it was an accurate quote. But every one of these, this is the 3rd Brigade Commander, 1st Brigade Commander, 2nd Brigade Commander. That’s how close the press was with us. And we were planning, in each case, a different city in each case. Next slide. Accuracy. I talked about there’s a Wall Street Journal story that was just flat wrong. I mean no question about it. We obviously pushed back. They did publish sort of a retraction and update and admission they hadn’t got it quite right that first day. Next slide. These are just a couple of other ... I mean this is an interesting one. The great Sunday Times said ... at Fort Leavenworth, we were doing the Operational Plan for the second liberation of Baghdad. What we were doing is writing Field Manuals. Next slide. This is the one about correct characterization. This entire article, which was on the front page, above the fold, of The Washington Post, and characterizes the effort as “Mission Improbable” was based on one Iraqi company, which was clearly sub-standard, and one U.S. company, which definitely was sub-standard, and their interplay, which was sub-standard. So, I mean, it was a good ... but this was out of ... I don’t know, at that time, probably 800 Iraqi companies, and obviously it lacked a bit of the nuance of that particular effort. Next slide. Context. This is actually a good story in the sense that the press provided context. It talked about how there were some individuals shot when their car failed to stop at a traffic control point, which has been a huge challenge, and something that we have very much taken on in recent months, in particular, to try to shape the situations rather than have to do a shoot/don’t shoot at all. But in this case, it explains how it was that the soldiers came to do it, and it provided some useful context, and illuminated how difficult it is to operate in a country where anybody could be a suicide bomber, and any vehicle could be a suicide car bomb. Next slide. On the other hand, you know, you’ve got to do it. You can’t win if you don’t play. There was one week where we did interviews of every single one of these people right here. I’ve been on Al-Jazeera at least four times, and it used to really irk me when people would complain about Al-Jazeera. Because if you don’t like Al-Jazeera, then get on it. At least let them hear you. They will translate you correctly. They may ask a snide question and have a snide follow-up, but they will translate what you say correctly. So again, you can’t complain if you’re not willing to get in the arena. Next slide. These are just some stories that went pretty well. Michael Gordon even had a good story back in September 2004. This is a neat one here. It’s about Jim and me and some others. Next slide. You know that we’re making progress out here. That is Tom Ricks. Next slide. Now, on the other hand, you know you might end up on the darn cover of Newsweek and be ... again, your classmates will never let you forget that. Here’s the Pope and President one. So you take a risk. And you know, Bob Sorley and others who have been out there in the arena will tell you that a lot of times it’s a heck of a lot easier to follow the advice of the one he respect enor-

mously, General Abrams, who used to say, “When dealing with the press, never pass up the opportunity to keep your mouth shut.” The fact is, you can’t do that anymore. You’ve got to open your mouth. And by the way, this is not my Army. It’s America’s Army. And you all deserve to know who in the hell is doing some leadership in it. Next slide. In fact, that’s ... you’ve got to play. These people out here deserve to know who’s leading their man. Is he good enough, as Rick Atkinson used to say. And by the way, if we let them have access to these folks, by and large, it’s a pretty helpful endeavor. Next slide. By the way, you can’t put lipstick on a pig. When something is bad, and we had a terrible thing start off where a soldier of ours turned out to be of a different faith, threw a grenade into a tent before we even went through Iraq. And we decided, okay, what are we going to do? Are we going to stonewall it? No. Sergeant Major went out and said, “It’s time to move on.” You’ve got to address it. Next slide. There’s Abu Ghraib. I wasn’t directly involved in that, but certainly you get asked about it. I think you have to answer it. Next. Very, very important, I think we all know. For what it’s worth, at one point I did an Op Ed piece, and said, “Hey look, this is hard.” And I can assure you that I know what some others have said in the Oval Office and I know what I said, and I can tell you that we’ve been generally forthright. Next slide. By the way, this is a big one nowadays. This is something where I sent an email home to the families and I mentioned that we were working on a mid-tour leave program. I didn’t want to get hopes up, but I knew they were going to hear about it, so I tried to ease into it, tried to keep their expectations low. And of course, we read about that the next day in The New York Times. Next slide. And then don’t forget who’s in the back of your Humvee. That was Rick. Next. Okay, next. So that is sort of the press ... it is a fact of life. You’ve got to deal with it. You can’t win if you don’t play. You’re going to lose some, depending on how you define lose. And you just got to get after it.

### **Audience Member**

I was just curious about your rules, because by and large, I found that in the civilian part, despite the best efforts of the Ambassador, an awful lot of the rules about help, don’t do ... use wartime budgeting for contract procedures, none of those ever quite penetrated to the AID level, or to any of the permanent bureaucracies, and I was wondering, to what extent the military, which seems to have their feet on the ground and their head out of the clouds, they seem to have a much better idea about how to approach these things. And to what extent do you really have an interface with the various aid groups and can change their attitude?

### **Lieutenant General David H. Petraeus**

Well again, you saw that one lesson there that said get the money to the people that have the capability and capacity, capacity being the capability to do a lot. And I used to offer as an example, in the very beginning in Iraq, just to take Multi-



National Division North, which was largely the 101st Airborne Division, we had, I don't know, 22,000 soldiers. I don't know how many contractors. We had 250 helicopters. We had 6,000 or 7,000 trucks. We had water purification units, we had four engineer battalions, vertical, horizontal combat, you name it. Construction. We had an engineer group headquarters, which does assessment design contracting and quality assurance and has contractors and Class A agents, so they can actually do stuff, and they secure themselves and they have their own communications, and they can feed themselves. Not to mention three brigades, not to mention logistical support organizations, not to mention two signal battalions. You know, you could rebuild the infrastructure with that. And what we did was actually partnered every single ... we identified every element of the Iraqi structure in northern Iraq, and partnered somebody with it, including key individuals. I had a portfolio, my personal portfolio was the Governor of Nineveh province, and then the two key Kurdish leaders, the KDP President Barzani, and the PUK President Talabani, who is now the President of the country. And then others. There was Mr. Oil, there was Mr. Sports and youth and sports. You had all these, and you've got to have funny titles and all that. It's amazing what you can do. We had a big Public Affairs apparatus. They were making Public Service announcements. We had some comedians on the payroll, Iraqi comedians and producers. We sponsored Iraqi Idol and all this stuff. It was neat. In fact, of course you know, the ultimate competition night, the final selection of the Iraqi Idol, who, by the way, turned out to be a little kid who could cry on demand as he played something that looked like a ukulele. And it was really moving the first time you saw it. The fourth or fifth time it wasn't. But that night, the power went out, of all things. And we'd been pretty good with power up to that time. There was a blackout so we had to rerun ... I mean we got ... our hotline lit up because everybody wanted to watch Iraqi Idol. So you've got to get it to the organizations that can do stuff. AID has every great intention in the world, but they don't have their own security, they don't have their own comms. What I'm talking about is a very, very challenging security environment. This is not the Balkans where you can drive around in your own SUV. Maybe you've got a pistol when you're feeling very combatish or something like that. This is the real deal. This is where any vehicle on that highway could turn right into you and blow you up. Where you could be blown up by an IED at any point in time. It's just hard even to get Ministry Advisors to their ministries. And by the way, are they secure in that ministry? We built an entire compound, for example with MNSTC-I, just to house people that were going to support the Ministry of Interior. That's the level of effort you have to go to, in some cases. And the challenge is that outside the military that's very difficult. To be fair to Mr. Bremer, he has to come in, he's trying to create an organization as he comes in. And again, they can't do ... they don't have any of the organic assets that a military unit has. And that's the nub of the problem. AID was all over the country, particularly in the so-called easy days in

the beginning, but as it gets tougher and tougher and tougher, they need more and more assistance, more and more support, more and more security. It eats up more and more of the budget. You look at what proportion went for security for organizations that didn't have their own security, and it just kept creeping and creeping and creeping. And a huge amount was going to that. So that's the kind of challenge. By the way, Afghanistan had it easy. My perspective, it's certainly gotten tougher. I actually was asked ... the final pound of salt that the Secretary of Defense got from me was to ask me to come home through Afghanistan. So here I was ready to go home, and I should have known it because he was patting me on the back, literally, and shooed everybody out of the hard car ... it was in late August, right before we turned over in September 2005. Damn, I was feeling good. I was turning that back, hit it with both ends. And he said, "Yeah, I'm glad you're coming home through Afghanistan." I said, "Afghanistan, Mr. Secretary, I thought you'd forgotten that." But anyway, I came home and did a look at the Afghan Security Forces on the way home, and then reported out to them. I just was stunned. People could go to the Military Academy in a soft SUV. No long barreled weapons. It was just a real relief and very nice. So that's even in that environment, much less in the much more challenging situation that you find yourself in Iraq. So that's the context, that's the challenge. And I think you would just have to be prepared to deal with it. And every case is unique, as you well know. I mean, you all know the admonitions about that with respect to history, the great one by Mark Twain, you know the cat will never sit on the hot stove lid again, but it will never sit on a cold one either. And we have to recognize the context. The Provincial Reconstruction Team (PRT) concept, for example, which actually works pretty well in Afghanistan because you have a very light troop density over there and it's very helpful, you know it's arguable, the value. It's great to have the inter-agency people, but if it's going to be filled by soldiers, civil military folks or something like that, then you've got to look at what's the value of this?

Thank you very much.

## **The Evolution of Foreign Military Advising and Assistance, 1815-2005**

**Dr. Donald Stoker—US Naval War College, Monterey Program**

Nations seeking to develop and improve their military forces have often sought the advice of foreigners. Before 1815, military advice from abroad generally took the form of mercenaries, slaves, and former enemy troops pressed into service. General George Washington famously employed Baron von Steuben to instill some traditional military discipline into the ranks of the fledgling American fighting force. But with the rise of the modern nation state, the advent of the industrial revolution, and the accompanying professionalization of armies and governments, nations desiring military modernization and improvement began seeking more formal, professional advice to develop their military forces. This has usually meant receiving a foreign mission to directly instruct or advise in the development of domestic forces. Sometimes the nations dispatching the advisors do so for magnanimous reasons, but these states usually have policy goals beyond what the receiving nation is told or expects. But the states receiving the missions also have their own agendas (sometimes hidden ones), a point often ignored.<sup>1</sup> For example, in the mid-1920s, the Finns employed a British military mission, and it appears that their primary objective in receiving it was not to ask for British military advice but to strengthen their political relationship with London.<sup>2</sup>

Over the last two centuries, foreign military advising has evolved from ill-organized mercenary units to professional, government-sponsored teams, oftentimes driven by a desire to cultivate political and economic influence. In the twentieth century, they became tools for pursuing ideological aims (especially during the Cold War), nation building and modernization. The post-Cold War era added alliance integration to their tasks. But the post-Cold War era has also seen the increasing role of private corporations in military advising. These companies function as clearinghouses for military advice and quasi-mercenary forces, bringing the evolution of foreign military advising full circle, but with a modern twist.

Military advisors can be single soldiers or sailors dispatched to train the personnel of a foreign army,<sup>3</sup> or members of a large mission sent to examine and revamp the military structures of a friendly or client state. Generally, military advising falls into one of six categories: 1) Military advising as a tool of modernization; 2) Military advising as a tool of nation building; 3) Military advising for economic purposes or penetration; 4) Military advising as an ideological tool; 5) Military

advising as a counterinsurgency tool; or 6) Military advising for fun and profit: the corporate approach.

### **The Beginning: From Mercenaries to Formal Missions**

The era of the French Revolution and Napoleon upset the European domestic and colonial political apple carts. In the wake of Napoleon's fall from power in 1815, a number of newly independent nations began constructing domestic military forces. Egypt was one of these states seeking the institutionalization of military experience gained during the Napoleonic Wars and began by hiring French veterans. But Mehmet Ali, Egypt's new ruler, wanted to build a modern military force along western lines, so the Egyptians sought formal, official advice; the result: a French military mission. Egypt, by obtaining the mission, sought modernization of its military structures, but this also gave them an edge over their neighbors. Egypt became a regional military powerhouse that proceeded to devastate Ottoman power and conquer much of the Middle East. The importation of foreign military advice via a formal mission proved its worth.<sup>4</sup>

Though the Egyptians received a formal mission, this did not end their use of mercenaries. They continued this practice throughout the nineteenth century, with many former US Civil War officers finding employment in the Khedive's ranks.<sup>5</sup> Formal American military and naval missions arrived later.<sup>6</sup>

The experience of newly independent Chile mirrored that of Egypt in many respects. Together, these countries paint a clear picture of what was happening in the military forces of many small nations in the early nineteenth century. Gaining its independence from Spain in 1818, Chile had to build its own military forces and took a number of different routes to do so. Officers from foreign nations played an enormous role in this; 10 percent of Chile's pre-1885 officer corps came from abroad. Formal French and then German military missions followed. But Chile also produced something novel. Once they acquired European military know-how, they re-exported this to other Latin American nations via Chilean military advisory teams.<sup>7</sup>

China in the nineteenth century was also a fertile ground for mercenaries. One of the most famous of these was Frederick Townsend Ward, an American soldier of fortune who went to China in 1859. He fought for the Chinese government against the rebel Taipings and created an effective native Chinese military force led by foreign officers before his death in battle in 1862.<sup>8</sup>

The use of mercenaries did not end with the beginning of the twentieth century. From 1927-9, Chiang Kai-Shek employed a former German officer, Max Bauer, to provide advice on military and industrial modernization.<sup>9</sup> By the mid-1930s, a significant contingent of Germans were serving the Chinese Nationalists in a generally apolitical manner, an approach that would go into decline with the onset of the Cold War.<sup>10</sup> The Chinese Communists also received advice from foreigners, Soviet sponsored ones, though in a more formal manner.<sup>11</sup>

### **Missions for Modernization**

The desire to modernize was one of the primary reasons smaller nations in the middle and late-nineteenth century began requesting missions from the ‘Great Powers’ of Europe. Latin America and the Balkans became the primary fields for the exportation of military advice during this era. Though, there was also some important activity in Asia, particularly in China and Japan, Japan being the most famous and most successful example.<sup>12</sup>

Egypt, Chile, China, and Japan are important cases of states that sought foreign military advice in order to modernize their nations. Latin America in general has traditionally been a field for this. Before World War I, the Ottoman Empire famously received foreign military assistance from a number of powers. The British naval mission to the Sublime Porte has recently been the subject of detailed study.<sup>13</sup>

But there were other trends that arose as well, particularly after the end of World War I. First, pariah nations such as Germany dispatched military advisors and missions as a means of cheating on the armaments provisions of the Versailles Treaty. The cooperative agreement between Weimar Germany and Bolshevik Russia is well known, but the Germans also went to great extremes to cheat on the naval clauses of Versailles. They installed a ‘naval advisor’ in Finland, Karl Bartenbach, who guided Finland’s purchase of naval hardware from German puppet companies. These deals furthered the development of technologies indispensable to the birth of Nazi Germany’s submarine arm, while permitting the Germans to train the necessary cadre of a reborn U-boat force.<sup>14</sup> Modernization is still a role of missions, but instead of it being just the objective of the state receiving the mission, it is now also often the goal of the nation dispatching it.

### **Military Missions as Tools of Economic Penetration**

The modernization drives of less developed nations marched hand in hand with the use of missions as tools of economic penetration. The nations selling the

arms, usually European, but sometimes the US, generally wanted to place missions in foreign nations because they believed that it gave them leverage for the sale of arms. To the nation supplying the mission, the sale of weapons was far more important than the modernization of the military forces of the country in question.

Economic penetration as a primary role of missions became popular in the late nineteenth century and continued to be one of the major driving forces behind the dispatch of military missions between the World Wars. During this period, Latin America and the Balkans were key economic battlegrounds of the European powers seeking to sell arms, and the primary task of the various military missions was to insure market dominance for their respective national weapons firms.<sup>15</sup> The Baltic was also a fertile field for this in the post-World War I era, though the missions sometimes began as tools of alliance building and deterrence.<sup>16</sup> The various European missions to the Balkans are in need of further study.

### **The Ideological Struggle: The Role of Military Missions**

The Bolshevik rise to power laid the foundation for another new role for military missions: as prophets of revolutionary ideology. This began as early as 1921 when the Soviet Union dispatched military advisors to Mongolia. This quickly became a full advisory team that exercised immense influence and then control over Mongolian military structures, a Soviet officer generally serving as Army Chief of Staff. Moreover, the dispatch of political officers helped insure ideological indoctrination.<sup>17</sup> China was also a fertile ground for Soviet military advisors.<sup>18</sup> Ideological concerns also influenced the dispatch of military advisors to both sides in the Spanish Civil War.<sup>19</sup>

The ideological role of military advising intensified with the formal arrival of the Cold War and became the primary purpose of such work. As the US strode onto the world stage for the first time, it sought means to combat communist expansion without having to commit combat troops against the Soviets and their clients. Military advisors and military advisory and assistance missions became one of these tools. One of the earliest and most successful US military missions was that to Greece in 1946-7.<sup>20</sup> The most heavily studied of the US missions during this period is probably the Korean Military Advisory Group (KMAG). It began life helping combat a communist insurgency, but quickly went on to do other things. Bryan Gibby has recently completed a dissertation on the KMAG,<sup>21</sup> as well as a forthcoming article,<sup>22</sup> but it has also been the subject of many other studies.<sup>23</sup> Much US aid and assistance went to Chiang Kai-Shek and the Nationalist Chinese.<sup>24</sup> These three missions had in common the fact that they were intended to strengthen indigenous forces against internal and external communist threats.

The Soviets also invested heavily in foreign advising during the Cold War. Their mission to Cuba is probably the most famous of Soviet examples.<sup>25</sup> The Soviet mission in Egypt was also heavily involved in some key events of the twentieth century.<sup>26</sup> There is some readily available material on Soviet missions,<sup>27</sup> even reports from participants,<sup>28</sup> but this is a field wide-open for exploitation.

### **Countering Insurgencies: A New Role for Military Advisory Missions**

With the onset of the Cold War, one of the primary tasks of US advisory missions became conducting counterinsurgency operations or training other nations to do so. Nation building often went hand in hand with this task. There is an abundance of literature on US missions during this period, and even an early, brief history of the US efforts in Greece, Iran, the Philippines, China, Korea, and a few other places.<sup>29</sup> Famously, the US sent an enormous military advisory group to South Vietnam.<sup>30</sup> An under-examined element is the US effort to advise the South Vietnamese Air Force, but Ed Westermann has recently made an effort to fill some of this gap.<sup>31</sup>

Less well known is the British mission to Vietnam, which advised the South Vietnamese government in the early 1960s, concurrent with the US mission. The presence of two missions, often advising on the same topic, was sometimes a problem. Their views clashed on at least one occasion and the British team circumvented their American counterparts to get a plan for combating the North Vietnamese-backed communist insurgency into the hands of South Vietnamese leaders. These multiple missions, though sometimes helpful, also were the sources of multiple streams of advice and multiple anti-insurgency operations. Sometimes this produced operations not supportive of one another, as well as the dissipation of resources.<sup>32</sup>

Latin America also became an important arena for US military advising with the onset of the Cold War. Many of the members of various US teams there have left accounts of their service.<sup>33</sup> John Waghelstein, a former head of the El Salvador mission, has written extensively about his experiences there, as well as the many other places he worked as a military advisor during his long Army career.<sup>34</sup> Counter-narcotics operations have sometimes been tied to military advisory groups doing counterinsurgency operations. The US military mission in Columbia is the best known of such missions. Douglas Porch is currently preparing a study of this.<sup>35</sup>

## **The Corporatization of Military Advice: Military Advising for Fun and Profit**

Mercenaries went out of fashion after World War I, but they never disappeared. Soldiers of Fortune experienced a renaissance in demand for their skills during the Cold War, particularly in Africa.<sup>36</sup>

With the end of the Cold War, a new form of military advising moved to the forefront: the private corporate approach. Private Military Companies (PMCs) began taking on the role of training the military forces of often newly independent states. Croatia provides a good early example of this.<sup>37</sup> But the most important current example is in Iraq, where innumerable private companies have taken on security tasks, as well as the training of Iraqi troops. Christopher Spearin has done an excellent job of shining some light on their various roles as the trainers of military and police forces, and showing that while sometimes private corporations are the solution, sometimes they are also the problem.<sup>38</sup> The most famous work on PMCs is *Corporate Warriors* by P.W. Singer.<sup>39</sup> But also readily available is the book by Deborah Avant, *The Market for Force*.<sup>40</sup> Public Broadcasting's *Frontline* news program has also aired a one hour program on security contractors in Iraq.<sup>41</sup> There is also a useful website devoted to PMCs that details some of the available literature.<sup>42</sup>

## **The Military Advisor: The Agent of Change (Sometimes)**

Another facet of military advising ripe for study is the personnel themselves. Who are they? How does their experience affect them? What are the lessons they learn? This is a little examined field but there is at least one anthropologist, Anna Simons, looking at military advisors and writing about them.<sup>43</sup> The US government has also tried to define exactly what, or who, a military advisor is.<sup>44</sup> There are also a number of works examining the obstacles military advisors face<sup>45</sup> and that offer 'lessons learned' and general advice,<sup>46</sup> as well as help in dealing with unfamiliar cultures.<sup>47</sup> Brigadier General Daniel P. Bolger has recently added to this literature, giving guidance specific to US advisors serving in Iraq.<sup>48</sup>

## **Military Advising Today: All of the Above and A Little Bit More**

Even though corporations have taken on some of the advising tasks, they are still not the primary movers and shakers in the military advising business. This remains the United States, which is carrying on a number of military advisory missions.<sup>49</sup> The one most often in the news is that in Iraq, about which much has already been written<sup>50</sup> and much more is in preparation. The US is being supported by a number of other nations, particularly Great Britain, which is training the new



Iraqi Navy.<sup>51</sup> Iraq is also the beneficiary of a NATO training mission, which began training Iraqi officers on 24 August 2004.<sup>52</sup>

Afghanistan is undoubtedly the second most important arena for US advising. This mission also demonstrates one of the new developments in advising: the multi-national mission. For example, teams training the new Afghan armored units, though led by Americans, work with personnel from the Romanian and German armies.<sup>53</sup>

Multi-national missions dedicated to nation building are becoming one of the standard means of providing military assistance. As military forces continue to shrink, nations capable of developmental advising have fewer assets available for this task. Multi-national missions spread the costs, risks, and burdens of advising. On 31 March 2002, the European Union embarked upon its first military advisory mission, Operation Concordia, in Macedonia. This was done by assuming command of the NATO Peacekeeping Mission there since August 2001, which had been transformed into a smaller advisory and training mission on 16 December 2002.<sup>54</sup> The most multi-national of all military missions must be the International Security Assistance Force (ISAF). This British-led group was established in January 2002 to help rebuild Afghanistan. The initial plan was for it to have personnel from eighteen nations.<sup>55</sup>

There is also what might best be termed a quasi-military approach, meaning that advisory or assistance teams composed of civilian and military experts, all employed by or in the service of the US government, help a nation reform or modernize its military structures. In the post-Cold War environment, this has been one of the means by which new nations are prepared for membership in NATO. The rebirth and development of an independent Estonian defense structure provides a good example of this.<sup>56</sup>

### **Some Conclusions**

Military advising is here to stay. Nations will continue to want foreign military advice to modernize their own military forces, or combat an enemy. Nations will continue to offer such advice to further their own political and economic objectives. And private providers of military expertise will continue to offer their services to virtually anyone from whom they can profit. Fortunately, the field is also acquiring new students of the art who are approaching it from a broad and comparative perspective,<sup>57</sup> but it is a field with abundant gaps sorely in need of a coherent history and deeper analysis.

## Endnotes

1 States importing military ideas for their own purposes is the unifying idea of David B. Ralston, *Importing the European Army: The Introduction of Military Techniques and Institutions into the Extra-European World, 1600-1914* (Chicago and London: University of Chicago Press, 1990).

2 Donald Stoker, *Britain, France, and the Naval Arms Trade in the Baltic, 1919-1939: Grand Strategy and Failure* (London: Frank Cass, 2003), 102-19.

3 Some of the more famous examples of individual advisors include T.E. Lawrence, and John Paul Vann. For their stories see, respectively, T.E. Lawrence, *Seven Pillars of Wisdom: A Triumph* (New York: Anchor Books, Doubleday, 1991); Neil Sheehan, *John Paul Vann and America in Vietnam* (New York: Random House, 1988). Also useful, and famous, is T.E. Lawrence's '27 Articles,' *The Arab Bulletin* (20 August 1917). It can be accessed on the web at: [www.lib.byu.edu/~rdh/wwi/1917/27arts.html](http://www.lib.byu.edu/~rdh/wwi/1917/27arts.html).

4 John P. Dunn, *Khedive Ismail's Army* (London: Routledge, 2005).

5 John P. Dunn, 'Americans in the Nineteenth Century Egyptian Army: A Selected Bibliography,' *The Journal of Military History*, Vol. 70 (Jan. 2006): 123-36.

6 Frederick J. Cox, 'The American Naval Mission in Egypt,' *The Journal of Modern History*, Vol. 26, No. 2 (June 1954): 173-8; Frederick J. Cox, 'Colonel John Lay's Naval Mission in Egypt,' *Cahier d'histoire egyptienne*, Vol. 5 (1953): 36-46.

7 William F. Sater, 'The Impact of Foreign Advisors on Chile's Armed Forces, 1810-2005,' in Donald Stoker, ed., *Military Advisors and Missions, 1815-2005: From Mercenaries to Privatization* (London: Routledge, 2007).

8 Caleb Carr, *The Devil Soldier: The American Soldier of Fortune Who Became a God in China* (New York: Random House, 1992).

9 John P. Fox, 'Max Bauer: Chiang Kai-Shek's First German Military Adviser,' *Journal of Contemporary History*, Vol. 5, No. 4 (1970): 21-44.

10 Billie K. Walsh, 'The German Military Mission in China, 1928-38,' *The Journal of Modern History*, Vol. 46, No. 3 (Sept. 1974): 502-13.

11 For information on an early advisor to the Chinese Communists see Frederick S. Litten, 'Otto Braun's Curriculum Vitae – Translation and Commentary,' *Twentieth-Century China*, 23.1 (Nov. 1991): 31-62. Interestingly, both the Chinese Nationalists and Communists had German advisors.

12 Ernst L. Preisseisen, *Before Aggression: Europeans Prepare the Japanese Army*, The Association for Asian Studies: Monographs and Papers, No. XXI (Tucson, AZ: The University of Arizona Press, 1965).

13 Chris B. Rooney, 'The International Significance of British Naval Missions to the Ottoman Empire, 1908-1914,' *Middle Eastern Studies*, Vol. 34, No. 1 (Jan. 1998): 1-29.

14 Stoker, *Britain, France, and the Naval Arms Trade in the Baltic*, 141-64; Björn Forsén and Annette Forsén, 'German Secret Submarine Exports, 1919-35,' in Donald J. Stoker and Jonathan A. Grant (eds.), *Girding for Battle: The Arms Trade in a Global Perspective, 1815-1940* (Westport, CT: Praeger, 2003), 113-34.

15 As an example see William F. Sater, 'The Impact of Foreign Advisors on Chile's Armed Forces, 1810-2005,' in Stoker, ed., *Military Advisors and Missions*.

16 Suzanne Champonnois, 'Colonel Emmanuel du Parquet's Mission in Latvia, 1919-

- 1920,' *The Journal of Baltic Studies*, Vol. XXIII, No. 4 (Winter 1992): 325-40; Stoker, *Britain, France, and the Naval Arms Trade in the Baltic*, passim.
- 17 Ilya I. Kuznetsov, 'The Soviet Military Advisors in Mongolia, 1921-39,' *The Journal of Slavic Military Studies*, Vol. 12, No. 4 (Dec. 1990): 118-37, especially 119-22, 124, 126.
- 18 Litten, 'Otto Braun's Curriculum Vitae,' 31-62; Alexander Ivanovich Cherepanov, *Notes of a Military Advisor in China*, Alexandra O. Smith, trans., Harry H. Collier and Thomas M. Williamsen (eds.), (Taipei, Taiwan: Office of Military History, 1970).
- 19 John Daley, 'Soviet and German Advisors Put Doctrine to the Test: Tanks in the Siege of Madrid,' *Armor* (May-June 1999): 33-7.
- 20 Edwin P. Curtin, 'American Advisory Group Aids Greece in War on Guerrillas,' *Armored Cavalry Journal*, Vol. 58, no. 1 (Jan.-Feb. 1949): 8-11, 34-5.
- 21 Bryan Gibby, 'Fighting in a Korean War: The American Military Missions to South Korea, 1946-53,' Ph.D. Dissertation, Ohio State University, 1995.
- 22 Bryan Gibby, 'American Advisors to the Republic of Korea, 1946-1950,' in Stoker, ed., *Military Advisors and Missions*.
- 23 Alfred Hausrath, *The KMAG Advisor (U): Role and Problems of the Military Advisor in Developing an Indigenous Army for Combat Operations in Korea* (Chevy Chase, MD: Operations Research Office, Johns Hopkins University, 1957); Allan R. Millett, 'Captain James H. Hausman and the Formation of the Korean Army, 1945-1950,' *Armed Forces and Society*, Vol. 23, No. 4 (Summer 1997): 503-39; Peter Clemens, 'Captain James Hausman, US Military Advisor to Korea, 1946-48: The Intelligent Man on the Spot,' *The Journal of Strategic Studies*, Vol. 25, No. 1 (Mar. 2002): 163-98.
- 24 Ernest R. May, *The Truman Administration and China, 1945-1949* (Philadelphia, New York, and Toronto: J.B. Lippincott Company, 1975).
- 25 Richard Woff, 'The Soviet-Cuban Military Alliance: The Role of the Soviet Military Adviser, 1961-1986,' *Soviet Command Changes and Policy Implications*, Rapid Report No. 30, College Station, TX: Defense Studies/Center for Strategic Technology, Oct. 1986.
- 26 E.V. Badolato, 'A Clash of Cultures: The Expulsion of Soviet Military Advisors from Egypt,' *Naval War College Review*, (March-April 1984): 69-81.
- 27 William H. Mott IV, *Soviet Military Assistance: An Empirical Perspective*, Contributions in Military Studies, No. 207 (Westport, CT: Greenwood Press, 2001).
- 28 Cherepanov, *Notes of a Military Advisor in China*.
- 29 Walter G. Hermes, *Surveys of the Development of the Role of the US Army Military Advisor*, Department of the Army, OCMH Study, 1966.
- 30 G.C. Hickey and W.P. Davison, 'The American Military Advisor and His Foreign Counterpart: The Case of Vietnam,' Santa Monica, CA: Rand Corporation, 1965; Ronald H. Spector, *Advice and Support: The Early Years, 1941-1960, United States Army in Vietnam*, Washington, DC: Center of Military History, 1983; Robert F. Futrell, *The Advisory Years to 1965, The United States Air Force in Southeast Asia*, Washington, DC: Office of Air Force History, 1981; Edward J. Marolda and Oscar P. Fitzgerald, *From Military Assistance to Combat, 1959-1965: The United States Navy and the Vietnam Conflict* (Washington, DC: Naval Historical Center, 1986; Jeffrey J. Clarke, *Advice and Support: The Final Years, 1965-1973, The United States Army in Vietnam* Center of Military History Publication No. 91-3, Washington, DC: USGPO, 1998.

31 Edward B. Westermann, 'Fighting with the South Vietnamese: Farm Gate and the American Air Advisory Mission in Vietnam, 1961-1963,' in Stoker, ed., *Military Advisors and Missions*.

32 Peter Busch, 'Killing the 'Vietcong': The British Advisory Mission and the Strategic Hamlet Programme,' *The Journal of Strategic Studies*, Vol. 25, No. 1 (Mar. 2002): 135-62. See especially pages 140-1, 146-7. This excellent article makes fine use of former East German archival material.

33 Some examples: John E. Hall, 'My Experiences as an Advisor in El Salvador,' Carlisle Barracks, PA: US Army War College, 1999; Marcos R. Mendez, 'The Role of an MI Advisor in El Salvador,' *Military Intelligence Professional Bulletin*, Vol. 19, No. 4 (Oct.-Dec. 1993): 28-31.

34 John D. Waghelstein, 'Ruminations of a Woolly Mammoth: Adventures in Military Advising,' in Stoker, ed., *Military Advisors and Missions*.

35 Douglas Porch, 'The US Military Advising Mission in Columbia,' in Stoker, ed., *Military Advisors and Missions*.

36 See an account by one of the most famous mercenaries: Mike Hoare, *Mercenary* (New York: Bantam Books, 1979). Also available at any local bookstore is *Soldier of Fortune* magazine.

37 <http://www.abc.net.au/rn/talks/bbing/stories/s10592.htm>. See also [www.mpri.com](http://www.mpri.com).

38 Christopher Spearin, 'A Justified Heaping of the Blame? An Assessment of Privately Supplied Security Sector Training and Reform in Iraq – 2003-2005 and Beyond,' in Stoker, ed., *Military Advisors and Missions*.

39 P.W. Singer, *Corporate Warriors: The Rise of the Privatized Military Industry* (Ithaca and London: Cornell University Press, 2003).

40 Deborah D. Avant, *The Market for Force: The Consequences of Privatizing Security* (Cambridge: Cambridge University Press, 2005).

41 Marcela Gaviria and Martin Smith, Producers, 'Private Warriors,' *Frontline*, Transcript available at: <https://www.pbs.org/wgbh/pages/frontline/shows/warriors/etc/script/html>.

42 [www.privatemilitary.org](http://www.privatemilitary.org).

43 Anna Simons, 'The Military Advisor as Warrior-King and Other "Going Native" Temptations,' in Pamela R. Freese and Margaret C. Harrell (eds.), *Anthropology of the United States Military: Coming of Age in the Twenty-First Century* (New York: Palgrave Macmillan, 2003), 113-33.

44 Dean K. Froehlich, 'The Military Advisor as Defined by Counterparts,' Human Resources Research Organization, Mar. 1970.

45 William H. Riley, Jr., 'Challenges of a Military Advisor,' *Military Review* (Nov. 1988): 34-42.

46 Melchor Becena, 'Advising Host-Nation Forces: A Critical Art,' *Special Warfare* (May 1993): 26-8; Paul Marks, 'Advisers and Advising in the 21<sup>st</sup> Century,' *Special Warfare* (Spring 2001): 28-37.

47 George M. Guthrie, 'Conflicts of Culture and the Military Advisor,' Institute for Defense Analyses, Nov. 1966.

48 Daniel P. Bolger, 'So You Want to Be an Adviser,' *Military Review* (Mar.-Apr. 2006), 2-8.

49 Recent information on some of these can be found in Robert D. Kaplan, *Imperial Grunts: The American Military on the Ground Today* (New York: Random House, 2005). See also James Brandon, 'To Fight Al Qaeda, US Troops in Africa Build Schools Instead,' *Christian Science Monitor*, 01/09/2006, <http://www.csmonitor.com/2006/0109/p01s04-woaf.html>; Jason Motlagh, 'US Takes War on Terror into Sahara,' *The Scotsman*, 14 Dec. 2005, <http://www.thescotsman.scotsman.com/print.cfm?id=id2403492005>.

50 Dwayne Aaron and Cherilyn A. Walley, 'ODA 542: Working with the Free Iraqi Fighters,' *Veritas: Journal of Army Special Operations History*, Vol. 31 (Winter 2005): 86-8; Gary Skubal, 'An Iraqi Answer for Terrorists: A Day with the Commandos in Tal-lafar,' 14 Oct. 2005, [http://realclearpolitics.com/Commentary/com-10\\_012\\_GS\\_pf.html](http://realclearpolitics.com/Commentary/com-10_012_GS_pf.html); Robert H. Scales, 'The Emerging Iraqi Army,' 14 Oct. 2005, <http://www.washtimes.com/functions/print.php?StoryID+20051013-084116-5500r>; James Fallows, 'Why Iraq Has No Army,' *The Atlantic*, Vol. 296, No. 4 (Dec. 2005): 60-88; Anthony H. Cordesman, with Patrick Baetjer, *Iraqi Security Forces: A Strategy for Success* (Westport, CT: Praeger, 2005).

51 Thomas L. Friedman, 'Rebuilding Iraqi navy means changing culture of fear,' *The Houston Chronicle*, 29 Sept. 2005, <http://www.chron.com/cs/CDA/ssistory.mpl/editorial/outlook/3376043>.

52 Rick Lynch and Phillip D. Janzen, 'NATO Training Mission – Iraq: Looking to the Future,' *Joint Forces Quarterly*, No. 40, 1<sup>st</sup> Quarter (2006): 29-34.

53 Jon Byrom, 'Training the New Afghan Armored Forces,' in Stoker, ed., *Military Advisors and Missions*.

54 <http://www.europeansecurity.net/espdpdptimeline2000.html>, 2/2/2006.

55 <http://www.europeansecurity.net/espdpdptimeline2000.html>, 2/2/2006. These nations were: Austria, Denmark, Belgium, Bulgaria, Finland, France, Germany, Great Britain, Greece, Italy, the Netherlands, New Zealand, Norway, Portugal, Romania, Spain, Sweden, and Turkey.

56 Thomas-Durell Young, 'Approaching the Need for Defense Reform: Early Lessons Learned in Estonia,' *The DISAM Journal* (Winter 2003-4), 71-5.

57 William H. Mott IV, *Military Assistance: An Operational Perspective*, Contributions in Military Studies, No. 170 (Westport, CT: Greenwood Press, 1999).



## **Twenty Years of Army Overseas Security Assistance**

### **Mr. Kenneth Haynes—The United States Army Security Assistance Training Management Organization (SATMO)**

#### **Executive summary**

In this article, the organization's Executive Director describes the role SATMO plays in executing Security Cooperation and Security Assistance (SC/SA) goals. This small Army outfit satisfies specific foreign policy requirements by deploying Army training and technical assistance teams overseas. The author describes SATMO's role as an instrument of SC/SA as it has evolved, and as it continues evolving since 9-11. Data chronicling twenty years of SATMO activities illustrate this role.

#### **Purpose**

This paper introduces SATMO, the United States Army Security Assistance Training Management Organization, describing it as a successful agent of United States foreign policy. It orients you to SATMO's position in policy matters and the organization of our government, and describes the skills and activities that make SATMO uniquely valuable and suitable for its purpose. It shows the value of the organization to the emerging requirements of coalition warfare and describes patterns of success that recommend SATMO's permanent role in Security Cooperation and Security Assistance (SC/SA). Finally, attachments to the paper provide historians with key facts chronicling twenty years of SATMO operations overseas.

#### **A Short History of SATMO**

SATMO began as the United States Army Institute for Military Assistance (USAIMA) at Fort Bragg. This agency sent teams overseas for training and technical assistance tasks relating to the Special Forces' Foreign Internal Defense mission. Through a maturation process, the Special Forces nature of the work diminished as more and more missions involved the other branches of the Army. That is, not all of the teams were helping one or the other side of an insurrection. In 1974, the agency became SATMO, a TRADOC entity, and TRADOC took charge of Army OCONUS Security Assistance training.

## **Purpose and Goals of Security Assistance**

The terms “Security Cooperation” and “Security Assistance” overlap somewhat with the more recognizable term “foreign military aid.” Security Cooperation (SC) is a broader term than Security Assistance. The activities of SC focus on building relationships that promote specified US interests. For example, SC seeks to build allied and friendly nation capabilities for self-defense and coalition operations and to provide US forces with peacetime and contingency access to allies.

Security Assistance (SA) is a subset of Security Cooperation whose activities aim specifically at our allies. SA seeks to promote our allies’ self-sufficiency, encourage the training of their future leaders, support enhanced relations between the United States and foreign countries, expand foreign understanding of the United States and its culture and values, and to participate in international narcotics control.

Of course, for the layman, we describe Security Assistance as foreign military aid. The activities of SC/SA constitute a tool of foreign policy that is neither a blunt nor single-purpose instrument. The activities can be free, loaned or purchased. They can be from any of our military services, and can take many forms. The unifying theme is that the United States extends military aid to an ally. A broad purpose statement may be that “the activities of security assistance promote US national interests by improving the military capabilities of our allies.” Without specifying the broader purposes behind the governing foreign policy, the statement simply manifests the subordination of SC/SA to foreign policy, and designates the status of SC/SA as a tool of the higher level purposes.

## **Policy Environment**

Clearly the purposes and goals of SC/SA exist to support policy. In the case of SC/SA, every executive agency reacts to policy above it, based on its skill sets. The following simplified diagram shows this skill differentiation as it relates to SATMO.

Working from the top down, the “Strategic Plan” of the Department of State (DOS) covers a broad spectrum of foreign policy requirements. Agencies within the DOS can execute many of those requirements, as can other government agencies. However, only the Department of Defense (DOD) has the intrinsic skills to execute the military aspects of foreign policy. For DOD, the security assistance part of the military function has not been a core competency or principal mission. That is, prosecuting US interests through the use of military force has always been DOD’s *raison d’être*, while helping other militaries to develop was not. In order



to execute this function, DOD has a specialized policy body, the Defense Security Cooperation Agency (DSCA). DSCA selects out of the Strategic Plan those functions that the military must perform and publishes it as the Secretary of Defense Security Cooperation Guidance, promulgating it to the services and to the geographically oriented unified combatant commands (COCOMs).

The Army prepares for and conducts ground warfare as its principal function. Helping allies' armies is secondary, but the DOD guidance makes SC/SA a real mission. The Army G3 parses the guidance against its core competencies, and publishes the Army International Activities Plan.

The COCOMs (CENTCOM, EUCOM, PACOM, SOUTHCOM), which each have elements of all the uniformed services, also publish Theater Security Cooperation Guidance (TSCG) based on the DOD guidance, and matched to region-specific requirements.

The left side of the diagram omits the plans created by the various agencies of the Department of State and concentrates on the embassies. Each embassy publishes a country-specific Mission Performance Plan (MPP) based on the overall Strategic Plan.

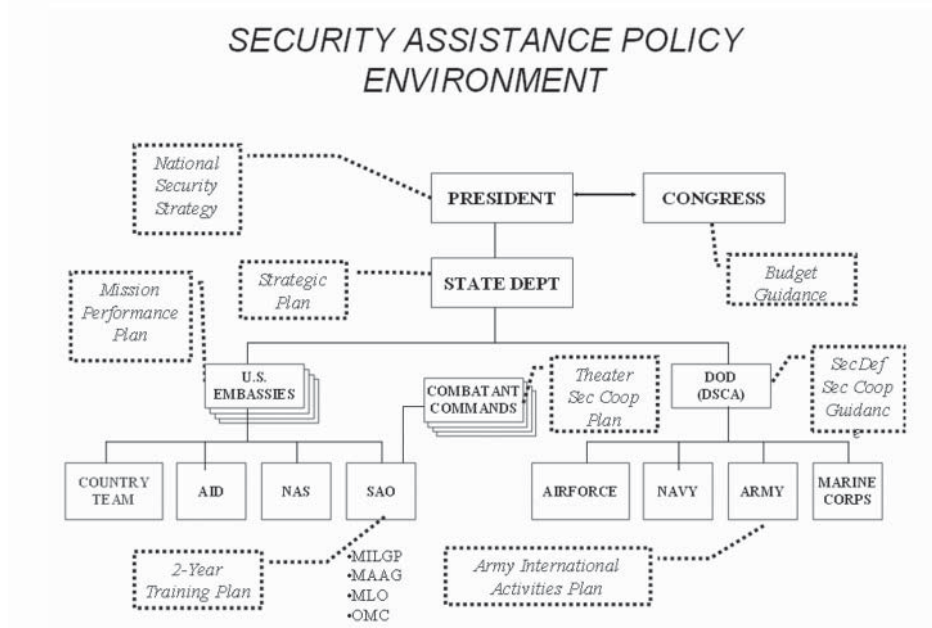

The embassies are in charge of the execution of US foreign policy in each country, through the country team. One member of the country team is a military officer generically called the Security Assistance Officer (SAO), a title that is now changing to Security Cooperation Officer. This officer can be from any service. As the diagram shows, SC/SA policy guidance converges on the SAO. The SAO works for both the COCOM Commander (who rates him) and the ambassador. The SAO must execute his assigned country's part not only of the ambassador's MPP, but also the COCOM's TSCG. For SATMO purposes, the document that describes this converged policy is the SAO's 2-Year Combined Education and Training Program Plan. Of course, the SAO's plan also satisfies the host nation.

No other activity on the diagram shares this "convergence." For this reason, any US agency that conducts SC/SA activities in a foreign country ought to treat the SAO as its center of gravity or customer. That is the case for SATMO.

### SATMO's Policy Role

SATMO performs cradle-to-grave management of CONUS-Based OCONUS Security Assistance Teams that deploy to our allies on training and technical assistance missions. SATMO's charter has been, from the beginning, the prosecution of US foreign policy. Specifically, SATMO performs at the bottom of a pyramid of binary choices about how agencies operationalize foreign policy. It looks like this:

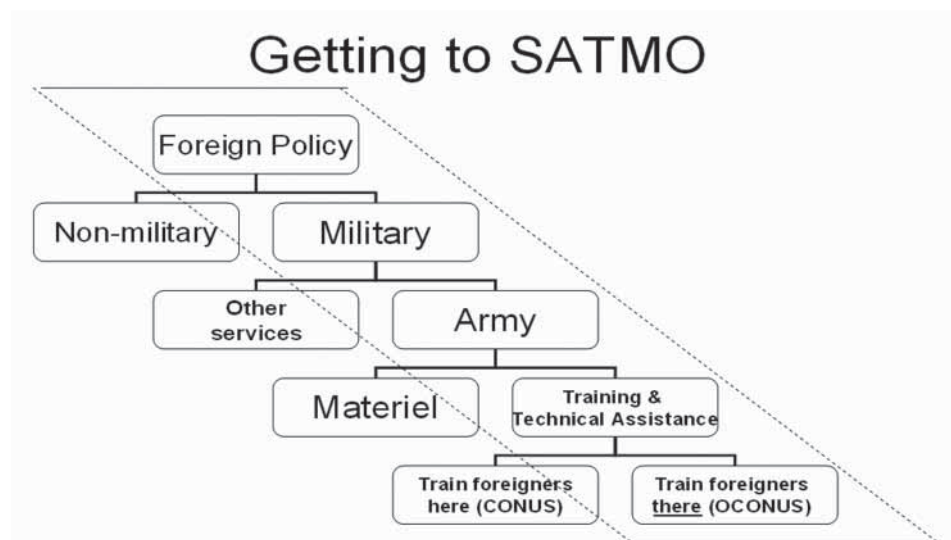

Reading from top to bottom, the diagram zeroes in on SATMO's mission. Foreign policy includes things that the military can do, as well as things that other agencies can do. The Army can do some of it, or another service might have to do it. The Army can provide materiel or people. The people can operate here or overseas. Still, the diagram is too simple because there are other Army-related training and technical assistance activities that don't involve SATMO. Personnel Exchange Programs (PEPs), intra-theater training teams, and National Guard partnerships all involve US military personnel training or assisting allies overseas in support of US policy, as does the Army's Request for Forces (RFF) process.

The actual agencies (not all of them) appear below:

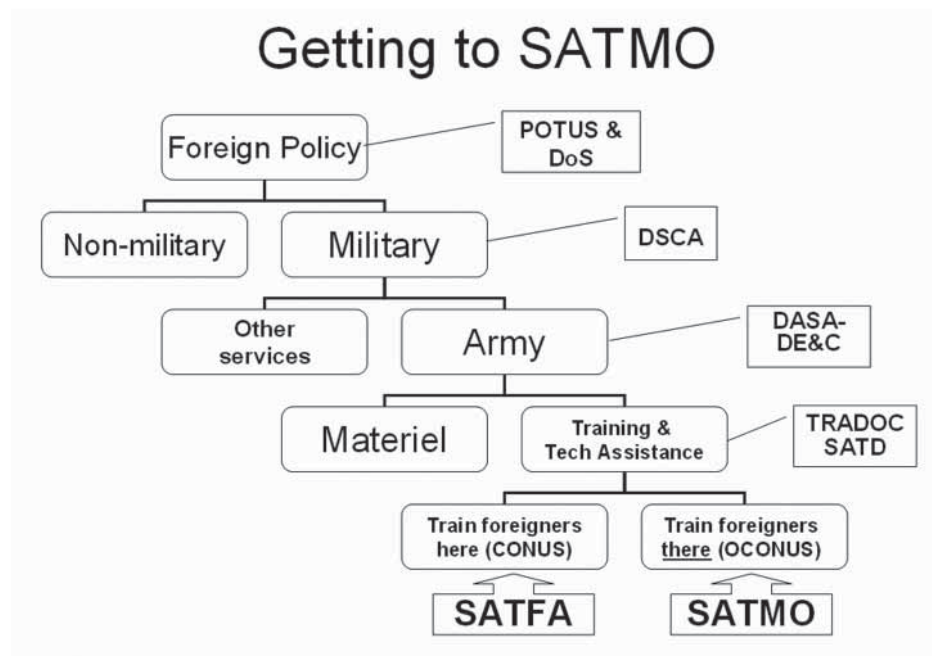

The diagrams purposely lean to one side to lead you to SATMO. In doing so, they leave out everything on the left side of the pyramid. Execution of US foreign policy is huge, and SATMO executes only a specific slice. If the government were an automobile manufacturer, SATMO would be the paint shop in one of the factories for one of the models. That is, SATMO is highly specialized.

Skill differentiation pervades the structure that these diagrams represent. The Army can support SC/SA in two major areas: materiel (weapons, systems, equipment) and cooperation (training and technical assistance). Army Materiel Command handles equipment, while Training and Doctrine Command (TRADOC) handles training. Neither helps our allies as a primary mission, so each has a specialized agency to do so. In HQ TRADOC, that agency is the Security Assistance Training Directorate, or SATD, handling both CONUS and OCONUS SC/SA training and technical assistance. TRADOC's Security Assistance Training Field Activity (SATFA) trains foreign military personnel on our soil, while SATMO trains them on their own soil.

### **Evolving Role Of The Military Vis-à-vis SC/SA**

**Coalition Warfare.** Since 9-11 and responding to the realities of the Global War On Terrorism, DOD has had to modify the idea that SC/SA activities are extraordinary, or not related closely to its purpose. That future wars will be fought with international partners as coalitions are now a more pressing reality. While the peacetime mission of DOD has always been to prepare for the next war, that preparation must now include preparing for coalition warfare. This requires that the skills and activities that were once “additional duties,” must become mainstream competencies and practices.

From the Army's standpoint, the activities that prepare allies to fight as “coalitions of the willing” include increasing future partners’:

- Willingness to fight with us, which includes:
  - Actual combat
  - Basing
  - Flyover rights
  - Transit
  - Use of their facilities and terrain
- Capacity, or their military strength in the coalition, which includes
  - Interoperability

We may abbreviate the purpose of these activities as access, influence and capacity.

### **Access, Influence and Capacity**

SATMO technical assistance and training give us great access to our allies and significant influence with them, while improving their capacity to fight with us, all in support of US foreign policy. (Materiel aid also provides these benefits, but in different ways and to a different extent.).

Arguably, the most important influence provided by SC/SA activities in support of coalition warfare is (and must be) the influence on the people that we will fight with. Influence serves to strengthen ties to our allies, enhancing the probability that the ally will willingly join us, and increasing the benefits the ally may provide us.

General PX Kelly once said that two services (Navy, Air Force) “man equipment,” while two services (Army, Marines) “equip men.” This distinction highlights the importance of the soldier-to-soldier aspect of training and technical assistance to the Army’s needs in coalition warfare. Training and technical assistance promote capacity and interoperability on the human side by helping our allies to operate equipment and systems and to learn and adopt successful doctrine, tactics, techniques and procedures. However, the human influence that accompanies training and technical assistance operates differently from gifts and loans of materiel.

Working together (the essence of Army training and technical assistance) creates successful partnerships as a part of the mission.

**One soldier helps another. They cooperate and jointly achieve objectives. They validate each other’s values and competence. Their mutual success engenders trust and confidence.**

Each training or technical assistance event is already a successful example of our access, influence and of the increased capacity of our ally.

### **SATMO’s Contribution to SC/SA**

What is the quantum of this benefit? The attached data set chronicles the last twenty years, in which almost eight thousand SATMO team members have logged almost two million man-days overseas, providing training and technical assistance to 134 allied countries.

Although these numbers cannot in the aggregate reflect the benefits that SATMO's brand of SC/SA provides or adequately describe the success of each team, the following assertions are empirically true. First, in the institutional memory of SATMO, which is over twenty years, no team has "failed." Without bias, the historian may look at each team deployment as a successful foreign policy event.

Second, the missions of each team have always involved leveraged influence. Allies choose overseas training when the number of their trainees is large because it is then more practical to take a few trainers to the country than to bring many trainees here. In almost all cases, each SATMO team member touches (influences) many foreigners.

Third, much of the teams' influence involves leaders and elites. That is, the SAO usually enjoys high status with his country's ministry of defense, and tries to position his team chiefs with important counterparts. At the recent Worldwide Team Chief's Conference, SATMO's current team chiefs diagrammed the influential contacts of their ongoing teams. The profound influence was instantly recognizable, with team chiefs enjoying and exploiting access to the highest levels of the military, and with examples of extraordinary influence. In all these cases, the influence was critical to the team's mission, and put US personnel in the position of directly helping the host nation personnel with a problem or mission of the country's choice. This is the pattern for all SATMO teams.

Fourth, each team's mission has always been tailored to foreign policy through a highly thorough process. The SAO calls teams forward from SATMO if and only if the mission meets the needs of the host nation, the COCOM, and the ambassador. In this sense, SATMO teams directly execute the refined and focused intent of US foreign policy.

Fifth, SATMO overseas training is, in itself, highly tailored. Foreign military personnel coming to the US for Army training will attend the same classes as US trainees, subject to disclosure and classification limitations, and on the same schedule. SATMO teams can modify programs of instruction or combine courses, training them on the ally's clock and tailoring each event to fit the local requirement and the local reality.

Sixth, SATMO teams help countries decide what to do with their militaries. A key type of team is the Requirement Survey Team (RST). RSTs visit the ally and help select the best materiel, technical assistance or training solution based on subject matter expertise and the country's current situation and desires. This

increases the appropriateness and effectiveness of every subsequent training event or materiel fielding.

Seventh, the regulations governing SATMO teams specify that personnel must be of the quality to represent the United States as soldier-ambassadors. That is, SATMO sends excellent representatives.

Eighth, SATMO rarely says “no.” SATMO can task the entire active Army, Reserves, National Guard and Government civilians. SATMO can call on Airmen, Sailors, Marines and even the Coast Guard. If the skills needed are not available, SATMO can contract for “graduates” (usually retirees) with the precise skills for each task. Even with today’s OPTEMPO, SATMO has no problems responding to the countries’ SAT requirements.

Last, SATMO trains or helps with almost anything relating to the Army, or to military activities not specific to a service. SATMO’s trainees range from General Officers to raw recruits. The teams’ titles cover every imaginable soldier skill, materiel system, doctrine, structure, tactic, technique or procedure. SATMO teams have trained ministers of defense and military police, radio operators and operations sergeants, special forces teams and counter-narcotics intelligence analysts, aircraft loaders and helicopter pilots, infantrymen and personnel specialists, purchasers and paymasters, tankers and artillerymen, commanders and staffs.

In summary, SATMO’s capabilities and history demonstrate its unique ability to support an important part of US foreign policy, even as that policy evolves in the post 9-11 era.





## **Cross-cultural Considerations for US Security Assistance in the Middle East**

**Major Hank Kron—US Army**

*“Now it is not good for the Christian’s health to hustle the Aryan brown.  
For the Christian riles and the Aryan smiles and he weareth the Christian down.  
And the end of the fight is a tombstone white with the name of the late deceased,  
And the epitaph drear: “A fool lies here who tried to hustle the East.”*

—RUDYARD KIPLING

The former Commander of US Central Command, General Tony Zinni provides a fascinating account of culturally based misunderstanding at senior levels in Tom Clancy’s book *“Battle Ready”*. General Zinni describes a situation where Secretary of Defense (SECDEF) William Cohen left senior meetings in the Arabian Gulf without any clue as to where his interlocutors stood. Secretary Cohen offered succinct explanations and crisp requests for endorsement of US military objectives in the region. Like most US officials, he expected to hear straight forward replies. Frustrated by hearing anything but responses to his agenda, General Zinni explains how he advised SECDEF that they actually had received endorsements of our objective in those meetings. Perplexed, Secretary Cohen said he did not hear any endorsements at all. However, the culturally astute General Zinni pointed out the subtle meaning of a parting phrase offered to Secretary Cohen: *“you must always know that we’re your friends”*<sup>1</sup>. Vagueness had been used to deliberately avoid a clearly defined position, which would have contained uncomfortable criticism. The operative implication was a positive reinforcement of the strategic relationship – thereby a “green light” without saying exactly so. Another example of the typical indirectness in the Middle East, but what was really meant was not readily understood - even by SECDEF...

Despite the fact that English was the common language, cultural rather than linguistic interpretations defined the nature of the communication. From senior US government officials on down to the array of US forces deployed in the Arabian Gulf region implementing the entire spectrum of Security Assistance/Security Cooperation activities, Americans grapple with the significant impacts of cultural differences in the Middle East<sup>2</sup>. Typical examples of misunderstood communication in the Middle East are: the ever polite and positive responses to requests that really mean something else; the avoidance of straightforward blunt criticism, seemingly irrational delays that belie a lack of consensus among decision mak-

ers; the reluctance of detailed long-range planning, the inexplicable avoidance to commit to obvious requirements according to our needs assessments. These are a few examples of situations that frequently present themselves to Americans in the region. Despite our long and successful history of engagement in the region, many Americans continue to misunderstand the real meanings behind these foreign behaviors. The unique context of interpersonal communication in conducting Security Assistance/Security Cooperation activities presents opportunities for us to acquire improved skills in understanding the mentalities and meaning of our Middle Eastern partners. We need to constantly work to enhance our cross-cultural comprehension levels to more effectively interact with our foreign partners in the Middle East.

US Department of Defense professionals who engage with our Middle Eastern partners are generally well prepared to deal with the obvious cultural differences. US service members and particularly those involved in implementing Security Assistance/Security Cooperation activities in the Middle East receive effective “cultural awareness” training, but the scope and depth is primarily to avoid embarrassing social offenses. US Security Assistance/Security Cooperation implementers are sensitized to Islamic practices and traditional Middle East norms. The aim is to demonstrate our respect for fundamental values in the region so that we can establish credible relationships that support our mutual interests. American personnel in the region generally know about: inappropriate use of the left hand, are sensitive to avoid compromising situations among mixed genders, adjust well to the enhanced restrictions during Ramadan, and understand what’s going on when hearing the calls to prayer five times per day, etc.

However, as highlighted in the passage from Tom Clancy’s “Battle Ready”<sup>3</sup>, even the most senior US officials can thoroughly misread the true meanings conveyed to us – in English – by our Middle Eastern friends and allies. Oftentimes subtle cues and hints go unrecognized while Americans engage with Middle Easterners. This is generally due to misunderstandings of culturally based assumptions. Our Security Assistance/Security Cooperation personnel encounter many subtle and foreign forms of verbal and non-verbal communication that are misinterpreted and or unnoticed, resulting in lost opportunities to effectively engage. There are many types of situations where less than effective cross-cultural communication can directly and adversely affect expectations and impact the outcomes of security assistance activities. Moreover, in large part because of the intangible nature of this subject matter, well intended after action-reviews tend to overlook the impacts, the contributing causes, and the resulting lost opportunities. Cross-Cultural misunderstandings often contribute to misunderstood intentions, diluted explanations, altered perceptions, and in many instances significantly impact mutual expecta-

tions and outcomes. Moreover, cultural misunderstandings and the impacts they can generate frequently occur as unrecognized factors—primarily on the American side. Given the importance of Security Assistance/Security Cooperation in contributing toward our strategic objectives in the War on Terrorism, we need to exploit any and every opportunity to become more effective in understanding and engaging with our vital partners in the Middle East.

Once we've acknowledged that there are situations in the Middle East that present foreign and subtle forms of communication that we may misinterpret, we can then work to gain a deeper understanding and improve our "cross-cultural comprehension level". To better understand why, to more reliably predict when, and to more effectively manage expectations requires an in-depth look into the motivations that drive behavior and the communication patterns that tend to emerge which reinforce those motivations. We can then observe the differences in cross-cultural communication in the Middle East and more effectively define the real meanings conveyed in communication.

In working to improve our knowledge, skills and abilities to better understand the various nuanced meanings in Middle Eastern cultural contexts, we first need to become more attuned to what is meant, rather than just what is said. In learning to read the meanings, we first need to understand the basic motivations of the actions. Recognizing and appropriately interpreting the fundamental motivations which drive meanings depends on knowing about the core ethos of the culture. We'll address some of the key drivers of motivation and behaviors in the Middle East by "peeling back the onion" of religious imperatives, values, traditions, and attitudes. Then, we'll highlight pivotal behavior patterns that reinforce those values. We'll then use a series of cross-cultural dialogues to exhibit how Americans and Middle Easterners use different mentalities to approach the same topics of discussion. Progress toward improved cross-cultural communications requires factoring in new considerations while interpreting meaning in interpersonal engagements. And finally, we need to realize that it takes ongoing practice and experience to improve cross-cultural communication skills.

Cultural adjustment and gaining enhanced cross-cultural communication skills is a more elusive effort than we might initially consider. Effective cross-cultural engagement requires a focused and raised comprehension of foreign and nuanced communications, coupled with practical experience over time. Further, complicating matters, assessing effective cross-cultural communications is also a difficult effort. How was this particular "blend of circumstances" reached and "what could have been" are frustrating questions to address. Outcomes are more reliable measurements of effectiveness, but inter-personal relationships and cross-cultural

communications defies hard evidence of effectiveness. This contributes to less emphasis on the intangible aspects of inter-personal relationships despite our recognition of the importance of those dynamics. We know it's important to drink tea and engage in casual conversation, but it's a chore for most Americans and many do not realize the depth and breadth of meanings in the information exchanged while "shooting the breeze".

Confucius said " All people are the same, it's only their habits that are different." In a practical sense, cultural adjustment to different habits suggests adjustment not to culture but to behavior. Culture is an abstraction that can be appreciated intellectually, but behavior is the key manifestation of culture that we encounter, experience, and deal with<sup>4</sup>. Both verbal and non-verbal communication are important behaviors in comprehending the actual meaning conveyed in a given context. But really understanding the key dimensions of what's going on in a given situation by what is termed "reading between the lines" can be a vague, intangible, and uncertain effort – even within one's own operating environment - let alone in a foreign context. Trying to detect the real meaning of what's being communicated often relies on unfamiliar cue words and phrases, as well as all sorts of body language. Further complicating this effort, defining the true meaning of a message can also be hinged upon what is not said, or how intensely something is said, and when something is said in a given context.

Much of this cross-cultural misunderstanding is due to reliance on expectations based on social conditioning. The familiar term "ethnocentrism" points to universal tendencies for people to evaluate foreign behavior by the standard of one's own culture. We are conditioned from our social environment to expect and assume certain meanings in given situations. Our cultural upbringing provides us with a frame of reference that we unconsciously use to interpret situations. However, we recognize that foreign cultures produce, in some instances, vastly different habits and patterns of action to convey different meanings. The old proverb notwithstanding, we can put ourselves in someone else's shoes, but it's still our own feet we feel<sup>5</sup>. A useful way to identify and define the differences in Middle Eastern communication patterns is to also recognize American behavior patterns and the underlying American cultural basis for communicating and comprehending situations.<sup>6</sup>

American practitioners in the field can work to raise awareness of probable differences in meaning and over time understand the coded hints, the underlying, oblique, and indirect subtle meanings conveyed by Middle Easterners. However, we need to realize that there is no consistently applicable formula to discern meaning in every set of circumstances. There is no absolute explanation that can

be applied to every situation. Each situation includes participants with individual traits and each situation carries a unique context that defines what meaning and responses are appropriate for the people engaged.

The cross-cultural dialogues in following paragraphs will illustrate and contrast the Middle Eastern and American “mentality”. The idea here is to identify some key culturally based assumptions in the Middle East that drives different behavior. Cross-cultural dialogues are useful tools to highlight how different cultural conditioning affects interpersonal behaviors. The dialogues show that culture affects meaning and that once aware of the motivations and subtleties, we can work to improve our understanding of actual intentions, and reduce the pitfalls of false expectations. The explanations of the dialogues contain generalizations. Cultural generalizations may be accurate about wider groups, but would never be wholly true of particular individuals. Individuals encountered in the Middle East will display a broad range of characteristics that may or may not conform to any extent to the typical generalizations. In particular, military officials in the Middle East generally represent an elite progressive class within their society. Most of the military officials in the Middle East who are specially selected to interact with Americans have either already served overseas or possess experience interacting with foreigners. As such, they tend to have adjusted their own cross-cultural communication skills to better interact with Americans. Consequently, the Middle Eastern official’s ways of communicating with Americans will invariably be different than the garden variety merchant in the bazaar. Nonetheless, a lifetime of cultural conditioning will continue to have a compelling drive upon the motivations and expressions that Middle Eastern officials will exhibit.

There is an underlying ethos - a shared core of assumptions about people and the world that Middle Easterners will continue to experience and express. It’s these core culturally driven motivations and communication patterns that are key to understanding context and meaning. Highlighting the underlying Middle Eastern cultural ethos that motivates and determines behavior patterns provides us with a basis of explanation of the supporting behaviors.

#### **Core Middle Eastern Ethos:**

- At the end of the day, GOD, not detailed planning determines outcomes (fate)
- Avoid shame - preserve the collective honor (group identity)
- Obligations to always remain courteous, polite, respectful, and hospitable

- Requirements to protect the virtues of our women
- Preserve and enhance the stature of history/reputation—of family, clan, tribe, region, ethnicity, those like us [states are the newest link]

### **Supporting Behavior Patterns:**

- Exaggerated flattery is an expectation. Reduced quantities subtly signals criticism. Absence of any flattery – silence - is thunderously meaningful and devastating.
- Identity lies in membership of a social group. The group takes the credit, so the group gets the flattery, not the individual. Over doing individual flattery invites jealousies from others. Intentionally over-exaggerated flattery to an individual signals an intent to wish bad tidings upon them.
- Since my team (family, clan, tribe, neighborhood, region, sect, nation, country) is everything, respecting the heirarchy is vital, and inter-personal relationships are approached through cooperation, group support and preserving appearances. Embarrassing others openly, publicly, and directly by competition and slander is reserved for outsiders.
- Working the network. Raise and reduce stature - praise and criticize - via intermediaries and emissaries. Who is doing it (who they are in the hierarchy) signals how heavy the meaning is.
- Silence speaks volumes. The absence of what would otherwise be said can be thunderously meaningful. No comment - no joy - no shame.
- One always knows - knows how to do it, knows someone who can do it. Knowing things and knowing people demonstrates individual abilities and personal stature. Long diatribes about related topics can mean I really don't know about that subject, but look how much I do know about this – so you'll continue to respect me
- Smiles and hospitable offerings mean little substantively. Strangers and foreigners must receive more. Familiar faces can gauge their standing by how much they receive relative to previous instances and others.
- The interpersonal relationship matters. Friendship sows trust, respect, and

mutual obligations for support. Thus, the need to look each other straight in the eyes, smell one's breath and body odor, touch hands and arms - to connect viscerally. Middle Easterners have highly honed skills at reading and judging people.

- Middle Easterners carry the reputation of their entire group. So, who's selected to be there "who's who" signals "what's what". Someone with the reputation and clout needs to be there to have anything done. "Experts" with no clout means no importance. It's not unlike the axiom: "It's not what you know, but who you know..."

### **Conceptual Comparisons of American and Middle Eastern Cultural Attributes**

<b>American</b>	<b>Middle Eastern</b>
Action Oriented	Interaction Oriented
Goal Oriented	Being Oriented
Direct/Open	Indirect/Tactful
Disclosing	Face Saving
Optimistic	Fatalistic
Individual Orientation	Interdependent Orientation <sup>7</sup>
Symmetrical Relationships (age, status)	Complimentary Relationships (age/status)
Do One Thing At A Time	Juggle Many Things At Once
Concentrate on the Job	Distractions/ Interruptions OK
Stick to Deadlines/ Schedules	Time Commitments Are Objectives
Focused on the Job	Focused on the People
Reluctant to Borrow or Lend	Often and Easily Borrow/ Lend
Avoid Crossing Privacy Boundaries	Minimal Privacy Boundaries With Family/ Friends/Close Associates
Accustomed to Short Term Relationships	Tendency Toward Lifetime Relationships <sup>8</sup>

The following situation based dialogues are intended to illustrate typical cultural differences and how Americans and Middle Easterners can approach the same situation from entirely different viewpoints. For some readers, the subtle cues and meanings conveyed by the Middle Easterners will be evident and stark. However, we need to remind ourselves that what may seem obvious to comprehend in an academic environment can be easily misread or missed altogether while engaging in a foreign and distracting set of circumstances on the ground.

**Situation: “Just Trying to Help”–Versus–“I Need A Straight Shooter Who’ll Get It Done”**

Iron Mike: I saw the official in the customs office today.

Abdullah: Oh, good.

Iron Mike: He said you never spoke to him about releasing that US Foreign Military Sales (FMS) equipment.

Abdullah: I’m very sorry, sir.

Iron Mike: In fact, he said he’s never heard of you.

Abdullah: It’s possible, sir.

Iron Mike: But when I asked you if you knew him and if you could help, you said you could.

Abdullah: Oh, yes, sir.

Iron Mike: But it wasn’t true. You don’t know him and you didn’t even talk to him.

Abdullah: Excuse me sir, but I was only trying to help.

For Iron Mike, Abdullah is not only ineffective, but may be considered a liar! He said he knew the customs official and he could help. Abdullah did not know the customs official—therefore he lied. However in his world, Abdullah is obliged to give his boss a positive response—whether or not he can actually deliver. Another Arab would understand that Abdullah’s positive response should not be taken literally – that he actually knows the man in the customs office and is going to be able to do something. It’s understood that he’s willing to try to help either because it’s his job and his superior has tasked him, or in another similar situation because a friend has asked for help. Abdullah figures that he may know somebody that knows the customs official and somebody can have some pull. Abdullah will use his network of friends to help.! Abdullah also expects some time to get this networking done and if after some time, he can’t then he expects his boss to realize that he wasn’t able to do it and he should look for another alternative—without



direct confrontation. Instead, Iron Mike directly confronts Abdullah with the failure and even implies he's a liar. It's a measure of Abdullah's good manners that he maintains his composure and respectfulness. If other Arabs had been witness to Iron Mike's confrontation revealing Abdullah's deficiencies, the shame factor would have a serious impact on Abdullah. It would be no surprise to other Arabs in that case, if Abdullah gradually withdrew his efforts and found a polite reason to find employment elsewhere. Iron Mike would have no clue as to why he lost a good man.<sup>9</sup>

### **Situation: "A Bird In the Hand"–Versus–"One Well Done or Two Half Baked"**

Mohammed: Sir, would you like to see the two new offices we've completed?

Iron Mike: Offices? I thought we agreed to build one office and, if there were any funds left over at the end of the fiscal year, we would buy equipment for the one office.

Mohammed: Yes, but there was enough money to build two offices at once.

Iron Mike: But, is there any money left over to equip the offices?

Mohammed: Unfortunately, no, sir.

Iron Mike: Then we can't use them!

Mohammed: Not presently, but isn't it good? We used all the money!

Iron Mike thinks Mohammed is cooking up something on the side or is irresponsible with government funds, or just plain irrational. Mohammed's view is completely different yet just as rational and dutiful as Iron Mike's. Mohammed wouldn't think to rely on left over money to remain available to fund office equipment. It's better to use up all the money at once while you have it available and then request additional money for the necessary equipment to complete the overall effort. Now you have two offices and the funding source is under pressure to equip at least one if not two. All this is based on operating assumptions of predictability and reliability of the system, the government, and even in reality in general. Iron Mike trust his system and government, and as an American has grown up with principles like: "Make it happen," "where there's a will there's a way," "there's nothing we can't do... !" Government services are transparent, law abiding, and for the benefit of citizens regardless of who's involved. Mohammed has no such notions of accountability in government or predictability over outcomes in life. Fate determines everything and if you have it you use it or lose it.<sup>10</sup>

### **Situation: Feasibility–The Facts or the Man**

Iron Mike: I think we should examine the feasibility study for the proposed Ministry building.

Nasser: I agree, sir. Perhaps we can begin by discussing who the director of the project will be.

Iron Mike: That will have to be decided, of course. But first we have to see if the project is doable.

Nasser: Yes, sir, that's exactly my point.

Iron Mike wants to examine the substance of the new project for a Ministry building to see if it's executable. Nasser is also interested in determining if the project is doable, but not by examining the facts contained in the feasibility study. He will know if it's really going to happen based on who's put in charge of the project. If someone of influence and authority is put in charge, then it means the Ministry takes the project seriously. If a relatively minor official with no clout is selected to run the project – no matter how expert he may be - it's a good bet the project will never get off the ground regardless of how well engineered the plans are.<sup>11</sup>

### **Situation: A Very Persuasive Decision Brief**

Iron Mike: So, Hamad, how do you think the briefing was?

Hamad: Sir, Brigadier Ali was very impressed. Your presentation was clear, organized, and informative.

Iron Mike: Well we worked really hard to capture all the data – we focused on the relevant metrics.

Hamad: Yes, the briefing had a lot of information.

Iron Mike: Yes, but It's been awhile and no feedback or decision from Brigadier Ali.

Hamad: I think the Brigadier may have thought there was something missing, that you were not very involved or enthusiastic about the project.

Iron Mike: I don't know what else I could have done, the facts really speak for themselves in project.

For Iron Mike, the cold hard facts don't lie. You can't argue with the statistics. Stick to the numbers and we can't go wrong. Brigadier Ali appreciates facts too, but facts are not going to implement the project. This is Iron Mike's project

and Brigadier Ali is thinking he certainly has his information in order, he's made a persuasive case on the merits of the facts. But who is Iron Mike. We can trust facts on paper. Brigadier Ali wants a warm and fuzzy about Iron Mike - that he's committed to complete the project as outlined. In addition to the facts, Brigadier Ali wants to see something of Iron Mike – the man - in his briefing, but Iron Mike didn't come out from behind his numbers. Instead of embarrassing Iron Mike by openly discussing his rational, Brigadier Ali would prefer to choose silence as a signal that he's not convinced to give the project to Iron Mike. If Iron Mike pressed for an answer, a polite yet seemingly oblique reason would be given by Brigadier Ali's intermediaries that would further confound Iron Mike.<sup>12</sup>

### **Situation: The Plan is Under Study**

Iron Mike: Abdulsalam, what did you think of the new plan?

Abdulsalam: Seems very fine, but I'm still studying it, we need to be certain.

Iron Mike: Still studying it after three weeks? It's not that complicated!

Abdulsalam: There are one or two aspects that might be a problem.

Iron Mike: Oh, I know that, but we should put the plan into action and work the bugs out later.

Abdulsalam: Seriously?

Iron Mike: Abdulsalam, what did you think of the new plan?

Abdulsalam: Seems very fine, but I'm still studying it, we need to be certain.

Iron Mike is ready to adopt new concepts into action and make adjustments once implemented. Many other cultures are skeptical of new things, "There's nothing new under the sun." The presumption is what's worked is better than risking failure. When all the glitches are addressed in the plan, then Abdulsalam may be more inclined to initiate a trail run. Trial and error is not the preferred way to operate. Americans believe if you fall on your face, you get up. Many other cultures feel if you fall on your face, no one ever forgets the sight of you sprawled in the mud.<sup>13</sup>

### **Situation: Wait Here – Versus – I'll Do It Myself on the Way**

Iron Mike: Khalid, I was wondering if my vehicle was ready from the service shop down the street yet?

Khalid: Yes, sir. The shop called and your car is ready.

Iron Mike: Great. I'll go pick it up.

Khalid: Oh, no sir! I'll send a driver to pick it up and bring it here for you.

Iron Mike: No need to pull someone out of the office for that. It's on my way anyway.

Khalid: Please, sir. You wait here and drink some tea. I'll have the car here right away.

Iron Mike is unaware of the image and status he carries around in this environment. The image of the American officer in charge walking down the street to the garage to talk with the mechanics to get his own car signals to those in this environment that his office is in disarray, his drivers and assistants are absent, and he has no clout to do anything about it. Not only does this reflect badly on Iron Mike in the eyes of the locals, but all the locals working in his office would never live it down to others that they allowed such an indiscretion to happen.<sup>14</sup>

#### **Situation: Performance Evaluation – Constructive Criticism**

Iron Mike: Khalil, let's go over your semi-annual performance evaluation.

Khalil: Whatever you think, sir.

Iron Mike: As you know, you're performing well overall. There are just a few areas for improvement I'd like to discuss with you.

Khalil: I see.

Iron Mike: One is in writing, which isn't easy for you, is it?

Khalil: No, sir.

Iron Mike: And the other is in identifying training needs. Your staff could use more computer training.

Khalil: Yes.

Iron Mike: Anyway, it's all written here in the report. You can read it for yourself. Otherwise, no serious problems.

Khalil: I'm very sorry to disappoint you, sir.

The imperatives of honor and avoidance of shame means that criticism has to be handled very delicately in the Middle East. Oftentimes, a lack of overdone praise is sufficient to signal dissatisfaction. When unavoidable, criticism should be expressed with the utmost discretion and indirection. Iron Mike was actually pleased with Khalil's performance and said so – once, and closed with “otherwise

no problems.” An American would probably read that evaluation just for what Iron Mike meant. For Khalil, the brief understated praise coupled with a direct focus on spelling out the deficiencies meant his boss thought he’s performing badly. Khalil naturally assumes that Iron Mike will bend over backwards to be sensitive about Khalil’s sense of self image, honor, and reputation. If that was the best Iron Mike could do to praise him, if that represents the best face Iron Mike could put on the situation, then Khalil’s read was things are bad for him there. If Iron Mike had quickly slipped the critique into a majority of the time highlighting Khalil’s successes, then Khalil would have been able to stomach the criticism. Now, Iron Mike has no clue that Khalil’s morale is shot after that performance evaluation. That terribly insensitive session will be the main family topic of discussion for a long time in Kahlil’s house. It would be no surprise to another Arab if soon enough Khalil’s performance really drops off and he soon finds a new place to work. Khalil would offer a plausible and polite reason to find employment elsewhere yet would remain on the friendliest of terms. Iron Mike will still have no clue as to really why he lost such a good man.<sup>15</sup>

#### **Situation: She’s The Best Man For the Job**

Iron Mike: Khalid, Even though the host nation senior leadership pledged to fully support our investigation, ever since I sent in Lieutenant Jane to investigate the incident, the host nation support has declined. Are they stonewalling because of gender?

Khalid: Sir, There are several female forensic officers in the military here.

Iron Mike: Well, Lt. Jane is the very best forensic expert we have. That should have signaled our priority on this.

Khalid: I’m sure everyone recognizes her technical expertise.

Although Iron Mike perceives a passive-aggressive reaction to assigning Lieutenant Jane to the case, he can’t see any other reason than gender bias as the cause of host nation indifference to her. Iron Mike sent in the best expert he had to work the case. The host nation reaction doesn’t make sense. Khalid understands that the lack of enthusiasm by the host nation to pursue the case is because an unknown officer of very young age showed up on the scene without Iron Mike’s personal endorsement on the ground. Her expertise notwithstanding, her youth and lack of introduction by a trusted senior, signals a lack of priority in the eyes of the locals.

**Situation: The “*Inshallah*”**

Iron Mike: Mohammed, will you be here tomorrow to join us for dinner, and will you bring your friends too please?

Mohammed: Yes, - Inshallah!

Iron Mike: We’ll expect to see you and your friends here for dinner tomorrow at 1900.

Mohammed: Yes, Mike, Inshallah. Dinner with you and our friends. It will be our pleasure!

Iron Mike has heard of the real meaning of Inshallah – “if God wills it”, it really means not likely to happen. So, Iron Mike will now invite another group for dinner because he doesn’t expect Mohammed to show.

In Mohammed’s context, Inshallah must be added—as reinforcement of his personal commitments. He said yes—twice, and confirmed yes is for dinner—with friends. Although he will do everything he can to attend, it’s doubtful he would show up precisely at 1900 sharp. Iron Mike is probably in for a surprise when Mohammed shows at 2030 and Mike will have to awkwardly manage the situation as he had invited another competing group to the dinner. The meaning of “Inshallah” can range from a definite yes—as in a subordinate’s response to a direct order from a superior, an uncertain maybe, and even to a polite deflection signaling no. The local environment, the context of the circumstances, and the people involved will all determine the appropriate usage.

**Situation: Getting to Know You...**

Iron Mike: Hassan, now that we’ll be working together as counterparts, I wanted to let you know about my background. I’ve got B.S. and M.S degrees in engineering and have 18 years experience in the US Army Corps of Engineers. I’ve completed several major projects of the type we’re about to embark on together. How about you?

Hassan: Sir, my family is from a section of Baghdad that you would probably not be familiar with. My uncle Nasser speaks excellent English and would like to meet you. Shall I arrange to have my Uncle Nasser meet you?

Mike has no clue as to the meaning of Hassan’s seemingly off target response. Mike will probably drive on and see how Hassan performs, but why couldn’t Hassan just rattle off his credentials and experience and what does his family’s location and his uncle have to do with it anyway? On the other hand, Hassan considers

it very inappropriate to tout his own credentials directly to Mike. Hassan typically discusses his family's background and most Arabs would instantly understand his reputation by his family name and by his neighborhood...Hassan did realize that Mike wouldn't know his family's reputation by mentioning the city and neighborhood, so he then proceeded to set up a meeting for Mike with his uncle who would represent his family and act as an intermediary with Mike and openly brag about his nephew's impressive engineering credentials.

### **Situation: The Agenda**

Iron Mike: Khalifa, I see what you mean. That's a very important point. That's what we need to focus on but...

Khalifa: Sir, now if I could explain some of the details.

Iron Mike: I wish you had brought this to my attention earlier in the meeting.

Khalifa: Excuse me, sir?

Iron Mike: I mean, this is something we need to look at together very closely, but we've already extended our meeting.

Khalifa: Yes, of course, sir. But if you'll just bear with me a few moments.

Iron Mike: Let me ask my secretary to put you on my calendar for Friday.

Khalifa: Excuse me, sir?

Iron Mike: So we can continue then.

Khalifa: You want me to come back again on Friday?

Even though Iron Mike recognizes that they're getting somewhere, he's unwilling to further extend the meeting and prefers to keep things on track rather than upset the schedule. Schedules are man made, but once we have a schedule, for many of us A-Type hard chargers, it's the person not the schedule that has to do the accommodating. To do otherwise means being unorganized and undisciplined. Khalifa is operating off of another set of assumptions. The time and schedules are meant to be a flexible framework to organize the day's activities. What can a few more minutes of their time be worth compared to resolving the issue.<sup>16</sup>

The following excerpts highlight how complex cross-cultural interactions can be and how others assume Americans are conditioned to respond.

### **Knowledge and a Little Luck!**

Sometime in 1906 I was walking in the heat of the day through the Bazaars. As I passed an Arab Café, in no hostility to my straw hat but desiring to shine before his friends, a fellow called out in Arabic, “God curse your father, O Englishman.” I was young then and quicker tempered, and could not refrain from answering in his own language that “I would also curse your father if he were in a position to inform me which of his mother’s two and ninety admirers his father had been!” I heard footsteps behind me, and slightly picked up the pace, angry with myself for committing the sin Lord Cromer would not pardon – a row with the Egyptians. In a few seconds, I felt a hand on each arm. “My brother,” said the original humorist, “return and drink coffee and smoke with us. I did not think that your worship knew Arabic, still less the correct Arabic abuse, and we would benefit further by your important thoughts.”

—RONALD STORRS, “*Orientations*”<sup>17</sup>

### **Those Americans, They’ll Follow The Rules – Even When There’s No Good Reason To!**

Once we were out in a rural area in the middle of nowhere and saw an American come to a stop sign. Though he could see in both directions for miles and saw no traffic was coming, he still stopped!

—Turkish Exchange Student In “*There Is A Difference*”<sup>18</sup>

### **Profiling the Yanks**

MacDonald’s restaurants are probably a good reflection of the American character. They’re fast, efficient, they make money, and they’re clean. If they’re loud and crowded and if the food is wastefully wrapped, packaged, boxed, and bagged...let’s face it, that’s us Americans.

—ANDY ROONEY “*A Few Minutes With Andy Rooney*”<sup>19</sup>

Increasing effectiveness in cross-cultural communication involves becoming more attuned to what the real meaning is in a situation—what is meant versus what is said. We need to recognize our own American-centric assumptions and then deliberately adjust our interpretations to our acquired understandings of Middle Eastern motivations, cultural conditioning, assumptions, and supporting behaviors. The challenge is not only to become equipped to define the situation more appropriately—that is according to the locals’ viewpoint. We also need to increase



our perceptiveness to recognize the brief and subtle cues while engaging in the substance of the agenda, and invariably while functioning within a broader and distracting environment. Discerning the significance of various behavior patterns can be like acquiring a new language. When we listen to someone speak a foreign language we tend to only hear those words that seem familiar, and the rest is noise. Similarly, in observing foreign behavior—including English spoken in a foreigner context—we pick out those actions and the meaning of the spoken English and define what’s going on according to our own culturally based assumptions. All the rest, rich in meaning to everyone but us, is just random undifferentiated action and utterances. It’s the same when we come across a word we don’t understand while reading. We guess at the meaning from the context. Further complicating this challenge is the Middle Eastern style of omission of input, or the deliberate timing or intensity of the input—all which impart a significance that is altogether absent in American forms of communication. We also need to be aware that there is not only behavior that we misinterpret because there’s no corresponding cultural meaning in the American context, but there is behavior and speech in the Middle East that we don’t even pick up on at all. There is, quite literally, more to a foreign culture than meets the eye. While we can’t always trust what we see, our observations remain the primary gauge to learn about a foreign culture. We simply have to be aware that some of what we see may only be in the eyes of the beholder!<sup>20</sup>

In identifying Middle Eastern core cultural ethos, we gain an improved understanding of the common motivations of behavior. We can realize that Middle Eastern motives can be very different than American “mentalities”. People naturally assume that their interpretations of context and meaning are common everywhere. Therefore, it is a common tendency for Americans to draw upon their own distinct American frames of reference to define meaning in cross-cultural situations - and likewise for the inexperienced Middle Easterner. The list of key Middle Eastern values and the highlights of various behaviors that tend to emerge in support of those values provide a basis to examine the cross-cultural dialogues. Cross-cultural dialogues can be an effective tool to exhibit vastly different mentalities expressed in key yet nuanced and subtle communications. The explanations of the dialogues - from the viewpoints of the American and Middle Eastern participants - offer insights as a new frame of reference to define meaning in certain situations.

American service members conducting Security Assistance/Security Cooperation activities with Middle Easterners need to remain mindful that we’ve acquired our own cultural conditioning over the course of our formative years into adulthood. We need to recognize that like learning a foreign language in adulthood, we gain proficiency, but our newly gained knowledge, skills, and abilities to adjust to foreign contexts should be a continuous learning process. If approached as an on-

going effort to enhance our cross-cultural communication abilities, we can expect to increase our understandings of why, increase our ability to predict when, and thereby improve our management of important mutual expectations that emerge in the unique interactive and personally driven Security Assistance/Security Cooperation field activities.

### Endnotes

1 Tom Clancy, "Battle Ready with General Tony Zinni Ret.", (Putnam, New York, 2004), pp. 308-309.

2 In this discussion, the term Middle East is defined as those peoples whose mother tongue is Arabic, and/or societies with Islamic traditions as the predominant basis of cultural values. While ethnically and somewhat culturally different, the Turks, Iranians, and Afghans are also included in this category. So, this definition of Middle East can extend well into both the EUCOM and well as CENTCOM Areas Of Responsibility (AOR). For instance, in the CENTCOM AOR, the four countries that comprise the Central Asian States, despite their Turkic heritage and in the instance of Tajikistan - a Farsi lineage, have evolved into hybrid cultures combining the legacy of the Central Asian steppe tribes with recent Russian influences. The societies of the Indian subcontinent - what used to be comprehensively referred to as Hindustan - despite their robust Islamic identities, possess unique cultures that incorporate the South-West Asian culture with British traditions. Maronite and Coptic Christians in the Levant and "Misir" (Egypt) whose mother tongue is Arabic will tend to exhibit mostly the same culturally based communication patterns as their Muslim brethren. Likewise, Arabic speaking peoples across the Mahgreb and sub-Saharan Africa will also generally share the same culturally based communication patterns as peoples in the Arabian peninsula and Mesopotamia.

3 Ibid., pp. 308-309.

4 Craig Storti, "The Art of Crossing Cultures", (Yarmouth, Maine, 1989), p. 14.

5 Ibid, p. 51

6 We develop our notions of how to behave and interpret situations from our upbringing. We internalize these behaviors and meanings to the point where they become unconscious and instinctual. What we know and understand is what we've taken in and has been reinforced from our experiences. But the world we observe and the behaviors we internalize – are not exactly the same as Mohammed's. In the US parents teach their kids that it's good to be an individual, to be self reliant; that you should say what you mean and mean what you say; where there's a will, there's a way; that hard work can take you wherever you want to go, and that once you're grown up, you alone are responsible for your actions. In Mohammed's world, kids learn to identify themselves through the group, that you always depend on others as they depend on you; that you don't confront people directly; and GOD's will is paramount. These learned cultural attitudes are acquired over time in the formative years. Most people can't even explain why they behave or think in certain ways. This is also part of the reason why we project our own norms onto people of other cultures. If we don't remember formally learning these ways, it must have been

inborn and universally human. Another reason we attribute our own norms to foreigners is that people we've encountered have consistently behaved according to our expectations so why interpret things any other way.

7 Hasan Dindi, Maija Gazur, Wayne Gazur, Aysen Dindi, "Turkish Culture For Americans", (International Concepts, Boulder, Colorado, 1989), pp. V-VI.

8 Edward T. Hall and Mildred Reed Hall, "Understanding Cultural Differences", (Anchor Press Doubleday, 1977), p. 15.

9 Craig Storti, "Cross-Cultural Dialogues" (Intercultural Press, Yarmouth Maine, 1994), p. 112.

10 Ibid., p. 78.

11 Ibid., p. 84.

12 Ibid., p. 121.

13 Ibid., p. 22.

14 Ibid., p. 64.

15 Ibid., p. 69

16 Ibid., p. 67.

17 Craig Storti, "The Art of Crossing Cultures", pp 85-86.

18 Ibid., p. 112.

19 Ibid., p. 113.

20 Ibid., p. 81.



## Day 1, Panel 1 Question and Answers

(Transcript of Presentation)

Moderated by  
**Dr. James Willbanks—Command and General Staff College**

### **Dr. James Willbanks**

I think you'll agree those are three excellent presentations. What I'd like to do now is open the floor to questions. If you would please move to a mic, state your name and institutional affiliation, and who you would like to answer your particular question. Or the panel at large, whichever you so desire. Please, sir.

### **Audience Member**

Thank you. Tom Berner from the Afghanistan Reconstruction Group. This question is for Major Kron. There's a book that came out earlier this year by a fellow named James Bowman called *Honor: A History*, in which he discusses the concept of honor and particularly how it evolved in the West and how it's declined in the past 100 years or so. One of the points he makes is that one of the things that's really holding us back in the Middle East is our inability to grasp the honor concept. That we really are a post-honor society and find it very difficult to even conceive of what's behind this. I was wondering if you have any proposals for ways to sort of bridge the honor gap, so to speak, so that people going to the Middle East have a better concept of what sort of things to expect.

### **Major Hank Kron**

Well, my first reaction to that is American military personnel, I think, still have a sense of honor. It may be that American civilians ... that's waned in the civilian sector.

### **Audience Member**

That's really what my focus is on.

### **Major Hank Kron**

Okay. You know, this harkens back to maybe two or three generations ago in American society, where Americans understood these values. I like to think of it in terms ... Middle East values resides at the feet of the mother. The path to Heaven is at the feet of the mother. Preserving the honor of your whole family is through preserving the honor, the virtue, of your womenfolk. Cowboy movies used to show that kind of stuff. You violate some guy's wife or daughter or something, and

that's fighting words. It's fighting words. So the Hatfield and the McCoys, those kinds of things are in our history. If we've forgotten them ... they're not so alien. They're contained a lot in our cultural history, but I think you just need to bring these issues up to people that are deploying into the region and frame it in terms of how would you feel if someone raped your mother or sister? And then think of it as every man in the Middle East carries that kind of honor on his shoulder, on his cuff, at any moment. If you look for more than two seconds at a lady that you're not supposed to be looking at, you can invoke all sorts of emotions. And honor, in terms of any other activity, not just what we would think is preserving the honor of a lady, it all revolves around the ladies. Because why do I want to win battles? Fight. Why do I want to gain a reputation as a great person? To impress the ladies. To impress my mother. To impress my wife. It all revolves around that. So it takes a little bit of discussion. But I think people of even the X generation, I think, can get it easily enough.

**Mr. Kenneth Haynes**

I'd like to just add on that there's a logistical problem here. Sending a soldier to the Middle East, you'd like to train him on all this stuff. It takes a long time to train a soldier. In the case of the Saudi's, they're a cash customer. I say I want to send their team all to the Middle East Orientation Course for two weeks for a three month mission. That's not worth it to them. It really would be worth it to them, but ... of course, that course wouldn't give you nearly the insight that Major Kron has. So there's a big problem with that, of how much training we can afford to give our soldiers before they go over. How long it will take, how much they'll have to get. Thank you.

**Audience Member**

First, I really resent the shot about honor and the difference between the military and the civilians. I think that's totally out of line. Second thing, there is an issue here, which I think has been raised throughout this. This is a bureaucratic institution that's governed by certain rules in terms of tours and so forth. If you're talking about an honor culture where issues are individual and it's local knowledge and cultural knowledge and so forth, you really have a problem in establishing those connections when every 11 months, the person who has those connections is rotated out. That's a crucial point in the security assistance issue, which hasn't really been raised. How an organization that the structure is essentially to have very clear slots in an officer's career, and God help you if you miss one of those slots because you'll never get promoted, is now going to have to deal with his advising role. Which traditionally, by the way, it is always dumped on people and then shafted their careers once that thing is over. If you don't believe me, look at what happened to the guys who came out of Korea that worked with Korean Military Advisory

Group (KMAG) and worked with, in many cases, in Vietnam. Those guys were all ... and El Salvador.

**Major Hank Kron**

Sir, let me first respond by ... I certainly didn't mean to offend our American culture. I was responding to the question and said that perhaps it's waning in the American civilian side, but I was responding to the gentleman's observation. It's not my opinion, one way or another. So if you're offended, I apologize and I don't think ... that's not what I meant to say, if that's the way you understood it. I agree completely that in order to establish and nurture these relationships to be effective takes time. When I was the Deputy Chief of the Securities Systems Office in Qatar, these billets are two years. It takes at least one year for your counterparts to know and trust you. And now you're already on the downhill slope leaving. Just when you're becoming effective, you're leaving. However, there's a flip side to that. If you stay too long, if you homestead in a foreign culture, we run the risk of ... there's a definition of going native, and then you start to advocate on behalf of your client instead of your own organization. Also, you run the risks of getting too deeply imbedded in the culture and risking some compromises one way or another. My recommendation would be three years. One year to gain credibility and trust, one year to be optimum, and then one year on the downhill slope. Four years is probably too long. There are probably models to look at this, and other organizations outside the American Defense Department might have other factors and calculations. That's my experience as a military man. But I agree with you. It's something to factor in. The duration to accomplish this is a key factor.

**Dr. Donald Stoker**

You know, if you just look at the situation in Vietnam, as someone who participated in the Vietnamization effort and has looked at it in some detail, there are many numerous anecdotal cases of counterparts who were, as in my case, were on his 15<sup>th</sup> or 16<sup>th</sup> advisor over the ten year plus span of the war. So you kind of have to look at it from their perspective as well. There's a revolving door there that they have to respond to.

**Audience Member**

I have a question for Dr. Stoker. During the Cold War periods, security assistance was largely in terms of [inaudible] competition and for [inaudible]. In the post-Cold War era, to what extent is security assistance competitive?

**Dr. Donald Stoker**

To be honest with you, I don't think that I can answer that question. I never thought about it before. I know in the era before the Cold War, it's very much competition. But the post-Cold War era, I haven't looked at it that closely with the competition. There's certainly some, I think, in Egypt. Competition to get in there. But other than that, I really don't think I could give you a good explanation.

**Mr. Kenneth Haynes**

May I? What I've witnessed is that often times our Security Assistance offices are planning with their counterparts and factoring in deficiencies and gaps that the United States can help them with, and we're unaware completely of what the host nation is also planning and conducting with other sources. France, Russia, Great Britain, you name it. China, nowadays, as well. So the American Security Assistance offices are unaware and think that, well, they're simply not addressing the issue. They don't understand, they're not getting it. That's one dimension. The other dimension is our Security Assistance offices that we prepare at our institute, Defense Institute of Security Assistance Management (DISAM); the personnel that we train, they're agents and advocates, but they're not sales people. There are direct commercial sales that we monitor and track, but we don't track very well, or effectively, the sales activities of other nations, whether it's in our interests or whether it's competing. Sometimes it's not always a matter of competition. If Great Britain is filling a gap in one of our partner nation's deficiencies, fine. What's the difference? It's interoperable. We prefer US origin, but that's okay. But other times, with other suppliers, it might not be okay. But our offices are usually in the dark about this kind of issue. It gets into the murky world of salesmanship and marketing that our government offices are not willing to take part in. We do maintain awareness. Also, by the way, in the Middle East, we see increasingly French, British and Russian inroads into supplying what have been our traditional allies and friend's inventories, more and more.

**Dr. Donald Stoker**

There's a third party, too, and that is large, often US contractors, will sell things to ... offer their services and their materiel to the foreign government outside of the Security Assistance system. You'll see some cottage industries coming up overseas, where the foreign government suddenly is buying something that we could have arranged through Security Assistance, but because the contractor was there early and got their attention, got the business that way.



## **“After Saddam: Stabilization or Transformation?”**

### **Major Shane Story–US Army**

The collapse of Saddam Hussein’s regime in April 2003 was supposed to be a watershed event, a turning from tyranny to liberty, from dictatorship to democracy. It was an end that many dared not hope for, the defeat and humiliation of a despot who had slaughtered rivals and survived a long war, a quick defeat, and corrosive sanctions. Saddam surmounted trials that would have ruined a lesser tyrant, and employed multiple security organizations to protect his power. Still, in just three weeks of combat, Coalition forces shattered the regime. Analysts lauded the campaign, which became the personal triumph of Secretary of Defense Donald Rumsfeld.<sup>1</sup> When the difficulties had seemed greatest, and against all evidence, Rumsfeld insisted the Coalition was on the verge of success. Suddenly proven right, his prestige soared.<sup>2</sup> Observers wondered what would come next.

In Washington, Rumsfeld viewed the triumph as an opportunity to transform the Pentagon, to break entrenched Cold War-era policies and reshape the department for the conflicts of the twenty-first century. In Baghdad, Lieutenant General David McKiernan, commander of the Coalition Forces Land Component Command, faced daunting challenges in his efforts to stabilize Iraq. Rumsfeld, however, began withdrawing forces from Iraq in order to focus on transformation. Given his limited and dwindling resources, McKiernan minimized his objectives and emphasized cooperation with Iraqis and the international community. However, key policymakers rejected the compromises entailed in cooperation, and the Bush administration determined that worsening conditions in Iraq necessitated drastic changes. The administration asked Ambassador L. Paul Bremer to take charge in Baghdad, and the President gave Bremer a free hand. This paper reviews a complex series of events: the invasion and its attendant troop strength controversies, the impact in the field of Rumsfeld’s project to transform the Pentagon, and the difficulties of stabilizing Iraq. It argues that in May 2003—a moment when the United States enjoyed maximum leverage in Iraq—American policy as reflected in Rumsfeld’s transformation, McKiernan’s minimal stabilization, and Bremer’s grand project, reflected a self-defeating disunity of effort.

### **Planning Controversies: Long-Term and Short-Term**

Long before the present administration took office, the United States military faced serious force structure difficulties, and these difficulties fed the troop strength controversies surrounding the invasion of Iraq. In the 1990s, post-Cold War down-

sizing coincided with an expansion of security missions in the Balkans, Africa, and Asia. Many worried that frequent peacekeeping deployments were diverting troops from the essential task of preparing to fight and win the nation's wars, and they wanted to withdraw troops from the Balkans and elsewhere to save money and focus on war fighting. Beyond readiness, military leaders struggled with doctrinal, organizational, and equipment issues. These difficulties came to the fore in the spring of 1999, when the Kosovo crisis led to the emergency deployment of the ad hoc Task Force Hawk to Albania. An austere environment made the Army appear lumbering and clumsy, almost irrelevant to the on-going crisis. Kosovo, however, also illustrated the Army's need to deploy capable forces quickly. When General Eric Shinseki took over as Chief of Staff of the Army in June 1999, he tried to square the circle of missions, readiness, and modernization—and preempt future embarrassments like Task Force Hawk—through a process he dubbed “Transformation.” Transformation was controversial because it was about budgets. It demanded money, which could only come from expanding the budget or reducing operations, training, and readiness.<sup>3</sup> Budget issues ignited funding debates vis-à-vis the other services even as a new administration was pursuing tax cuts.

When Donald Rumsfeld became the Secretary of Defense in 2001, he chose to pursue radical transformation; he would create a new military, and he would pay for it by making the hard decisions that had stymied others' efforts. He was determined to withdraw ground forces from overseas peacekeeping missions and to reduce the military's personnel costs. These choices displaced long-standing security obligations and focused narrowly on specific kinds of threats.

Rumsfeld brought to office a unique perspective on the 1991 Gulf War. Most critics of that war faulted the administration for leaving Saddam in power, even as the military maintained a high regard for its performance as proof of its competence and professionalism. Rumsfeld criticized the war, however, not because Saddam was still in power, but because he thought the Army's logistics operations were a farce, an embarrassing monument to the military's mindless “planning,” its knee-jerk demands for more and more stuff that it moved around endlessly at incredible costs for no useful purpose.<sup>4</sup>

A final important element was Rumsfeld's disdain for the Pentagon and the men who ran it, the Joint Chiefs of Staff. After taking over as Secretary of Defense, Rumsfeld found that the Pentagon was “more broken than he had anticipated,” and he concluded that the service chiefs were part of the problem. In searching for a solution, Rumsfeld sidelined the service chiefs and began focusing his attentions on specific combatant commands, especially Central Command.<sup>5</sup>

These ideas—strong aversions to open-ended commitments, large numbers of personnel and massive operations, as well as marginalization of the service chiefs—shaped administration policy and drove the controversies that plagued planning for the invasion of Iraq. The existing war plan featured a long, deliberate build-up of large mechanized forces to defeat the Republican Guard. Rumsfeld vehemently opposed the existing plan, and pushed instead for the so-called Afghan model of using air power, Special Operations forces, indigenous allies, and a few conventional formations to win quickly and efficiently. Vigorous debates broke out among active duty and retired officers. Iconoclasts heralded new technologies and innovative tactics, while traditionalists warned that only overwhelming forces could mitigate the risks associated with deposing Saddam's regime. In the fall of 2002, General Tommy Franks adopted a compromise plan that would initiate an invasion with a small force but deploy additional forces quickly until the mission was complete.<sup>6</sup>

What followed was a debacle. Long before troops entered Iraq, two strategic choices fractured the very structure of the plan. The first choice concerned preparation. In order to give the President maximum flexibility and to make it possible to invade within days of a Presidential order, reserve logisticians, engineers, and transportation units would organize the theater support structure before the President made a decision. This support structure would provide a slingshot effect for combat forces heading to Baghdad. Most support units were in the reserves, and they needed months to deploy and organize the support system. Rumsfeld embraced Franks' faster timeline, but he balked at Franks' request mobilize and deploy support troops in late November 2002. Rumsfeld opposed calling up reservists and spent weeks fulminating against mobilizations. He complained that the military's structure was fundamentally wrong, and wondered whether reservists were necessary.<sup>7</sup> He had trouble seeing, he said, "why we have to have a reserve call-up anytime we want to engage in conflict. It simply tips off the fact that that is what we are going to do months before we are able to do it. From the standpoint of strategic surprise, I think that is foolish."<sup>8</sup> Publicly, the Chairman of the Joint Chiefs of Staff, General Richard Myers, was apologetic for the military's shortcomings, and began reviewing thirty years of force structuring decisions. Rumsfeld tightly controlled unit orders, demanding detailed justifications for each, and gradually began authorizing thousands of mobilizations and deployments each week.<sup>9</sup> A chasm separated Rumsfeld's office from those who should have corrected the notion that timely mobilizations—critical components of the plan—were foolish. Moreover, the President had already discarded strategic surprise before both Congress and the United Nations.

While the first strategic choice hobbled invasion preparations, the second choice crippled the prospects for stabilization. The plan assumed that force deployments would continue well after the regime fell and that troops would not begin redeploying before completing critical stabilization tasks. In January 2003, however, Rumsfeld incorporated “off ramps” into the force flow as a way of cutting off superfluous deployments and launching redeployments immediately after achieving strategic success. There was to be no follow through and no assumption of awkward strategic responsibilities. The Coalition was going to go in, get Saddam, and get out.

As international tensions rose, planning controversies and micromanaged deployment orders sowed confusion throughout the military. Combat forces rushed through deployments and final preparations. Reservists hurried to mobilization stations. Some received equipment and some trained, but most waited, because marginalizing the service chiefs left them helpless to coordinate the schedule. A few units began deploying, and they landed in debarkation stations left in chaos because the reserve units needed to organize them were still only half-mobilized. Many individuals and units struggled through a shocked deer-in-the-headlights confusion about their organizations, locations, and missions. Tremendous frustrations built up in military circles.

## **Invasion**

The frustrations melted away when the war began, as images of sharp soldiers filled the media and the sound and fury of precision bombardments gave substance to the Pentagon’s confident predictions. Adrenaline was high and cavalrymen speeding through the desert awed reporters and analysts. Rumsfeld predicted that Iraqis would soon topple Saddam and begin cooperating with the Coalition.<sup>10</sup> Various setbacks, however, complicated the tactical situation. Lost convoys, unexpected resistance, sandstorms, and supply shortages forced commanders to deal with a number of problems before closing on Baghdad. Days and nights of desert movements exhausted the troops, and V Corps and First Marine Expeditionary Force delayed their advances to address logistical challenges and dispose of threats to their supply lines.

Suddenly, newspaper headlines began sounding alarms about soldiers “Stuck in sand, lost in Iraq,” and “Soldiers Struggle to Rescue Patrol Marooned in Combat.”<sup>11</sup> Tactical problems brought into the open all the controversies that had roiled the planning for months, with critics charging that Rumsfeld had not sent enough troops. Rumsfeld replied it was Franks’ plan and predicted again that Saddam’s days were numbered.<sup>12</sup> The criticism grew as retired generals openly questioned

the size of the invasion force, and senior officers began predicting the fighting would last months.<sup>13</sup> A political uproar followed a commander's observation that the paramilitary threat had proven more serious than expected.<sup>14</sup> An escalating cycle ensued. Officers criticized fighting a war on the cheap, commanders described their challenges to reporters, critics attacked the planning and the lack of troops, and Rumsfeld stood steadfast, insisting, "the war plan is sound."<sup>15</sup> To make the situation worse, reporters described a humanitarian disaster in the port city of Umm Qasr. Rather than celebrating liberation, desperate mobs were begging soldiers for water, storming relief supplies and looting the city.<sup>16</sup> What critics did not appreciate was that American ground forces were now ready to continue their advance. Though anxious about chemical weapons, ground forces concentrated on conquering Fortress Baghdad.

In a few days of fighting, all the angst suddenly seemed overblown. American units seized their objectives using superior firepower and mobility and crushed Iraqi efforts to repel the American assaults. American forces captured Saddam International Airport at midnight on April 4, and an armored task force rampaged through Baghdad's western suburbs on April 5. Iraq's information minister delivered grandiloquent lies that made the regime the world's laughing stock. The final straw came when an armored brigade blasted its way to the Republican Palace. The information minister insisted the Americans were not in Baghdad even as camera crews filmed American tanks in the city center. When Iraqi counterattacks failed to dislodge the brigade and other units began heading downtown, Iraqi soldiers gave up fighting for a lost cause, the regime collapsed, and its leaders fled.

The psychological effect was astounding. Emboldened Iraqis turned on the regime and embraced liberation.<sup>17</sup> Defeat roiled the Iraqi military. An Iraqi major described going home to Tikrit. "As soon as I got home," he recalled, "I took my uniform off, went to my bedroom, and stayed there for five days. I was so shocked."<sup>18</sup> Despite knowing the Americans were invading, an Iraqi woman was stunned to see Marines in front of her house.<sup>19</sup> Americans were euphoric. Military units closed out their campaign histories and started getting ready to go home.<sup>20</sup> Analysts lauded Rumsfeld, and Rumsfeld's critics seemed naïve and uninformed for having failed to realize that Rumsfeld was leading the Pentagon into the future. Rumsfeld credited the plan, dismissed the importance of the individual services, and emphasized joint lessons learned.<sup>21</sup> Newspaper headlines trumpeted "Rumsfeld's Vindication," and "After the War, New Stature for Rumsfeld."<sup>22</sup> Rumsfeld crowed, quoting a note paraphrasing Winston Churchill, "Never have so many been so wrong about so much!"<sup>23</sup> A retired general thought that Rumsfeld had reached "the absolute pinnacle of power," and predicted that Rumsfeld would get "the bulk of what he wants."<sup>24</sup>

## **Transformation**

What Rumsfeld wanted was to complete the mission President Bush had given him in January 2001 to transform the United States military, to change its structure, the way it did business, the way it trained, the way it planned, and the way it fought.<sup>25</sup> First, he curtailed distractions from Iraq by cancelling First Cavalry Division's deployment orders, thus implementing the force flow "off ramp."<sup>26</sup> He directed the Pentagon to withdraw forces from Iraq, redeploy them home, demobilize reservists, and initiate major force shifts in Europe.<sup>27</sup> He began removing Army leaders by firing Army Secretary Thomas White and signaling that it was time for the Army Chief of Staff, General Eric Shinseki, to retire.<sup>28</sup> Other changes would follow.

Many of the things Rumsfeld wanted to change were grounded in the law and budgetary policies that only Congress could alter. Rumsfeld pressed Congress to change the law quickly to overhaul the Pentagon's management and personnel systems, the transfer of 300,000 jobs from uniformed to civilian personnel, and the expanded use of outsourcing, or contracting. When Congress balked, Rumsfeld explained that the Act was crucial for making the military "flexible, light and agile," able to "respond quickly and deal with surprise." In the information age, Rumsfeld complained, the Defense Department was "bogged down in the bureaucratic processes of the industrial age."<sup>29</sup>

In the months after Baghdad fell, Iraq's mounting difficulties demonstrated that the United States was facing serious policy dilemmas regarding resources, international support, and objectives. Rumsfeld, however, stressed Transformation. As he explained to the Senate Armed Services Committee, Operation Iraqi Freedom featured "an unprecedented combination of speed, precision, surprise, and flexibility." A modest invasion force was critical to success because "overwhelming power" was now more important than "overwhelming force." The proof lay in the fact that it had taken just over 100,000 troops on the ground to topple Saddam's regime. Boots on the ground were now less important than "advanced capabilities, and using those capabilities in innovative and unexpected ways."<sup>30</sup>

## **Stabilization**

The planning controversies, impaired deployments, and rushed redeployments limited ground forces in the campaign and undermined their operational readiness. In the view of Lt. Gen. David McKiernan, commanding the Coalition Forces Land Component Command, there was a gap between his limited forces' capabilities and what it would take to stabilize Iraq after Saddam fell. Since available forces could not fill that gap, McKiernan viewed his as a strictly limited mission. Security

and stability was going to require tremendous cooperation both from Iraqis and from the international community, and McKiernan envisioned his forces serving as a catalyst for many groups working together to stabilize the country. Two problems, one dealing with the United Nations and the port city of Umm Qasr, and the other one concerning the fate of an exiled Iraqi cleric, suggest the limits of getting help either from the international community or from Iraqis.

McKiernan tried to jumpstart stabilization from the first day of the invasion. While combat forces secured the oil fields, avoided southern towns, and drove on Baghdad, McKiernan wanted a humanitarian relief effort in the port city of Umm Qasr to portray liberation to the world, to rally international support, and to speed humanitarian supplies into the country. Iraq's poverty, however, dwarfed the imagination.<sup>31</sup> As the regime's security services collapsed, a looting frenzy spread like wildfire. Outnumbered Coalition forces ignored public disorder to focus on defeating military and paramilitary resistance. Ruined by economic sanctions and stripped by looters, Umm Qasr's port facilities were in shambles. Power lines went down, the port lost electricity, and an influx of refugees escalated the crisis. The British troops' humanitarian supplies were a pittance for the burgeoning number of civilians clamoring for food, water, and electricity. Relief depended on re-opening the port, but harassing fire and snipers delayed clearing mines and unexploded ordnance.<sup>32</sup> Critical shortages worsened as criminals diverted relief supplies to the black market.<sup>33</sup>

To McKiernan's partial relief, various non-governmental and international organizations had years of experience in Iraq and were eager to stave off a crisis by resuming the food distribution plan.<sup>34</sup> McKiernan wanted these groups' efforts would aid stability, and that stability would enhance security. However, strategic problems undercut McKiernan's efforts to work with these groups. The groups needed funding. The Bush administration, believing that Iraqi funds held in escrow by the United Nations should fund Iraqi relief, expected the Security Council to provide the funds.<sup>35</sup> These groups also relied on the Security Council to provide assurances that a given area was safe before aid workers entered the area.

While McKiernan was relying on the aid groups, and the aid groups were relying on the Security Council, the council remained mired in an impasse over Iraq dating back to the Gulf War of 1990-1991.<sup>36</sup> For twelve years, sanctions and inspections had isolated Iraq. Some council members wanted to end the sanctions and reintegrate Iraq into their strategic spheres; other members used the sanctions as a tool to contain and weaken Saddam. Through those years, Saddam's defiance lent drama to the discord as sanctions eroded Iraq's civil society.<sup>37</sup>

After the invasion, when Coalition officials sought stabilization assistance from the Security Council, they ran into the same impasse that had preceded the invasion. Council members who had opposed removing Saddam now balked at meeting American terms for stabilizing Iraq, and the council's control of sanctions, Oil for Food funds, and security authorizations for humanitarian relief, meant that Iraq would remain isolated until the council reached a new consensus. The Security Council would not recognize that any portion of Iraq was safe for the relief efforts that McKiernan was relying on until every veto-wielding council member had their say in shaping Iraq's future. Lacking the American resources required for the mission, McKiernan was relying on gaining resources, security authorizations, and consensus from the United Nations Security Council. In a shocking dichotomy, the operational commander was counting on the Security Council for support even as the administration was giving the Security Council a cold shoulder.

If international aid was going to be slow, the Coalition's other hope lay in building a political consensus among Iraqis to restore order. In one such effort, a Coalition security detail escorted the exiled Shia cleric Abdul Majid al-Khoei to the holy city of Najaf in early April. Representing one Shia sect, al-Khoei's family had long opposed Hussein's regime and had set up a philanthropic foundation in Britain. Apparently, the intent was for al-Khoei to convince Shia leaders to work with the Coalition to ensure public order. In Najaf, al-Khoei entered the Shrine of the Imam Ali on 10 April in a gesture of reconciliation with a senior Ba'athist. A mob set upon the men, hacking them to death with swords and knives, by most accounts at the instigation of Moqtada al-Sadr, a young cleric known since as a ruthless firebrand seeking to dominate Iraqi Shi'ism.<sup>38</sup> Whatever the motive behind the killing, whether it was a rejection of reconciliation with Ba'athists or of al-Khoei's westernizing influence, or merely a criminal effort to gain control of the Shrine's lucrative revenues, it portended a rising tide of Iraqis killing other Iraqis. Worse still was the Coalition's impotent non-response, because murderers acted with impunity.<sup>39</sup> Iraqis proved helpless to help themselves, much less the Coalition.

As the humanitarian crisis grew worse in Umm Qasr,<sup>40</sup> and Iraqi-on-Iraqi violence escalated, administration officials insisted the Coalition would control the stabilization mission while other countries called for the Coalition to defer to the Security Council.<sup>41</sup> The impasse continued. However, after M1 Abrams tanks thundered into Baghdad to shatter the regime, arguments about internationalizing the stabilization mission seemed like inconsequential diplomatic bickering. Military action appeared decisive. Franks asserted that the troops had accomplished every task assigned to them, and that there had never been "a combat operation as successful as Iraqi Freedom."<sup>42</sup> Rumsfeld used Baghdad's fall to re-launch transformation while minimizing America's commitment in Iraq.



From mid-April to mid-May, McKiernan and Lt. Gen. (Ret) Jay Garner, the Director of the Organization for Reconstruction and Humanitarian Assistance, struggled to encourage Iraqis to maintain order, and to persuade the Security Council to sponsor their efforts by ending sanctions, providing resources, and encouraging a broader coalition. Garner met with many Iraqis to coordinate stabilization, and worked with Ba'athist officials from various ministries. Coalition forces dealt with opposition militias and former Iraqi military personnel. McKiernan's and Garner's efforts at compromise and cooperation yielded few tangible benefits. A fuel crisis erupted, and security deteriorated. Absolving himself of responsibility, General Franks dismissed Iraq as ORHA's problem, but he did encourage President Bush to announce the end of major combat operations as a way of prodding other countries to assume the burden of reconstruction and humanitarian assistance.<sup>43</sup>

As the situation in Iraq grew worse, personnel turnover wrought havoc in the chain of command and on headquarters' staffs. Many key officers who had deployed specifically for the invasion, or who had been deployed since the fall of 2001, returned home. Franks retired.<sup>44</sup> When the White House named Ambassador Bremer to replace Garner in early May, it sapped Garner's credibility weeks before Bremer arrived or gained any understanding of the situation.<sup>45</sup> Apparently dissatisfied with both Lt. Gen. William Wallace at V Corps and McKiernan as the operational commander in Iraq, the Pentagon replaced them both with the commander of the First Armored Division, Maj. Gen. Ricardo Sanchez.<sup>46</sup>

By the time Bremer arrived in Baghdad, McKiernan was a "lame duck."<sup>47</sup> Naturally aggressive and believing that he wielded supreme authority in Iraq thanks to mandates from President Bush and Rumsfeld, Bremer set out to demonstrate that he was in control.<sup>48</sup> Without any understanding of McKiernan's and Garner's challenges and strategies, Bremer purged Ba'athists from public life and disbanded the Iraqi Army. Large segments of the Iraqi population, including most of those who had run Iraq for decades, became *persona non grata* in Bremer's new Iraq. Alarmed at Bremer's precipitous actions, McKiernan publicly warned that disbanding the Army exacerbated Iraq's on-going economic and security crises. Asked by reporters whether McKiernan disagreed with Bremer, a Pentagon official insisted that Bremer had McKiernan's complete support.<sup>49</sup>

A week later, his time in Iraq ending, McKiernan thought the situation was getting worse and worried that officials and the public did not adequately appreciate the dangers posed for the United States in Iraq. He warned reporters that combat was continuing, that it demanded every resource available, and that "The war has not ended."<sup>50</sup>

## Conclusion

There are two important caveats to bear in mind regarding the situation in Iraq before drawing any conclusions about the events of May 2003. The first one is that Iraqis themselves are the foremost reason for the Iraqi tragedy. The source of Saddam's power was his ability to exploit schisms within Iraqi society, and his rule made those schisms worse. The Iraq the Coalition invaded may have been an enslaved nation with an educated middle class sitting on untold oil wealth, but it was not ready at a moment's notice to leap from oppressed tyranny to self-funded, fast-growing representative democracy. Coalition troops found a country wracked by significant pockets of endemic poverty and illiteracy, beset by economic and health crises, and suffering from a pervasive lack of legal status for persons or property. Nationalism and fanaticism fueled the suffering as Iraqis terrorized Iraqis. Kanan Makiya, an Iraqi ex-patriot living in the United States, described his fears long before the invasion. He feared the catastrophe of Saddam Hussein remaining in power, but he also feared that Saddam's end would unleash a "giant, unpredictable and powerful whirlpool" that would suck "everything into its raging vortex beginning with the people of Iraq."<sup>51</sup> Makiya feared Iraq's schisms would consume Iraqis and the region.

The other caveat concerns American policy making in general. After watching multiple administrations' flounder in their attempts to define their policy on Iraq, Makiya concluded that the United States was conspicuous in "its unwillingness and possibly even [its] structural inability" to calculate what would America's interests be in Iraq after Saddam, and to formulate a coherent policy designed to protect those interests.<sup>52</sup> Far from condemning American policy or policymakers, this suggests how daunting a problem it is to clarify or discount American interests in Iraq.

The two factors that dominated the Pentagon's response to the regime's collapse were Rumsfeld's aversions to open-ended commitments and to large-scale military operations. These factors led to the suspension of additional deployments and the rapid shift to redeployment operations. As Rumsfeld set out to reenergize Transformation, he removed key Army leaders throughout the chain of command. The competing priorities that were dividing American policy surfaced in the third week of May 2003. Transformation being the top priority, Rumsfeld insisted the country could not afford to let any distraction hinder his overhaul of the Pentagon. Taking a different view, the chair of the Senate Foreign Relations Committee, Senator Richard Lugar, warned that violence and instability in Iraq were increasing, and the administration was putting victory at risk because it was severely underestimating the mission.<sup>53</sup> Unfortunately, even as Lugar was warning about insufficient resources, Ambassador Bremer was greatly expanding the mission by

purging Ba'athists, disbanding the Army, suspending elections, and putting off recognizing Iraqi leaders.<sup>54</sup>

Judging by Iraq's history and the recent history of stability operations, it was inevitable that stabilizing Iraq would be difficult. The mission was even more difficult because it had to follow an invasion in the face of broad international and regional opposition. Nonetheless, tactical success and Baghdad's fall opened a window of opportunity, one that General Petraeus defined as the first critical thirty days when he took the 101<sup>st</sup> Airborne Division to Mosul. In that crucial moment, however, the mission became harder when Rumsfeld and Bremer pulled the workhorse of the American military in opposite directions, with Rumsfeld trying to transform the Pentagon, and Bremer trying to transform Iraq.

## Endnotes

- 1 Greg Jaffe, "Rumsfeld's Vindication Promises a Change in Tactics, Deployment," *Wall Street Journal* (10 April 2003), 1.
- 2 Matthew Purdy, "After the War, New Stature for Rumsfeld," *New York Times* (20 April 2003), A1.
- 3 Michael E. O'Hanlan, "Modernizing and Transforming US Forces: Alternative Paths to the Force of Tomorrow," in *QDR 2001: Strategy-Driven Choices for America's Security*, ed. Michèle A. Flournoy, 293-318 (Washington, D.C.: National Defense University Press, 2001).
- 4 Bob Woodward, *Plan of Attack* (New York: Simon & Schuster, 2004), p. 2; Thomas P. M. Barnett, "Donald Rumsfeld: Old Man in a Hurry," *Esquire* (July 2005).
- 5 Dana Priest, *The Mission: Waging War and Keeping Peace with America's Military* (New York: W. W. Norton & Company, 2003), p. 23; Woodward, *Plan*, p. 6, quote p. 17; Tommy Franks with Malcolm McConnell, *American Soldier* (New York: ReganBooks, 2004), pp. 207, 275-78, 301, 383, 440-1; Michael DeLong with Noah Lukeman, *Inside CentCom: The Unvarnished Truth about the Wars in Afghanistan and Iraq* (Washington, D.C.: Regnery Publishing, 2004), pp. 86, 102.
- 6 Franks, *American Soldier*, pp. 409-11.
- 7 Michael R. Gordon and General Bernard E. Trainor, *Cobra II: The Inside Story of the Invasion and Occupation of Iraq* (New York: Pantheon Books, 2006) 95-97; Woodward, *Plan*, 231-232.
- 8 Memorandum, Secretary of Defense to David Chu, Subject: Reserve v. Active Duty Tasks, December 30, 2002. See "Mobilization Reform: A Compilation of Significant Issues, Lessons Learned and Studies Developed Since September 11, 2001," Office of the Secretary of Defense, Reserve Forces Policy Board (October 2003).
- 9 John Diamond, "Logistics to delay Iraq war schedule," *USA Today* (13 January 2003), A1; Thom Shanker, "US Considers Limits on Role of the Reserves," *New York Times* (26 January 2003), 1.
- 10 DoD News Briefing – Secretary Rumsfeld and Gen. Myers (21 March 2003), [http://www.defenselink.mil/transcripts/2003/t03212003\\_t0321sd1.html](http://www.defenselink.mil/transcripts/2003/t03212003_t0321sd1.html); "Special Report: Pentagon Admits Highest Hopes for Iraq War Have Not Been Met," NPR News Special Coverage (21 March 2003).
- 11 Ann Scott Tyson, "Stuck in sand, lost in Iraq," *Christian Science Monitor* (24 March 2003), 12; Brian MacQuarrie, "Soldiers Struggle to Rescue Patrol," *Boston Globe* (26 March 2003), A19.
- 12 DoD News Transcript - - Secretary Rumsfeld Interview with Tim Russert, NBC Meet the Press (23 March 2003), [http://www.defenselink.mil/transcripts/2003/t03232003\\_t0323nbc.html](http://www.defenselink.mil/transcripts/2003/t03232003_t0323nbc.html).
- 13 Vernon Loeb and Thomas E. Ricks, "Questions Raised About Invasion Force," *Washington Post* (25 March 2003), A17; Richard T. Cooper and Paul Richter, "Former Commanders Question US Strategy," *Los Angeles Times* (26 March 2003), A10; Thomas E. Ricks, "War Could Last Months, Officers Say," *Washington Post* (27 March 2003), A1.
- 14 Richard T. Cooper and Esther Schrader, "The 'Whens?' of War Blow Up a Storm,"

Los Angeles Times (29 March 2003), A5.

15 Jonathan Weisman, "Rumsfeld Insists War Plan is Sound," Washington Post (29 March 2003), A24; DoD News Transcript - - Secretary Rumsfeld Remarks on Fox News Sunday with Tony Snow (30 March 2003), [http://www.defenselink.mil/transcripts/2003/t03302003\\_t0330sdfox.html](http://www.defenselink.mil/transcripts/2003/t03302003_t0330sdfox.html).

16 David S. Cloud, "Struggle to Open Key Iraqi Port," Wall Street Journal (1 April 2003), A1.

17 DoD News Briefing – Secretary Rumsfeld and Gen. Myers, (9 April 2003), <http://www.defenselink.mil/transcripts/2003/tr20030409-secdef0084.html>.

18 Scott Peterson and Peter Ford, "From Iraqi Officers, Three Tales of Shock and Defeat," Christian Science Monitor (18 April 2003), 1.

19 Interview with an Iraqi woman, name withheld by request, by the author (14 June 2005).

20 See, for example, CPT Rob Steffel, "Battalion History for 1-39 FA (MLRS) During Operation Iraqi Freedom" (21 April 2003),.

21 Vernon Loeb, "Rumsfeld: Plan Put Iraq Off Balance," Washington Post (16 April 2003), 31.

22 Mathew Purdy, "After the War, New Stature for Rumsfeld," New York Times (20 April 2003), A1.

23 Vernon Loeb, "Rumsfeld Assails War Critics and Praises the Troops," The Washington Post (29 April 2003), A11.

24 Victor Davis Hanson, "Don Rumsfeld, radical for our time," National Review (5 May 2003), p. 31; Peter Boyer, "The New War Machine: A Reporter at Large," The New Yorker (30 June 2003), p. 55; Dave Moniz and John Diamond, "Rumsfeld is perched at 'pinnacle of power'," USA Today (1 May 2003), A10.

25 Woodward, Plan, 33-35; Priest, Mission, 24-27.

26 DoD News Transcript, "Rumsfeld and Myers." (15 April 2003), <http://defenselink.mil>

27 Eric Schmitt, "Rumsfeld Says US Will Cut Forces in Gulf," New York Times (29 April 2003), A19; Esther Schrader, "US Expedites Reshuffling of Europe Troops," Los Angeles Times (1 May 2003), A1.

28 John Hendren, "Air Force's Roche is Offered Army Secretary Post," Los Angeles Times (2 May 2003), A19.

29 Donald Rumsfeld, "Defense for the 21st Century," Washington Post (22 May 2003), A35.

30 Statement of Secretary of Defense Donald R. Rumsfeld, 9 Jul 2003, pp. 1-2, posted at <http://armed-services.senate.gov/statemnt/2003/July.pdf>.

31 The quote pertains to a nearby village, Safwan, but corresponds to accounts of the situation in Umm Qasr as well. See Geoffrey Mohan and Tony Perry, "Convoy Rumble on an Unyielding Pace," Los Angeles Times (22 March 2003), A1.

32 "Coalition forces near Basra," CBC News (22 March 2003), [http://www.cbc.ca/stories/03/21/umm\\_qasr030321](http://www.cbc.ca/stories/03/21/umm_qasr030321); Victor Mallet, "Ominous Signs for Coalition in Battle for Umm Qasr," Common Dreams News Center (23 March 2003). <http://www.commondreams.org/headlines03/0323-01.htm>; "Coalition Forces Secure Umm Qasr," Online Newshour (25 March 2003). [http://www.pbs.org/newshour/updates/umm\\_qasr\\_03-25-03.html](http://www.pbs.org/newshour/updates/umm_qasr_03-25-03.html)

- 33 David S. Cloud, "Struggle to Open Key Iraqi Port May Put Most Aid Weeks Away," *Wall Street Journal* (1 April 2003), A1; Yaroslav Trofimov, "In Iraqi Port City, Looters and Bandits Meet Little Resistance," *Wall Street Journal* (3 April 2003), A1.
- 34 "Coalition Forces Secure Umm Qasr," *Online Newshour* (25 March 2003). [http://www.pbs.org/newshour/updates/umm\\_qasr\\_03-25-03.html](http://www.pbs.org/newshour/updates/umm_qasr_03-25-03.html)
- 35 Colum Lynch and Kenneth Bredemeier, "US Hits Snag in U.N. on Aid for Iraq," *Washington Post* (26 March 2003), A29.
- 36 UN Security Council Resolutions 660 and 661 (2 and 6 August 1990), <http://www.un.org/Docs/scres/1990/scres90.htm>; UN Security Council Resolution 687 (3 April 1991), <http://www.un.org/Docs/scres/1990/scres90.htm>.
- 37 For a concise examination of the complexities surrounding Iraq policy in the 1990s, see Stephen C. Pelletiere's *Managing Strains in the Coalition: What to do about Saddam?* (Carlisle Barracks, PA: Strategic Studies Institute, 1996).
- 38 "Obituary: Abdul Majid al-Khoei," *The Economist* (19 April 2003), 88.
- 39 Ian Fisher, "Iraqi Says He Stalks and Kills Ba'ath Party Men, With Toll at 12," *New York Times* (1 May 2003), A17.
- 40 Patrick Nicholson, "Umm Qasr aid effort 'a shambles,'" *BBC News* (4 April 2003), [http://news.bbc.co.uk/2/hi/middle\\_east/2915091.stm](http://news.bbc.co.uk/2/hi/middle_east/2915091.stm)
- 41 Susan B. Glasser and Rajiv Chandrasekaran, "Reconstruction Planners Worry, Wait and Reevaluate," *Washington Post* (2 April 2003), A1; David E. Sanger and John Tagliabue, "Bush Aide Says US, Not U.N., Will Rebuild Iraq," *New York Times* (5 April 2003), B1; Marcella Bombardieri, "Relief Organizations Struggle to Aid an Unstable Southern Iraq," *Boston Globe* (6 April 2003), A32; Edward Walsh and Peter Slevin, "U.N. Role in Postwar Government Debated; White House Claims Authority on Rebuilding," *Washington Post* (7 April 2003), A24.
- 42 Franks, *American Soldier*, 523.
- 43 Franks, *Soldier*, 523-5.
- 44 *Ibid*, 531.
- 45 Bremer, *Year*, 15.
- 46 Gordon, *Cobra II*, 487.
- 47 Interview with Lt Gen David McKiernan by the author (20 June 2003).
- 48 Ambassador L. Paul Bremer with Malcolm McConnell, *My Year in Iraq: The Struggle to Build a Future of Hope* (New York: Simon & Schuster, 2006), p. 13.
- 49 Scott Wilson, "Order Dissolving Iraq Military Raises Other Worries," *Washington Post* (24 May 2003), A18.
- 50 Scott Wilson, "US Commander to Step Up Action Against Iraqi Attackers," *Washington Post* (30 May 2003), A16.
- 51 Kanan Makiya, "Does Iraq Have a Future?" (1994), reprinted in *The Saddam Hussein Reader: Selections from leading writers on Iraq*, ed. Turi Munthe (New York: Thunder's Mountain Press, 2002), 514.
- 52 Makiya, p. 519.
- 53 Richard G. Lugar, "A Victory at Risk," *Washington Post* (22 May 2003), A35.
- 54 Bremer, *My Year*, 19, 39-49.

## **Training Indigenous Forces: Selected Examples From the British, American and Russian Experiences**

**Dr. Robert F. Baumann—Command and General Staff College**

The problem of organizing, equipping, and training indigenous forces is hardly a new phenomenon. Globally, utilizing indigenous forces has been on the standard task list for powerful, expansionist states and empires virtually from the beginning of recorded history. Logically, the study of the employment of subjugated or assimilated ethnic groups for military purposes has received considerable scholarly attention during the past several decades. In fact, a description of the great variety of cases discussed by historians is well beyond the scope of this essay. The intent of this study is to examine a small group of nineteenth- and twentieth-century cases in search of useful, or at least noteworthy, observations concerning the processes and results of such endeavors. By design, this paper will focus on cases entailing a significant cross-cultural component. On the surface, at least, such cases appear to be both more challenging and more interesting as a result of efforts to seek organizational solutions within the context of separate or diverging cultural norms.

### **The British Experience**

Few countries have compiled a lengthier record of training other peoples' armed forces than the British. From the Americas to Africa, from India to Japan, British trainers have successfully molded indigenous personnel into able combat units on land and at sea. To be sure, most of this extraordinary variety of training missions was a function of imperial necessity. In an age when "the sun never set on the British Empire", there simply were not enough Red Coats to go around. Looking back from an historical perspective, the forces that held the future commonwealth together were astonishingly small. Indeed, the entire imperial edifice almost appears to have been a product of "smoke and mirrors," a magician's illusion.

In reality, the imperial foundation was more solid than that, although the power of perception played a considerable role in the success of British governance. Because its wealth and resources were not unlimited, and because the point of empire was the expansion of British wealth, imperial strategists sought sensible economies in their methods of conducting business. One of the most successful means was the cooption of local populations to serve as part of the defensive bulwark of the crown's authority.

No portion of the empire yielded a larger crop of trained indigenous units than India. Initially undertaken by the East India Company, the training of native Indian units became a vast enterprise. Indeed, by the Napoleonic Wars, the East India Company possessed one of the world's largest standing armies, most of which consisted of native units. Among the reasons that the East India Company relied heavily upon native manpower were economy and the fact that it was not permitted to open a recruiting station in England until the end of the eighteenth century.<sup>1</sup>

Given the great size and enormously varied population of India, the British adopted more than one approach to the organization of military units. Broadly speaking the critical variables were the purpose of the intended military unit and the local culture of the populace in question. One especially noteworthy aspect of culture was the nature of pre-existing armed formations. In other words, did a given people have a strong martial tradition and how were its warriors organized?

The British were reasonably quick to discern the importance of cultural context in the development of military training programs. This meant that they found a way to work around issues of caste in India, making concessions to prevailing societal norms as necessary, particularly in Bengal before the Mutiny. Moreover, they tended to follow the path of least resistance when it came to specific kinds of employment. In other words, tribesmen of the Northwest Frontier were more likely to be organized into mounted scout formations than conventional infantry or artillery. Conversely, urban dwellers in Bengal were not particularly suited to service on the rugged mountainous frontier.

A crucial watershed in the organization of forces in India was the mutiny of 1857, during which a number of Bengali regiments rallied to resist British authority. In the aftermath, the British philosophy towards recruitment underwent a fundamental shift. Urban elites, particularly high-caste Brahmins and Rajputs, fell out of favor for the simple reason that many had associated themselves with the mutiny. Moreover, the overall composition of the Indian Army drifted away from roughly balanced representation of castes, ethnic groups and religious faiths towards a program favoring those who were later dubbed "martial races."<sup>2</sup>

The Peel Commission, named for the British Major General who presided, convened in 1858 to consider the future of native armies of the three presidencies, Bengal, Madras and Bombay. Not surprisingly, most of those units that had participated in the mutiny were dissolved. The matter of how best to fill the reconstructed army with recruits was to some extent left to evolution. Change was most pronounced in Bengal, which of course had been the epicenter of the recent trouble. There, Punjab residents and Muslims slowly emerged as the recruits of



choice. Service remained voluntary, meaning that to a significant extent selection had to be mutual for a recruit to enter military service.<sup>3</sup>

In the last analysis, it would be fair to say that “martial race” theory crystallized as a description of emerging reality, rather than as a well-articulated doctrinal or philosophical basis underlying a strategy for the recruitment of native Indians. In part, the theory was based on popular notions of anthropology and psychology, especially the premise that some of the Indian races were inherently warlike while others were not.<sup>4</sup>

According to this view, Sikhs and Gurkhas were among the paragons of martial spirit and tradition, as were many Muslim tribes in the Punjab or along the Afghan frontier. Certainly, the Sikhs and Gurkhas possessed rich military histories as well as cultures that placed a powerful premium on warrior status. In general, this meant that basic values of the British military system—discipline, self-sacrifice, valor—were already fully instilled in Indian recruits and required only continued emphasis by British trainers to ensure their continuous expression. There is much to argue that these martial values formed the cultural bridge between British trainers and native soldiers. Put differently, cross-cultural communication, and especially the degree of trust required to create a sense of esprit in a military unit, proceeds best where there are mutually recognized values that can transcend basic differences.

Still, presence of a martial tradition did not alone make for a successful partnership, which still depended upon a variety of fortuitous circumstances. One population among whom recruiting efforts failed were the Mappilas of Madras, practitioners of strict Islam with a history of resistance to Hindu domination. As it happened, British suppression of a rebellion among the Mappilas in 1800 poisoned the relationship with the army. As a result, subsequent efforts to raise regiments among the Mappilas aborted.<sup>5</sup>

Of course, military collision could also lead to mutual respect. Such, apparently, was the product of British campaigns to subjugate the Sikhs in 1845, which resulted in annexation of the Punjab to the empire. In this instance, recruitment of native troops flourished as explained by British Major-General Vincent Eyre:

The new Punjabee regiments, composed partly of Sikhs and partly of Mohammedans, with a sprinkling of Hindoos and Goorkhas, and subjected to the wholesome discipline and intelligent guidance of picked English officers, proved a most successful experiment. The new force soon established, and has since maintained, a first-rate reputation for efficiency and fidelity; and those same soldierly qualities which

had rendered them the most formidable of foes, elevated them when enlisted on our side, to the highest rank of merit in the Native Army of India.<sup>6</sup>

As Eyre went on to explain, the state of more or less continuous warfare in which peoples of the Punjab lived invigorated their martial spirit and made them formidable fighters. This conclusion aligned perfectly with later explanations put forth as part of “martial race” theory.

Early in the twentieth century, the results were manifest. As David Omissi observes, “By the outbreak of the Great War, the Punjab (which contained only one-thirteenth of the entire population of the subcontinent) supplied nearly half the recruits of the Indian Army.”<sup>7</sup>

Another central tenet of the conventional British explanation for the success of indigenous units in India concerned the relationship of British officers with the natives under their command. As noted by historian Jeffrey Greenhut, “. . .the phrase typifying the modern western army, ‘You salute the uniform, not the man in it,’ was essentially foreign to Indian culture.”<sup>8</sup> This was partly a function of native traditions, in which a superior would take on roles beyond that of commanding officer such as mentor or patron. Consequently, the importance of personal rapport and individual charisma on the part of officers appears to have been paramount

Though in part a product of self-serving British martial mythology, the notion of the valiant officer winning the undying loyalty of native troops seemed to have some basis in fact. As Greenhut notes, replacing officers with whom such soldierly bonds had formed was problematic.<sup>9</sup>

There is some evidence that this pattern particularly prevailed in scout units along the frontier, where British officers in some instances served tours extending as much as a decade or more. Some individual officers thrived in such environments that placed a premium on ability to act independently and to adapt to native ways and conditions.

### **The American experience**

Although the focus of this article is not on the American experience, a few American examples are worth noting if only because they lend a measure of supporting evidence to substantiate the broad applicability of trends observed in Eurasia, Central Asia and the subcontinent.

US Army officers serving on the frontier in the Western plains operated in an environment much like that of British officers on the northwest frontier. Although less likely to serve for long periods in locations far removed from regular military units, they nevertheless depended inordinately on personal self-sufficiency and an intuitive ability to coexist with the natives in order to succeed. Those possessing the requisite gifts enjoyed the confidence and even devotion of those whom they led. To be sure, leadership in these circumstances was particularly subtle. To be in command meant to exercise overall responsibility for major decisions even while relying extensively on indigenous personnel to inform those judgments. Put another way, the commanders remained extremely dependent upon the good will and special skills of those over whom they presided.

Historian Thomas Dunlay observed, "Effective leadership of Indian scouts depended far more on the personal qualities of the leader than on his formal, legally based authority...in the regular forces the insecure or obtuse officer could fall back on the authority of his commission and the harsh disciplinary measures that regulations and custom made available. With Indian scouts these sanctions could easily produce the opposite of the desired result..."<sup>10</sup> However, by playing to the strengths of scout units, officers could foster outstanding morale and performance.

One with extensive experience in the matter was Lieutenant Samuel Robertson, who described the training of Crow scouts under his command. Setting the correct tone began with recruitment. Describing an address to Crow Chiefs, Robertson recounts, "I spoke for a half-hour, explaining to them thoroughly the nature of the new service I asked them to engage in. I did not conceal from them any of its objectionable features, realizing how essential absolute frankness is with the Indian character; but I appealed to their pride, dwelt upon the honorable, manly nature of the soldier's profession, and asked if they would not consent to become a part of the right hand of their great government..." As for the subsequent training regimen, he explained, "It is no exaggeration to say that...no troop of cavalry that I ever saw performed as many of these movements on horseback with more precision than they...Mounted drills they never seemed to weary of, and it was a positive privation to them when from any cause they were forced to be absent from them."<sup>11</sup>

The cultivation of military capabilities among the Indians did not always meet with the approval of social reformers, however. For example, the recruitment of members of the Pawnee scouts from the agency school pleased the young warriors but not their civilian supervisors. Dunlay notes, "To the educators, this running off

to fight Sioux and collect scalps was simply a reversion to savagery; reintegration as Pawnees was the last thing they wanted for their pupils.”<sup>12</sup>

For the United States, the alignment of military and societal objectives sometimes proved as problematic in overseas scenarios as at home. One of the more intriguing American attempts to build a foreign army was the organization of the *Garde d’Haiti* by US Marines in Haiti in the 1920s and 1930s. Following a Marine-led intervention in Haiti in 1915, the United States assumed responsibility for reconstructing a country ravaged by political chaos and a collapsed infrastructure. Naturally, American motives were as much strategic as altruistic, a foremost concern being that some other power such as Germany might move into the Haitian vacuum and create a military threat in the Caribbean.

According to a treaty imposed on the Haitians, the establishment of a new army commenced in February 1917. Initially, all 123 commissioned officers in the *Garde d’Haiti* were American. The first three Haitian officers received commissions in 1923, but only in 1931 did Haitians at last constitute a majority of their own officer corps.<sup>13</sup>

In general, the Marines did a remarkably good job training the Haitians. By the American departure in 1934, the *Garde d’Haiti* was by most accounts fully competent not only to defend the country (which in fact needed little defending) and to manage internal police functions such as operating prisons as well. Paradoxically, however, the efficiency of the *Garde* eventually became a national liability. As historian Bryant Freeman argues, as Haiti’s most efficient institution, the army also became the ideal instrument of repression for Haitian rulers.<sup>14</sup> This unintended outcome resulted from the failure of the United States to bequeath to Haiti a fully functioning governmental system. In fairness, nation building has never been easy and Haiti has proved to be one of history’s most intractable cases as more recent experience in the 1990s has shown.

### **The Russian Empire**

Russia’s experience in the development of armed formations from among various foreign nationalities to some extent blended those of the British Empire and the United States. Like the British, the Russians used indigenous forces as a fundamental, long-term of their imperial military establishment. In turn, like the United States, the Russians experimented with transitional units from among some populations along their contiguous frontiers. These were never construed as permanent.

Among the most interesting cases in the Russian Empire was that of the Bashkirs, who were employed in a series of stages on the road to full assimilation into the regular military system. An historically nomadic or semi-nomadic people situated near the northern fringe of the modern Kazakh steppe, the Bashkirs came into sustained contact with the Russian Empire not long after the fall of the Khanate of Kazan in 1552. The establishment of a permanent Russian fortress at Ufa, near the confluence of the Belaia and Ufa Rivers, in 1586 initiated a process of absorption that continues to this day. Despite the pragmatic decision of some Bashkir chieftains to swear allegiance to the Tsar, the relationship remained problematic for over two centuries. Friction between Bashkirs and Russian settlers persisted, as evidenced by Bashkir participation in periodic peasant uprisings against the empire. The most infamous of these was the Pugachev Rebellion of 1773 that raged across the southern expanse of the empire and briefly threatened to topple Catherine the Great.

From 1798, the Bashkirs were formally organized into administrative cantons in the same manner as the Cossacks, an hereditary military class that pledged to perform military service for Russia in exchange for a large measure of civil autonomy. As needed, the Bashkirs provided Russia with squadrons of irregular cavalry. By all accounts, the Bashkirs were superlative cavalymen. As British observer Sir Robert Wilson wrote, “troops who could like them banquet on horse-flesh, dressed or raw, sweet or tainted, requiring not either bread or wine for sustenance, might indeed be called savages, but would have at their command all the luxuries of other nations.”<sup>15</sup>

Operating across the broad expanses of the empire, the Bashkirs were unsurpassed in their ability to navigate with stealth and quickness. Attended by mullahs on campaign, the Bashkirs were extraordinarily resourceful and self-sufficient.<sup>16</sup>

In combination with regular formations of the Russian Army, the Bashkirs rendered outstanding service. They were notable participants in the campaigns of 1812-1813 to drive Napoleon out of Russia and Bashkirs were among those elements of the army that eventually paraded through Paris with Tsar Alexander I at their head. Subsequently, at one time or another, the Bashkirs provided small detachments in support of campaigns in Central Asia and elsewhere. Still, the War Ministry determined not to include them in campaigns against the Ottoman Empire during the Crimean War out of a desire to avoid sending Moslems to fight Moslems.

During this period, the Russians made no attempt to impose conventional regulations on the Bashkirs, who were entitled to serve in the manner that suited them

best and took greatest advantage of their existing combat capabilities. Rather, a principle of gradualism applied that envisioned a conversion of the Bashkirs to regular service as part of a long-term vision.

A dramatic change in the manner of Bashkir service to the empire occurred in 1874 with the establishment of a system of universal liability to military conscription. While some Bashkirs cantons were subject to the draft, others were marked to provide recruits for an irregular mounted squadron. In the estimation of War Minister Dmitri Miliutin, the architect of Russia's new system of military service, this was a transitional measure en route to full assimilation.<sup>17</sup> Accordingly, Miliutin abolished the squadron in 1881 in favor of full inclusion in the universal draft lottery. Subsequently, Bashkirs participated in the army on the same basis as Russians and other integrated nationalities.

The Bashkir model of service also worked well for certain other nationalities such as the Crimean Tatars. Of course, one secret success was the gradual imposition of conventional rules and regulations over many decades.

The Russians were less successful in the more southerly reaches of Central Asia where the edict of 1874 explicitly excluded the natives from the draft lottery or any obligation to serve in the army. This was due, in large part, out of respect for the difficulty of converting the natives to military service as well as out of concern for the possible consequences of doing so. Russia's most distinguished commander of the late nineteenth century, General Mikhail Skobelev, explicitly advised against the training of tribes such as the Kazakhs. In Skobelev's estimation, the Kazakh tribes would slowly cease to regard their trainers as intrinsically superior and eventually apply their new skills against the Russians.<sup>18</sup>

Thus, the Russians made no effort either to conscript Central Asians or even to establish the principle of an obligation to serve prior to World War I. Unfortunately, as the carnage continued and the empire faced an urgent need to replenish its military manpower, the Central Asian exemption was increasingly perceived as an unaffordable luxury. Consequently, Russia announced a Central Asian draft in 1916. Even though the proclaimed intent was to employ Central Asians primarily in rear area duties such as construction, the step triggered a furious backlash. Within weeks small acts of rebellion burst into a full conflagration. Ultimately, the catastrophe of Central Asian conscription forced the diversion of precious resources away from the Western front to restore domestic order in the empire.<sup>19</sup>

Curiously, the mistake was repeated in 1920, though by a different regime. Just two years after the Russian Revolution, the Reds attempted to introduce military

conscription in Central Asia in order to consolidate their power. Acting on the assumption that their public support for national self-determination would obviate any hostile reaction, the Bolshevik regime boldly announced its own conscription campaign. The result, however, was even worse than that sparked by the tsarist decree. A full-fledged resistance movement arose. Known as the *basmachestvo*, the movement represented an eclectic alliance of reformists, hard-line clerics, criminal gangs and an assortment of tribal leaders. In all, it took the Red Army thirteen years to extinguish the final flickers of armed resistance in Central Asia.

Even so, the idea of employing Central Asians, especially the nomadic populations, in the Red Army did not fade away. One commentator, D. Zuev, continued to extol the military virtues of Central Asian nomads in an official periodical in 1923. In particular he noted their “wonderfully developed vision,” initiative, and indifference to the attraction of religious fanaticism that plagued the employment of some sedentary native populations.<sup>20</sup>

In the meantime, one of the Russian Empire’s most remarkable training experiments came to a close early in the twentieth century. Established in 1882, the so-called Persian Cossack brigade more resembled a modern security assistance mission. Indeed, it was a superb example of a military-diplomatic mission.

Set against the backdrop of intense Anglo-Russian competition for influence at the court of Naser ed-Din Shah, the ruler of Iran, the brigade became a central element of Russian diplomatic strategy. In the first place, Russia had to compete for the Shah’s favor in order to win the contract to establish a foreign-trained, western-style military unit. Naturally, the brigade also served the perceived self-interest of the Shah himself. According to a foremost scholar of imperial politics in Iran, Yale Professor Firuz Kazzemzadeh, the Nasr ed-Din shah was attempting to acquire some of the trappings of European modernity. In fact, he was the first Persian head of state to travel to Europe.<sup>21</sup> By the mid 1880s, the unit was well-drilled and fully capable. As such, it served Russia’s diplomatic intentions. Nevertheless, it inevitably became embroiled in local politics at several levels. First, it became an object of contention between the unit commander and the Russian ambassador, who feared the growing influence of his military counterpart. Second, recruitment from among members of native elites for positions in the unit gradually posed a disciplinary problem that was rectified only with a decision altering the recruiting base and the terms of service. Third, and finally, as one of the most capable military units in the Persian capital, the unit was drawn into several power struggles and ultimately played a critical role during the revolution of 1905-1911.

## **Summary**

Based upon this episodic survey of the experiences of British, Americans and Russians in the training of military formations drawn from foreign populations several provisional observations emerge. First, all three states found the richest, or at least the readiest, opportunities for military training among populations that already possessed strong military cultures of their own. Second, all three enjoyed considerable success by recruiting among populations that were largely rural or nomadic, even if recruits were not readily employable in regular military units. Third, based on the limited research sample described here, individual leadership, characterized by superior cross-cultural adaptability, proved to be of paramount importance in the creation of cohesive and effective units.



## Endnotes

- 1 Raymond Callahan, *The East India Company and Army Reform, 1783-1798* (Cambridge, MA: Harvard University press, 1972), 5-6.
- 2 For a useful discussion of “martial race” theory, see David Omissi, “‘Martial Races’: Ethnicity and Security in Colonial India 1858-1939,” *War and Society*, Volume 9, Number 1 (May 1993), 1-26. For a highly readable, if non-scholarly, overview, see Byron Farwell, *Armies of the Raj From the Great Indian Mutiny to Independence: 1858-1947* (New York: W. W. Norton & Co., 1989) and Roger Meamont, *Sword of the Raj: The British Army in India, 1747-1947* (New York: The Bobbs-Merrill Company, Inc, 1977)..
- 3 Ibid., 2-6 and Stephen P. Cohen, *The Indian Army: Its Contribution to the Development of a Nation* (Berkeley, CA: University of California Press, 1971), 36-41. A second commission, the Eden Commission, affirmed the central findings of the Peel Commission in 1879.
- 4 Omissi, 6-9.
- 5 Ibid., 10-11.
- 6 Major-General Vincent Eyre, “The Sikh and European Soldiers of our Indian Forces,” *Journal of the Royal United Service Institution*, Volume XI, 1868, 90. For discussion of the participation of native troops in frontier campaigns, see T. R. Moreman, *The Army in India and the Development of Frontier Warfare, 1849-1947* (London: King’s College, 1998).
- 7 Omissi, 12-13.
- 8 Jeffrey Greenhut, “Sahib and Sepoy: an Inquiry into the Relationship between the British Officers and native Soldiers of the British Indian Army,” *Military Affairs*, Volume 48, Number 1 (January 1984), 15-18.
- 9 Ibid., 18.
- 10 Thomas W. Dunlay, *Wolves for the Blue soldiers: Indian Scouts and Auxiliaries with the United States Army, 1860-90* (Lincoln, NE: University of Nebraska Press, 1982), 91-92. In one documented instance, Crow and Shoshone scouts informed General Crook that they would scout against the Lakota in their own fashion, not wishing to be hindered the cavalry. See Charles M. Robinson III, *General Crook and the Western Frontier* (Norman, OK: University of Oklahoma Press, 2001), 179.
- 11 Richard Upton, Ed. *The Indian as a Soldier at Fort Custer, Montana, 1890-1895: Lieutenant Samuel C. Robertson’s First Cavalry Crow Indian Contingent* (El Segundo, CA: R. Upton, 1983), 63, 46.
- 12 Dunlay, 153.
- 13 United States Marine Corps. *Republic of Haiti*, monograph 801-100. Compiled 1932. Contained in the special collection, Combined Arms Research Library, Ft. Leavenworth, Kansas. For a good overview of the Marine effort to build the Haitian Army, see James McCrocklin, *Garde D’Haiti, 1915-1934* (Annapolis, MD: The United States Naval Institute, 1956).
- 14 Professor Bryant Freeman, Interview with Dr. Robert Baumann, Ft. Leavenworth, Kansas, May 5, 1997. Copy held in the Combined Arms Research Library, Ft. Leavenworth, Kansas.
- 15 Sir Robert Wilson, *Brief Remarks on the Character and Composition of the Russian*

*Army and a Sketch of the Campaigns in Poland in the years 1806 and 1807* (London: T. Egerton Military Library, 1810), 40.

16 For a discussion of the Bashkir cavalry under the tsars, see Robert F. Baumann, "Subject Nationalities in the Military Service of Imperial Russia: The Case of the Bashkirs," *Slavic Review*, Volume 46, Number 3/4, Fall/Winter 1987, 489-502.

17 For a discussion of the introduction of universal military service among the various nationalities of the Russian empire, see Baumann, "Universal Service Reform and Russia's Imperial Dilemma," *War and Society*, Volume 4, Number 2 (September 1986), 31-49. For discussion of the conversion of Cossack forces to regular service, see Robert McNeal, "The Reform of Cossack Military Service in the Reign of Alexander II," in *War and Society in East Central Europe*, ed. Bela Kiraly and Gunther Rothenberg, (New York: Brooklyn Press, 1979) I, 412-416. The standard work on the universal service reform is P. A. Zaionchkovskii, *Voennye reformy 1860-70 godov v Rossii* (Moscow: Moscow University Press, 1952).

18 A. Shemanskii, "Skobelev I ego mysli 1879-81," *Voennnoistoricheskii vestnik*, no. 1 (1912), 22.

19 For an overview of the military campaigns against the Basmachis, see Robert F. Baumann, *The Russian Soviet Experience in Unconventional Wars in the Caucasus, Central Asia and Afghanistan*, Leavenworth Paper Number 20 (Ft. Leavenworth, KS: Combat Studies Institute, 1993).

20 D. Zuev, "Istochniki komplektovaniia krasnoi armii v turkestane," *Voennaia mysl' I revoliutsiia*, Number 11, August 1923, 164.

21 Firuz Kazemzadeh, "The Origin and Early Development of the Persian Cossack Brigade," *American Slavic and East European Review*, Volume 15, No. 3 (October 1956), 352. For the full context of Anglo-Russian competition, see Kazemzadeh, *Russia and Britain in Persia, 1864-1914* (New Haven, CT: Yale University Press, 1968).

**No Infidels Left and the War Goes On: Soviet Military Assistance to the Democratic Republic of Afghanistan After the Withdrawal of Soviet Forces, 1989-1992**

**Dr. Jacob Kipp—Foreign Military Studies Office**

*“You thought they (the resistance) hated us because we were Communists. The truth was that they hated us because we were foreign occupiers.”*

— M. A. Gareev

**Introduction: the Context**

Geography has defined the fate of Afghanistan. It is a rugged mountainous country in which terrain helped to divide the population along clan, tribal and ethnic lines, making for weak central authority and rivalries for power. For much of its pre-modern history, Afghanistan was part of the great caravan trading routes that made up the Silk Road. Nineteenth-century Afghanistan found itself as the frontier buffer between two empires, the Russian and British. In this Great Game, neither power had the ability to impose its rule upon the peoples of Afghanistan. Both were willing to aid those resisting the advance of the other power. In the age of railroads, which became arteries of imperial advance by uniting diverse peoples and creating national economies, Afghanistan resisted railway development and remained isolated and under-developed. In the Cold War, Afghanistan became a buffer between the competing superpowers with the Soviet Union and the United States providing aid in competitive ventures in nation building. The Kingdom of Afghanistan enjoyed two decades of modest development in its cities and in the road network that tied its urban centers together. Within Afghanistan, reformers, drawn from the urban elites, sought to bring about a national revival without picking sides. Political developments in the 1970s led to the overthrow of the Afghan monarchy, the establishment of a republic and a rapid radicalization of internal politics as various groups and factions looked to external support.

The April Revolution of 1978, a military coup by radical officers within the Army and Air Force against Daoud Khan’s government, overthrew the republic, established the Democratic Republic of Afghanistan (DRA) and brought together a factionalized Afghan Communist movement, the People’s Democratic Party of Afghanistan (PDPA) and set in motion a plan for the construction of a socialist Afghanistan allied with the USSR. Many of the officers involved in the coup had been educated in Soviet military schools where they had received both profes-

sional and political education. Soviet military advisors and weapons figured in the coup, and in the post-coup era the number of advisors and the deliveries of military equipment increased rapidly. Soviet intervention, one year later, came at a point where a rural insurgency was taking hold and when the factions of the PDPA were engaged in a bloody internal struggle over power in Kabul. The Soviet military intervention in December 1979 occurred to ensure a stable Afghan government that would be a reliable partner of Moscow. The effort was a coup de main to change the government in Kabul and not a military operation to fight the emerging civil war. The General Staff's study of the forces needed for the pacification of Afghanistan called for 30-35 divisions to seal the borders with Iran and Pakistan; occupy the post important urban centers; airfields; and communication centers; prevent the entry of external forces; and disarm the resistance. But such a course of action did not fit the Politburo's political objectives. As Marshall Nikolai Ogarkov told General Gareev, "This is not the time when anyone at the top will agree to such a course."<sup>1</sup> Rather, an aging Soviet leadership rejected such a course of action and substituted a smaller force that intended to provide sufficient stability for the Afghan government to reorganize and impose its role upon the entire country. The smaller force conveyed limited objectives to the outside world and accurately reflected the ability of the Afghan theater to support combat forces with an underdeveloped infrastructure, especially the transportation system. By the spring thaw of 1980 it became apparent that the Army of the DRA could not suppress the insurgency, and the Limited Contingent of the Soviet Armed Forces in Afghanistan found itself drawn into the struggle and had to abandon any immediate plans for Afghanization of the conflict. The three-plus divisions initially deployed were reinforced to five and two third division equivalents with most of this force deployed to garrison urban centers and to protect the extended lines of communications (LOC) from Soviet Central Asia to the regime's areas of control.

Foreign governments, led by General Zia al Huq's Pakistan and including the United States, various Arab states, Iran, and China provided assistance to the resistance and the war evolved into a contest to deny the opposing side logistical support. Caught up in an insurgency, which they could not cut off from external support, Russian commanders decided that the best strategy to catch the insurgent "fish" was to drain the Afghan "sea" by attacking the civilian population supporting the Mujahadeen and driving them into exile. The Soviet-DRA forces drove the part of the population supporting the mujahadeen—about six million persons—into exile in Pakistan and Iran. The mujahadeen did the same to supporters of the DRA, swelling an internal refugee population to about 2.2 million around the urban centers. The population of Kabul doubled during the war. The Mujahadeen remained a loose alliance of competing tribal and ethnic groups, united by their opposition to the Soviet occupation and the socialist revolution but divided over any

other objective. Some embraced Islamic fundamentalism; others did not. The war dragged for nine years. International efforts to bring about the Soviet withdrawal were ongoing and culminated in the Geneva Accords of 1988, which set in motion the withdrawal of the Soviet 40th Army but did not end Soviet assistance to the DRA or foreign assistance to the mujahadeen and that war continued for another four years.<sup>2</sup>

On the eve of the Soviet intervention the population of Afghanistan was about 17 million with just over two million living in cities and large towns. Kabul, the capital, had a population of about one million. The rest of the population was rural with about 2.5 million of that living a nomadic existence. Afghanistan's population was overwhelming Muslim but hardly fanatical. Most Afghan Muslims were Sunnis, with the Hazarras making up a Shia minority, living in the central mountains and speaking an archaic Persian. The ethnic composition of the population included Pashtuns, who made up close to half the population and lived predominately south of the Hind Kush and composed the dominant social group and ruling elite. A sizeable Pashtun population, even before the war, lived outside Afghanistan in Pakistan's northwest frontier. The Pashtunwali, farmers and nomads, their tribal culture stressed warrior virtues. The Tajiks, living north and west of Kabul, made up the second largest ethnic group and provided the merchants and artisans of Afghanistan. The Tajiks spoke Dari, the second official language of Afghanistan, and the one most used in the urban centers, especially Kabul. The Uzbeks, living in the northeast, spoke a Turkic language and were largely nomads with cultural ties to the Uzbeks of the Soviet Union. The war would exact a terrible price upon this population, as noted about six million refugees and over two million internally displaced persons and another 1.5 million dead.

### **The Literature on Soviet Military Assistance and Failure**

There is a rich literature on the "failure" and "defeat" of Soviet forces during the Soviet intervention in Afghanistan. The initial literature written during and immediately after the conflict saw the struggle through Cold War lenses.<sup>3</sup> In the immediate aftermath of the end of the Cold War and the emergence of ethno-national conflicts insurgencies and local wars, another line of argument emerged regarding the continuing conflict in Afghanistan that pointed towards the emergence of asymmetric warfare.<sup>4</sup> What followed were more in depth analysis of the Soviet-Afghan conflict. Many of these studies drew upon lessons learned by the opposing sides. One volume addressed the tactical and operational lessons of the war as compiled by the staff of the Frunze Academy. A second provided a look at the tactics of the Mujahadeen. A third looked at the war from the operational and strategic perspective of the Russian General Staff.<sup>5</sup> Two of the leading experts on the Soviet-Afghan

conflict have concluded that the failure of Soviet forces to pacify Afghanistan rested upon the military's unwillingness and inability to adapt to counter-insurgency operations. The authors make their case even more compelling by pointing out that the General Staff's lessons from Afghanistan first appeared in English translation and have yet to be published for broad dissemination in Russia.<sup>6</sup>

On the basis of this analysis, some have concluded that the Soviet failure in Afghanistan was the precursor to the dismal performance of Russian forces in Chechnya, and suggested that the Soviet experience is essentially a template of what not to do in counter-insurgency operations. If US and coalition forces avoid such mistakes in Afghanistan and Iraq they will be on their way to success in contemporary asymmetric warfare. Stephen D. Pomper has observed that Soviet lessons learned are a litany of failure and one key part of that failure was the training of Afghan forces. "Many of these 20-year-old learning points are negative. Put bluntly, the Soviets' inability to train indigenous Democratic Republic of Afghanistan (DRA) military forces was but one facet of a larger, well-documented failure."<sup>7</sup> The Soviet military as the heirs of Zhukov's tank armies and forged by the demands of preparing for modern mechanized war against NATO simply could not do what tsarist armies had done successfully in the 18th and 19th centuries – adapt their doctrine to the demands of war in an undeveloped theater of war against an irregular opponent, which had adopted a strategy of attrition and partisan warfare. "Soviet military experts knew what to do to win in Afghanistan but did not do it because of a cultural reluctance—in other words, cultural inertia."<sup>8</sup> The author goes on to argue that the US forces "should avoid following the bear into these woods" but provide "proper training" for the Afghan and Iraqi militaries.

The problem is defining what proper training for each military in each society is in order to create an effective indigenous military capable of meeting and overcoming the threats, which they must face internally and externally. Often this simply presupposes that professional military training is objectively self-evident and the model for a new army. Yet recent articles have suggested a much more complex mix of forces for what is now called "the long small war" against insurgents. Here the mix of forces needed includes conventional, special, and indigenous forces drawn from among enemy defectors. The last element is deemed necessary because of their special knowledge and intelligence value in the particular society.<sup>9</sup> The author draws these conclusions on the basis of an analysis of French experience in Vietnam and Algeria and American experience in the Philippines and Vietnam. The core point remains: Does the nature of the host society and its culture not impact upon the creation of an effective indigenous force to conduct counter-insurgency operations? Do a Muslim Algeria with its French colons and the Philippines in the aftermath of Spanish colonial rule present similar cases? Certainly French

and American experiences with indigenous forces in Vietnam invite comparisons. Recent studies have been less positive on Vietnam. The charge of cultural inertia might also be applied to the US experience with training the ARVN, which survived US military withdrawal from Vietnam but collapsed under the impact of a combined arms offensive by the armed forces of the DRVN when denied support by US airpower.<sup>10</sup> And the supreme test of indigenous counter-insurgency forces is their ability to conduct a successful campaign after the withdrawal of the intervening force that has trained them. Such a campaign must have a political content that strengthens the legitimacy of the government as it attempts to get the insurgents to give up their struggle. The indigenous population in all its social, ethnic, and religious complexity becomes the center of gravity for the struggle.

### **Russian Commentators on Military Assistance**

Russian military commentators have seen the problem differently and disagree with the assessment of Afghanistan as a military defeat. They stress the impact of political decisions limiting the size of the force deployed; ideological assumptions about the nature of the conflict and the applicability of a Soviet model of a centralized socialist state to Afghanistan in the face of divergent histories and cultures; and political decisions by the Soviet government to withdraw in 1988-1989 and by the Russian government to abandon the Democratic Republic of Afghanistan and its armed forces in 1992 to explain the outcome. Boris Pastukhov, Soviet Ambassador to Afghanistan from 1989 to 1992, described Soviet policy as caught up in knot of contradictions: "The Afghan knot of contradictions encompassed international, political, ideological, socio-economic and military aspects. . . . Unfortunately, in all of these areas and especially in the political there were many unforgivable mistakes."<sup>11</sup> These authors point to the fact that the Afghan state and army outlasted its Soviet patron and the Soviet Armed Forces. They argue that the very fact that the Afghan government and army survived for so long after the withdrawal of Soviet forces means there had some measure of success in creating a viable state and military. They argue that the chases for the survival of the regime of President Najibullah increased precisely at the point where the mujahadeen resistance, divided by clan and ethnic rivalries, lost the unifying power of resistance to a foreign occupier. Russian authors, while recognizing a military bias towards a military art developed to fight large wars, point to a different cultural problem, a failure initially to take into account Afghan history and culture. One commentator, who has made this point, is General Makhmut A. Gareev, Russian Army (retired).

Gareev arrived in Kabul in February 1989 to serve as chief military advisor to the DRA and remained there until 1991. Gareev, who is now President of the Russian Academy of Military Sciences, has written two books devoted to the Soviet-

Afghan War, paying particular attention to the post-1989 phase, when Najibullah put into action a different political strategy in keeping with the “feudal” nature of Afghan society and embarked upon a strategy of divide and rule. This involved abandoning many of the so-called reforms of the April Revolution that had brought the People’s Democratic Part of Afghanistan to power in 1978. Gareev argues that Soviet military and economic assistance played a positive role in the survival of the regime and that its withdrawal brought about not only the collapse of the Najibullah government but also intensified civil war, social collapse, and the disintegration of Afghan statehood.<sup>12</sup> Gareev’s experience in Afghanistan influenced his subsequent work on the nature of future war and local wars.<sup>13</sup> Between these two positions of abject failure and limited and temporary success there is some small truth that may have relevance to US forces and polices in Afghanistan and perhaps Iraq. This paper will address that issue.

### **Russian Lessons from Afghanistan**

Only a week after the terrorist attacks of September 11, when it was already clear that the United States would intervene in Afghanistan against Al Qaeda and its ally, the Taliban, an article appeared in the Russian newspaper *Izvestiia*. The author of the article, Maksim Iusin, a leading Russian journalist on international security enumerated “five lessons of Afghanistan” drawn from the Soviet experience. The first lesson was to avoid a protracted war. The Americans had to realize that you cannot win a war in Afghanistan if by win you mean occupy the country. Attempting that would only lead to a protracted guerilla war. The author thought the American forces could do this if they confined their mission to destroying Al Qaeda and the Taliban by quick and decisive action and then departed. However, American success would depend upon Afghans understanding that goal. “The main point is that Afghans understand this—not some mullah representatives to the government of the Taliban, but the ordinary people of the country.” If the Afghans did not take the Americans for foreign occupiers then there was a good chance of avoiding large-scale guerilla warfare.<sup>14</sup> Not surprisingly Russian experts do not completely agree with this assessment. They point to political decisions that constrained the size of the force deployed, imposed ideological constraints on military decision-making, and finally led to the political decision to disengage and then to abandon the Afghan government and its armed forces. Moreover, they argue that lessons were learned, that the government of the Democratic Republic of Afghanistan and its armed forces were able to survive the withdrawal of Soviet forces and, in fact, outlasted both the Soviet state and the Soviet Armed Forces.<sup>15</sup> In short, they suggest that some things were done right. Between these two positions is, in fact, some common ground, and this paper will address them by focusing upon Soviet military assistance after the withdrawal of 40th Army in February 1989.



The second lesson involved using others forces as much as possible to fight the war. By this the author meant enlisting Afghans to conduct the fighting. The author pointed out that when the Soviet 40th Army withdrew from Afghanistan it left behind a fully capable Afghan Army to continue the war. With great effort and much cost and thanks to the assistance of hundreds of Soviet military advisors the Afghan Army of President Mohammad Najibullah had become a combat-capable force. "It could independently (almost independently) oppose the Mujahadeen."<sup>16</sup> To support this point the author cited the military successes of the Afghan Army between 1989 and April 1992. The Afghan Army had, against all foreign expectations, successfully defended Jalalabad from Mujahadeen attack in 1989. The Najibullah government only collapsed in the spring of 1992, when the new Russian government abandoned the Soviet client regime, withdrew the last advisors and refused to sell it oil to sustain its forces and run its economy. The author pointed out that the Americans had no such regime or army in place but could make use of the forces of the Northern Alliance to carry the fight to the Taliban and Al Qaeda and provide air power to supports its operations. That movement could also serve as the basis for a successor government once the Taliban was defeated.

The question of a successor regime led the author to his third lesson: Do not fear the decentralization of Afghanistan. The author pointed to Western business interests that had tried to do business with the Taliban to ensure a united country to further commercial gains and concessions, especially pipelines across the country, had sustained a government that was both terrorist and dangerous for their entire region and beyond. He might also have pointed to the policy followed by Najibullah after the Soviet withdrawal, which involved making accommodations against some war lords in order to win their support against other, more intransigent elements of a divided resistance. The author recommended that the American support Afghanistan's separate identities and make alliances with regional governors who could ensure stability and order in the various parts of the country. Trying to impose a strong centralized government on Afghanistan would only lead to such leaders going over to the opposition of the new government in Kabul.<sup>17</sup> A decentralized Afghanistan would be stable and not a threat to the region or a likely base for a global terrorist movement.<sup>18</sup>

The fourth lesson stated by Yusin underscored the impact of Afghan society on the combat stability of formations. Put simply, Afghans could be bought. Throughout the period of the Soviet intervention and during the years when the Najibullah regime fought alone without Soviet forces in the field, Afghan governors, tribal elders, and field commanders frequently changed sides. The author recalls an incident from 1989 when foreign reporters were brought out to witness the declaration by one 800-man band of its loyalty to the regime. "The guests from Kabul

were fed plov and lamb. Shots were fired into the air.” One of the fighters who had studied in Russia and learned Russian turned to the reporter and said “Do you know why we came over to Najibullah? They sent us weapons and money. But if Hekmatiar or Rabbani (two of the leaders of seven major mujahadeen factions) offer us more money then we will fight against Najibullah.”<sup>19</sup> Najibullah also tried to follow the same policy in his dealing with the two major factions of the People’s Democratic Party of Afghanistan, the Khalqis (nation) and the Parchamis (banner), which Soviet ideologues had identified as the officer corps and working class vs the intelligentsia and bourgeois democratic element. The Khalq faction claimed to be the more radical and Leninist. Pashtuns from non-elite clans made up most of the Khalq wing of the PDPA. Their Marxist ideology was tinged with deep resentment for their inferior status. The Parcham faction had strong support in Kabul University and drew support from the urban elite, including Tajiks, Uzbeks, and Pashtuns. Gareev, who had first-hand experience in Najibullah’s delicate dealing with these factions, having staged coup and counter-coup since the April Revolution, had recommended in a jest that the President steal a page from Alexander the Great and use marriage to aid pacification. In this case by marrying wives from each faction, thereby acknowledging the clan, tribal, and ethnic divisions within the government’s own camp. Najibullah, himself a Pashtun of the Ghilzai tribe, was part of the small minority of Afghans who had adapted to modern urban life. He had graduated from Kabul University with a degree in medicine in 1975 but had joined the Parcham faction of the PDPA in 1965. The political jockeying among the party factions led to his exile in 1978. He returned after the Soviet intervention and was appointed head of the KHAD, Secret Police, where he gained a reputation as “the bull” for his ruthless suppression of dissent. However, as head of the KHAD, he also had a unique perspective on the actual situation in the country. When he became President in 1988, he used those insights to radically change internal policy in anticipation of the withdrawal of Soviet forces. His object was regime survival in a hostile environment.

The final lesson involved shaping the international context of the fight within Afghanistan. The author called for the neutralization of Pakistan. Yusin stated that as long as Pakistan served as a sanctuary and base of supply for the Mujahadeen, Soviet forces could not win the war. With the United States, other western countries, China, and most of the Arab world providing arms and supplies through Pakistan, the mujahadeen had the opportunity to regroup, rearm, and plan new attacks and raids against their opponents. The US could, thanks to its ties to the Pakistani government, get it to give up support to the Taliban and Al Qaeda. The author, however, pointed out that President Musharraf could act decisively under current, post-9/11 circumstances but would soon face pressure from Pakistan’s radical Islamists to give support to the resistance if the fight continued.<sup>20</sup>

Written on the eve of American intervention against the Taliban and Al Qaeda in Afghanistan, these lessons have a special relevance for ensuing operations and for the reemergence of the Taliban insurgency with its sanctuary in the Northwest Frontier of Pakistan. The five lessons provide a political, social and international context to Gareev's comments on the military lessons of Afghanistan. It should be pointed out that Russian journalists in the aftermath of the initial successes of the US intervention in Afghanistan were quite certain that there were no lessons that the Americans could learn from Soviet experience. Alexander Golts wrote of a stunning and rapid victory that had put the plodding Soviet Army and its Afghan allies to shame. Golts noted the success of a few hundred US Special Forces in routing the Taliban in comparison with Soviet tank regiments and artillery preparations. He pointed out the clearly defined goal of US forces in destroying the Taliban and Al Qaeda vs. the political-military muddle from Moscow. Most of all, he emphasized the limited mission: "Unlike the so-called 'humanitarian interventions,' the goal of rebuilding the state system in Afghanistan and creating a new government were seen as an accessory and not a must-have. From the very beginning Washington made it clear that American forces would not participate in any peacekeeping operations in Afghanistan."<sup>21</sup> The Americans would be in and out in a short time with decisive results. If that, of course, had been the case then Gareev's observations would have been irrelevant to the American experience and this symposium.

### **My Last War: Gareev on Soviet Military Assistance after Soviet Withdrawal**

The Russian General Staff has provided a brief but telling summation of the Soviet military assistance to the Afghan Armed Forces during the Soviet Intervention. The study addresses the organization, composition, and training of the force.<sup>22</sup> The study places the strength of force at between 120,000 and 150,000 troops, depending on the season, casualty rate, the success of conscription, and the degree of desertions and defections. Grau and Gress state that the official strength of the Army in 1978 was officially 110,000 but the number of available troops was closer to 80,000. They estimate Army strength to have been about 40,000 during the Soviet intervention, supplemented by 7,000 in the Air Force, 15,000 in the forces of the Ministry of Internal Affairs, 4,000 in the border guards, and another 40,000 in tribal militias.<sup>23</sup> The Armed Forces were organized into four corps, composed of 13 infantry divisions and 22 brigades. There were also 40 separate regiments and 30 separate battalions and squadrons operating under a complex system of subordination to the Ministry of Defense, Ministry of Internal Affairs, Ministry of State Security, Border Guards, and territorial militia. These units were habitually under their official TO&E strength, explained in part by a monthly desertion rate of 1500-2000. The force was equipped with Soviet arms, including 800

tanks, 130 BMPs, 1200 AFVs (BDRMs & BTRs), over 2600 artillery tubes and rocket launchers, and 300 aircraft. The underdeveloped Afghan economy and the lack of technical skills among conscripts created serious problems in maintaining the combat effectiveness of the equipment park. A significant minority of Afghan officers had been trained in the Soviet Union and the Afghan Ministry of Defense maintained a number of schools for professional officer education, including combined arms, air force and air defense, and logistical and technical support. Students at Kabul's universities and technical schools were also exposed to reserve officer training. Commander's training was conducted at officer assemblies during each training cycle and on a weekly basis within units with the goal of enhancing combat skills and improving command and control. Russian observers complained about nepotism in career advancements and noted serious shortcomings in the training of non-commissioned officers, a problem not effectively addressed in the Soviet military. They also called attention to poor political education, which failed to instill in officers and troops a sense of the cause for which they were expected to fight. Conscription was another weakness. Divisions and brigades resorted to sweeps through mujahadeen-controlled territory to meet their unit's conscription needs by pressing the unlucky and the slow into service. This guaranteed no small number of mujahadeen sympathizers in the Army's ranks. In 1984, the regime turned to raising territorial militias in areas control by the mujahadeen factions, willing to change sides. Such territorial forces were composed of a core that remained in their assembly area with the rest at home waiting for the call to arms. The leadership of this units included regular Army officers, local elders, and former mujahadeen commanders. Soviet military advisors were assigned down to separate battalions and served with the Afghan unit in the field. This was difficult service, involved significant personal risk because of mujahadeen sympathizers in the ranks, and was not considered a path to rapid professional advancement in the Soviet Army. By the eve of the departure of the 40th Army, a major re-supply and rearming of the Afghan Armed Forces had gone forward. In short, the Armed Forces of the DRA, while well equipped, faced serious handicaps in taking up the full struggle with the mujahadeen.

The political context of the Soviet withdrawal was Mikhail Gorbachev's decision to lessen East-West tensions in order to engage in fundamental reform within the Soviet Union under perestroika and glasnost'. On coming to power Gorbachev had asked the military for an assessment of the forces and means necessary to rapidly end the conflict. By 1987 Gorbachev was looking for a political solution that included the withdrawal of Soviet forces in exchange for US disengagement. The internal element of this policy in Afghanistan was the campaign by President Najibullah for national reconciliation. As Najibullah made clear in his discussion of this policy with Gorbachev, the decisive factor was "the problem of achieving a

decisive turning point in the psychological mood of the population.” The President judged this to mean by dividing the opposition and “launching decisive strikes on irreconcilable groups. This is the psychology of the Afghan people.”<sup>24</sup>

In order to appreciate Gareev’s analysis one needs to know something about the man and soldier. A tartar by birth, in 1938 Gareev entered the Tashkent Infantry School in Uzbekistan, where Soviet forces only a few years before had been battling Central Asian insurgents, the *basmachestvo*. Gareev graduated in 1941 and immediately went to the front and combat in the Battle of Moscow. In the war with Nazi Germany he fought from Moscow to Königsberg, rising to the rank of captain, suffering four serious wounds and being decorated for bravery. In July 1945, Major Gareev moved east as part of 5th Army’s staff and in that capacity fought against the Kwantung Army in Manchuria. In 1946, he was involved in training units of the Mao’s People’s Liberation Army. His successful career included service as military advisor to the Egyptian Army during the confrontation along the Suez Canal. Gareev graduated from the Frunze Academy and the General Staff Academy and became one of the leading military theorists of the Soviet Armed Forces and Chief of the Director of Military Science of the General Staff. The operational maneuver group (OMG) concept of the 1980s was also known among Soviet staff officers as “operativnoe myshlenie Gareeva” [Gareev’s operational thinking]. He was the author of many leading studies, including a major study on the theoretical legacy of Mikhail Frunze. He had taken part in a number of missions to Afghanistan during the Soviet intervention. His career involved a solid combination of military theory and practical combat experience in a wide range of theaters against a broad spectrum of opponents.<sup>25</sup> In short, Gareev brought a wealth of experience to his new mission as military advisor to Najibullah.

Gareev began his tenure as military advisor to Najibullah in February 1989 at a time, when the Mujahadeen and most foreign observers anxiously awaited the rapid collapse of the Democratic Republic of Afghanistan. The Afghan government was nothing more than the unpopular tool of local Communists and the Soviet Union and was expected to fall momentarily. By this account, the Soviets had been driven from the field by the appearance of stinger missiles, which had negated Soviet airpower. The Afghan Army, a hollow shell, was expected to collapse as soon as the spring campaign season began. The politburo understood the need to reinforce the regime and its armed forces and moved to provide military assistance to keep the Kabul-Hairaton Highway open to supply Afghanistan. The Politburo also sent a military mission, headed by Minister of Defense Dmitri Yazov to Kabul to determine the needs of the Afghan Armed Forces. GOSPLAN, the Ministry of Finances, and the Ministry of Foreign Affairs were to engage the Afghan counterparts in determining the level of aid that would be required to sustain the DRA.<sup>26</sup>

As a result of General Yazov's visit, General Gareev found himself on a plane for Kabul to head the Soviet Military Advisor Mission.<sup>27</sup>

The Soviet Military Mission worked directly with the Afghan Ministry of Defense and the General Staff. Gareev enjoyed direct access to President Najibullah and used that connection at times to by-pass both the Ministry and the General Staff. The Military Mission was subordinated to the Soviet Ministry of Defense but kept close liaison with the Ministry of Foreign Affairs and the KGB through the Ambassador and Station Chief. Gareev had infrequent direct communications with General Secretary and later President Gorbachev and more frequent communications with Foreign Minister Shevardnadze and Chairman of the KGB Kriuchkov. Such communications were conducted by secure telephones "VCH" and encrypted cable traffic.<sup>28</sup> His portrait of the working relations among the higher echelons of command within the Soviet and Afghan MODs and Armed Forces presents a picture of bureaucratic inertia and an unwillingness to take responsibility for anything but routine affairs.<sup>29</sup> Personal connections were critical to overcoming such inertia. In the case of Afghan senior commanders relations were often colored by political rivalries. Gareev headed an advisory mission that numbered about 300 persons.<sup>30</sup> The leadership was composed of 30 military specialists, general officers and colonels with tactical operational expertise and knowledge of Afghanistan. Many of these officers had served extensively in Afghanistan and had intimate knowledge of the peoples and the culture.<sup>31</sup> Finally, the mission also had to deal with a new feature of in Soviet life, glasnost', and this meant handling relations with a press that was just finding its role as an independent voice. Whereas in the past, Soviet officers could respond to all questions with the answer that the matter involved military secrets, the mission had to deal with a steady stream of rumors often the results of leaks within the government or disinformation from the various mujahadeen factions.<sup>32</sup>

On its arrival, the mission had to address the immediate concern of the regime, which was to stave off the fall of its capital, Kabul, into enemy hands. Gareev was tasked with advising the Afghan High Command to ensure the external defense of the capital from Mujahadeen attack. The political-military assessment by the Afghan regime and its Soviet advisors was that the insurgents would combine an attempt to storm the capital and with an internal uprising a fifth column with the city and the defections of military units to achieve their objective. What Gareev observed was a defensive posture designed to protect the personal security of the President but no integrated defense. The Ministry of State Security directed the diverse elements of the capital's forces – secret police, national guard, and tribal formations and had no formal relationship with the Ministry of Internal Affairs, the Ministry of Defense or the Afghan General Staff.<sup>33</sup> After many, long, and intense

sessions, the President approved a plan of defense involving three defensive belts and integrating the forces of the Ministry of State Security, Ministry of Internal Affairs, and Ministry of Defense under the direct command to the Deputy Chief of the High Command, Vice President General M. Rafi, with the staff of the garrison coordinating the defense.<sup>34</sup>

The Ministry of Defense's forces conducted the defense of the north half, while the forces of the Ministry of Internal Affairs and Ministry of State Security conducted the defense of the west-south west and south and south east. Completing work on organizing the defensive positions of the capital, the Afghan high command moved towards relieving the capital's exposed position by active measures a limited ground offensive against Mujahadeen positions to the northwest of the capital at Paghman about 20 kilometers from the outskirts of Kabul. In the course of the Soviet intervention, Paghman had been turned into a strong defensive position, supply base, and firing point for rocket attacks upon the city. The offensive measures were designed to destroy the defending force, capture the supply base and remove the firing positions. The last point encompassed both military and political goals. The military objective was to remove the threat of artillery and rocket fire disrupting the air LOCs between Kabul and the Soviet Union, and the political rationale was to end the impression of the powerlessness of the government to protect the civil population from attack. This was a major source of popular discontent and regime vulnerability. Garrison forces mounted a two-phase offensive operation against Paghman. In early May government forces surrounded the area and cut it off from external support. In the final phase in late June these forces stormed Paghman using their artillery to smash the resistance's strong points. This success, however, was in part a result of the Mujahadeen's decision to strike their main blow elsewhere.<sup>35</sup> Securing the defense of the capital put the regime in a stronger military and political position to deal with the Mujahadeen's summer offensive.

In March 1989, the Mujahadeen focused their offensive efforts on the capture of Jalalabad. The occupation of this city in eastern Afghanistan was supposed to set the stage for the establishment of a mujahadeen government in the country and set the stage for the collapse of the DRA. To this objective the mujahadeen focused their attack upon the I corps, where there was discontent with the Najibullah government. The defection of elements of the 11th Division set in motion the mujahadeen advance on Jalalabad and opened the city to possible occupation. However, delays in the mujahadeen advance and the movement of reserves from Kabul stabilized the situation. Gareev describes in detail the battles within the government over whether to reinforce Jalalabad, especially the fight between those who wanted to keep forces in Kabul and those who saw the loss of Jalalabad as the beginning of the end for the army and the government. Gareev flew into the besieged city and

took part in the organization of its defense. He notes the sustained efforts made by the government to rush reserves and supplies to the city. Local Afghan commanders were certain that the appearance of a senior Soviet advisor was a sure sign that Soviet re-enforcements were on their way. Gareev had to disabuse the commanders of such false hopes and get them to understand that success in the field would depend upon their own efforts and that the defense of Jalalabad was critical to the defense of the country and the survival of the government. Plans for the counter-offensive to relieve Jalalabad were pushed forward under the greatest secrecy and depended upon a massive movement of supplies from the USSR to Kabul by air, and the transport of the supplies to Jalalabad by truck convoys under constant threat of attack. The counter-offensive operation at Jalalabad, which would be the first large-scale offensive by the DRA Army after the withdrawal of Soviet forces, involved significant military and political risks. Success depended on the fire suppression of the defense using artillery, air attacks, and rocket strikes, including SCUDs.<sup>36</sup> The counter-offensive proved successful and had two significant outcomes. The mujahadeen offensive for 1989 did not bring about the collapse of the DRA government, and both the DRA and its armed forces gained renewed confidence that they could survive without the intervention of Soviet ground forces. Soviet military assistance, especially the continued deliveries of ammunition and equipment, played a decisive role in the revived combat power of the DRA Army. A critical part of that success depended upon the regular delivery and surface to surface missiles of the “Smerch,” “Tochka,” and “Luna M” models. The Afghans were particularly concerned about ensuring the daily deliveries of 10-12 SCUD missiles to Kabul in order to sustain the volume of fire necessary to suppress the enemy on key axis. Najibullah also requested deliveries of aircraft and helicopters to replace losses during the year and supplies of food, fuel and essential goods for the urban centers and the troops.<sup>37</sup> Gorbachev replied that Soviet military assistance would be forthcoming but was intended to “persuade” the enemy and their foreign supporters that the only solution to the conflict in Afghanistan would come from intra-Afghan dialogue. In the meantime the USSR would deliver the arms requested, but warned that the Soviet Armed Forces were stripping their own arsenals to send Luna-M and SCUDs missiles and stated: “in this regard it is extremely desirable that the R-300 (SCUD) missiles being delivered be used in a rational manner.”<sup>38</sup>

In the end, a year after Gareev’s return to Moscow for health reasons, the Najibullah government collapsed. Weakened by the defections of the Minister of Defense Lt. Gen. Shahnawaz Tanai in March 1990—when a coup led by him and supported by some air force officers and some divisions of the army failed—the government turned increasingly to its political course to bring about a settlement of the conflict. This involved greater concessions to the opposition in order to



win over moderates and expedite the return of the exiled population to Afghanistan. The collapse, however, was complex in the extreme. The shifting nature of the Afghan oppositions was raising concerns in Washington about the advance of Islamic Fundamentalism and creating tensions in the Bush administration. Instability in Pakistan after the death of President Zia ul-Haq in 1988 led to a shift of government policy towards the insurgency after elections brought Benazir Bhutto to power as Prime Minister in late 1988. For the next twenty months, Pakistani policy moved away from supporting the most fundamentalist parts of the Afghan resistance until she was forced from office under charges of corruption in 1990. The architect of her removal, Nawaz Sharif, turned to Osama Bin Laden for financial support and through Bin Laden got access to Saudi money by declaring his love for jihad to a skeptical Bin Laden.<sup>39</sup> The Pakistani government once again renewed its assistance to the most radical Islamic elements of the Insurgency. Less than a year later Gorbachev's position in Moscow collapsed in the aftermath of the August Putsch and disintegration of the USSR. President Boris Yeltsin lost no time in ending support for Najibullah's government, cutting off military aid, food supplies, and fuel. The loss of external support emboldened the resistance which marched on Kabul. Najibullah was forced from power by his own party and Kabul fell to the insurgents in April 1992. The resistance never achieved sufficient unity to rule and chaos ensued, a chaos that the Taliban and al-Qaeda were willing and able to exploit.

The critical lessons of the Soviet military assistance to the DRA after the withdrawal of Soviet forces were that the aid did provide sufficient military strength to give the government a political opportunity for a successful political solution. This depended upon the abandonment of the goals of the April Revolution, a reversion to Afghan traditional politics of a weak center seeking to mediate among competing tribal and ethnic factions. Military power provided the stability through which political legitimacy and social reconstruction could begin. But the effort depended upon continued Soviet military and economic assistance and a relatively benign international environment that would give the experiment time. Such was not to be the case. The five lessons about making war in Afghanistan outlined by Maksim Usin, therefore, seem to apply to the post 1989 period of military assistance when there were no more infidels and the war went on.

## Endnotes

- 1 Ibid., p. 47.
- 2 On the negotiations leading to the Geneva Accords see: Diego Cordovez and Selig S. Harrison, *Out of Afghanistan: The Inside Story of the Soviet Withdrawal* (London: Oxford University Press, 1995).
- 3 Robert D. Kaplan, *Soldiers of God: with the Mujahidin in Afghanistan* (Boston, Mass.: Houghton Mifflin, 1990); Mark Galeotti, *Afghanistan, the Soviet Union's Last War* (London: Frank Cass, 1994); and Edgar O'Ballance, *Afghan Wars, 1839-1992: What Britain Gave Up and the Soviet Union Lost* (New York: Brassey's, 1993).
- 4 Stephen Blank, *Afghanistan and Beyond: Reflections on the Future of Warfare* (Carlisle Barracks, PA: Strategic Studies Institute, U.S. Army War College, 1993); and Mohammad V. Narwoz and Lester W. Grau, *The Soviet War in Afghanistan: History and Harbinger of Future War* (Ft. Leavenworth, KS: Foreign Military Studies Office, 1995).
- 5 Lester Grau, editor, *The Bear Went Over the Mountain*, 2nd edition (Ft. Leavenworth: Foreign Military Studies Office, 2005); Lester Grau and Ali A. Jalali, *The Other Side of the Mountain* (United States Marine Corps Studies, 1995); and Lester Grau and Michael A. Gress, *The Soviet-Afghan War: How a Super Power Fought and Lost* (Lawrence: University Press of Kansas, 2002).
- 6 Grau and Gress, *The Soviet-Afghan War*, p. 310.
- 7 Robert M. Cassidy, "Russia in Afghanistan and Chechnya: Military Strategic Culture and the Paradoxes of Asymmetric Conflict," (Carlisle Barracks, PA: US. Army War College, Strategic Studies Institute, 2003), <http://www.strategicstudiesinstitute.army.mil/pubs/display.cfm?pubID=125>, accessed 29 July 2006
- 8 Robert M. Cassidy, "Russia in Afghanistan and Chechnya: Military Strategic Culture and the Paradoxes of Asymmetric Conflict," (Carlisle Barracks, PA: US. Army War College, Strategic Studies Institute, 2003), <http://www.strategicstudiesinstitute.army.mil/pubs/display.cfm?pubID=125>, accessed 29 July 2006
- 9 Robert M. Cassidy, "The Long Small War: Indigenous Forces for Counterinsurgency," *Parameters*, (Summer 2006), p. 61.
- 10 See: James H. Willbanks, *Abandoning Vietnam: How America Left and South Vietnam Lost Its War* (Lawrence: University Press of Kansas. 2004), p. 56-58; and Robert K. Brigham, *ARVN: Life and Death of the South Vietnamese Army* (Lawrence: University Press of Kansas, 2006), pp. 1-26.
- 11 Boris Pastukhov, "Returning to the Lessons of the Afghan War," *Krasnaia zvezda*, (17 February 1999).
- 12 Makhmut Akhmetovich Gareev, *Moia posledniaia voina (Afganistan bez sovetskikh voisk)* (Moscow: INSAN, 1996); and M. A. Gareev, *Afganskaia strada, (S soevtskimi voiskamai i bez nikh)* (Moscow: INSAN, 1999).
- 13 Makhmut Gareev, "Voennoe stroitel'stvo: vzgliad na problemu lokal'nye voiny i podgotovka voisk," *Krasnaia zvezda* (20 November 1992); M. A. Gareev, *If War Comes Tomorrow: The Contours of Future Armed Conflicts* (London: Frank Cass, 1998); M. A. Gareev, "O nekotorykh kharakternykh chertakh vojn budushchego," *Voennaia mysl'* (June 2003), pp. 52-59; and Vladimir Slipchenko and Makhmut Gareev, *Budushchaia voina* (Moscow: Polit.ru OGI, 2005).

- 14 Maksim Iusin, "Pyat' urokov Afganistana: Opyt Rossiiskogo 'ogranichennogo kontingenta' mozhnet prigodit'sia amerikantsam," ["Five Lessons of Afghanistan: The Experience of the Russian 'Limited Contingent Can Serve the Americans"], *Izvestiia* (19 September 2001), p. 3.
- 15 Makhmut A. Gareev, *Afganskaia strada*
- 16 Ibid.
- 17 Ibid.
- 18 Ibid.
- 19 Ibid.
- 20 Ibid.
- 21 Alexander Golts, "Afghan Lessons for Russian General," *The Russian Journal* (25 January 2002), <http://dlib.eastview.com/sources/article.jsp?id=1907005>
- 22 The Soviet-Afghan War . . . , pp. 48-52.
- 23 Ibid., p. 332.
- 24 'Record of a Conversation of M. S. Gorbachev with President of Afghanistan, General Secretary of the CC PDPA Najibullah, 13 June 1988," in: Christian Friedrich Ostermann, "New Evidence on the War in Afghanistan," in *Cold War History Project Bulletin*, Issue 14/15, p. 185.
- 25 Aleksandr Kuchukov, "Cherez piat' vojn," *Krasnaia zvezda* (23 July 2003); and "Tubilei. Generalissimus voennoi nauki," *Nazvisimoe voennoe obozrenie* (25 July 2003).
- 26 A. A. Liakovsky, *Plamya afgana* (Moscow: ISKON, 1999), pp. 462-463.
- 27 Gareev, *Moia poslednaia voina* . . . , pp. 87-88.
- 28 Ibid., pp. 318-319.
- 29 Ibid., pp. 334-346.
- 30 Vladimir Georgiev, "Tajik Commandos in Afghanistan," *Nezavisimaia gazeta* (26 December 2001), p. 5.
- 31 Gareev, *Moia poslednaia voina*, pp. 348-350.
- 32 Ibid., pp. 350-354.
- 33 Gareev, *Afganskaia strada*, pp.186-188.
- 34 Ibid., p. 189.
- 35 Ibid., pp.193-194.
- 36 Gareev, *Moia poslednaia voina* . . . , pp.. 237-251.
- 37 Liakhovskiy, *Plamia Afgana*, pp. 524-525.
- 38 Ibid., pp. 525-526.
- 39 "Former Pakistani PM met Bin Laden Discussed Jihad – Says Ex Intelligence Agent," *Militant Islam Monitor*, (March 22, 2006), <http://www.militantislammonitor.org/article/id/1779>, accessed 9 August 2006.



## **US-Central Asian Security Cooperation: Misunderstandings, Miscommunications & Missed Opportunities**

**Mr. William C. Lambert—Command and General Staff College**

### **Introduction**

In a matter of only 14 years, US security relations with the countries of Central Asia went from nonexistent, to low-level, then quickly to front-line state status, and then, as in the case of Uzbekistan, just as rapidly back to low-levels (and nonexistent in some areas). An analysis of the overall US security cooperative in the region reveals that while many things were done right, other efforts and activities can best be characterized by misunderstandings, miscommunication & missed opportunities.

This paper is the first portion of a larger two part effort aimed at examining the wide array of security cooperation efforts in the region from both the US and host-nation perspectives with a view to identifying lessons learned. This portion of the work examines examples of misunderstandings, miscommunication and missed opportunities that negatively impacted on the achievement of US goals and objective in the region.<sup>1</sup> The second portion of the work examines some of the reasons why these misunderstandings, miscommunication & missed opportunities occurred and draws lessons learned that might preclude them from occurring again—in this region or elsewhere.

For the purpose of this discussion, security cooperation is expanded beyond the DOD definition of “All Department of Defense interactions with foreign defense establishments to build defense relationships that promote specific US security interests, develop allied and friendly military capabilities for self-defense and multinational operations, and provide US forces with peacetime and contingency access to a host nation” (JP 3-07.1). This paper considers *all US government interactions* with foreign defense and *other security establishments* aimed at the same purpose.

The views expressed in this work are those of the author and do not necessarily reflect the official policy or position of the U.S. Army Command and General Staff College, the Department of the Army, the Department of Defense, The Department of State, Department of Homeland Security or the U.S. Government. This report is cleared for public release; distribution is unlimited.

## Background

On 15 February 1989, Lieutenant General Boris V. Gromov, commander of the Soviet forces in Afghanistan, walked out of Afghanistan across the Friendship Bridge to the border city of Termez in Uzbekistan. It was 9 years and 50 days after Soviet troops intervened in Afghanistan. "There is not a single Soviet soldier or officer left behind me," General Gromov told a Soviet television reporter waiting on the bridge. "Our nine-year stay ends with this."<sup>2</sup> With that, the Soviet military effort in Afghanistan ended. The bridge had been built by the Soviet Army in 1982 to supply its force in Afghanistan. Less than 13 years after the Soviet departure, the bridge was once again used to resupply foreign forces conducting military operations in Afghanistan -- the US led Coalition fighting to remove the Taliban from power and dismantle its terrorist training centers.

By the end of 2002, security relationships with the Central Asia States (CAS) had reached levels previously unimaginable.<sup>3</sup> US and Coalition forces operated out of bases in Uzbekistan and Kyrgyzstan. Uzbekistan granted use of its former Soviet base at Karshi-Kanabad (K2) on 5 October 2001. The Kyrgyz Republic granted permission for Coalition forces to use the Manas international airport in its capital, Bishkek on 11 December 2001. The December 21, 2001, visit of Kazakhstan's President Nursultan Nazarbayev to Washington resulted in the signing of a number of bilateral documents and issuance of a Joint Statement of the two Presidents on the "New Kazakhstan-American Relationship", in which they confirmed their "commitment to strengthen the long-term strategic partnership and cooperation...".<sup>4</sup> Three months later, on March 12, 2002, Uzbekistan's President Islam Karimov visited Washington where he met with President Bush. During that visit, Secretary of State Colin Powell and his Uzbek counterpart Adulaziz Kamilov signed the "Declaration on the Strategic Partnership and Cooperation Framework between the United States of America and the Republic of Uzbekistan".<sup>5</sup> On September 23, 2002, President Bush hosted President Askar Akayev of the Kyrgyz Republic at the White House. The visit included the issuance of a joint statement declaring both parties' "commitment to strengthen the long-term, strategic partnership and cooperation between our nations...".<sup>6</sup> On December 9, 2002, President Imomali Rahmonov of Tajikistan paid a similar visit to the White House. Again, a joint statement was issued declaring "our commitment to continue the development of our long-term strategic partnership and cooperation between our nations...".<sup>7</sup> The mercurial Turkmen President Saparmurat Niyazov remained the only Central Asia leader without a White House visit and an accompanying joint declaration of strategic partnership.

Proponents, planners and implementers of various US security cooperation efforts in the region were overjoyed at the dividends their relatively low-cost efforts

had paid. The US had obtained access and basing rights in the geo-strategically important Central Asian region just eleven years after the breakup of the USSR. One CENTCOM after-action review was reported to state, “The investment in security cooperation has been repaid tenfold in access to basing, staging, and over-flight rights with regional partners.”<sup>8</sup> In his March 3, 2003, statement before a Defense Subcommittee hearing, Chairman of the Joint Chiefs of Staff General Richard Myers stated “One of the key lessons learned was the positive impact Theater Security Cooperation had on our operations in Afghanistan. It helped create the foundation that allowed our air, naval and ground forces to gain access to the region’s airspace and basing.”<sup>9</sup>

As it would turn out, much of this euphoria was short-lived as relationships in the Central Asian region quickly unravel over the next few years. This was especially true in the case of the US relationship with Uzbekistan, which had become a critical strategic partner in the war on terror. The region’s former Soviet-era leaders came under increasing scrutiny and criticism for the lack of progress, and in some cases outright reversals, in the areas of human rights, democratization and economic reforms. With the immediate need for basing, over-flights and other support satisfied, the voices of those pushing for greater reform became louder. US criticism of the Karimov government in Uzbekistan increased substantially beginning in 2003 and throughout 2004. Other players, namely Russia and China, themselves gravely concerned about the West’s growing presence and influence, seized on the opportunities afforded by the discourse and aggressively sought to further their own positions.

In September 2003, Russia signed a 15-year military basing accord with Kyrgyzstan providing access for two dozen Russian aircraft and several hundred troops to the Kant airfield, only a few miles away from the US facility at Manas. In 2005, there were repeated reports of China seeking access to bases in the region.

Events in Uzbekistan in the spring of 2005 brought the already severely strained US-Uzbek relationship to the breaking point. On 13 May 2005, Uzbekistani troops opened fire on demonstrators in the town of Andijon. Reports of those killed varied significantly from 150 to over 500 killed. Credible sources put the death toll in the hundreds. The Uzbek government itself announced that its forces had killed 94 “terrorists.”<sup>10</sup> US officials, initially slow to respond, finally joined an international chorus calling for an independent investigation.

On July 5, 2005, the presidents of Uzbekistan, Kyrgyzstan, and Tajikistan joined the presidents of Kazakhstan, China, and Russia in signing a declaration

issued during a meeting of the Shanghai Cooperation Organization (SCO).<sup>11</sup> One portion of the declaration stated:

“Considering the completion of the active military stage of antiterrorist operation in Afghanistan, the member states of the Shanghai Cooperation Organization consider it necessary, that respective members of the antiterrorist coalition set a final time line for their temporary use of the above-mentioned objects of infrastructure and stay of their military contingents on the territories of the SCO member states.”<sup>12</sup>

There were reports that President Karimov insisted on the specific language used. While none of the Central Asia’s took immediate action to oust US and Coalition forces, the declaration signaled a significant change in the balance of influence in the region.

Many Uzbek citizens fleeing the fighting in Andijon crossed the border into neighboring Kyrgyzstan. International human right groups and several governments expressed concerns over the safety of these refugees should they return to Uzbekistan. On July 29, 2005, 439 people of these refugees were airlifted to Romania. Tashkent responded immediately. On the same day the refugees were airlifted, Uzbek officials announced the termination of the agreement permitting US forces to operate out of K2, giving the US six months to vacate. On 21 November 2005, the last US forces departed the base.

On April 19, 2006, recently elected Kyrgyz President Kurmanbek Bakiyev threatened to close the Coalition airbase at Manas, unless the US agreed to a new base leasing arrangement by June 1. Bakiyev reportedly requested that lease payments be increased to more than \$200 million per year up from the reported \$2 million per year under the current arrangement. He also reportedly re-affirmed Russia’s free use of its nearby base at the same time.<sup>13</sup> The pronouncement came on the eve of his visit to Moscow.

### **Misunderstandings**

Misunderstanding is defined as the failure to understand or to interpret correctly. The US-Central Asian security cooperation relationship has been marked by significant instances of misunderstanding -- on both sides.

### Definition of Security

Perhaps one the greatest misunderstanding from the beginning of the relationship was how each side defined security. Those in the US tended to define security



as: 1) Measures taken by a military unit, activity, or installation to protect itself against all acts designed to, or which may, impair its effectiveness; and 2) A condition that results from the establishment and maintenance of protective measures that ensure a state of inviolability from hostile acts or influences. (JP 1-02) The US looked at security from the perspective of ensuring stability in the region, assisting in the legitimate self-defense capabilities of the region's countries and a modicum of interoperability with and among the regions' militaries. Unfortunately, the ex-Soviet party leaders heading the newly independent states viewed security largely through the lens of regime preservation – staying in power at all cost. Threats to their regimes were poised more from internal forces, many reformist in nature, than from outside. This substantial difference in starting positions resulted in both sides often working cross-purposes.

#### Competition, Animosity and CENTRASBAT<sup>14</sup>

From the beginning, US military planners failed to understand the extent of competition and often deep-seated animosity between some of the Central Asian countries, especially between Uzbekistan and Kazakhstan. This failure led to the US promotion of a number of regional efforts that were doomed from the start. Most notable of these efforts was the “Central Asian Battalion”—CENTRASBAT – the highly visible and publicized centerpiece of early US security cooperation in the region. The initiative was based on the highly successful Baltic Battalion (BALTBAT—Estonian, Latvian and Lithuanian).<sup>15</sup> CENTRASBAT, proposed by the presidents of the three participating countries, was quickly supported by then Secretary of Defense William Perry. The US Atlantic Command (USACOM) was made the lead DOD organization charged with overseeing establishment, support and training of the peacekeeping battalion comprised of one company each from Kazakhstan, Uzbekistan, and Kyrgyzstan. Plans called for a multinational battalion staff. The commander of the unit would rotate between the three countries on a periodic basis. The effort included the establishment of a largely US-funded “In-the-Spirit-of” (ISO) Partnership-for-Peace (PfP) series of exercises of the same name. The first exercise occurred in July 1997 in Kazakhstan and Uzbekistan and was met with tremendous fanfare. The ambitious exercise saw a battalion from the 82d Airborne Division and a composite platoon of 40 Central Asia participants fly 6,700 miles nonstop from Pope AFB, North Carolina and jump into Kazakhstan in the longest airborne operation in history.

Despite high-level proclamations about the success of the '97 exercise, the battalion itself was doomed. Unlike their BALTBAT counterparts, relationships between the Central Asian participants were so strained that few agreements could be reached without the direct and constant prodding of US planners. The location

of the battalion became extremely contentious. The Kazakhstani and Kyrgyzstanis argued to locate the unit in Shymkent, Kazakhstan, just an hour north of the Uzbek-Kazakh border and Tashkent. Uzbek planners offered a location in Uzbekistan, privately expressing concerns about the Kazakhs permitting Russians access to the base for the purposes of spying on Uzbekistan.<sup>16</sup> Many other disagreements arose. Kyrgyzstani planner regularly sided with their Kazakh counterparts, further infuriating and entrenching the Uzbeks. But all participants continued to support the battalion, at least publicly in the face of constant and high-level US pressure. They all understood that the battalion was a means to garner US provided equipment and much needed training. In 1998, the exercise site shifted to Uzbekistan and Kyrgyzstan.

During an early planning conference for the 1998 exercise, Kazakh planners approached the ACOM planners and suggested an airborne operation be conducted as part of the upcoming exercise. The Kyrgyz endorsed the proposal. The Uzbeks objected. After considerable discussion, a collective decision was made not to conduct the drop. At least it appeared to be a collective decision.

The opening ceremony in Kyrgyzstan took place on September 26, 1998. In an effort to demonstrate USCENTCOM's commitment to its new area of responsibility (effective October 1, 1998), exercise planners arranged to have General Zinni, USCENTCOM Commander, present at the opening ceremony. He would then proceed onward with visits to the other countries (less Tajikistan). Seated next to Admiral Gammon, the USACOM Commander, Zinni and others watched the opening ceremony consisting of an elaborate and carefully choreographed mock battle. Several minutes into the action, the main Kyrgyz planner, Brigadier General Isakov (now Minister of Defense) announced that Kazakhstan, in a show of support to its smaller neighbor, was providing vital assistance. At that moment, a Kazakh IL-76 flew into the exercise area over a neighboring hill and Kazakh paratroopers began dropping into the middle of the exercise area. On landing, they formed up and marched in the ensuing parade of exercise participants. The Uzbek Minister of Defense was furious. The ACOM planners were completely caught by surprise. The airdrop that all had agreed was not going to be conducted had just occurred. Any future for CENTRASBAT ended that day.

Several days later while visiting Almaty, General Zinni asked Kazakh Minister of Defense Altynbayev why the airborne drop had been conducted. Altynbayev responded that he felt the exercise needed something new. When Zinni pointed out that the previous year's exercise included an airborne drop, Altynbayev stated that the airborne drop just conducted was not actually part of the CENTRASBAT exercise. Later in Tashkent, General Zinni discussed the exercise with Uzbek Minister

of Defense Tursunov who angrily stated “When I see a Kazakh, I see a Russian, and when I see a [Kyrgyzstani], I see a weak Kazakh.” The depth of the animosity between the countries was made very clear. To make matters worse, Tursunov firmly believed that the USCOM planners must have known about the airborne drop all along and had approved its conduct despite Uzbek objections. General Zinni and others did their best to convince Tursunov otherwise but the damage was done and Tursunov became increasingly difficult to work with during the rest of his tenure as MOD.

The competition between the Uzbeks and Kazakhs continued unabated. Every opportunity to show up the other was seized. In May 1999, General Zinni again visited the region. His visit to Almaty coincided with the US sponsored International Workshop for Earthquake Response (IWER), a multinational emergency response exercise.<sup>17</sup> During his visit to the exercise, the participants conducted an impressive demonstration of search and rescue, patient evacuations and fire-fighting skills. During the midst of gas explosions, fires, rappelling first responders and various other activities, the Uzbek contingent somehow managed to unfurl a one-story tall Uzbek flag several floors up between the two affected building -- in front of General Zinni, other distinguished visitors, and the rolling news cameras.

#### Power and Influence of Reformists

It seems clear that many Central Asian officials and Karimov especially, misunderstood and greatly underestimated the influence of those within the US government and the international community calling for reforms and advancement in the areas of human rights, democratization and economic reforms. Many mistakenly believed, particularly post 9-11, that US security concerns and the accompanying requirements for basing, overflights and other support, would serve to stave off criticism for lack of progress in other areas. There are many possible reasons for these miscalculations. One may be the often mixed signals the regions’ governments received from various agencies within the US government. The signals being delivered from the Department of State and the Department of Defense seemed often at odds. Karimov and others incorrectly believed that the supportive DOD voices would ensure his importance as a strategic partner in the Global War on Terror would outweigh the lack on progress on the other fronts.

#### Russian Influence

Many in the US failed to understand the extent of Russian influence in the region. Following the dissolution of the Soviet Union, some in Washington contended that the Central Asian’s eagerness to develop security cooperative relationships

with the US and NATO was evidence of waning Russian influence. Those that couched US-Russian influence in Central Asia in terms of a zero-sum game were delighted with early US security cooperative successes. Believing that “what’s good for the US is bad for Russian and vice versa,” these same officials confirmed their beliefs in the face of often open and vocal anti-Russian rhetoric coming out of the region. Tashkent in particular seemed extremely eager to turn its back on Russia for a new western oriented security relationship. In the end, it was the Russians who played the more successful zero-sum game, particularly in terms of Uzbekistan. The game continues elsewhere in the region.

Lower level interactions often seemed to confirm Russia’s loss of influence. Many Central Asia military officers appeared to take considerable pleasure in flaunting their new security association with the US in the face of Russian officers. On numerous occasions, CENTRASBAT Central Asian planners seemed to go out of their way to summarily dismiss Russian exercise planners’ requests at planning conferences, often in less than diplomatic fashion. While US planners always and properly played peacekeeper during these conferences, many seemed to share the Central Asians happiness over the reversal of fortunes in the region.

While publicly supportive of the CENTRASBAT exercise series, in private, many Russians did little to hide their hostility toward the “uppity” Central Asians or their distrust of US intentions.<sup>18</sup> The idea of US military forces entering into close security relationship with Central Asians, and the executing of a combat airborne jump into Kazakhstan did not sit well with many Russian officials. The public statements of some US officials did little to allay Russian concerns. Other statements seemed intended to serve notice to the Russians. On September 15, 1997, shortly after landing on the jump zone as the first person jumping into the CENTRASBAT exercise area, USMC General John (J.J.) Sheehan, then USA-COM Commander, stated “there is no nation on the face of the earth where we can’t go.”<sup>19</sup> The statement infuriated many Russians.

The attacks of 9-11 substantially changed US presence in Central Asia. The swiftness and depth of US penetration into the region appears to have caught Moscow off guard and without a plan to respond. Vitaly Ponomaryov, an expert with the Panorama Information and Expert Group, an independent think tank, said “The Sept. 11 crisis brought regional changes that Russia was unprepared for,” adding, “Uzbekistan has long been straining at the Moscow leash, and jumped at the chance to invite the Americans in.” Initial Russian responses were mixed. President Putin was quick to immediately condemn the attacks, offer his country’s condolences and pledge his support in the fight against terrorism. However, on September 14, as speculation grew quickly of the possibility of the Central Asian states playing

a prominent role in an expected US response, Russian Defense Minister Sergei Ivanov stated he did not see “even the hypothetical possibility of NATO military operations on the territory of Central Asian nations that belong to the Commonwealth of Independent States.”<sup>20</sup> The day following his September 23rd telephone call with President Bush, Putin said in a televised speech:

“Russia is supplying and intends to continue to supply all the information we have about the infrastructure and the location of international terrorists and their training bases. Second, we are ready to offer Russian airspace for airplanes with humanitarian aid for the region where the antiterrorist action will be carried out. Third, we have agreed on this position with our allies, including Central Asian states.”<sup>21</sup>

Reaction and interpretation of Putin’s remarks differed extensively. Some saw the speech as Putin’s permission for the US to establish bases in Central Asia. Oksana Antonenko, a Russian expert at London’s International Institute for Strategic Studies, stated:

“For the first time, he [Putin] actually explicitly stated that some Central Asian countries may decide on their own to allow the United States-led Coalition forces to use their air bases. And I think that this is really quite a big difference from what was previously stated by Defense Minister Ivanov, who said even hypothetically there cannot be a possibility that any Western countries can station their forces on any bases.”<sup>22</sup>

Dr. Pavel E. Felgenhauer, an independent Moscow-based defense analyst, saw things very differently, viewing Putin’s remarks as a clear setback for US military planners. He stated that he felt Putin had made “a clear statement that the United States military is not welcome in Central Asia, and that Russia will do its best to prevent any American military presence in the area.”<sup>23</sup>

On September 24, President Bush, responding to a question about Russian cooperation, said:

“I had ... an hour-long discussion with President Putin on Saturday. He was very forthcoming in his willingness to work closely with the United States in our efforts to battle terrorism... I found him to be a person who -- first of all, understands the vision that we’ve entered into a new conflict in the 21st century. Vladimir Putin clearly understands that the Cold War is over, and that the United States and Russia can cooperate. We can cooperate with a new strategic arrangement. We can cooperate in the battle against terrorism. We talked about a

lot of areas of the world. We talked about the Central Asian republics. And as you know, they have been forthcoming in their statements about their understanding of a potential campaign. And I told him I appreciated his willingness to work with us in that area.”<sup>24</sup>

On October 5, 2001, Uzbekistan granted use of the former Soviet base at Karshi-Khanabad (K2). On December 7, 2001, while enroute to the region and Moscow, then Secretary of State Colin Powell addressed US-Russian relations, stating:

“When you think... about the sensitivity of those southern “Stans” to the Russians and to us, many of my early conversations with Foreign Minister Ivanov and others, they had concerns about the south, terrorism, drugs, trafficking, smuggling, and to think that since the 11th of September we have been able to talk so openly with them and with the Russians in a way that says we can have a better relationship with these countries without causing the Russians to be concerned about it, and we talk openly about these things now. We also talked about, Mr. Ivanov and I talked about the Russians coming into Afghanistan, and here (inaudible) about it a little bit, because suddenly they were there one day, and two phone calls cleared it all up, and that’s the kind of transparency that exists in the relationship now between me and Igor, Don and Sergei, Condi and Vladimir Rushaylo, the President and Putin, so that these things don’t spin out of control because of a little bit of confusion.”<sup>25</sup>

On December 11, Kyrgyzstan granting permission for Coalition forces to use the Manas international airport in its capital, Bishkek. Many in Washington truly believed the Russians fully supported US efforts in the region. Despite the US administration’s optimistic assessment about the health of the US-Russian relationship, there were those in Moscow that openly questioned the US presence and intentions. Sergei Kazyonov, an expert with the independent Institute of National Security Research in Moscow was quoted as saying “It looks as though the Americans are set to stay in Central Asia,” adding, “There is a growing feeling here that the US is using the tragedy of Sept. 11 not only to punish the terrorists, but also to extend its own influence.”<sup>26</sup>

By mid-2002, the situation in Afghanistan seemed to have stabilized, and US criticism of the various Central Asian governments’ lack of progress in the areas of human rights, democratization and economic reform provided an opening for Moscow, which took increasingly open and aggressive actions to counter US influence in the region. This was particularly true of Uzbekistan.

The Russians worked to undermine US influence and programs at all levels. In the spring of 2002, the US government offered Uzbekistan assistance in upgrading a significant numbers of their aging Soviet era MI-8 transport and MI-24 attack helicopters under a program entitled Export Control and Related Border Security (EXBS) Aviation/Interdiction Project (AIP). Upgrade and assistance was to include avionics, surveillance, and communications systems, providing of spare parts, consumables, flight simulators and training for pilots and maintenance crews. A Pre-Proposal Conference was conducted September 23 – 25, 2002 in Tashkent. Fourteen different vendors participated including companies from the US, Ukraine, Lithuania, France, South Africa, Israel and Russia. Also attending the conference were representatives from the Russian Moscow Mil Design Bureau. At one stage of the conference, Moscow Mil Design Bureau representatives lectured those assembled that no upgrades could be made to any Uzbek aircraft (or for that matter, any MI helicopter anywhere in the world) without the participation of their organization.<sup>27</sup> They concluded that if Moscow Mil Design Bureau was not involved, they would not certify the aircraft receiving the modifications as airworthy. US representatives explained that fair competition was integral to the US contracting process and it would not be acceptable to require all vendors to obtain an airworthiness certification from Russia at whatever price Russia demanded. The US experts maintained that other certification sources were available and indicated the final Request for Proposal (RFP) would continue to reflect that the successful bidder would be required to provide an airworthiness certification from any appropriate and recognized source, preferably, but not exclusively, the Moscow Mil Design Bureau.

A meeting was called with Uzbek Minister of Defense Kodir Gulomov to discuss the situation. Gulomov stated that even should Moscow Mil Design Bureau refuse to certify the modifications, the Uzbek would use the aircraft and that the project should continue. Over the next few weeks, the Embassy received reports that the Uzbek position was perhaps about to change. Subsequent private discussions with Uzbek MOD officials revealed that the Russians had threatened to cut off all concessional pricing for repair parts to Uzbekistan if the helicopter upgrades went forward without either Moscow Mil Design Bureau involvement or a Russian firm.<sup>28</sup> In a November 19 meeting with the US Ambassador, Minister Gulomov announced that the Ministry of Defense was no longer interested in extensive helicopter upgrades and formally requested the Embassy consider using the funds allocated instead for design and procurement of helicopter simulators. The Russians had effectively undermined what Washington had considered “one of the most urgent priorities for preventing illicit trafficking, enhancing border security and ensuring continued support to Operation Enduring Freedom.”<sup>29</sup>

The Russian continued to undermine US presence in the region and match it when possible. In September 2003, Russia signed a 15-year military basing accord with Kyrgyzstan providing access for two dozen Russian aircraft and several hundred troops to the Kant airfield, only a few miles away from the US facility at Manas.

Having served notice to the US to evict the K2 base, Karimov turned increasingly toward Russia. On November 14, 2005, prior to his departure for Moscow, President Karimov said “the resentful forces that have been told to leave the Khanabad airfield will not rest. They never tire of subversive activities. I would say their main goal is to discredit Uzbekistan’s independent policy, disrupt peace and stability in the country, and make Uzbekistan obey.”<sup>30</sup> Later that day, President’s Putin and Karimov signed an alliance treaty that included language stating that an attack on either country would be considered an act of “aggression” against both. The agreement also raised the possibility of Russian use of a military base in Uzbekistan. Of the agreement, Karimov stated “Today, we are reaching an unprecedented level in our relationship,” adding “I understand and we all understand in Uzbekistan that it is unprecedented that Russia signs such a partnership agreement with Uzbekistan.”<sup>31</sup> To many, the treaty signaled the return of Uzbekistan to the Russian camp and the end of any real security relationship with the US for the foreseeable future.

### Chinese Influence

Perhaps owing to the region’s history as former Soviet Socialist Republics, China’s influence in the Central Asian region, at least early on, was never fully understood or at best, down played. Like their Russian counterparts, Chinese officials looked on with great suspicion as US influence and access grew in the region during the 1990s. Many in Beijing viewed the US military presence as a threat to its own political and economic interests in the region. Some Chinese officials went to far as to contend that US efforts in the region were specifically aimed at preventing the spread of Chinese influence in the area.<sup>32</sup> Others said the presence of US forces not only constituted a potential threat, but was also a factor in regional instability.<sup>33</sup> Although perhaps not as dramatic or visible as Russia’s activities in the region, China’s influence in the region is considerable, particularly in the economic realm and the energy sector specifically.

China’s significant economic progress and accompanying need for energy resources has lead to its effort to diversify its energy resources and Central Asia is a logical area of interest.<sup>34</sup> In April 2004, Winston Lord, a former US ambassador to China said:



There's no question that both India and China have strong energy needs, and as their economies grow, they are consuming more and more energy... Central Asia, being where it is, physically, is obviously an attractive area for both countries. So it's a potential source. I know that China's working very hard in this...<sup>35</sup>

He added that China:

has become the world's second-largest energy importer after the United States. This is going to have implications, of course, for Central Asia, where they formed this Shanghai Cooperative Group with Russia and the various Central Asian countries, so they want to have influence there.<sup>36</sup>

Chinese ties with Kazakhstan deepened considerably when, during a May 2004 visit to China, Kazakhstan's President Nazarbayev signed an agreement to construct the 990-kilometer, US \$1 billion Atasu-Alashankou oil pipeline connecting western Kazakhstan with China.<sup>37</sup> The pipeline went into operation on December 15, 2005 with first deliveries of Kazakh oil to China to begin in mid-2006.

China also took advantage of the severely strained US-Uzbek relationship in the aftermath of the Andijon killings. In late May 2005, as the US and the West became increasingly vocal in their calls for an independent investigation of the incident, President Karimov paid an official visit to Beijing where he was warmly welcomed. Of Andijon, a Foreign Ministry spokesman said "About what happened in Uzbekistan recently, we think it's their internal affair, but we strongly support the government crackdown on separatists, terrorists, and extremists. We support Uzbekistan, together with other Central Asian countries, combining their efforts in order to maintain peace and development in Central Asia."<sup>38</sup>

More recently, the Chinese have attempted to expand their influence beyond economics into the security sphere. On May 31, 2005, the Chinese newspaper "Huanqiu Shibao" (Global Time) reported that China was examining the possibility of establishing a military presence in Kyrgyzstan. A Chinese official was quoted as saying "deployment of troops to southern Kyrgyzstan 'might possibly be beneficial' to fight against the three evils of terrorism, separatism, and extremism."<sup>39</sup> The Chinese government quickly denied the report.<sup>40</sup> According to other reports, the Chinese made "quiet, yet definite inquiries about gaining access to" the about to be vacated US facility at Karshi-Khanabad in Uzbekistan in July 2005.<sup>41</sup> The Chinese interest allegedly "galvanized Russian military policy in Central Asia" prompting Moscow to ensure that it would potentially have sole access to Uzbekistan's military facilities—the result being the aforementioned Russian-Uzbek treaty.<sup>42</sup>

### Shanghai Cooperation Organization (SCO)

Policy makers in Washington failed to understand the significance and potential impact of the SCO in the region. Few in Washington took notice or expressed concern when on April 26, 1996, the heads of states of Kazakhstan, the People's Republic of China, Kyrgyzstan, Russia and Tajikistan signed the "Treaty on Deepening Military Trust in Border Regions" in Shanghai, China. The group would become known as the "Shanghai Five." On January 9, 2001, then Ambassador at Large and Special Advisor to the Secretary of State for the NIS (1997-1991) Stephen R. Sestanovich was asked about the possibility of the US joining the Shanghai Five organization and what options the US had to fight against terrorism in the Central Asian states such as Uzbekistan and Kazakhstan and Afghanistan. He stated:

I'm not sure what the membership requirements for the Shanghai forum are. I assume that's something the new administration will have to discuss. I'm not aware that they're looking for new members. But it's certainly true that some of the issues that are discussed in that organization are also ones that we discuss with the states of the region, whether it's international terrorism, drug trafficking, for that matter more hopeful issues like economic cooperation, opportunities for investment, and so forth. So I would say that there is -- if not a membership in the organization, at least an awareness of the importance of those issues and an opportunity to cooperate on the most important of them. I think it's fair to say that over the past couple of years the states of this region have come to feel the need to provide for their security, and have found that need more acute. They are throughout the region seeking to modernize their military establishment, find ways of largely reducing the size of them and increasing the effectiveness, in order to be able to deal with the real problems that they face. And they have as a result of that turned to countries beyond the region and international organizations for assistance in that process, whether it's through the cooperation in the peacekeeping battalions that the Partnership for Peace has helped them with, or through consultations and assistance that we provide on security of borders. Security issues are going to loom larger in the relations to the states of this region over the next several years, and I am sure that the -- as they have already, they will continue to seek assistance from beyond the region in addressing those problems.<sup>43</sup>

Sestanovich's candid response was revealing for a number of reasons. As the Special Advisor to the Secretary of State for the NIS and one of this country's leading experts on Russia and the former Soviet Union, the Caucasus and Central Asia, he seemed, some four years after the Shanghai Five's formation, only slightly aware of the organization's purpose and relationship with the Central Asian states.

To most US officials, there seemed to be little reason to take particular note of the organization. It had accomplished little and seemed too pose no particular threat to US interests. And while Russia and China have long distrusted each other, on occasion, their individual national interests converge and they have shown they can work in concert. The US presence in Central Asia is one of the areas of convergent interests and the SCO rapidly became a vehicle to act collectively against the US.<sup>44</sup>

On June 15, 2001, President Karimov joined the other five presidents of the Shanghai Five in issuing the Declaration on the Establishment of the SCO. Once again, few in Washington took note. The stated purpose of the new grouping:

Strengthening mutual trust and good-neighborly relations among member states; promoting their effective cooperation in political affairs, economy and trade, scientific-technical, cultural, and educational spheres as well as in energy, transportation, tourism, and environment protection fields; joint safeguarding and presenting regional peace, security and stability; striving toward creation of democratic, just, reasonable new international political and economic order.<sup>45</sup>

In the intervening four years between Sestanovich's comments and Uzbekistan entrance into the enlarged organization, little had changed with respect to attention paid to the organization. On July 1, 2005, before the SCO meeting, Russia's and China's leaders met in Moscow to discuss their goals in Central Asia. One observer suggested:

The meeting signaled a shift toward greater cooperation between the two states, completely solved their long-standing border disputes from the legal perspective and laid the foundation for greater integration of their state-controlled oil companies and banking sectors. One reason that the atmosphere in the Kremlin was so unusually amiable was the perception that a shared threat loomed larger than their differences in policy goals; that threat was Washington's role in Central Asia.<sup>46</sup>

The July 5, 2005 SCO declaration calling for members to establish a final time line for the removal of foreign forces from their respective countries caught many in Washington by surprise. It certainly heightened awareness of the growing influence of the SCO, especially as a mechanism by which Russia and China could further their collective goal of undermining US influence in the region. On July 14, 2005, General Myers was asked by a reporter what he thought the SCO declaration. He stated "...I don't think the Shanghai memo or communique or whatever came out was particularly useful," adding "Looks to me like two very large coun-

tries were trying to bully some smaller countries. That's how I view it." Myers also said that the US has much to offer the Central Asian region adding "Security and stability in Central Asia is an important concept, and those who can bring security and stability ought to be welcome in Central Asia."<sup>47</sup> Two weeks later, on July 29 Uzbek officials announced the termination of the basing agreement.

On May 4, 2006, some 10 months later, Senators Brownback (R-KS), Hutchinson (R-TX), and Kyl (R-AZ) introduced Senate Bill 2749. Entitled the Silk Road Strategy Act of 2006; the bill was intended to "update the Silk Road Strategy Act of 1999 to modify targeting of assistance in order to support the economic and political independence of the countries of Central Asia and the South Caucasus in recognition of political and economic changes in these regions since enactment of the original legislation".<sup>48</sup> Section. 203 of the bill was entitled "Sense of Congress on Safeguarding of United States Interests in the Countries of Central Asia and the South Caucasus" and read:

(b) Conflict Resolution- It is the sense of Congress that the United States Government should engage in the following programs and activities designed to promote conflict resolution in Central Asia and the South Caucasus:

(2) Recognizing that China and Russia are neighbors and regional powers of Central Asia and, in the case of Russia, of the South Caucasus, and that those countries have in the past taken steps at odds with United States security interests, such as in the case of curbing the United States military presence in Uzbekistan, the continuation and expansion of a strategic dialogue with Russia and China, including United States participation as an observer in the Shanghai Cooperation Organization (SCO) for the purpose of promoting stability and security in the region.

Although "Sense of Congress" resolutions cannot make it into law, that portion of S. 2749 provided concerned US lawmakers an opportunity to enter into the congressional record, concerns over the conduct of Russian, China and the SCO in undermining US security interests in the region. The bill was referred to the Committee on Foreign Relations where it remains.

#### Internal Competition and Friction within Countries

Many US officials failed to understand the tremendous competition and often deep-seated animosity and distrust between different agencies within the same country. Owing to their efforts to ensure the preservation of their regimes and a deep-seated distrust of all but their closest confidants, many Central Asian leaders

use their internal security apparatus (either the National Security Service (SNB) or Ministry of the Interior (MVD) to ensure various ministries stay in line. It is not uncommon to find members of a internal security service serving as first deputies or in other high-level positions through government where they can monitor the actions of ministers and their staffs. This was especially true in ministries having regular contact with US officials or those of other western countries. Example of this practice abound. During most of his tenure, Uzbek MOD Gulomov's first deputy ministers was a senior SNB officer. Gulomov rarely meet with US officials without this officer being present. American Embassy personnel working security cooperation issues with the Uzbek MOD did so through the International Department, which reported to Gulomov through the same SNB officer.

Other security cooperation programs working with Uzbek security agencies experienced similar "oversight" situations. The EXBS program's dealings with the Uzbekistan Committee of Border Protection (KOGG) were conducted through the KOGG's Chief of International Relations Division, headed by an MVD Colonel. As that program grew substantially after 9-11, the program worked increasingly through a new First Deputy Minister – again an MVD general officer. Other countries employed similar arrangements to varying degrees. These practices directly hampered US security cooperative efforts. On one hand, it did make discussions and negotiations more difficult at times as the SNB officers rarely had experience in the fields in which they served. They were there to watch their fellow countrymen. Those best suited and most qualified to actually contribute to a successful security cooperative relationship were often wary of saying or doing anything that might sound or appear inappropriate in front of their internal security shadows.

As the US-Uzbek relationship soured, these arrangements had serious repercussions for those that had worked closest with US officials. President Karimov seemed to single out those officials with particular vengeance. On November 18, 2005, Karimov unexpectedly fired Defense Minister Kadir Gulomov. An MOD spokesman stated that Gulomov had been named advisor to Karimov on matters of education and science.<sup>49</sup> On May 17, 2006, reports surfaced that criminal charges had been brought against Gulomov and that he was to be tried by courts martial. No information was immediately available about the charges against Gulomov, although most observers believed the matter to be related to his close relations with US officials during tenure as MOD and that the charges had a undeniable undertones.<sup>50</sup> Subsequent reports indicted he had been charged with fraud, corruption, and abuse of office. On May 22, 2005, the trial began. It ended on July 14 with Gulomov being sentenced to five years imprisonment with the sentence suspended. The prosecution had demanded seven years in prison.<sup>51</sup> It seems clear

that Karimov perceived Gulomov, a fluent English-speaker and a highly polished and popular individual with US officials, as a threat.<sup>52</sup>

Harsh actions against those close to the US occurred at lower levels as well as in the case of Lieutenant Colonel Erkin Musayev. Musayev at one time headed the MOD's International Department. On June 16, 2006, Musayev was found guilty by an Uzbek Military Court of high treason, disclosure of Russian and Uzbek state secrets to American officials, fraud and criminal negligence. He was sentenced to 15 years in prison.<sup>53</sup> What is peculiar about Musayev's situation is that he retired from military service at the height of US-Uzbek relations and had been working for a UN agency in Tashkent for a number of years at the time the charges being brought.

These actions had a chilly effect on those working security cooperation actions with the Americans, not only in Uzbekistan but elsewhere in Central Asia. Given the similar "regime preservations" mentality of the other governments in the region, officials became increasingly wary of how their actions, as well intended and forthright as they may be, might be later misconstrued for some greater political purpose.<sup>54</sup>

Competition for resources and attention between different security agencies within the countries has undermined US security cooperation efforts. Several prominent examples come to mind. On February 14, 2000, amidst great fanfare, the first 12 of 16 FMS-provided High Mobility, Multi-Wheeled Vehicles (HMMWVs) arrived in Tashkent aboard a US Air Force C-5 cargo aircraft. The cost of the equipment and transportation amounted to \$2.65 million. The procurement of the HMMWVs and other US equipment had been a high priority of ,then, Uzbek MOD Tursunov. The procurement also represented the lion's share of Uzbekistan available FMF funding over a several year period, but Tursunov wanted the vehicles and the prestige it would bring to the Uzbek MOD. Unfortunately for Tursunov, no sooner than the vehicles drove off the aircraft, President Karimov directed the redistribution of the vehicles. Nine went to the KOGG, five to the NSS and only 2 remained with the MOD, the very organization that had expended a substantial portion of its available FMF for the vehicles. Tursunov was less than pleased. Over the next 24 months, repair parts and maintenance equipment for the vehicles were delivered.<sup>55</sup> Since the HMMWVs were originally intended for the MOD, all the parts and equipment were delivered to the MOD, where they stayed. The MOD refused to redistribute any of the parts or equipment to those agencies now possessing the HMMWVs. Consequently, many of the vehicles became non-operational. Efforts by Embassy personnel to intercede provided frustrating and large unsuccessful.

A major security cooperation objective in the region was to increase English-language proficiency within the region's security forces through the use of IMET-provided English language laboratories. Deliveries of these laboratories consisted of two parts, the first including the hardware itself, and the second consisting of teaching materials and software. A delivery of hardware to Kyrgyzstan's MOD went as planned and the equipment was installed in an MOD facility. Unfortunately, the second shipment of teaching materials and software was inadvertently delivered to the Kyrgyz National Guard. As the laboratories were of little use without those materials, the Embassy requested the National Guard turn over the materials to the MOD. They refused. After some time, the situation remained unresolved. The final solution included procuring an additional laboratory for the National Guard. The materials for that laboratory were then given to the MOD so they could put their lab into service. The inability and refusal of the two ministries to cooperate resulted in wasted time and resources.

### **Miscommunication**

Miscommunication is the failure to communicate clearly. Early US - Central Asian security cooperative efforts were marked by miscommunication. Miscommunication occurred between US officials and their Central Asian counterparts, between Central Asian agencies within the same country and between US agencies working security cooperation programs. Some of the early miscommunications were of the type that could reasonably be expected when countries, organizations and individuals unfamiliar with each other meet for the first time. From the US side, miscommunication with the Central Asians was often due to an over eagerness to make a good impression and to be supportive of the Central Asians. On many occasions, it was a matter of not properly managing Central Asian expectations. In other instances, the miscommunications resulted as a lack of understanding, poor staff work or worse.

#### Between US Officials & Central Asian Counterparts

During a July 1998 visit to Kazakhstan, the Arizona Adjutant General (TAG)<sup>56</sup> meet with Minister of Defense Altynbayev who provided the TAG and his entourage a very thorough briefing on his efforts to modernize his armed forces. During the brief, Altynbayev mentioned his desire to obtain US equipment, including jet fighters, airborne refueling tankers and armored vehicles through the Excess Defense Articles (EDA) program. At the conclusion of the brief, the TAG responded saying what an interesting brief it had been and that he would have his staff looking into how the Arizona National Guard might be able to assist. The TAG's response was not meant to imply that he either would or could assist with the EDA

issue. Unfortunately, by not specifically addressing that aspect of the discussion and perhaps informing the MOD that his organization had nothing to do with EDA, Altynbayev was left believing that the TAG had agreed to assist in this area. The miscommunication, as unintended and innocent as it was, would lead to embarrassment on the part of the US and frustration on the part of the Kazakhs.

In November 1998, some four months after the TAG visit, the Assistant Secretary of Defense (ASD), responsible for the region, visited Almaty and meet with Altynbayev. Several minutes into the discussion, Altynbayev surprised the ASD when he said “Why haven’t I heard anything from the TAG about the EDA equipment he said he’d provided.” The ASD was completely caught by surprise and it showed. Despite doing his best to extract himself from an uncomfortable position, the damage was done. Altynbayev was left with the impression that either the TAG had not done what it was Altynbayev thought he had agreed to do or that the many different DOD groups visiting Almaty did so without much coordination or real intent to assist. A lack of coordination among the many US visitors to the region was unfortunately all too true.

Other instances of miscommunication were not so innocent and generally resulted from US officials visiting the region who simply wanted to make an impression and perhaps inflate their own importance. These types of miscommunications not only served to undermine overall US efforts in the region, but tremendously complicated things for those working security cooperation programs.

In November 2002, a senior DOD official visited the region. During his visit to Tajikistan, he received a detailed briefing outlining the dire situation one of the Tajik security organizations found itself in with respect to basic equipment. Later that day, the DOD official was invited to a firing range as the guest of the head of that agency. Not surprisingly, a friendly marksmanship competition broke out. During the competition, the DOD officials said to the agency head “If you hit that target, I’ll get you those items you need.”<sup>57</sup> The minister hit the target and the DOD official turned to a uniformed officer accompanying him and instructed him to begin procurement of the items in questions. Unfortunately, the DOD official’s program had no authority to procure such equipment, resulting in a frustrating scramble to find a program that could so that funds could be offset to make good on the officials commitment.

A few days later, the same official visited Uzbekistan where he announced to Embassy officials that he was going to provide \$800,000 to a particular procurement project to offset a funding shortfall. Needless to say, Embassy officials were ecstatic. That afternoon, the DOD official meet with MOD Gulomov and proudly



announced that he was providing the \$800,000. Gulomov was delighted. Several days after the senior DOD official's departure from Uzbekistan, the Embassy was informed by his office that there was a problem. Just as in Tajikistan, the official had made a commitment for items that his program was not authorized to provide. Once again, the official's actions resulted in a mad scramble to reprogram funds from other programs to cover the official's unauthorized commitment.

In another instance, the visit of a US intelligence official to Tashkent prompted an agreement by several US agencies to work in concert to assist the Uzbeks with surveillance of their border in a particularly troubled area. At face value, the agreement seemed to make tremendous sense having the advantage of melding the best of what each of the agencies involved had to bring to the table to further US goals. A meeting was convened with all involved and the plan for cooperation was laid out to the Uzbeks. Equipment to be provided by one of the agencies was demonstrated. Examples of the types of mapping and imagery to be provided by the US intelligence agency were displayed. All departed the meeting with a real sense that a tremendous amount had been accomplished. Unfortunately, the visiting intelligence official was never heard from again. Repeated attempts to contact the individual through his agency's representatives in the Embassy failed. Ten months later, the cooperative effort was abandoned. Several officials mentioned that the individual in question had an established a pattern of similar promises and failure to deliver.

Such miscommunications, whether unintentional as in the case of the TAG visit, or of more dubious intent as in the latter three examples, seriously undermined US security cooperation efforts in the region.

#### Between Central Asian Agencies within the Same Country

Miscommunication also occurred regularly within the Central Asia counties between various national government agencies. One of the most frustrating and unfortunately pervasive legacies of the Soviet military ear imprinted on the new Central Asian security forces is the fear of informing higher ranking authorities of either bad news or opinions contrary to those of the higher authority. A prime example of this involved the Uzbeks and patrol boats for the Amu Darya River, which serves as the border between Uzbekistan and Afghanistan.

Early on during the emerging US-Uzbek security relationship, President Karimov made it clear he would appreciate assistance in modernizing the patrol craft used by the Uzbek Maritime Border Guards (KOGG) headquartered at Termez. He specifically stated that he desired new vessels. In response, the US dispatched sev-

eral assessment teams to survey the unit, its equipment and requirements with an emphasis on determining what type of new vessels would best suit the unit. In February 2001, a final assessment was conducted. The top priority and requirement cited by KOGG officials was the unit's ability to repair and maintain their present fleet of vessels. KOGG officials stated very emphatically, that given a choice, their preference was to refurbish the vessel they already had rather than obtaining new equipment. They emphasized that new vessels were neither needed nor desired. With that, the EXBS program began an aggressive program to provide KOGG the repair parts, equipment, materials and training needed to refurbish their vessels.<sup>58</sup> And the US government ended its efforts to provide new vessels

In April 2002, then, US Ambassador John Herbst visited Termez to view the US provided equipment and to see some of the recently refurbished vessels. Uzbek officials were profuse in their praise of the EXBS program, which had enabled them to refurbish much of their fleet. A short time later, during a meeting between Ambassador Herbst and President Karimov, the "new boat" issue was raised. Over one year after US officials had been lead to believe it had been laid to rest, Karimov asked what the status of the new boats was. Ambassador Herbst, believing that the issue had long been resolved, stated that he had recently sailed on one of the KOGG's newly refurbished vessels, making several points; that repairing of the existing fleet made more sense then new vessels; that the US assessments had recommended the same course of action; and that KOGG officials had expressed their interest to refurbish their current vessels rather than acquiring new vessels. Karimov responded stating that many of his people were not forward looking and that they did not fully understand the security environment, and concluded, insisting that new vessels were essential to Uzbekistan's security. Given the importance Uzbek support and the base at Karshi-Kanabad, procurement of new vessels for Uzbekistan became an immediate US objective. Subsequent discussions with KOGG and Uzbek government officials confirmed that no one in the government had raised the KOGG's stated desire to refurbish its fleet rather than procure new vessels to the President.<sup>59</sup>

#### Between US Agencies

Miscommunication between US agencies often impeded US security cooperative efforts. One of the conclusions arising from early border security assessments in Central Asia was the lack of adequate border surveillance capability throughout the region. Consequently, on the opening of the EXBS program in Uzbekistan in January 2001, one of the early areas of focus was the strengthening of the KOGG's border surveillance capability. This included studying the feasibility of building an aerial surveillance capability within the KOGG.<sup>60</sup> Uzbek KOGG officials quickly

agreed that such a capability was needed; however expected EXBS funding levels effectively eliminated any chance of furthering that effort. In the immediate aftermath of 9-11, additional funding for the region became available in the form of “supplementals” which seemed to provide the financial capacity to address what was considered a significant need. The Fall 2001 supplemental for Uzbekistan amounted to \$43 million. Of that, \$25 million was originally allocated for the MOD for procurement of Harris radios. The remaining \$18 million was earmarked for the KOGG with \$5.0 million of the \$ 18 million allocated to establishment of a rudimentary airborne surveillance capability within the KOGG.

The first prominent visit to Tashkent following 9-11 occurred on September, 28, 2001 with the visit of then Under Secretary of State for Arms Control and International Security Affairs, John R. Bolton. His visit was the first in a series of high level visits aimed at garnering Uzbek support for future operations in Afghanistan.<sup>61</sup> The \$43 million supplement was a significant “carrot” with which to entice the Uzbeks.

Unfortunately, those in Washington responsible for preparing Bolton’s talking points with the Uzbeks appear to have done a poor job of preparing them. As written, they indicated the purpose of the \$43 million funding for purposes other than intended. Bolton’s talking points clearly mentioned \$25 million for the MOD to procure Harris radios. The other \$18 million was described as \$5 million for use in upgrading Uzbekistan’s helicopters with the remaining \$13 million for border security assistance. No mention was made of the \$5 million being intended for the specific purpose of building an aviation surveillance capability within the KOGG. While the proper characterization of the funding was included elsewhere in Bolton’s briefing book, this information appears to have gone unnoticed.<sup>62</sup> Consequently, those in attendance came away thinking the \$5 million for helicopter upgrades was for the MOD, particularly given that it was the only Uzbek security agency with helicopters. Further, if \$5 million of the \$18 million being discussed was “obviously” for MOD helicopters, then the remaining \$13 million must also be intended for the MOD, despite that fact that they played only a back up role in the border security area. Sadly, the KOGG Chairman, whose agency was targeted for \$18 million of the \$43 million supplemental, was not invited.

On September 30, 2001, General Tommy Franks arrived in Tashkent. In a meeting that day, MOD Gulomov handed General Franks a letter which stated:

Dear Mr. General:

Allow me to express the gratitude for 43 million USD being granted to Ministry of Defense of the Republic of Uzbekistan by American party.

It is proposed to use the funds in the following way:

- 25 million USD shall be used to purchase tactical radio-communication equipment produced by American company "Harris" (list of equipment is attached).

- 18 million USD shall be used to implement the Program of modernization of avionics in helicopters supporting Special Forces of Republic of Uzbekistan.

Yours sincerely

Kodir Gulomov

General Franks, focusing squarely on securing Uzbek assistance and knowing little, if anything about the original intent of the supplemental and nothing of the \$18 million for the KOGG, not surprisingly agreed to support the request. General Franks subsequently discussed the letter and Gulomov's request with Secretary of Defense Rumsfeld who himself arrived in Tashkent a few days later on October 5, 2001. During discussions with Gulomov, Rumsfeld is reported to have supported the request as well.

The miscommunication set off a heated debate between two bureaus within the Department of State (NP and EUR), which ultimately resulted in a split memo being forwarded to then Deputy Secretary of State, Richard Armitage for decision. In April 2002, a compromise was finally reached which allocated \$14 million toward upgrades to MOD helicopters and the remaining \$4 million to "traditional" EXBS type activities and equipment. In the end, minimal upgrades were accomplished to the Uzbek helicopter fleet because of Russian interference. What had started as poor staff work in Foggy Bottom and resulted in a series of miscommunications in Tashkent, ultimately lead to the reallocation of funds originally intended to provide an aerial border surveillance capability to combat nuclear proliferation, to proving helicopter simulators for the Ministry of Defense.

### **Missed Opportunities**

An opportunity is defined as "a favorable juncture of circumstances or a good chance of advancement or progress." Missed is defined as to "failure to obtain." If security cooperation is defined as all US government interactions with foreign defense and other security establishments to build relationships that promote specific US security interests, develop allied and friendly military capabilities for self-defense and multinational operations, and provide US forces with peacetime and contingency access to a host nation, then it's clear that there have been many missed opportunities in US – Central Asian security cooperative efforts.

### Peacetime & Contingency Access

Some security analysts have chosen to downplay the loss of the Karshi-Khanabad base asserting that it was no longer needed or that the functions it served have been easily transferred to the Manas facility in Bishkek or elsewhere. Many of these same analysts assert that the US security cooperative effort worked flawlessly insisting that the US was able to gain critical contingency access to the region and facilities when most needed.

But these positions fail to address our ability to sustain that access and how we left as well as our future in the region. There is little chance that we're likely to be invited or permitted back in Uzbekistan should a real need arise for use of the now abandoned base and this coming after making significant improvements to the facility at considerable cost. Improvements included new housing units to replace tents, storage buildings, hard stands, and numerous quality of life facilities. Senior officials, when asked publicly about US long-term basing interests in the region repeatedly said the US was not interested in permanent bases. To many, the extensive upgrades to the K2 base suggested otherwise. When questioned about the extent of the upgrades, officials usually stated that the upgrades were actually quite minimal and intended only to ensure that, should the US ever need to reoccupy the base after its inevitable departure, that some minimum level of infrastructure would be present.

What is unfortunate about the entire situation is that it appears that the US could have easily locked up a long-term lease agreement at a very reasonable price. The Russian 15-year lease of the Kant base near Bishkek is often pointed to as an example. From the beginning, the Uzbeks pushed senior US officials for an official position with respect to what US long-term intentions were for K2. The issue was a constant theme in the Embassy's country orientation cables released prior to any senior officials' visit. And it was raised in virtually every meeting conducted between US and Uzbek officials.

In December 2003, the Uzbeks reportedly asked Washington to consider a new long-term agreement for the utilization of the base. Although specific reasons of this request are unknown, some analysts, including Central Asia-Caucasus Institute's John Daly, suggest that Karimov sought some confirmation of Washington's long-term security commitment to Uzbekistan in the wake of the Rose revolution in Georgia, which was said to unsettle Karimov.<sup>63</sup> He quotes one "well-placed" Uzbek as saying "We were prepared to sign a base agreement for five years, ten, or even fifteen. We needed and wanted clarity."<sup>64</sup> But Washington seemed content to push the matter off. Uzbekistan is said to have forwarded at least six letters to the Department of State during 2004 and the first six months of 2005 seeking clarifica-

tion of the base situation going so far as to include proposed draft agreements for discussion. The US reportedly failed to respond in any substantive way.<sup>65</sup>

The base access crisis in Kyrgyzstan appears to have been resolved, at least for the near future, but at a very significant cost. The US is said to be paying \$150 million a year for the base in addition to agreeing to provide four helicopters to Kyrgyzstan in the next year.<sup>66</sup> The previous year rent was said to cost some \$2 million a year. Although, less than the 200 percent increase originally demanded by Kyrgyzstan, it is still a very steep price, especially given that US officials had basically dismissed, out of hand, Uzbekistan's suggestion that they should receive any payment at all for the use of Karshi-Khanabad. Long term future use of the Mansa facility base remains uncertain. One can only expect that Kyrgyz will continue to feel significant pressure from Russia and China to eliminate the US presence in the region.

#### Develop Allied & Friendly Military Capabilities

Early security cooperative efforts in the region were limited in scope and relying very heavily on multinational programs such as the NATO Partnership-for-Peace (PfP) Program and its associated activities.<sup>67</sup> Those bilateral activities that were conducted usually consisted of low-level staff and unit exchanges designed to assist participants in getting to know one another better and to build a basis for further activities. More substantive activities were generally limited to PfP activities or bilateral activities tied directly to preparing for participation in PfP activities.

As discussed previously, CENTRASBAT was the centerpiece of early US security cooperation in the region. Considerable resources were allocated to the effort, unfortunately with little long-lasting or tangible results. The cost of pre-exercise training activities, planning conferences and the conduct of the inaugural CENTRASBAT '97 exercise was over \$5 million.<sup>68</sup> During a trip to the region in July 1998, RADM John Sigler, Director of Strategic Plans and Policy (J5), USCENTCOM, visited with the Uzbek contingent to the CENTRASBAT, an airborne company of over 100 soldiers. The unit commander was proud to inform Sigler that a significant portion of his unit had participated in the exercise. When asked for a show of hands of those who had participated, only two soldiers raised their hands. In the year since the exercise, the majority of the soldiers had left the service having completed their two-year conscription. With the exception of the two "veterans", the bulk of the unit consisted of newly inducted soldiers. A similar pattern was found to be true in the CENTRABAT companies in Kazakhstan and Kyrgyzstan. Significant resources had been expended and very little real capabil-

ity had been developed. When these findings were made known to OSD, and USCENTCOM officials were informed of that the real training value of the exercise was to the Central Asian officers involved in the exercise, as they tended to serve in the armed forces for longer periods of time. USCENTCOM suggested that there were more cost-effective ways to train officers.

In 1997, prior to assumption of responsibility for the training and equipping of the battalion and the associated exercise series, USCENTCOM planners suggested that the US work through the U.N. in an effort to identify and plan for a future operational peacekeeping deployment for the CENTRABAT, perhaps a few years down the road. The thought was that such a deployment might create a sense of urgency and purpose for the unit and the contributing countries. Senior DOD officials responded that there was no interest in ever actually deploying the CENTRASBAT. Rather, it was explained that the battalion and exercise series were seen strictly as a confidence building measure with which to engage the Central Asians. The opportunity to build a real capacity was lost on many in Washington.

#### The KAZBAT Success

After the tumultuous 1998 exercise, the CENTRASBAT slowly became less and less relevant. Within a few years, the battalion and the exercise series increasingly became viewed by the Central Asians as a US showpiece. But the Central Asians reluctantly went along in the face of US prodding. In spring of 1999, General Zinni again visited the region. During the trip, the Uzbek and Kazakh MODs were both forceful in expressing their respective desires to engage with the US on a bilateral basis as opposed to the multinational heavy approach that has been the case to that juncture. At one meeting, Kazakh MOD Altynbayev explained to Zinni that he was particularly interested in standing up a “KAZBAT”—a Kazakhstan national peacekeeping battalion. Altynbayev asked Zinni what he thought of the idea and Zinni responded that he felt that it was a good idea, adding that he and his command would support such a unit.

Following the meeting, an OSD observer approached a member of Zinni’s staff exclaiming, “General Zinni cannot do that! He cannot commit to supporting a Kazakh battalion! The policy is to support CENTRASBAT.”<sup>69</sup> The outburst was revealing for a number of reasons. The OSD staffer clearly did not understand the role of combatant commanders within their respective regions; nor the role of the OSD in such matters. It also illustrated a particular narrow mindedness and lack of forethought exhibited by many in Washington. If developing friendly military capabilities for self-defense and multinational operations were stated objectives of security cooperation, then a highly trained national Kazakh battalion made perfect

sense. Such a unit would represent a real capability rather than the hollow and empty promise of the CENTRASBAT. The OSD staff officer's objectives notwithstanding, USCENTCOM started working with the KAZBAT shortly thereafter. On January 31, 2000, President Nazarbayev signed a Presidential Decree officially establishing the KAZBAT.<sup>70</sup> In May 2003, Nazarbayev announced that Kazakhstan would send soldiers from the KAZBAT to Iraq in support of Coalition reconstruction efforts. As of August 2006, six contingents of KAZBAT soldiers have served in Iraq destroying mines and ordinance.<sup>71,72</sup> Had some in Washington had their way, the KAZBAT would never have come into existence.

### Building Relationships that Promote US Interests

Building relationships is never easy; it takes time, energy and action. Between 1997 and 2004, numerous opportunities presented themselves which could have served to deepen US – Central Asian relations. Many opportunities were fleeting. Unfortunately, many such opportunities were often missed, either through a failure to respond in a timely manner or through a failure to act at all. These instances caused many Central Asians to question the sincerity of US stated intentions.

The IMU incursion into Kyrgyzstan and Uzbekistan in 1999 and 2000 was such an opportunity. The incidents shocked the Central Asians and they looked desperately for outside assistance. Some of that assistance desired was in the form of lethal equipment, which the US refused to provide. Russia quickly stepped in and provided much of the requested equipment and material. The amount of equipment the Russians provided, was in fact, not that significant. However the fact that the Russians would provide it was not lost on those receiving the support. For many Central Asians, this created the expectations that true assistance of the type they really needed would likely only come from the north rather than the west.<sup>73</sup>

### Supplementals

In general, the Central Asian response to the events of 9-11 was quick and resolute. However several governments, Uzbekistan in particular, were very concerned about the prospects of the US moving into Afghanistan, eliminating the Taliban and then departing as rapidly as they entered, leaving Afghanistan's neighbors to deal with the turmoil and problems left behind. Karimov was particularly worried that his open support for the US would later serve as ammunition for those opposed to his regime; the IMU in particular. Some in the region pointed to the lack of US involvement in post-1989 Afghanistan as a harbinger of things to come. Assurances were made that this time things would be different; that the US was in it for the long haul.



To help sway Central Asia leaders, a series of supplemental funding packages were pushed through Congress. It was argued that substantial increases in funding for those supporting the US would demonstrate US resolve and appreciation, as well as bolster important US programs in the region. Privately, many Central Asians questioned how long this “appreciation” and support, and specifically heightened funding, would last. Many expressed concerns that as soon as things stabilized in Afghanistan, they would find themselves once again, at pre-conflict levels of assistance. As it turned out, these pessimists, or perhaps realists, were right.

Foreign assistance to Central Asia dropped substantially and rapidly after a one year significant increase as shown in the table below. Uzbekistan saw its assistance jump from a FY01 level of \$28,993,000 to \$160,405,000 in FY02, only to fall back to \$43,948,000 a year later in FY03. Uzbekistan was hit further when, in 2004 and 2005, the Secretary of State declined to make the determination required

Foreign Operations Budget Summary<sup>74</sup>

	FY 00 ACTUAL	FY 01 ACTUAL	FY 02 REQ	FY 02 ACTUAL	FY 03 REQ	FY 2003 ACTUAL	FY 04 REQ	FY 04 ACTUAL
Kazakhstan	\$50,208	\$51,159	\$51,543	\$57,867	\$51,560	\$51,296	\$41,530	\$41,867
Kyrgyzstan	\$32,648	\$36,353	\$32,004	\$84,652	\$43,604	\$46,316	\$50,273	\$43,529
Tajikistan	\$9,976	\$29,366	\$11,075	\$94,058	\$22,900	\$36,536	\$46,800	\$34,106
Turkmenistan	\$8,782	\$8,722	\$8,029	\$19,679	\$9,660	\$10,370	\$11,145	\$8,398
Uzbekistan	\$24,042	\$30,599	\$28,993	\$160,405	\$43,948	\$52,937	\$57,461	\$38,442
(\$ in thousands)								

in the Foreign Operations, Export Financing, and Related Programs Appropriations Act that Uzbekistan was making progress in meeting its commitments under the 2002 Strategic Partnership Framework. As a result, funding for some US military, border security, and economic reform assistance programs planned for the central Government of Uzbekistan was reprogrammed to other uses. Kyrgyzstan and Tajikistan also saw substantial increases, again only to see assistance levels drop to just slightly above FY01 levels.

These precipitous drops in funding led many Central Asians to seriously question the US commitment to the region. One can easily make a cogent argument that the increases were too much, too fast, and that a more prudent approach would have been to only double or triple levels of funding in the first year. Then maintain that level for another year or two to soften the inevitable downturn in assistance later. These huge increases were also extremely difficult for the countries, as well as those implementing agencies handling the programs receiving the increases, to handle and absorb. The EXBS program in Uzbekistan rose from \$3.25 million to over \$26 million in a matter of month without a corresponding increase in staffing

or outside assistance. Implementing agencies scramble to use the newly available funds. However in the rush to obligate funds as required, many decisions were rushed. In the end, the supplementals, as well intended as they were, seemed to cause as much problems as they solved. A more balanced and even multiyear approach would have been more effective.

Another example of a missed opportunity caused by a good idea being poorly executed was Coalition Support Funding (CSF). During a visit to Uzbekistan, General Franks announced that some \$15 million was being made available to Uzbekistan in appreciation for their support to the GWOT. They were informed that nothing was required on their part. Uzbek officials were obviously delighted. Unfortunately the truth changed. A short time later, it was decided (not by USCENTCOM but rather OSD) that the Uzbeks (and other receiving such funding) would be required to provide an accounting of what extra expenses their support of GWOT had generated in order to “qualify” for “reimbursement” under the CSF. This did not sit well with the Uzbeks and others as they had not asked for any such funding or reimbursement and they’d been informed no action was required. Over the next few months, considerable effort went into creating a sufficient justification to warrant “reimbursement” to the Uzbeks for the funding that had been promised to them with no strings attached. In the end, the funding was provided, but what had seemed like a good idea had only served to strain the relationship.

In other instances, US failure to take any action on legitimate Central Asian requests damaged the relationships. In December 2001, during the visit of Secretary of State Powell, President Karimov finally agreed to open the Friendship Bridge in Termez to humanitarian traffic. The US had been trying unsuccessfully to get the bridge opened since the beginning of operations in Afghanistan. The bridge was deemed critical to staving off a potential humanitarian crisis in Afghanistan. During negotiations on opening the bridge, the Uzbeks explained that their greatest concern about opening the bridge was its security. As such, they formally made a request to the US to provide surveillance equipment for the bridge itself, and the immediately surrounding area. Some additional command and control and communications equipment was also requested to assist in reopening the Border Guard and Customs facility at the bridge. The Embassy provide the assistance and agreed to examine the technical aspects of the issue. Numerous discussion ensued with various US agencies and the Uzbeks to determine technical requirements and how to best proceed. At one point, the RSO office dispatched an assessment team to examine the bridge and the Uzbek requirements. A detailed technical requirements and equipment list was produced. Two years later none of the equipment had been provided. Numerous efforts to procure the equipment in a timely manner were stymied by bureaucratic processes in Washington. Unfortunately, similar examples

abound where promised equipment and training had yet to be provided (or even procured) two or more years after having been formally offered to the Central Asians. These missed opportunities called many Central Asians to question US sincerity and intentions.

## **Conclusion**

US-Central Asian Security Cooperation can be characterized by misunderstandings, miscommunication and missed opportunities. Initially, many things were done right, or well enough, to ensure access to the region at a critical junction in the Global War on Terror. Unfortunately, the high levels of US-Central Asian security cooperation experienced in the immediate post 9-11 period proved unsustainable. The misunderstandings, miscommunication and missed opportunities discussed herein contributed to the United States inability to achieve some of the goals security cooperation was intended to address. In the end, only a portion of the stated US security and other interests in the region were achieved. Allied and friendly military capabilities for self-defense and multinational operations were only partially developed, well short of what many experts think was possible. And finally, the United States was unable to set the conditions to ensure future access in the region. Owing to the influence of Russia and China, whose influence the United States has failed to adequately address, the access we still enjoy remains very much in jeopardy. Many of the misunderstandings, miscommunication and missed opportunities addressed are only symptoms of great underlying problems in the way the United States conducts security cooperation. A future work will examine those underlying problems with a view to drawing lessons learned that might preclude them from occurring again—in this region or elsewhere.

## Endnotes

1 The author relies heavily on security cooperation in Uzbekistan where he served for 3 ½ years as the Export Control and Related Border Security Advisor to Uzbekistan.

2 Bill Keller, “Last Soviet Soldiers Leave Afghanistan,” *New York Times*, 16 February 1989. [On-line] Available from <http://partners.nytimes.com/library/world/africa/021689afghan-laden.html?Partner=PBS&RefId=Eutttt-uFBqv>; Internet: Accessed 8 July 2006.

3 According to then Assistant Secretary of Defense J. D. Crouch in testimony in June 2002, “our military relationships with each [Central Asian] nation have matured on a scale not imaginable prior to September 11th.” Crouch added that “for the foreseeable future, US defense and security cooperation in Central Asia must continue to support actions to deter or defeat terrorist threats” and to build effective armed forces under civilian control. Jim Nichol, “Central Asia: Regional Developments and Implications for US Interests.” *CRS Issue Brief for Congress*, 12 May 2006: 10. [on-line] available from <http://fpc.state.gov/documents/organization/67150.pdf>; Internet; accessed 8 July 2006.

4 The White House, “Joint Statement by President George W. Bush and President Nursultan Nazarbayev on the New Kazakhstan-American Relationship.” Office of the Press Secretary 21 December 2001, [on-line] available from <http://www.whitehouse.gov/news/releases/2001/12/20011221-10.html>; Internet; accessed 8 July 2006.

5 US Department of State, *Declaration on the Strategic Partnership and Cooperation Framework Between the United States of America and the Republic of Uzbekistan* [on-line] available from <http://www.state.gov/p/eur/rls/or/2002/11711.htm>; Internet; accessed 8 July 2006.

6 The White House, *Joint Statement by President George W. Bush and President Askar Akayev on the Relationship Between the United States of America and the Kyrgyz Republic*, 23 September 2002 [on-line] available from <http://www.whitehouse.gov/news/releases/2002/09/20020923-4.html>; Internet; accessed 8 July 2006.

7 The White House, *Joint Statement by President Bush and President Rahmonov on the Relationship Between the United States and the Republic of Tajikistan* 10 December 2002, [on-line] available from <http://www.whitehouse.gov/news/releases/2002/12/20021210-15.html>; Internet; accessed 8 July 2006.

8 GlobalSecurity.org *Operation Enduring Freedom—Afghanistan* [on-line] available from <http://www.globalsecurity.org/military/ops/enduring-freedom.htm>; Internet; accessed 8 July 2006.

9 US Congress. Senate. Committee on Appropriations. *Statement of General Richard Myers*, 5 March 2003 [on-line] available from <http://appropriations.senate.gov/hearings/record.cfm?id=203763>; Internet; accessed 8 July 2006.

10 A prosecutor in Uzbekistan’s Andijon Province set the official death toll from 12-13 May violence at 187—94 terrorists, 20 law-enforcement officials, 11 soldiers, 57 ordinary residents, and five unidentified individuals. *RFE/RL Central Asia Report*, “Week At A Glance (11-17 July),” Volume 5, Number 27, 21 July 2005 [on-line] available from <http://www.rferl.org/reports/centralasia/2005/07/27-210705.asp>; Internet; accessed 8 July 2006.

11 The Shanghai Cooperation Organization (SCO) is an intergovernmental interna-

tional organization founded in Shanghai on 15 June 2001 by six countries: China, Russia, Kazakhstan, Kyrgyzstan, Tajikistan and Uzbekistan. Its working languages are Chinese and Russian.

12 Shanghai Cooperation Organization, *Declaration of Heads of Member States of Shanghai Cooperation Organization* 5 July 2005 [on-line] available from <http://www.sectsco.org/html/00500.html>; Internet; accessed 8 July 2006.

13 Jim Nichol, "Central Asia: Regional Developments and Implications for US Interests." *CRS Issue Brief for Congress*, 12 May 2006: 12 [on-line] available from <http://fpc.state.gov/documents/organization/67150.pdf>; Internet; accessed 8 July 2006.

14 Also commonly referred to as CENTRAZBAT.

15 The formation of BALTBAT, a tri-national peacekeeping unit, commenced in late 1994. Today BALTBAT is a combined infantry battalion, capable of participating in peacekeeping operations and contributing to regional security. BALTBAT is based in Latvia. BALTBAT has had extensive experience in peace operations in the Balkans. Since 1998, a company of BALTBAT soldiers has participated in operations in Bosnia and Herzegovina. Ministry of Foreign Affairs of the Republic of Latvia, *Baltic Defence Co-operation—Main Joint Projects*, 16 September 2003 [on-line] available from <http://www.mfa.gov.lv/en/security/4494/4498/>; Internet; accessed 8 July 2006.

16 Based on author's discussions with senior Uzbekistan officials during the 1997-98 timeframe.

17 Later renamed the International Workshop for Emergency Response (IWER). Conducted under the National Guard Bureau's State Partnership Program SPP.

18 Observation based on author's attendance of 7 CENTRASBAT planning conferences and numerous discussions with Russian officers between July 1997 and May 2000.

19 The Jamestown Foundation, *The Fortnight in Review*, Volume 3, Issue 15, 26 September 1997 [on-line] available from [http://www.jamestown.org/publications\\_details.php?volume\\_id=4&&issue\\_id=220](http://www.jamestown.org/publications_details.php?volume_id=4&&issue_id=220); Internet; accessed 8 July 2006.

20 *RFE/RL*, "Russia: Defense Minister Says No Strikes From Central Asia," 14 September 2001 [on-line] available from <http://www.rferl.org/features/2001/09/14092001133747.asp>; Internet; accessed 8 July 2006.

21 Tony Wesolowsky, "Russia: Putin Offers Russian Cooperation—But How Much?," *RFE/RL*, 25 September 2001 [on-line] available from <http://www.rferl.org/features/2001/09/25092001124832.asp>; Internet; accessed 8 July 2006.

22 Ibid.

23 Ibid.

24 The White House, *President Freezes Terrorists' Assets*. Office of the Press Secretary, 24 September 2001, [on-line] available from <http://www.whitehouse.gov/news/releases/2001/09/20010924-4.html>; Internet; accessed 8 July 2006.

25 US Department of State, *Press Briefing on Board Plane En Route Tashkent, Uzbekistan*, 7 December 2001, [on-line] available from <http://www.state.gov/secretary/former/powell/remarks/2001/dec/6725.htm>; Internet; accessed 8 July 2006.

26 Fred Weir, "Russia Wary Of Postwar US Goals," *Christian Science Monitor*, 10 December 2001 [on-line] available from <http://www.csmonitor.com/2001/1210/p6s1-woeu.html>; Internet; accessed 8 July 2006.

27 One of the unique vestiges of the Soviet era is that existing arrangement between the

air forces of the Central Asia states and the Russian Federation—and the “Moscow Mil Design Bureau” specifically. The Moscow Mil Design Bureau provides air worthiness certification for all Uzbek Mi aircraft—not the Uzbeks themselves. The US Statement of Work for the upgrades stated that an airworthiness certification would be acceptable from any appropriate and recognized source.

28 In a May 20, 2002 discussion with Colonel Saydulla Madaminov, Commander of the Uzbek Air Force and other officer, the author was told that the Uzbek Air Force procured repairs parts through an Uzbek MOD to Russian MOD arrangement explaining that there was an existing agreement within the CIS under which Russia sells military equipment/repair parts to other CIS defense establishments as a substantially lower price than that charged by the Russian state-owned military export firm, Rosoboronexport (also seen referred to and spelled Rosvoorouzhenie). As an example, Madaminov claimed that while the Uzbek Air Force, as a defense establishment covered under the CIS agreement could procure an engine for an MI-8 for approximately \$45,000, that Rosoboronexport would charge \$128,000 for the same engine to a non-CIS country/firm—such as the US government.

29 US Customs Service, *Statement Of Work – Uzbekistan Aviation Assets: Aviation/ Interdiction Project Export Control And Border Security Program*, dated 24 July 2004.

30 Daniel Kimmage, “Uzbekistan: Between East And West,” *RFE/RL*, 17 November 2005 [on-line] available from <http://www.rferl.org/featuresarticle/2005/11/92A6AC50-57BC-45C3-AA47-AB431761F85D.html>; Internet; accessed 8 July 2006.

31 *RFE/RL*, “Putin, Karimov Sign ‘Unprecedented’ Alliance Treaty,” 14 November 2005 [on-line] available from <http://www.rferl.org/featuresarticle/2005/11/a3b8c0bf-b64e-4a6d-a8c4-10e792c13bf9.html>; Internet; accessed 8 July 2006.

32 Ibragim Alibekov, “Kazakhstan Under Pressure To Choose One Strategic Partner,” *Eurasia Insight*, 19 February 2002 [on-line] available from <http://www.eurasianet.org/departments/insight/articles/eav021902a.shtml>; Internet; accessed 8 July 2006.

33 Stephen Blank, “China Joins The Great Central Asian Base Race,” *Eurasia Insight*, 16 November 2005 [on-line] available from <http://www.eurasianet.org/departments/insight/articles/eav111605.shtml>; Internet; accessed 8 July 2006.

34 Nikola Krastev, “Central Asia: Strapped For Energy Resources, China And India Look For Alternatives,” *RFE/RL*, 22 April 2004 [on-line] available from <http://www.rferl.org/featuresarticle/2004/4/E62756BE-A943-41F1-B03E-86D920CB1188.html>; Internet; accessed 8 July 2006.

35 Ibid.

36 Ibid.

37 *Embassy of the Republic of Kazakhstan News Bulletin*, Vol. 1, No. 23 (20 May 2004) [on-line] available from <http://www.homestead.com/prosites-kazakhembus/052004.html>; Internet; accessed 8 July 2006.

38 Grant Podelco, “Uzbekistan: President Begins Visit To China Carrying No Baggage From Andijon Crackdown,” *RFE/RL*, 25 May 2005 [on-line] available from <http://www.rferl.org/featuresarticle/2005/5/8AEC6277-B0A6-450A-8E08-CBCE0B4688B2.html>; Internet; accessed 8 July 2006.

39 *RFE/RL Newslines*, Volume 9 Number 102, 31 May 2005 [on-line] available from

<http://www.rferl.org/newsline/2005/05/2-TCA/tca-310505.asp>; Internet; accessed 8 July 2006.

40 *RFE/RL Newslines*, Volume 9 Number 103, 1 June 2005 [on-line] available from <http://www.rferl.org/newsline/2005/06/2-TCA/tca-010605.asp>; Internet; accessed 8 July 2006.

41 Stephen Blank, "China Joins The Great Central Asian Base Race," *Eurasia Insight* 16 November 2005 [on-line] available from <http://www.eurasianet.org/departments/insight/articles/eav111605.shtml>; Internet; accessed 8 July 2006.

42 Ibid.

43 Stephen R. Sestanovich, "US Relations with Russian and the NIS," *Foreign Press Center Briefing*, 9 January 2001 [on-line] available from <http://fpc.state.gov/fpc/7459.htm>; Internet; accessed 8 July 2006.

44 Stephen Blank states that, dating back at least to 2004, high-ranking Russian officials have steadily underscored Moscow's steadfast opposition to a Chinese military presence in Central Asia. He states that, if anything, Russia may oppose a growing strategic role for China in the region more than it does the possibility of an extended American presence. For additional discussion see Stephen Blank. "China Joins The Great Central Asian Base Race," *Eurasia Insight*, 16 November 2005, [on-line] available from <http://www.eurasianet.org/departments/insight/articles/eav111605.shtml>; Internet; accessed 8 July 2006.

45 SCO, *Brief introduction to the Shanghai Cooperation Organisation*, [on-line] available from <http://www.sectsc.org/html/00026.html>; Internet; accessed 8 July 2006.

46 Adam Wolfe, "Cool-Headed Diplomacy," *Asia Times On-Line*, 6 August 2005, [on-line] available from [http://www.atimes.com/atimes/Central\\_Asia/GH06Ag02.html](http://www.atimes.com/atimes/Central_Asia/GH06Ag02.html); Internet; accessed 8 July 2006.

47 Central Asia - Caucasus Institute, "Myers Accuses Russia, China Of Bullying," *Central Asia - Caucasus Analyst*, 14 July 2005 [on-line] available from [http://www.caciana-lyst.org/view\\_article.php?articleid=3513&SMSESSION=NO](http://www.caciana-lyst.org/view_article.php?articleid=3513&SMSESSION=NO); Internet; accessed 8 July 2006.

48 GovTrack, *S. 2749: Silk Road Strategy Act of 2006*, [on-line] available from 2006 <http://www.govtrack.us/congress/bill.xpd?bill=s109-2749>; Internet; accessed 8 July 2006.

49 *RFE/RL*, "New Uzbek Defense Minister Named," 18 November 2005, [on-line] available from <http://www.rferl.org/featuresarticle/2005/11/BD182634-B2A8-403E-B2B7-DEAEE74880D8.html>; Internet; accessed 8 July 2006.

50 *Ferghana Information Service*, Ex-Defense Minister Of Uzbekistan Kadyr Gulyamov Is Under Examination, 17 May 2006, [on-line] available from <http://enews.ferghana.ru/article.php?id=1432>; Internet; accessed 8 July 2006.

51 *Ferghana News Agency*, "Ex-Defense Minister Of Uzbekistan Sentenced To Five Years Imprisonment (Sentence Suspended)," 17 July 2006, [on-line] available from <http://enews.ferghana.ru/article.php?id=1509>; Internet; accessed 18 July 2006.

52 Clan politics seems clearly behind this and other moves against Uzbek officials. Observers suggest that Karimov's moves are aimed at consolidating his hold on power by eliminating potential threats from opposing political clans. *RFE/RL*, "Uzbekistan: Karimov Appears To Have Political Clans Firmly In Hand," 31 August 2006, [on-line]

available from <http://www.rferl.org/featuresarticle/2006/8/970CDFCA-ADB7-4C9C-856B-526CEF00273B.html>; Internet; accessed 8 July 2006.

53 *Ferghana News Agency*, "Ex-Officer Of The Defense Ministry Of Uzbekistan Tried And Convicted For Treason Against The State," 16 June 2006, [On-line] Available from <http://enews.ferghana.ru/article.php?id=1479>; Internet; accessed 8 July 2006.

54 Several of my close Central Asian associates in the region report that the actions, particularly those against Musayev, who I'd worked with for over 7 years, have caused many to shy away from meaningful contacts with the West. Other have taken the unfortunate, albeit understandable measure of never meeting with US officials without other present "to vouch" for their actions.

55 A \$172,000 spare parts FMF case and a \$110,000 Tool/TMDE FMF case.

56 Arizona is partnered with Kazakhstan under the National Guard Bureau's State Partnership Program (SPP) with aligns the countries of the former Soviet Union and elsewhere with State National Guards.

57 Paraphrased based on discussion with several other present.

58 Initial deliveries under the EXBS program included 5 new diesel engines, 5 diesel 16-Kw generator for the Uzbek's PSKs (Pogranichnyi Storozhevoi Kater - medium sized patrol vessels), 60 tons of boat steel (for hull and superstructure repair), and a complete machine shop (including metal lathe, guillotine (steel plate cutting) machine, steel plate rolling machine, and 4 welding transformers). The border guards used their own funds and purchased a number of new engines as well as building new overhead facilities to protect the EXBS-provided equipment.

59 Two new vessel were eventually provided under the EXBS program. A contract was signed on June 23, 2003 on the amount of \$5.6 million for Ukrainian built "Gyurza" 25 meter patrol craft, designed specifically for use on the Amu Darya River. The vessels were delivered in January 2005.

60 The KOGG possesses no aviation assets. In the event aviation support is required, a request is made to the MOD for support by the Uzbek Air Forces which has fixed wing and helicopter assets. EXBS Advisor discussions with the KOGG Commander revealed that no MOD support had ever been rendered despite several requests for such support.

61 Within weeks of 9-11, high-level visitors descended on Central Asia in hopes of gaining support for US military plans against the Taliban. Particular attention was paid to Uzbekistan where the administration and DOD predicted the greatest chances of receiving required assistance. The first prominent visitor to Tashkent post 9-11 occurred on 28 September, with the visit of Under Secretary of State for Arms Control and International Security Affairs John R. Bolton. Two days later, General Tommy Franks arrived in town. On 2 Oct, Secretary of Defense Donald Rumsfeld ordered the preparation for deployment of US forces to Uzbekistan and Tajikistan departing later that day for Egypt, Saudi Arabia, Oman, and Uzbekistan. He arrived in Tashkent on 5 October. Following Rumsfeld's visit, Uzbekistan offered to allow US forces to conduct humanitarian and combat search-and-rescue missions from its bases. A reinforced battalion from the 10th Mountain Division arrived in Uzbekistan on 6 October. On October 7, US and British forces attacked Taliban military targets throughout Afghanistan.

62 The inconsistencies were discovered by the EXBS Advisor after being given access



to the reading book. Unfortunately Bolton had already concluded his discussions with Uzbek officials. Subsequent discussion with State officials indicate several key bureaus submitting papers for inclusion in Bolton's trip book were never afforded the opportunity to review the final talking points for accuracy.

63 John C.K. Daly, "Chronology of US-Uzbekistan Relations, 2001-2005," in *Anatomy of A Crisis: US-Uzbekistan Relations, 2001-2005*, John C. K. Daly and other, Central Asia-Caucasus Institute & Silk Road Studies Program, February 2006, pg 87.

64 Ibid., pg 87.

65 Ibid., pg 88.

66 Stephen Blank, "Beyond Afghanistan: The Future Of American Bases In Central Asia," *Central Asia - Caucasus Analyst*, 26 July 2006 [on-line] available from [http://www.cacianalyst.org/view\\_article.php?articleid=4349&SMSESSION=NO](http://www.cacianalyst.org/view_article.php?articleid=4349&SMSESSION=NO); Internet; accessed 27 July 2006.

67 Based on analysis of Joint Staff, 1999 Planning Conference for the New Independent States, *Peacetime Engagement Planning Reference Book*.

68 Figure provided by senior USACOM exercise planner. Figure does not include the cost of the 7,600 mile airdrop.

69 The author was the recipient of the OSD staffer's outburst. Another officer present suggestion staffer read the ES-NIS and the UCP for a better understanding of the responsibilities of Combatant Commanders.

70 Алматынская страйкбольная команда "КАЗБАТ", <http://www.kazbat.kz/>

71 *Kazakhstan News Bulletin*, "Abizaid Visits Kazakhstan, Strengthens Military Ties," Vol. 6, No. 29, (4 August 2006) [on-line] available from [http://www.homestead.com/pros-ites-kazakhembus/August\\_4.pdf#search=%22KAZBAT%20%22](http://www.homestead.com/pros-ites-kazakhembus/August_4.pdf#search=%22KAZBAT%20%22); Internet; accessed 8 July 2006.

72 For an excellent discussion of KAZBAT see Roger N. McDermott and Col. Igor Mukhamedov, "Kazakhstan's Peacekeeping Support In Iraq," *Central Asia - Caucasus Analyst*, 8 January 2004 [on-line] available from [http://www.cacianalyst.org/view\\_article.php?articleid=2067&SMSESSION=NO](http://www.cacianalyst.org/view_article.php?articleid=2067&SMSESSION=NO); Internet; accessed 8 July 2006.

73 Based on several private discussions from 1999-2001 with Central Asian government officials.

74 US Department of State, *Congressional Budget Justification for Foreign Operations*, various years, [on-line] available from <http://www.state.gov/s/d/rm/rls/>; Internet; accessed 8 July 2006.



## **Day 1, Panel 2 Question and Answers**

(Transcript of Presentation)

**Moderated by  
Dr. Mark Gerges—Command and General Staff College**

### **Dr. Mark Gerges**

I'd like to thank our three presenters and now open up the floor to questions. While everyone's waiting, Dr. Baumann, I wonder if you'd go in a little bit ... you didn't get a chance to talk about Haiti at all.

### **Dr. Robert Baumann**

Thanks, Mark. Where to begin. I guess I would just begin with a couple of closing observations about the American experience in Haiti. This was a security assistance operation of sorts, although for 15 years the US Marines were kind of occupying and running Haiti. The idea was to leave something behind that would actually function.

Building the guard, the Garde d'Haiti, was a tricky proposition. They really had to recruit and train from top to bottom. They recruited a force and then the plan was to staff it with US Marines as officers, and folks would be screened to see if they had either picked up some Creole or had an aptitude to pick up some Creole, or perhaps knew French, that would enable them to communicate. Over the first ten years or so, relatively few Haitian officers were brought into the system. When it became clear that the mission was going to expire, sometime in the '30s, in the late 1920s they started to accelerate that process.

This long period of mentoring conducted by the US Marines ultimately resulted in what was a pretty competent force. Unfortunately, the context of the rest of the nation building process hadn't gone quite as well. Dr. Bryant Freeman, who is the Director of the Center for Haitian Studies at the University of Kansas, likes to observe that in a sense, we left Haiti with kind of a loose cannon because the military became the go-to guy, so to speak, for all kinds of functions, because it was the one organization in the country that actually functioned, could be given a mission and expected to accomplish it. It was also the group with the monopoly on coercive capability and it became the instrument of choice for the rulers such as the Duvalier's who had notions about running and plundering the country. So an interesting experiment in that sense.

### **Dr. Mark Gerges**

Questions?

### **Audience Member**

This question is for Bill. It's interesting that you mentioned Meppen because I was in DC and got to hear a panel discussion with Kurt Meppen, somebody from the State Department, and somebody from the World Bank. Kurt's thesis was that we don't have any coherent policies towards the Central Asian states. We have a lot of programs, but we don't have a policy, and without some kind of policy, we're not going to be able to achieve any long term objectives. I was wondering how you would address that, and do we have any policies now?

### **Mr. William Lambert**

We don't. One of the slides in the deck that you didn't get to was General Zini and his most recent book, when they were assigned in '98, he looked up and down and we found nothing. Hank Kron was there at the same time. One of the problems Zini puts out in the book is the stove piping. Every instrument of national power is wielded through an organization who does it somewhat independently. Unless there's some real strong will, there's no way to coordinate and synchronize those efforts. That was certainly the case. So I sat at CENTCOM trying to come up with how do we integrate these and what it is we want to do. DOD, we found, was very much way out in front of other folks, and we didn't find a lot of other agencies particularly talking about what it is that they wanted. We got a little bit of direction from OSD, but it was very evident, and even more so after I served there for three and a half years in a security cooperation type of a program, that nobody had any idea what other agencies were doing.

We added ... within six weeks of getting there I went to the Ambassador and said, "Hey, we've got a real problem. We've got programs that are overlapping, buying different kinds of equipment that are incompatible," and then when you expand that further into the international donor community, it becomes exponentially more important. The Uzbeks would shot gun out, "We need radios." Well, they'd never say what kind, frequencies, this, that, and they'd wind up getting four donors to all give them radios. So there was no policy, at large, within the US Government. I've yet to see any. In 2002 there was supposedly a National Security Council group that got together, but I've yet to find anybody that can actually produce that document.

So it was a significant problem within the military, we had a pretty good idea, but I would submit that our great success in security cooperation ultimately undercut US goals and policies at large, with respect to long term access. I think our programs, and I've talked to General Zini about this at length last year when he was here, I think we sort of undermined the whole program because we emboldened, frankly, in my opinion, guys like Agayev who were originally in Kirkistan, were going to be Switzerland of the Central Asian States. Karimov, certainly was get-

ting mixed signals. And the security leg of our triad of objectives became so strong that I really think it emboldened some of the leaders and that's where I think they underestimated the human rights and democratization and reform aspects. So the lack of a coherent strategy, I think, ultimately kind of put us where we are now.

### **Audience Member**

Dr. Stewart, Center of Military History. Question for Dr. Kipp. With Afghanistan, I understand your point about Afghanistan has never really been centralized, and it probably is not a good idea that we try to create a centralized state, yet a number of our policy goals in the region, cutting back on narcotics, having the government provide some measure of support to the people in the countryside, undercutting the Taliban, preventing the reestablishment of failure in the countryside, which would allow al Qaeda, or something like it, to grow. All of these things require a certain measure of centralized, if not controlled, then certainly power by the government. How do we square that circle?

### **Dr. Jacob Kipp**

I think the traditional Afghan answer would be to say the state has got to be the mediator. What you have to do is have resources in the center which co-op the provinces. The truth of the matter on the drugs is, there is no alternative. If you want to make a profit out there, grow opium. If the center has resources which, in fact, say there's a good to be connected. The simple facts of life, and what the Russians spent an awful lot of resources on, was holding the roads. The roads fed the cities. And the cities were where they saw their ability to spread out from. In a sense, that's where you infiltrate out from those urban centers to transform the rural areas. The problem with the Soviets was they had an ideological notion of what that transformation was going to be, and it was rather alien to most of the Afghan population. It was a notion of drawing out of the cities in the textbooks that had no Afghan roots. I think you have to take into account the values of the local population.

If you've got a scheme for transformation... there's a Congressman in 1946 who said, "We're going to make the world like Des Moines." We haven't got the resources to do that. Somewhere between that, you have to take into account what local values are about. We just published a book, ten essays by a Chinese scholar from Central Asia. By the way, they're the dog that doesn't bark in any of this. Because you talk to the Central Asians, they say, "Talking to Washington is about security." Okay, you want us out there because you have security missions, you've got global terrorism, and that's fine and dandy. When it comes around to stability, you talk about democracy, we want regime survival, we want stability, we know we have cleavages inside our societies, and thank you very much, we don't want them

to blow up in our faces. Our answer, if you want to democratize this, is we have to have development. We have to get the pie constantly larger so that nobody figures they're being left out of the game. And when the Central Asians talk about development, guess where they look? East. The new Great Game is not north/south. It's this intriguing arrangement that the Russians and Chinese have made. Understand, it's an arrangement where the Russians are deferring to the Chinese, because the Chinese have the economic presence, the capacity to talk about transformation. And that transformation is, in fact, what goes on in countryside and villages.

Now, Westerners who talk about Afghanistan in terms of what we're going to do with it, very often centralization goes along with economic objectives. Well, there's going to be a pipeline going through. Well, a pipeline comes down to exactly who in the local area is going to benefit and who is going to lose? What are the consequences of changing those relationships? My perception from the Russian perspective is they tried to do that. They tried very much to create a country in the model of their ideology. And they actually had an elite, God bless them, who thought this was the road for their country. They managed to create almost national suicide over it.

#### **Audience Member**

We want to impose a strong central government on a country that's never had one. The power has always been [inaudible] in Kabul. Kabul has always been [inaudible] in doling out resources to whoever needs it, but the power in Afghanistan is tribal, it's ethnic, and Kabul has always been a fallacy. Now it's trying to bring in a strong central government that controls. It isn't an easy marriage. Karzai is, I think, rather adept. He realizes what he has to do, but Karzai also has to play to an audience that's bigger than Afghanistan. He's got to play to the people that are supporting him. I think a lot of times we don't understand the game Karzai has to play there.

#### **Dr. Jacob Kipp**

I would add one thing. There was kind of a Golden Age for the kingdom in '73 during the Cold War, because the Russians and the Americans were pumping aid in, in a kind of competition. We've got good projects for you. And those kind of projects the world definitely could use to mediate with the provinces. We've delivered this, we've done that. Without having gotten taxed, without any tribe who opposed central authority. Economic and social resources may be a more important ... find a developmental alternative for what has, in fact, become entrenched in the drug economy.

I'll tell you what, for four years I sat looking at security in Central Asia, when the common complaint of all the Central Asians and the Europeans was Afghanistan

is, in fact, a huge drug producing area and there doesn't seem to be any way to control it. Part of that, of course, is a problem with cooperation of local police and authorities. One of the papers in one of the conferences was on the Russian border guards in Tajikistan. The reporter was a scholar for the Ministry of Internal Affairs and said basically they're corrupted, they're part of the problem.

You go back to that ... okay, this is a really, really complex set of businesses, and I think probably complexity theory is what we've got to impose on it because the notion of taking a single variable and saying, "That's going to do the thing." We've got to look at second, third, fourth order consequences. My own notion is man, we manage through. We don't solve. We manage, get the level of violence down, we make the situation tolerable, we give the government enough acceptance of legitimacy, enough power that it has legitimacy for itself, and then let the Afghans work out their own way of going.

**Audience Member**

Yes, thank you. This sort of follows up what Dr. Kipp was pointing out. When I was first in Afghanistan in the Spring of 2003, I was chatting with one of the Ministers of the Environment, even there they recognize, again ... Karzai recognized it. Certain decisions were too important to be left up to one tribal decision maker, so any water project had to be decided by four separate ministries, each of which had a member of a different tribe in charge of it.

*[Audio abruptly ended mid-sentence.]*





**If You Build It, They Will Come: The Case for  
Establishing Standing Reserve Civil Affairs Packages  
for Nation-Building and Security Assistance Operations**

(Transcript of Presentation)

**Captain Kris Alexander—Texas ARNG**

Good afternoon. I'm Kris Alexander. I'm from the government, and I'm here to help. That goes over real well in the great state of Texas with all the rugged individuals. It's pretty much a mouthful for what I'm going to talk about today, but in our theme of breaking out of the box, we're going to talk about new ways of looking at doing Civil Affairs, humanitarian aid, nation building. Whatever you want to call it. First, an introduction, then I'm going to talk a little bit about are we broken in our capability, and the limits of how we have Civil Affairs structured in the military. Particularly focusing on how Civil Affairs units are structured and limited in the Reserve force, some possible solutions, and then, of course, discussion.

Introduction, a little bit about my background. I'm recently back on active duty in the Active Guard Reserve Program in the Texas National Guard on a weapons of mass destruction response team. Every state has one, and we spend a lot of time working with local, state and federal agencies. So I spend a lot of time out in the civilian community. I come from the Emergency Management community. I worked for both the state of Texas, and Travis County, Texas, where I did Homeland Security, Hazardous Material, WMD planning. By trade, I'm an Intelligence Officer, but I do a lot of the other stuff that would make me sound more like a Chemical Officer. My perspective is I've done some unusual things and I've seen what the American people have to offer the military when it comes to nation building.

This picture here, with a little longer hair, this is the Austin, Travis County Emergency Operations Center during Hurricane Rita last fall. This must have been either at the very beginning or the very end when it was finally over because we didn't have much to smile about during. In that period, in a 72 hour period during evacuation, Austin, Travis County sheltered over 40,000 people in over 200 shelters. This is from the old and very sick to the mentally incompetent. People who had tremendous special needs. People who had nothing. We did all these things, in addition to sheltering the already 5,000 Hurricane Katrina evacuees we had in our city. I think you would be stretched to find a battle staff that could accomplish something similar.

So this is me on a Hazardous Material exercise, and this is me ... I'm one of those guys that is dumb enough to actually suit up in one of these Level A mobile Hopi sweat lodges that ... so I've worked a lot with the responder community. A lot with fire fighters. A lot with all these entities that we are not tapping into. One thing you'll notice is we've got a lot of great people in this picture who are really competent, capable people who can do a lot of things, but they're not. They are not in Iraq, they are not in Afghanistan.

Are we broken? I don't think our capability to do nation building, support and stability operations is broken. But we will become engaged in these type of things again. We have the ongoing requirement in Iraq and Afghanistan and elsewhere, there's hot spots throughout the world where we may become engaged. So our Civil Affairs plays a vital role, but they can't do it all. So I say we need to fix what's broke with our capability.

The biggest thing is, if you look at our federal government, we don't do nation building. We're not structured to be imperial or expeditionary in our federal government, outside a few select agencies. I also think that if we task the federal government with doing this, it would move at glacial speeds. See the creation of Department of Homeland Security (DHS) for a good example of how not to create a new capability. I don't think the military can wait for the federal government to catch up.

There are some limitations to how Civil Affairs is currently structured in the military. 97% of Civil Affairs soldiers the military has reside in the United States Army Reserve. These are low density, high demand units and they are stretched thin and expended. We're talking about 200% mobilization and deployment rates within Civil Affairs battalions. Guys on their second and third tours, units that are constant revolving doors of people coming and going.

Civil Affairs is effectively the recruiting pool, how we get people is limited to the United States Army Reserve (USAR). It's really limited by ability and interest. Not everybody is suitable to do this job. Then we also have trouble putting the right leaders in the battalions. One of the things that limits our capability is demographics. 299 million Americans, this is how it breaks down, we have taken, almost 300 million of us, the burden on our support and stability operations on 7,000 soldiers in the US Army Reserve.



battalion, we had two cops in my battalion. One guy was on the SWAT team, he was a homicide detective. Oh, by the way, he was a Warrant Officer. On paper, looks great. Another guy who was a narcotics detective, but he was the Food Service NCO. If you were querying the database, who would look better? Well, the guy on the SWAT team. The truth was, he was a nice guy, but he was a Sheriff's Deputy from very rural jurisdiction where everybody was on the SWAT team. He was a homicide detective in a jurisdiction that had no homicides. The Food Service NCO was one of the most competent guys I ever met in my life, was a narcotics detective in Houston. At one point, he had the most confirmed kills out of any cop in the city of Houston. He was like something out of a Tarantino movie, but the database wouldn't have told you that.

Further, if we cross-level people out of their parent units to put them in a Civil Affairs (CA) mission, we create the human spackle effect. We pull them out of their units, we break a unit to fill another capacity. We don't know if they're capable of actually doing it. Here's another argument against relying on this. Charles Graner was a prison guard and his inexperienced unit relied on his expertise to help run Abu Ghaib. Well, you can see where that got us.

Our next possible solution, do we expand Civil Affairs in the Army Reserve? Can we really recruit and retain more people? One of the things, maybe we offer incentive pay to the people who have the skills we need, but we might run into the problem of paying a Charles Graner incentive pay to stay in the Army so he can ruin things later on down the road. The other problem is the traditional target recruiting demographic, the 18-year-old that we go after, they don't really bring the skills that we want for nation building. We want somebody who's got the hard skills now. They compete for the best and the brightest. Which branch do we leave out in the cold? Do we say, "Military Intelligence (MI), you're trying to expand your capability too, but you don't get the recruits. We're going to send them over to Civil Affairs."

One of the things, when we talk about Civil Affairs, the Chief of the Army Reserve has some great things to say about the richness of the force. And it's true. We bring a lot of great people into the fight. But the Secretary of Defense ... this is another thing. We go to war with the Army, and we have. In Texas we have an expression, "You dance with the girl you brung." So right now, we're hoping the people we recruited in the '80s have grown into the fire and police chiefs that we say the Reserve force brings to the fight. We're hoping that these Lieutenant Colonels and these Sergeant Majors and these Master Sergeants have gravitated towards a Civil Affairs unit. If not, we're hoping we can somehow access them.

The next option is contractors. But there's some limits to this. I'm running a little low on time, so I'll gloss over this. But this is something I hear over and over again when I'm dealing with the community that I deal with. I'd love to do something, but ... I'm the captain on a fire department, I'd love to do something, but I'm not going to give up my career to go be a contractor. My job's not going to be waiting on me. So your contractors are limited to the willing segment of the population that can put their careers on hold, and potentially jeopardize them, to go do a year in Iraq. So there's some limitations with this. Also, contracting creates a problem. Can we contract fast enough when we win here to instigate the rebuilding? It costs us in Iraq, having that gap.

My fourth option is a new business term called crowd sourcing, where corporations look outside their companies to find people. So let's crowd source America, is my proposal, to create a reserve civilian component to the USAR. We recruit skilled professionals outside the typical target demographic. Let's quit looking for the generation Y, X-box kids, and let's look for hard, skilled professionals. We can organize them into units or packages, and it allows us a way to train, retain, and utilize more of the population.

How we could do this, we could have them complete initial training, drill monthly with their unit, and participate in annual training, and join with the understanding that they may serve in dangerous areas of the world. I guess this is the life cycle of the new force. You get them entered, you align them and allow them to train. One of the great opportunities I've had in the Reserves is I did a COBRA GOLD exercise a couple of years ago. Why couldn't you leverage a Civil Affairs component on with exercises like that? So this allows you to have trained teams, versus contractors or collections of individuals, that augment existing Civil Affairs skill set and fills a gap between the military and civilian skills.

Who do we recruit in all this (Slide 2)? Well, the first thing we could do is poach capable people from other government agencies. Federal Emergency Management Agency (FEMA), United States Department of Agriculture (USDA), US Forest Service, places that people have the skills, but we have to go to the government and say, "Mother, may I? Can I borrow them?" and work through that process. Some of their highlights, agriculture being one place that we don't have a lot of expertise at in the military, emergency services, public health. Of course, you probably think I was smoking something when I put these last two on there, but establishment of the rule of law is very important. And then journalists, having a free, open press that does the job of reporting for society. They're the people that could train society.

So the precedence is always [inaudible] people are looking to serve in the global war on terror. An example is the company I commanded when we were first mobilized, we had gone through some restructuring, and on September 11, we were at 30% strength. When we mobilized on October 17, 2001, we were at 70% strength from all the people that had gravitated towards our unit from other units, out of their area of responsibility (AOR), because they wanted to get in the fight.

## Who to Recruit?

- Existing government employees (FEMA, USDA, USFS, etc.)
- Skills that compliment or expand existing CA disciplines
- Agriculture
- Education and Academics
- Emergency Services
- Small Government
- Small Business
- Financial/Accounting
- Medical
- Public Health
- Utilities
- Communications
- Linguists
- Technology Sector
- Legal
- Journalists
- More...

Courtesy of CPT Kris Alexander, ARNG

SLIDE 2

Some of the advantages. This would allow us to get this guy by hoping he grows into what we want. I think this is the big thing. The American people, I interact with them a lot, there's a lot of people out there who want to do something, and they are not invested in the fight. Of course, the disadvantages, overcoming the geography. The Reserve MI has done this. For the low density (Military Occupational Specialties) MOS' they will actually pay people to fly across the country, Temporary Duty (TDY), to drill with their units because their specialties are so hard to find.

Financial. These people might be expensive. Will we really pay them what they're worth. There's also some legislative and legal requirements. We would have to create this force legally and extend the protections that Reservists and Guardsmen have to these civilians.

So my recommendation is to initiate a pilot program. I'll highlight Houston being an interesting place to think about doing it. We have 90 languages that are spoken in the city of Houston. 83 consulates from foreign countries are there. And a Civil Affairs battalion. It would be a great place to recruit people that you could use globally. This concludes my presentation.





**Send in the Amateurs! Recruiting from the  
Private Sector to Accelerate Nation-Building:  
The Experience of the Afghanistan Reconstruction Group**

**By Thomas F. Berner**

**Summary**

Problems and delays in the Afghan reconstruction program began almost immediately after the program was initiated in 2002, leading Washington to consider ways to accelerate the process. In an effort to coordinate and monitor the reconstruction process, an experimental unit known as the Afghanistan Reconstruction Group, or ARG, was created to assist the effort without creating an additional bureaucratic overlay to the process. Reporting to the State Department, but recruited from both the private sector and other areas of government by the Department of Defense, ARG was not given its own budget but was tasked with the mission of accelerating reconstruction. For a variety of reasons, ARG faced a fair amount of opposition within the embassy, leading to a transition in its role from that of inspecting and coordinating the efforts of other agencies to that of cooperation - providing “new ideas” to other agencies and serving as mentors to cabinet officers. The transition did not improve relations with the rest of the embassy and it is not clear whether ARG has proved effective in its new role or whether the new role has led to the marginalization of ARG in the reform process. Nevertheless, in a questionnaire circulated to people who worked for or with ARG, nearly all respondents believe that an entity like ARG has a valuable contribution to make to reconstruction.

**Introduction**

Former Secretary of the Army Martin R. Hoffmann has observed that after every conflict there is a “golden moment” in which reconstruction and nation building is most easily accomplished. This is the moment after significant hostilities have ceased and before opposition to reform has had an opportunity to gel. America’s most successful reconstruction effort occurred at the end of World War II when Europe and Japan were quickly and successfully returned to the world economy and, for the first time in their history, a number of nations adopted basic human rights and democratic institutions. The occupation of the Axis countries was administered by civilians, most of whom lacked significant development expertise, operating under the direction of the United States Army. They restored and

improved health care, education and legal systems in these countries and setting them on the road to becoming democracies.

Since World War II the United States government has institutionalized foreign aid and development work, creating a professional cadre of civil servants devoted to providing assistance to countries throughout the developing world. It has, however, never again experienced the success it enjoyed in the post-war era. Many people, within government and without, believe that the institutionalization of development work is linked to the less successful efforts since that time and that the bureaucratization of America's foreign aid has resulted in an inefficient, ineffective and even counterproductive effort, creating discontent in the country. In Afghanistan, for instance, it may not be a coincidence that rioters tend to target NGOs, including USAID contractors and that there are constant bureaucratic skirmishes between the Afghan government and USAID, among other aid agencies.<sup>1</sup>

Some think that it is time to revisit the history of reconstruction to determine whether the success of the past can be recreated by leavening the mission with talented amateurs instead of relying exclusively on professionals. Amateurs, that is, in the best English sense of the word: people who do not have a vested interest in making a career out of reconstruction and are "honest brokers" (as one Army officer has called ARG) who treat the country they're working in as a unique culture, instead of just another gig.

In the fall of 2003, an effort to remove the bureaucratic constraints on the Afghan reconstruction effort led to the creation of an experimental unit within the Department of State, known as the Afghanistan Reconstruction Group, or "ARG". The members of ARG were recruited from both the private sector and from government agencies other than the Department of State. Former Secretary Hoffmann, who conceived of ARG, supervised recruiting from the Pentagon.

I was privileged to be the first legal advisor on the team and served in Kabul from February, 2004, through February, 2005. In explaining the efforts and controversial history of ARG, I have attempted to present both sides of the story by circulating a questionnaire to as many people who worked with ARG as I could locate. Those sent questionnaires included Ambassador Zalmay Khalilzad, past and present ARG members, USAID and State Department officials, USAID contractors and members of unaffiliated NGOs. A copy of this questionnaire is attached as Exhibit A. Thirty five people responded, including 12 who are past or present ARG members, 10 from the military, four from the State Department, five from USAID, two from USAID contractors and two from unrelated reconstruction entities. The results reported in Section V must be read with an understanding of their

limitations because there is no way of determining whether or not they represent an accurate cross-section of attitudes toward ARG. I have attempted to confine my own “war stories” to the footnotes except where the context requires them to be mentioned in the text.

## **The Problem**

In his study of the failure of United States government efforts in Vietnam, *Bureaucracy Does Its Thing: Institutional Constraints on US-GVN Performance in Vietnam*,<sup>2</sup> Ambassador Robert W. Komer, former Chief of Pacification for the U.S. government in Vietnam, argued that “the typical behavior patterns of . . . U.S. institutions involved in the conflict made it difficult for them to cope with an unfamiliar conflict environment and greatly influenced what they could and could not, or would or would not, do.”<sup>3</sup> Both the military and civilian agencies, he argued, behaved in a bureaucratic manner, which proved self defeating. They behaved in this way because their institutional imperatives prevented them from behaving in any other fashion. Bureaucracies, whose *modus operandi* is to rely on precedent whether or not it is appropriate, to resist change, and to block outside interference in their operations, are incapable of readily adjusting to a new environment.

Ambassador Komer noted several interrelated attributes, common to all bureaucracies:

*Reliance on Precedent.* Bureaucracies, argues Komer, tend to shoehorn new policies or environments into familiar processes rather than try to learn how to cope with new situations. “Bureaucracy . . . tends to contort policy to existing structures rather than adjusting structures to reflect change in policy. . . .”<sup>4</sup>

*Self Referential.* Bureaucracies have a tendency to define the world around them in terms of their own terms of reference, whether or not those terms have any bearing on reality. Ambassador Komer writes: “the way in which an organization will use its existing capabilities is governed largely by its own internal goals, performance standards, and measurement and incentive systems – even when these conflict with the role it is assigned.”<sup>5</sup> Ambassador Komer quotes Henry Kissinger: “our heavy bureaucratic and modern government creates a sort of blindness in which bureaucracies run a competition with their own programs and measure success by the degree to which they fulfill their own

norms, without being in a position to judge whether the norms made any sense to begin with.”<sup>6</sup>

*Institutional Inertia.* Another attribute of bureaucracies is their inability to adapt. “A hallmark of bureaucracy is reluctance to change accepted ways of doing things. Bureaucrats prefer to deal with the familiar. To change may be to admit prior error—a cardinal bureaucratic sin... Organizations typically ... shift only slowly in response to changing conditions.”<sup>7</sup>

*Lack of Unified Management.* Each agency resists outside efforts to direct its performance and fights its own separate war. “The institutional constraints created by the way the U.S. Government dealt with the war in largely separate bureaucratic compartments, with little attention to unified management, diluted managerial focus and impeded adaptation to . . . special circumstances.”<sup>8</sup> This is as more the fault of each “bureaucratic compartment” than it is of those with titular control over them because the bureaucracies are resistant to outside interference, even from above.

*Lack of Institutional Memory.* Turnover of personnel combined with inadequate “lessons learned” procedures prevents progress. Ambassador Komer quotes US Army officer and USAID official John Paul Vann about Vietnam: “We don’t have twelve years’ experience in Vietnam. We have one year’s experience twelve times over.”<sup>9</sup>

Bureaucracies, by their nature, are “priesthoods,” claiming sole control of an esoteric body of knowledge. At their worst, bureaucracies use this priesthood status not only to prevent outside interference with their mission, but to blind themselves to flaws in their operations. Bureaucracy calls to mind Talleyrand’s comment about the ancien régime: “They forget nothing and they learn nothing.”

Since Vietnam, the U.S. military has made great strides toward minimizing the bureaucratic effect inherent in large institutions, most notably since the Goldwater-Nichols Act of 1986. Civilian agencies, however, have largely escaped the sharp scrutiny that forces a bureaucracy to reform. Having escaped the stigma of “losing Vietnam,” they have felt no pressure to change. An effort to reform USAID in the mid-1980s failed, resulting in merely cosmetic changes, such as bringing the agency into the Department of State, but as an independent entity with its own recruiting and chain of command. The only significant “reform” in the last forty years was a negative one. In the 1990s USAID was restructured, outsourcing its work to a handful of private contractors and stripping the agency of its engineers

and inspectors, and, as a result, leaving it at the mercy of its contractors and leading to a loss of quality control over its own projects.

After the defeat of the Taliban, USAID was called on to tackle a massive reconstruction effort that was far larger than anything the agency had ever done before. Whereas the typical USAID mission is limited to a small number of officers overseeing a handful of projects. The USAID Mission in Kabul had to construct hundreds of projects around the country. Robert Jimenez, the acting program officer of the mission from 2002-2004, noted “USAID has never had sufficient staff to plan, especially in Afghanistan, where just keeping up with daily management of programs took all of the available time of the CTOs.”<sup>10</sup> Another problem pointed out by an ARG member who was seconded to a State Department slot was that “embassies are built to work with existing governments, not ones that need [to be] built from the bottom up.”

Further complicating its mission in Afghanistan is that USAID still suffers from all of the shortcomings that Robert Komer identified almost thirty five years ago. This is not the fault of the people working for USAID, who are as hard working and dedicated as any group of civil servants in the world;<sup>11</sup> even the best people do not perform well in a poorly structured organization and the feeling is strong among many in the United States that USAID is such an organization.<sup>12</sup> Combined with a Byzantine procurement system,<sup>13</sup> USAID’s contribution was decidedly mixed despite the best efforts of its talented staff. Some of the complaints in the questionnaires included USAID’s “chronic” resistance to refocusing priorities, its “culture of non-accountability for results” and the absence of “the sense of urgency required in a failed or failing state or in a post-conflict environment.”

### **Creation of the Afghanistan Reconstruction Group**

The Afghanistan Reconstruction Group was organized by former Secretary Hoffmann in 2003 when it became obvious that the “business-as-usual” approach to reconstruction was in danger of making Afghanistan another Haiti or Kosovo. Former Secretary Hoffmann, a lawyer, former paratrooper, former General Counsel of the Department of Defense and Secretary of the Army under President Ford, is close to Secretary of Defense Donald Rumsfeld and, since September 11, 2001, has been working long hours at the Pentagon for the munificent salary of \$1 a year. With the assistance of Hernando de Soto, the leading expert on private enterprise in the developing world, he conceived of the idea of a small group of advisors, recruited from both the private and the public sectors, and reporting directly to the Ambassador. After lengthy consultations with the Department of State and USAID, ARG was authorized as a special group on the State Department payroll.

It didn't have its own budget and relied on the embassy for security, transportation and logistics.

ARG members faced long delays in obtaining the necessary approvals from the State Department.<sup>14</sup> The Public Affairs Advisor arrived first with two assistants and shared office space with the State Department's Public Affairs Office. The next group to arrive, in January 2004, were two people seconded from other government agencies (the Senior Economic Advisor from the Department of the Treasury and the Senior Natural Resources Advisor from the US Geological Survey) and the Chief of Staff, Jack Bell, along with ARG's executive assistant, Ceil St. Julian. Mr. Bell had had a varied and successful career in the private sector, most recently as a consultant on "turnarounds" of distressed corporations. In February 2004, the Senior Legal Advisor and the Senior Health Care Advisor arrived. Over the next several months, advisors on elections and education arrived, as well as Brigadier General Patt Maney, US Army Reserve, who was to serve as the Deputy Chief of Staff (and who also supervised election work). General Maney was a sitting judge in the State of Florida with nation-building experience in Panama, Haiti and Bosnia. Still later arrivals included experts in agriculture, private investment,<sup>15</sup> privatization, aviation, water and infrastructure. As the group got larger, it split into two parts: General Maney became the Deputy Chief of Staff for social reconstruction (education, agriculture, healthcare, law and elections) while Mitchell Shivers, who had served in the Marines prior to a distinguished Wall Street career, became the Deputy Chief of Staff for economic reconstruction (economy, private investment, privatization, aviation and infrastructure).

Each advisor developed an individualized approach to his sector that depended on the number of agencies working in his or her field, the advisor's assessment of the most effective way to work with his or her colleagues and the most serious problems that needed to be addressed. ARG Economics Advisor James Wallar described to me how various members tailored their style to meet the demands of their work: "Said [Mirzad, the natural resources advisor was] better at building an Afghan team; you [at] building effective legal advice; [Kaivon Saleh, health care advisor] at critiquing USAID approaches, Jack [Bell, chief of staff] at problem identification and solving, Patt [Maney, Deputy Chief of Staff] at institution building, I guess I was more of a team builder and access to Ambassador type." The approaches fell into one of three categories:

1. Filling the Gap—in areas where other agencies did not have significant projects, ARG members were able to focus on providing advice to the ministries in their field and initiate projects of their own.<sup>16</sup>

2. Coordinators—some sectors, such as economics and law, had a plethora of agencies involved, each running their own projects. The ARG members in these areas attempted to coordinate activities, or at least let the left hand know what the right hand was doing.<sup>17</sup> A good example of the need for coordination was reported by an ARG member: “On one occasion, one Afghan Ministry (Communications) had been given funds to construct a rather expensive wall around a facility. The next week another Ministry contracted to tear down a part of the wall to widen a road under another U.S. funded project.”
3. One on One—where the number of entities affecting a particular sector was small, the ARG member would focus his energies on providing advice to those entities.

These approaches evolved naturally. As a coordinator, I had to provide a range of legal advice and participate in a variety of projects, while keeping the various entities aware of what other entities were doing.<sup>18</sup>

## **Conflict**

It was perhaps inevitable that there would be friction between ARG and the rest of the embassy. There were a number of reasons for this.

1. There was the perception that ARG was an affront to the Embassy’s efforts. As one career State Department officer put it: “I think the ARG could have been more effective if . . . the traditional governmental entities could have overcome a sense of mistrust based on what I think was a false impression that the ARG’s existence somehow suggested that they themselves were not fully trusted to accomplish the goals of the Mission.” One of the authentic heroes of the reconstruction, an Army Colonel who almost single handedly converted Rabia Balkhi Hospital from a charnel house to something resembling a place of healing, observed that ARG “was affected . . . by the level of understanding and support that it initially received by the in-country U.S. program leaders, where many were threatened by the external eyes and ears of the ARG experts.”
2. ARG being a Department of State entity hired by the Department of Defense, the traditional interdepartmental rivalry between State and Defense flared up. As one respondent from USAID put it: “There were times when US political biases, particularly the tension between State and DOD, was introduced in an unnecessary and counterproductive manner by the ARG.” An ARG advisor believed that “ARG lost most of its chance to be effective for a variety of factors.

First and foremost was the decision to have ARG recruited and reporting to DOD while being State employees. State saw ARG as competitors and spies rather than as the resource we should have been. USAID was appalled at our presence and looked upon us as spies and backstabbers whose only loyalty was to the Ambassador and whose only job was to point out AID's faults."

3. The nature of ARG's mission, to "accelerate reconstruction," without a budget for our own projects required ARG to become involved in the projects of other agencies. No matter how tactfully this was done, it still brought ARG into conflict with existing agencies.<sup>19</sup>

4. ARG had a degree of freedom from bureaucratic red tape that the other agencies lacked, which had the effect of making ARG appear to be a privileged group.

5. There was a perception that ARG members were not experienced in development issues.<sup>20</sup>

6. ARG members were perceived to be arrogant. A USAID contractor reported that "ARG didn't coordinate enough with others in the USG and outside parties (ARG isn't alone in this criticism); some (not all) in ARG seemed less willing than others to ask questions rather than provide answers (probably given that many in ARG have been giving orders in the private sector and have been largely successful, I think that some in ARG were a bit too self-assured that they knew what is best for Afghanistan and American interests there)."<sup>21</sup>

### **Reformation of the ARG**

In September 2004, Louis R. Hughes, who had most recently been CEO of Lockheed Martin Corporation but had spent most of his successful career at General Motors Corporation, rising to the head of its international division, replaced Mr. Bell as Chief of Staff of ARG. Mr. Hughes believed that the rift between ARG and the rest of the Embassy needed to be addressed. To do so, he necessarily had to shift the role of ARG away from redressing deficiencies in the reconstruction effort toward a spirit of cooperation, providing "new ideas" to USAID and, in the words of Mr. Hughes, "serving as coaches or mentor to ministers within [the] Karzai cabinet."

This new approach was welcomed by the equally committed Mission Director of USAID, Patrick Fine, who reported that "the role of the ARG shifted during 2004/2005 from one that was predominantly focused on inspection/quality control



to one more focused on introducing new ideas, facilitating action among all sections of the Embassy, and offering technical advice, not only to the Ambassador but increasingly to the GOA [Government of Afghanistan] and to other sections of the Embassy. I think this was a positive development and I attribute it to the leadership of Lou Hughes and David Grizzle [ARG's Senior Aviation Advisor]."

The transition did not, however, reduce the level of distrust that the rest of the embassy felt toward the ARG and it apparently reduced its influence. When Mr. Hughes was replaced by Edward Smith in September of 2005, the same animosity was evident and ARG's effectiveness had apparently been neutralized. Mr. Smith, who had most recently served as the CEO of PSG International LP, a joint venture between GE Capital and Bechtel Corporation, reported "When I arrived in Kabul as Chief of Staff in September 2005...the ARG was viewed, almost universally by the non-ARG members of the embassy and USAID as a DOD organization with an objective of taking over AID and running the embassy. ARG was viewed as unnatural and unwelcome competition. The anti-DOS perception of the ARG made it an easy target for the career DOS and USAID staff which led to marginalization of ARG staff members. The resistant attitude towards ARG was almost universal across sectors."

Support for Mr. Smith's analysis can be found in two questionnaires that were the most hostile of any received.<sup>22</sup> The continuing nature of the hostility was echoed by a current ARG member who reports that ARG has had only "modest accomplishments due to the lack of support, institutional barriers and hostility."

Mr. Smith believes that the attitude of the embassy has now changed: "Extensive efforts to rebuild relationships, demonstrate areas where value was being added and working as a team with AID and DOS have contributed significantly to a turn around in the reception of ARG. The Ambassador now recognizes the contributions we have made, are making and can make in the future. Unfortunately, considerable effort was expended in just turning around the negative impressions. We worked hard to build team, coordinate and cooperate with DOS, AID, and the military to make all efforts more productive. It worked well but required continuing efforts, particularly when the efforts expanded to include the wider donor community and the GOA."

Perhaps owing to the small number of questionnaires returned by people currently serving in Afghanistan there is no confirmation of Mr. Smith's report, but there seems to be at least a lingering dissonance between ARG and the rest of the Embassy. Even some of those within the Embassy who praised ARG for introducing "new ideas" also say that ARG hindered the reconstruction process by forc-

ing USAID to sort through the bad ones. One officer at USAID, who welcomed ARG's support, said that ARG "made the USAID managers take valuable time to rebut ideas which were not workable. In these cases, the ARG became part of the problem and not the solution." This comment was echoed by an ARG member who believes that the "ARG staff was very good at coming up with ideas and methods but not as effective in making those ideas work." Some ARG members agreed with some of the criticisms, a recent ARG member reporting that "some ARG were guided by their own ideas as opposed to established USG policies sometimes even working in opposition to established USG policy."

Nor was the transition to mentoring of cabinet ministers accepted by the rest of the embassy without objection. Well before the ARG arrived, the Coalition had installed advisors in each ministry, most of whom were highly effective as both sources of information within the ministry and as mentors to the ministry. Yet one complaint was that "USAID is often in the business of cutting deals with developing country counterparts in accordance with the US government procurement rules. To do that, it is necessary for USAID to build and rely upon strong continuing relationships with counterparts. Yet, inherently, the ARG seemed to behave as if it thought that those relationships belong and should belong only to the ARG. [ARG members made] promises to counterparts regarding resources that are not consistent with US government procurement rules and that went far beyond the normal role [in] . . . executing policy. This is a critical problem and one that I think is inherent in the ARG function."<sup>23</sup> An Army officer also believed that "some entities were wrongly waiting or relying on the ARG to fix the problem, when the ARG had no resources to do so."

Finally, judging from e-mails I received from Ambassador Brunetti, the head of the Italian Justice Project, after my return home, at least in the legal sector, ARG was no longer focused on addressing the bureaucratic deficiencies of the reconstruction process and ceased to put a priority on coordinating efforts of various entities. Ambassador Brunetti reported that USAID had ceased to cooperate in any significant way with the Italians and that no one is trying to link the US effort with the Italian effort.<sup>24</sup>

Several respondents from all categories (other than military) questioned the necessity of ARG as an independent entity. Certainly, by eliminating its role as an inspector of USAID procedures and as coordinator of efforts, the necessity of ARG as an independent entity is now in question. If its mission is to supply new ideas to USAID and to mentor the cabinet, the need to streamline the organizational structure would suggest that its new mission is best served by changing the hiring mix at USAID and its contractors, rather than to create a new bureaucracy.

Despite the negative comments reported above, of the 33 respondents who responded to this question on the questionnaire, 29 believed that the ARG was a useful model for future reconstruction efforts while only four believed it was not (including one ARG member who believed that State and USAID opposition was so great that such an organization would never have a chance to succeed).<sup>25</sup> A much larger agency, created by the State Department but having a similar mission to ARG, the Iraqi Reconstruction Management Office, or IRMO, has been established in Iraq, but it is too early to determine its effectiveness.

### **Critique**

When asked to rate the effectiveness of ARG from “1” (least effective) to “5” (most effective), the various sectors did not vary much: the military’s average rating was 3.3 out of 5 (10 respondents), ARG’s average rating of itself was 3.5 (12 responses), State Department officials rated ARG a 3.25 (4 respondents including Ambassador Khalilzad), USAID a 2.8 (five respondents), USAID contractors a 2.5 (2 respondents) and two persons outside of the above categories rated them 2.5.<sup>26</sup>

- One of the failures mentioned was a lack of strategic direction and ill-defined Tasks of Responsibility, which prevented the ARG from being consistent. There is some evidence of this in questions 2 and 3 of the questionnaire, where I asked what the role of ARG was and what it should be. Most respondents rated “Advisory” as a 1 or 2, but after that, there was no consistency either among ARG or other respondents as to what ARG was doing or should have been doing. In defense of ARG, however, two things should be pointed out. First, a collection of advisors each with responsibility for a separate sector of reform would be expected to develop different strategies with respect to their sector. If ARG’s role was to determine the flaws in the reconstruction process each sector can be expected to have different flaws, requiring a different approach to dealing with them. Second, even if a unified strategy is appropriate, a new organization needs to determine the lay of the land before it develops such a strategy and the first year or two of any new organization necessarily requires that a number of strategies be tried.
- There was a wide difference in effectiveness depending on how ARG was employed; several respondents noted that Ambassador Khalilzad was far more effective in using ARG than his successor was. Although I did not work with his successor, Ambassador Khalilzad employed ARG very effectively in a variety of roles. For instance, he expected ARG to act as his staff, developing full knowledge of activities in their sectors.

This “one stop shopping” saved him considerable time in finding answers, especially in the sectors where activities were decentralized.

- A significant minority (8 respondents) thought that the level of effectiveness of ARG did not vary with the individual but was endemic to the nature of ARG’s structure; most thought that its effectiveness varied from person to person depending on their abilities or the nature of the sector.
- When asked (question 12 of the questionnaire) whether certain aspects of ARG were useful or harmful to the reconstruction process, everyone who answered the question agreed that the diverse background of its members was a distinct plus. Beyond that, there was no agreement on the usefulness of any particular characteristics, although there was more of a consensus within the various categories of respondents.<sup>27</sup> Notable here is that only at USAID did a majority of the respondents think that ARG should not have a budget and that ARG was not benefited by empowering its members to act independently. In addition, USAID officials were the only US government respondents who did not think that recruitment outside of DOS and USAID was helpful.

When asked in question 7 to list ways to improve ARG, the respondents did not arrive at a consensus on many proposals, either among the entire population of respondents or within a category:

- Only nine respondents (four of them with ARG) thought that a bigger staff would have improved performance.
- Fifteen (including five of the military and six of the ARG respondents) thought that ARG would have been more effective if they had their own budget. A career State Department official thought that “misunderstandings between under staffed Embassy officials who controlled resources and experienced and talented ARG members who had no resources significantly impacted the potential high impact the ARG could have had. This is not to demean the many successes the ARG had, only to note that it did not come close to reaching its full potential” Another Army officer agreed that “[o]rganizations respond to those with either the money or power. Proximity to the Ambassador helps but he needs to continue to emphasize the ARG as ‘his advisory group’ and then act in a way that others see the influence of the ARG.”
- No one thought recruiting should have come only from the public sector and only four (all of them from ARG) believed that they should have been recruiting solely (or “primarily”) from the private sector.

- Sixteen believe that an orientation session in the United States would have been helpful.

When invited to provide their own suggestions for improvement, several suggested that

- ARG be given a clearer mandate,
- A better effort be made to coordinate and interact with Embassy staff,
- ARG be provided with its own staff rather than rely on Embassy staff,
- ARG have stronger leadership in Kabul,
- ARG should spend “more time outside the wire” (that is, out of Kabul to gain familiarity with actual conditions in the country),
- Recruitment be made from state and local governments, as well as the federal government, since many of the problems which arise are more akin to local issues,
- Instead of ARG having its own office, members should be given offices at the agencies with which they were working (this is the way the public affairs advisors operated and several of the ARG advisors believed this to be a positive step; several ARG communications advisors believed that, in the words of one of them, “the most effective ARG integration with State and USAID was the communications function. A large part of that was because communications was physically located outside the ARG area and hence was able to be more of a part of the Mission.”),
- Embassy staff should be given an orientation to know what to expect from ARG, easing the introduction of ARG members. One State official believed that “early introduction w/o preparation significantly affected the Embassy starting turf wars and daily effort on turf protection versus reconstruction,”
- In the words of one USAID officer, “the types recruited should match an agreed strategy of redevelopment. [It does not do] good to bring an expert for an area in which funding is not planned.”
- A few respondents, primarily from USAID or its contractors, proposed either the elimination of ARG or its incorporation into either USAID or the State Department.

Finally, several indicated a need to resolve recruitment problems. These comments fell into two categories. A few respondents felt that ARG could have used a better selection of personnel. An officer in the military who worked closely with all members of ARG suggested “better screening of the individuals selected for ARG duty can only help minimize assigning someone that is not fit for the conditions/

mission ARG faced.” A more common criticism pointed out the gaps in coverage between personnel being rotated in and out which resulted in lost momentum for projects. As one respondent from USAID put it “The ARG had a problem finding the high quality, private sector expertise that it promised. The high vacancy rate and the experience of some other members made clear that it is difficult to find people .....The ARG never felt it could admit this weakness.” Some members of ARG, equally frustrated, felt that the delays and coverage gaps were the result of State and USAID interference in the recruitment process. General Maney noted that “ARG was highly effective but was hampered by entrenched interests in the USAID and DOS bureaucracy and by delays in filling positions, often caused by the same opposition.”

### **Achievements**

Several ARG members supplemented the list above with their own list of accomplishments. The “gap fillers,” those advisors whose sectors were not covered by major projects of USAID or NGOs were notably successful. Natural resources, telecommunications and aviation all experienced major successes, an achievement all the more remarkable given ARG’s lack of a budget. Jane Wiegand, the Privatization Advisor, managed to complete half of all privatizations which took place during her tenure, with the other half being completed by a contractor under a \$30 million contract with USAID. Before his collapse, William McCampbell’s efforts showed great promise in amassing a private investment fund for investment in Afghanistan.

Those ARG members whose sectors required coordination or working one on one with someone else’s projects also had their successes, although their contributions are harder to gauge since their sectors’ activities were dominated by the projects of other entities. In an institutional wide summary, Mr. Bell believes that “ARG was effective in advising [the] Ambassador and key ministries of the GOA on refocusing priorities in a way to focus on delivering meaningful benefits to both the population in the countryside and toward meeting the preconditions for private sector-driven bottom up economic development.”

General Maney has provided a detailed list: “ARG was particularly successful in establishing senior level contact and credibility at various key ministries. Concrete examples of success are the conceptualization and execution of a minerals inventory at the Ministry of Mines, the conceptualization and development of the US International School of Kabul and the American University as well as the re-orientation of hospital management philosophy from a socialist model to a fee for service model. Considerable contributions were made to the political progress of

Afghanistan including solving legal issues related to the elections and improved coordination with Combined Forces Command–Afghanistan (CFC-A). ARG also contributed to improving attainment of the Ambassador’s political and reconstruction goals by coordinating Commander’s Emergency Response Program (CERP) projects for high visibility capacity-building projects. ARG also assisted high priority humanitarian support projects like Aschiana. (The USAID-administered Denton Program does not function responsively for Afghanistan.) ARG played a critical role in getting the Telecommunications Law and Mines and Minerals Laws enacted as well as criminal and counter narcotics laws, renditions, etc.”

Mr. Hughes also provides a number of accomplishments of ARG: “We greatly assisted the restructuring of the ministries, focused the health and education effort, facilitated the organization of the presidential and parliamentary elections, helped develop a comprehensive counter narcotics strategy, developed a comprehensive agricultural strategy, served as a catalyst for an in-depth survey of Afghanistan’s mineral resources, developed a complete air transportation strategy, monitored road building progress, focused government priorities for major capital spending, developed a comprehensive energy strategy, prioritized and facilitated critical legal reforms, developed an in-depth approach for regaining control of the borders and customs revenues, worked with Office of Military Cooperation–Afghanistan (OMC-A) to develop a police training strategy, and helped coordinate the USG budget submission for Afghanistan to Congress.”

Although USAID respondents did not list specific achievements of ARG, several military officers provided useful observations. One officer who left in the summer of 2004 thought that in the first six months of ARG’s operations: “it would be pretty clear that the ARG contributed heavily to at least three aspects of reconstruction: the elections, Ariana airlines [Jack Bell had had extensive experience in the airlines industry] and the counter-narcotics effort.” Another officer singled out Doyle Peterson’s efforts at alternate livelihoods for special merit. Another mentioned efforts by ARG on reconciliation and detainee issues.

## **Conclusion**

The US government has lost the ability to capitalize on the “golden moments” which it did so effectively at the end of World War II. This ability will not be restored under the current structure of American foreign policy. Although this paper focuses on ARG’s relationship with USAID, the bureaucratic flaws of USAID are not unique to it.<sup>28</sup> Ambassador Komer himself indicated that bureaucratic features are a natural tendency in any institution: “[T]he institutional constraints discussed herein are by no means peculiar to our Vietnam experience. They are characteris-

tics inherent to a greater or lesser degree in the behavior patterns of large hierarchically organized institutions – private or public, civilian or military, American or foreign.”

The various criticisms of ARG by others – a lack of strategic direction, an inadequate Task of Responsibilities, a lack of expertise, etc. – and the criticisms by ARG of others – a lack of cooperation, bureaucratic red tape and the like – should not obscure the fact that there was a general consensus that the mission of ARG is an important one, that ARG has been at least partially successful and that an entity similar to ARG is necessary. There is less consensus as to what form that entity should take. It is significant that the two principal architects of the reformation of ARG are at opposite poles, with Mr. Hughes suggesting that ARG be given control over the reconstruction budget and Mr. Fine noting that giving ARG any sort of a budget would be a “terrible idea.”

Every bureaucracy needs an inspector general, ombudsman, internal affairs office, comptroller or similar function to monitor its performance. The relationship between the bureaucracy and that monitoring group is always strained at best, if the monitors are functioning correctly. ARG was unusual in organizational practice history in that it was established in large part to monitor the activities of unrelated entities. This assured that, so long as ARG’s mission was to police those other entities, it would not be co-opted by the bureaucratic imperatives of such entities, but it also inflated the friction between them. There was bound to be tension when ARG was introduced into the Embassy, but tension, despite the bureaucrat’s classic fear of it, can be beneficial if it is properly directed.<sup>29</sup>

The transition to a more placid and cooperative role may have reduced the tension level, but it leaves the original mission of ARG unfilled. The new role may or may not have improved the decisions of USAID, but it begs the question whether yet another bureaucratic structure needs to be introduced into the reconstruction progress. If ARG’s mission is limited to providing “new ideas” to USAID, the suggestion of some USAID respondents to merge ARG into USAID may bear consideration.

ARG’s record is mixed. Very few of the respondents believed it to be a failure, and the vast majority think that it is a useful model for future reformation, although many, both outside and inside ARG, believed that significant structural changes are necessary before it becomes a model for future nation building. Be that as it may, its success was enough for a much greater investment in money and personnel by State in creating IRMO. Whether the changes in its structure result in an improved form of ARG or is just the creation of another bureaucracy remains to be seen. The



transformation of ARG away from its role as inspector may have reduced tension but it may very well have stripped ARG of its most important role.

Whether or not the solution is to “send in the amateurs,” the continuing failings of all bureaucracies must be addressed. Colonel Rob, a wily Pennsylvanian with 27 years experience in the Army, identifies three crucial elements in the character of anyone who is going to be useful in post-conflict nation-building: “[Some people] have the right qualities: a genuine desire to help the Afghans succeed; common sense; and a sense of what was practical and realistic, given the environment in which we operated. Some others had none of these qualities, whereas others had the desire untempered by reality.” It would be wise for everyone involved in our current missions to recognize that no organization has a monopoly on such qualities.

QUESTIONNAIRE

Afghanistan Reconstruction Group (ARG)

1. With which agency of the reconstruction effort were you affiliated (check one)

ARG

Military

State Dept.

USAID

USAID Contractor

Other  (specify: \_\_\_\_\_)

2. What did you understand the role of ARG to be (please rank each applicable answer, with "1" being what you believed to be the most important function):

Team building (coordinating activities of different agencies and NGOs).

Inspection (reviewing the results of other agencies' reconstruction projects and programs)

Intelligence (serving as the eyes and ears of the Ambassador)

Advisory (providing outside advice to the Ambassador and/or the reconstruction program)

Expediting (using expertise and access to Ambassador and/or Washington to move process forward)

Initiating (introducing new ideas)

Other (please specify: \_\_\_\_\_)

3. What do you think the functions of the ARG SHOULD have been (please rank each answer, with "1" being the most important function):

Team building (coordinating activities of different agencies and NGOs)

Inspection (reviewing the results of other agencies' reconstruction projects and programs)

Intelligence (serving as the eyes and ears of the Ambassador)

Advisory (providing outside advice to the Ambassador and/or the reconstruction process)

Expediting (using expertise and access to Ambassador and/or Washington to move process forward)

Initiating (introducing new ideas)

Other (please specify: \_\_\_\_\_)

4. On a scale of 1 to 5 please rate the effectiveness of ARG, with "1" being the least effective and 5 being the most effective \_\_\_\_\_

5. Please explain why you gave ARG the rating you gave it in item 4.

\_\_\_\_\_  
\_\_\_\_\_

6. Please explain if your answer to 4 above was uniform across the full spectrum of ARG activities or if the effectiveness of ARG varied from person to person or subject matter to subject matter.

---

---

---

7. How could ARG's effectiveness have been improved?

- Bigger staff
- Giving ARG a budget which would have entitled it to implement its own projects
- Recruiting from public sector only
- Recruiting from private sector only
- Orientation before arrival in Kabul
- Other (please specify: \_\_\_\_\_)
- There is no way it could have been improved.

8. In what ways did ARG help the reconstruction process, if any?

---

9. In what ways did ARG hinder the reconstruction process, if any?

---

10. Is ARG a useful model for future reconstruction programs?

11. If you were not in ARG, how much contact did you regularly have with it (in rough percentage of your average work week)? %

12. Please indicate whether the following attributes of ARG were positive (indicate with a "+") or negative (indicate with a "-") or both positive and negative, depending on circumstances (indicate with a "0"):

- Recruited from outside the State Department and USAID
- Diverse backgrounds of personnel
- Each ARG member was empowered to approach his area of expertise the way he or she thought appropriate.
- Small number of ARG members
- Lack of budget for its own projects

## Endnotes

1 Col. Samuel Rob, the Staff Judge Advocate for Combined Forces Command–Afghanistan (CFC-A), offered some general observations which succinctly summarized the reconstruction problems in Afghanistan:

- too many “rice bowl” issues; never a sense that consensus had been achieved for any course of action. [COL Rob describes “rice bowl issues” as ones where “agencies/organizations/etc. are more focused on the specific implications/effects for their agency/organization of a plan or proposal, rather than looking broadly at the proposal/plan and the greater good or are very jealous of what they view as any possible encroachment on their territory/area of expertise/etc. by another agency/organization. An example would be an agency working against an idea that, while beneficial to the nation as a whole, reduced the influence of that particular agency. Another example would be a group or organization that becomes primarily concerned with perpetuating itself rather than solving the problem for which the group/organization was created in the first place.”]
- [I] don’t think the Afghans were brought into the fold on many things, so many projects/initiatives never had “buy-in” from the Afghans themselves
- ARG’s influence/effect didn’t seem to extend much beyond Kabul. Even if initiatives [were] planned for the countryside, [they were] difficult to monitor/inspect
- [I] never understood how things were prioritized, if at all. For example, basic needs (medical care, economic initiatives, judicial reform) seemed on equal footing with women’s rights which, while important, has no chance to succeed if basic individual and societal needs are not first met.
- the overarching strategy for recovery was never clearly articulated, such that many efforts were uncoordinated and sometimes at cross-purposes.
- personnel turbulence - too many people coming and going. Continual reinvention of the wheel as new people had to be brought up to speed on projects, etc.
- poor recordkeeping -- better records would have given greater visibility over projects/initiatives and contributed to better planning.”

2 Rand Corporation, August 1972; available on the internet at [www.rand.org/pubs/reports/R967](http://www.rand.org/pubs/reports/R967).

3 Ibid p vi

4 Ibid p. 20

5 Ibid. p. 20

6 Ibid. p. 17

7 Ibid p. 65

8 Ibid p. 76

9 Ibid p. 67

10 Legal reform, in particular, is difficult for outsiders to assist in bringing about. A legal system is far more closely linked to a country’s culture than any other area of development. Not only is a country’s law shaped by its culture, but its culture is shaped by its laws. Any country, therefore, will find it difficult to embrace reforms proposed by outsiders. This is a worldwide phenomenon: no one is disturbed if his doctor is a foreigner, so long as he knows what he’s doing, but imagine the backlash if one goes to court and finds

that his judge has been imported! cf. *Law, Culture, and Ritual: Disputing Systems in Cross-Cultural Context* by Oscar G. Chase (NYU Press, 2006).

Add to this the difficulties unique to Afghanistan, a country where three, often contradictory, legal traditions operate side by side (tribal law, Shari'a (Islamic law) and civil law, which is based on the Napoleonic Code as Islamicized by the Ottoman Empire in 1850). Afghanistan's judiciary consists almost entirely of religious figures, many of whom have training in Shari'a, but almost none of whom have training in constitutional or statutory law. Add to this a country virtually devoid of lawyers, having inadequate and bifurcated law schools, which teach either Shari'a or civil law but not both, a statutory scheme which hasn't been amended in nearly forty years (except for Communist or Taliban laws which only made the legal code worse), a poorly trained police force, and nearly all prisons in the country wrecked and one finds precious little law to reform. What's more, the ham-fisted efforts of an international organization in 2003 created a sense of distrust among the few jurists in the country: anxious to have a banking law in place, this organization muscled an English language version of the law through the cabinet without translating the law into Dari or giving the cabinet the opportunity to understand the law they were told to approve. This blatant imposition of a law on a proud people like the Afghans created a backlash which was one of the reasons, in addition to lack of capacity, why the Taqin, the legislative drafting body within the Ministry of Justice, was so slow to act during the last several years.

11 To name just two instances of such dedication:

ARG assisted the Ministry of Culture in mediating a dispute, between the embedded State Department advisor at the Bamiyan PRT and the International Narcotics and Law Enforcement Division (INL) of the State Department, over the placement of a police training camp in a culturally sensitive location. After settlement of the dispute by the Minister, Robert Jimenez, a retired Army colonel then nearing his second retirement after a career at USAID, told me that if I could find a list of important archeological sites in Afghanistan, he would create a database against which all future projects would be checked to prevent desecration of such sites. Nancy Dupree, a well known anthropologist, supplied me with a comprehensive text running to well over 1000 pages long and listing hundreds of sites. Bob cheerfully set about creating the database.

Shinwari, the Chief Justice of Afghanistan, was chosen because of his prominence as a Muslim cleric, not because of his judicial demeanor or any knowledge of the law beyond Shari'a (and even his credentials in Shari'a were questioned by the Parliament when it rejected his re-nomination to the post by President Karzai in late May of 2006). He regularly issues fatwas of a reactionary nature, such as banning women from appearing on television or ordering the removal of a presidential candidate from the ballot because of blasphemous remarks (the candidate had questioned the equity of the ease with which a man could divorce his wife). Phyllis Cox, the country director of a USAID contractor specializing in legal reform, on her own initiative, began to spend several hours a week talking to Shinwari, mentoring him in the duties of a Chief Justice. It didn't stop Shinwari's fatwas but a trust grew up which was so strong that the Chief Justice asked President Karzai to give Ms. Cox a medal.

12 Since the topic of this paper is only tangentially a critique of USAID, I will mention just a few anecdotes to illustrate how Ambassador Komer's list of bureaucratic attributes are observable at USAID:

- A USAID officer told an ARG member that he didn't like working for Republican Administrations because they demanded an accounting of where the money went and "they think the Ambassador is in charge of the embassy," instead of a more limited role of "cutting ribbons and holding parties."
- Although the Bonn Agreement allocating reconstruction sectors assigned legal reform to Italy, USAID refused to cooperate with the Italian Justice Project, greatly reducing the effectiveness of the Italian efforts.
- When the ARG health care advisor saw the plans for a model clinic, over 400 of which were scheduled to be built around the country, he noticed that there was only one waiting room for both men and women, which is unacceptable in a Muslim country. The USAID project manager was surprised when this was pointed out. "They worked just fine in Colombia," he said.
- Although the military had a truly world class cadre of lawyers, including two sitting judges, a former Attorney General of the State of Delaware, an Assistant Attorney General of the State of Minnesota, prominent prosecutors and career JAG officers at the top of their game, many of whom had extensive nation building experience, USAID generally left them out of decisions involving legal reform.
- Early in 2002, USAID gave the Shari'a School a \$7,000 computer, which was set up in the Dean's reception room. It was never connected, no training was provided and, despite promises (according to the Dean) that USAID would return, as of February 2005, it never had. The Shari'a School, located in the former medical school at the University of Kabul, resembled a construction site: most classrooms were just raw concrete and missing windows throughout the building meant that faculty and students wore overcoats all day during the all winter. Every meeting with the Dean began with an angry attack on USAID and the \$7,000 computer, an embarrassing presence which sat in the center of the room like a turd on the living room rug. It offended the Dean's common sense in addition to serving as a constant reminder of a broken promise
- A description of the problems facing USAID in Afghanistan, and its inability to deal with them may be found in "A Rebuilding Plan Full of Cracks" by Joe Stephen and David B. Ottaway, *The Washington Post*, November 20, 2005, page 1. Reprinted in the *European Wall Street Journal*, November 24, 2005. See also "The Trouble with USAID" by Roger Bate, *The American Interest*, Vol. 1, No. 4 (Summer 2006).

13 A common figure cited even by USAID officers was that 50% of all funds allocated to a USAID project never leave the United States, being allocated to overhead expenses of a small number of USAID contractors and subcontractors who are awarded the vast majority of foreign aid contracts. While I have no citations to support this statistic, I am aware of numerous examples of USAID rejecting a less expensive project for a more costly alternative of equal or lesser quality:

- It rejected a \$2,000,000 bid to operate a hospital in Kabul made by a non profit medical organization with a proven track record in Afghanistan. Instead it accepted a bid of nearly \$20,000,000 for the same services from one of its regular contractors.

The grounds for rejecting the lower bid was that the non profit organization gained an unfair advantage by asking the ARG health care advisor to review the bid because it had never bid for government work before.

– The State of North Carolina offered me, without a license fee, its computerized registration system to serve as Afghanistan’s land title registration system. This system has proven so effective that many other states have licensed it for their own needs. A USAID contractor rejected it without even examining the system, preferring to spend money to develop a similar system on its own.

– The Center for International Management Education, (“CIME”), a non profit NGO, in collaboration with the American Bar Association, recruited over 100 prominent American, European and Islamic lawyers divided into about 20 teams to review Afghanistan’s existing commercial laws, to prepare proposals to modernize the laws, to vet the proposed reforms with Islamic scholars and then to fly to Kabul to explain those proposals to members of the Afghan government. This program had proven very effective in other countries. The lawyers served pro bono and had already had significant success in Afghanistan, but the program had exhausted private funds and needed only about \$400,000 in travel expenses to complete the program. One of the two USAID officers working on legal projects rejected this request on the grounds that Shari’a was sufficient for all commercial transactions, a statement which is accurate neither as a matter of theory nor practice, where even Iran has a body of law more modern than Afghanistan’s. The contractor for the other USAID legal project, for considerably more money, hired a USAID contractor who downloaded commercial statutes from other countries and offered them to the government despite their inappropriateness for the Afghan legal system.

14 I was appointed Senior Legal Advisor in October 2003 but wasn’t cleared for arrival until the middle of February 2004.

15 ARG’s first Private Investment Advisor, William McCampbell, an energetic and effective lawyer from Washington, D.C., became the ARG’s first casualty, when he collapsed at the Embassy and later died of a brain tumor. Later casualties included General Maney and Senior Agriculture Advisor Doyle Peterson, who were wounded when an Improvised Explosive Device destroyed their vehicle outside of Kabul.

16 An example of this approach was Said Mirzad, the Senior Natural Resource Advisor. Dr. Mirzad, an Afghan-American who was the former Deputy Minister of Mines under the King of Afghanistan, is a learned and accomplished man whose life could have filled a library of adventure books before he joined the US Geological Survey. With the assistance of the USGS, he created a model program for the responsible exploitation of Afghanistan’s natural resources while building administrative capacity within the Ministry of Mines.

17 Economics and law were the two sectors most in need of traffic cops, with a large number of participants. Legal reform involves six separate areas of reform including legal education, courts, legislation, police, corrections and public awareness and they all had to be furthered simultaneously in order to make any progress. . USAID had two separate programs relating to legal development -- a legal reform program and an economic program which was involved in commercial laws – each run by a different contractor with little or no coordination between the two. The military had an extraordinarily competent

array of legal and civil affairs talent who were always ready to fill any gap, from teaching at the law school to providing liaison with the Corrections Department. The State Department's INL was involved, together with the British and the UN in narcotics laws and, together with the German Embassy, police training. In addition, many international agencies were involved in legal reform including the IMF, the World Bank and the United Nations. Legal issues also cropped up in a large number of ministries and NGOs. By far, the most effective work was done by independent, poorly funded non-profit entities such as the International Legal Foundation, which provided the only training and staffing of defense attorneys in the country and CIME – some of whose lawyers came to Afghanistan at their own expense to assist when USAID refused to fund them. Overseeing the entire sector was the Italian government which had established the Italian Justice Project. Some areas of reform brought me into regular contact with other governments which handled a one of the six areas mentioned above, including the embassies of Germany (which was involved in police training), the United Kingdom (which ran the counter narcotics program) and Canada (which endeavored to fund specific programs in the justice area). In addition, the paucity of civilian lawyers at the Embassy required me to serve as legal counsel to a wide variety of matters. . The State Department's Political Economic Section regularly faced problems for which legal advice was necessary. The military needed a legal advisor on its reconciliation program and several times, teams from Washington arrived to deal with various prison issues and needed civilian legal assistance. Occasional crises also developed such as the time when a Minister who had had his fill of NGOs ordered over 3,000 NGOs out of the country and proposed a draconian law regulating them.

18 Projects ranged from long term multi-agency projects such as the merger of Shari'a Law School and the Civil Law School into a unified law school, presiding over a bottom up review of legal reform and serving as the legal advisor to a joint CFC/State Department reconciliation campaign to very short term projects such as inspecting a prison for its suitability for holding drug lords, finding a way to break a corrupt contract signed by a government minister and determining why one tribe in Afghanistan had never grown opium (the soil in its tribal region was unsuitable).

19 In their response to the questionnaire, several members both within and without ARG singled out the tactics of the ARG Health Care Advisor for criticism, so special note should be made of his activities. After the Ambassador himself and the Afghan-Americans serving at the Embassy who provide a crucial bridge between Western concepts of development and Afghan culture, Kaivon Saleh had the most impressive resume of anyone in the Embassy. The son of an American mother of German extraction and an Iranian father who was one of the great figures of Iranian history, Dr. Saleh was the last Minister of Health under the Shah of Iran, succeeding his father who created a system of rural health care which is still the model for developing nations around the world. After the fall of the Shah, Dr. Saleh spent six years designing hospitals for Kaiser Permanente before spending 14 years supervising hospital construction for USAID throughout the Middle East.

Dr. Saleh was very committed to the Afghan people, often returning to the Embassy in tears after touring a substandard hospital. As a native Farsi speaker (a language closely related to Dari), Dr. Saleh developed a network of contacts within the Afghan government, most significantly in the Ministry of Health. Relations between USAID and the



Ministry of Health had already broken down before Dr. Saleh arrived and the Minister became an eager ally of Dr. Saleh. The Ministry was angry at USAID because of its unwillingness to listen to them as well as the slow rate and poor quality of construction of clinics. The Minister, the only female general in the Afghan army and a medical doctor trained in Moscow, would feed Dr. Saleh information not available to USAID, which had received inaccurate reports from its contractors.

Rather than report these inaccuracies to the USAID administrators, Dr. Saleh would wait until USAID presented the inaccurate information to the Ambassador at daily briefings and would then embarrass the USAID briefing officer by contradicting him, presenting photographs of concrete slabs or mud huts which had just been billed as fully completed and operating modern buildings. This understandably caused a large degree of friction between ARG and USAID.

Dr. Saleh was not just being provocative by doing this, however; his theory was that the way to make a bureaucracy perform properly is to increase the penalty for poor performance. By creating tension at the Ambassador to USAID level, he expected the tension to evolve into increased discipline at the USAID to contractor level. Taking his information to USAID, on the other hand, would only work so long as he was there to give it to them. His tactics may have been disruptive, as even some ARG members have alleged, but no one challenged his effectiveness. What's more, the distrust between ARG and the rest of the Embassy predated Dr. Saleh's arrival in Kabul and appears to have intensified after his departure. Another ARG advisor recruited from another government department believes that "controversy would have erupted one way or the other."

In the legal sector during my tenure, relations between ARG and other elements of the reconstruction effort were generally cordial and cooperative and even at their worst were never less than proper, although my presence was not welcomed by some and like an ARG advisor in a different sector, I found that "ARG was frozen out of some decisions or operations unless individual ARG members "forced" their way into situations/meetings."

The only outright friction in the legal sector was caused by an honest policy dispute: the Afghan Constitution required a court reorganization law to be enacted by December 31, 2004. Throughout the fall, a team of Afghan and American lawyers, including representatives from USAID, its primary legal contractor, the Judge Advocate General Staff, President Karzai's office, ARG and the University of Kabul, among others, drafted such a law. In the beginning of November, the Country Director for the USAID contractor was replaced by a new Director who felt that the Afghan courts should take the initiative in drafting the law. Despite the judiciary's near total absence of capacity in legislative drafting or even basic legal concepts (other than Shari'a), this was a reasonable suggestion because it meant that the judiciary would "buy in" to the new structure, but it would mean a long delay in enacting the law, thereby ignoring the plain language of the Constitution to have the law in place by the end of the year. I felt very strongly that we should push the deadline as a means of demonstrating the importance of obeying the express terms of the Constitution. Any deficiencies in the act could always be remedied by later amendment. I found the willingness of USAID and its contractor to encourage the Afghan government to ignore an important mandate in its new Constitution disturbing, while they were no doubt equally horrified by my willingness to impose a law on the judiciary which it

hadn't drafted. This conflict was settled peacefully when, on the theory that it was better to misinterpret the Constitution than ignore it, I discussed the issue with the counsel to President Karzai and he was willing to give an opinion that the Constitution required that drafting and negotiations on the court law begin, rather than be completed, by December 31, 2004.

20 This cuts both ways. Experience can sometimes lead to a lack of awareness of the uniqueness of a particular culture and can also blind one to alternatives to the expert's familiar way of doing things. No ARG member proposed an inappropriate building because it had worked well in Colombia, after all. In addition, as originally conceived, ARG was intended to be less focused on development per se than on (i) addressing the bureaucratic flaws in the reconstruction process and (ii) encouraging private investment and free market solutions, neither of which missions required a background in development and both of which would, in fact, have been seriously compromised by a mindset locked into government development solutions. Finally, the charge reveals more an ignorance of ARG's capabilities by those making the charge than anything approaching reality. Dr. Saleh had spent more time working on USAID health care projects than any one in the country and, unlike most of the USAID staff and contractors, had concentrated his career with USAID in Islamic countries, so he was far more familiar with Muslim culture than anyone at USAID. General Maney arrived in Kabul with post-conflict nation-building experience in three other countries. Doyle Peterson has spent a lifetime on agricultural projects in Central Asia. Jane Wiegand, the Senior Privatization Advisor, has a successful legal practice in the Gulf States and knew a host of people throughout the Muslim world. Everyone in ARG was chosen for a set of qualities which were perceived to be needed.

I saw only one example where a lack of experience caused a serious problem. Unaware, perhaps, of the role of corruption as a widely accepted system of privatized welfare, an ARG advisor pressured the Afghan government to prosecute a group of government officials for corruption. After charges were brought, the court promptly released the defendants for lack of evidence and immediately sentenced to prison two innocent officials closely identified with the ARG advisor. Although the advisor was successful in obtaining their release, the court's message was unmistakable.

21 For my part, I saw very little evidence of arrogance in ARG in its first year of operation (to which the proper response would be, I suppose, "you wouldn't, would you?"), but a later ARG advisor reported that "it seemed as if the ARG had a rather snobbish attitude regarding the private sector. Most were higher ups from private companies who brought a wealth of experience in how to run a business but very little in the area of governmental operations or organization."

22 From a USAID official:

"An ARG team member made (for what I – even a year later - cannot find any basis for in rationality) a proposal that would have stopped the major USAID economic growth procurements in their tracks about a year ago and defended his proposal stubbornly. If that view had been accepted, the economic activities of USAID. . . . would have shut down. It is important on the ground to be careful in ways this proposal was not. Numerous USAID and other ARG members heard his presentation on these matters, and USAID finally went to the Minister of Finance to be sure that the ARG team member was wrong – a total waste of time).

In answering question 2 of the questionnaire as to what he thought the purpose of ARG was, this individual replied: "Ego gratification of certain ARG team members who did not understand development and were trying to take major technical decisions and run Afghanistan's USAID funded activities at the same time they were learning how to carry out development."

This from an employee of DFID, the British aid agency:

"The ARG representatives I worked with were ill-prepared for the environment they were in. They demonstrated a "bully" mentality and made no effort to work with other agencies or entities. Even the few who had valuable expertise did not have the experience of working in a post-conflict environment. Some were competent, but not prepared for the post-conflict situation. Others were incompetent, and not prepared for the post-conflict situation. Others were just plain mean. . . . I only experienced unreasonable expectations and bullying techniques."

23 Mentoring relationships, and establishing friendships with Afghans are extraordinarily effective reconstruction tools, tools which are all too often ignored. More than a year after I returned home, I continue to receive e-mails containing highly detailed information about a charitable organization serving as a front for terrorist activity. My source, acting at great risk to himself, is the friend of a friend. I dutifully send this information to the FBI, who just as dutifully files the information in the same warehouse where the Ark of Covenant is stored. Nearly six months after I sent the first report to the FBI, the Bureau has taken no action.

24 This is of more than passing interest and may very well be an example of the "for want of a nail" syndrome. The Italians took their duties very seriously. The first director of the Italian Justice Project was Giovanni DiGennaro, one of the great legal heroes of the twentieth century. Hero of the Italian Resistance movement in World War II, kidnapped by the Red Brigades, successful prosecutor of the Red Brigades and the man who almost single-handedly broke the back of the Mafia in Italy, Judge DiGennaro focused on criminal law. His successor, Ambassador Jolanda Brunetti, has had a long and successful diplomatic career. She has been the Italian Ambassador to the Ukraine where she worked closely with U.S. Ambassador Carlos Pascual (later the Coordinator of the State Department's Office of Reconstruction and Stabilization), who has great regard for her abilities. The refusal of USAID to cooperate with the Italian Justice Project meant that the efforts of IJP were severely handicapped through no fault of its own. This in turn led to international criticism of the effectiveness of the Italians and became a major embarrassment to the Berlusconi government, which was defeated by the razor slim margin of 22,000 votes in the 2006 elections. The new government promptly removed its troops from Iraq.

25 Many respondents, including some from ARG, who favored using ARG as a model also thought that ARG needs to be restructured to make it more effective.

26 The two unaffiliated persons who replied show the disparity among responses. One, the co-founder of an unaffiliated non-profit NGO, gave the ARG its only "5" rating based upon the ARG's efforts to link the NGO with alternate livelihood experts at USAID and ARG. The other, an embedded advisor in one of the ministries who worked for the British government, gave ARG one of the three lowest ("1") ratings ARG received and made the harsh remarks about ARG quoted above.

27 By category of respondent (ignoring those who did not answer or wrote “0” indicating that the attribute was both positive and negative depending on circumstances) the results were as follows (in the chart below, “7/12+ 2/12-”, for instance, means that seven out of 12 respondents thought this was a positive attribute, 2 thought it was not and the rest either didn’t answer the question or answered with a “0”):

	Mil	ARG	DOS	AID	AID contractors	Other
<b>Outside Recruitment</b>	10/10+	10/12+	2/4+	2/5+ 2/5-	1/2+	1/2+ 1/2-
<b>Diverse</b>	10/10+	12/12+	4/4+	5/5+	1/2+	2/2+
<b>Empower</b>	7/10+ 1/10-	7/12+ 2/12-	2/4+	1/5+ 2/5-		1/2+ 1/2-
<b>Small number</b>	5/10+ 2/10-	9/12+ 1/12-	2/4+	5/5+	1/2+	1/2-
<b>No budget</b>	1/10+ 9/10-	2/12+ 7/12-	3/4-	4/5+ 1/5-	1/2+ 1/2-	2/2-

28 In an article called “Cop Out: Why Afghanistan Has No Police” in The Weekly Standard of July 17, 2006 (Vol. 11, issue 41), Vance Serchuk reports how a bureaucratic battle between the Department of Defense and INL has resulted in a poorly trained police force.

29 It is my personal belief that the current biased tendencies of the American media do far more harm to the causes, ideals and political factions which they favor than it does to those which they instinctively attack. By ignoring or underplaying the flaws in a favored subject, the media encourages the entropy inherent in any neglected flaw. USAID falls into this category because of the general willingness by the press to treat it favorable whether or not it has performed acceptably.

# **Developing Weapons of Mass Construction: The Role of Provincial Reconstruction Teams in Stabilization Operations**

**Roberto Bran—Department of State**

## **Introduction**

More than three years into the war in Iraq and almost five years since the start of the Global War on Terror, the United States government remains imperfectly configured to undertake nation-building and stabilization operations of the scale required to achieve our strategic objectives. Neither the US military nor the civilian federal agencies have the appropriate mixture of security, reconstruction, and capacity-building capabilities to execute our nation's mission, and this gap appears to be becoming no smaller than it was when America first entered into a new world of expeditionary operations. With organizational cultures and bureaucratic inertia resisting the doctrinal and structural reforms needed to permanently improve the system, the experience of non-traditional methods of stabilization and security assistance become even more important in order to improve and refine future nation-building operations. This paper will examine the emergence of Provincial Reconstruction Teams (PRT) as an instrument of stabilization in Afghanistan and Iraq; determine the essential functions necessary to support nation-building operations; and recommend modifications to the current structure in order to field more effective reconstruction tools in the future.

## **Vietnam**

An examination of PRTs begins with its ancestral experience in the Vietnam War. Although PRTs *per se* were not employed during that conflict, it is important to note that the US government implemented similar programs that would serve as inspiration for Provincial Reconstruction Teams. The first was the Civil Operations and Rural Development Support (CORDS), formed in 1967, which placed the disjointed and ineffective civilian pacification programs under military control. Historians differ on the efficacy of the CORDS program, but it is commonly believed to have been an improvement over the disconnected system that it replaced.

The second precedent lies with the US Marine Corps' Combined Action Program (CAP) that sought to win the "hearts and minds" of the Vietnamese, one village at a time. CAP units essentially paired US Marine rifle squads with Vietnamese Popular Force platoons, and embedded them within individual villages

throughout Vietnam to become what Jim DeGuid called, “Peace Corps Volunteers with guns.” Staffed completely with volunteers, the Marine Corps provided CAP personnel with rudimentary language and cultural training, and deployed them to stabilize the countryside. Like the Peace Corps, CAP volunteers lacked any formal training in some of the more nuanced technical skills, relying instead upon youthful energy and determination to overcome the problems they would confront. Unfortunately, the CAP was purely a function of Marine Corps imagination; even the US Army refused to conduct similar experiments of its own. It lacked participation from key civilian agencies that have the technical expertise and experience necessary to conducting complex nation-building activities. Perhaps more importantly, the Combined Action Program was unending. Despite significant anecdotal evidence that the CAP was achieving positive results, when the Vietnam War ended, the Marines buried the program and the experiment came to an unjustly premature end as the military redefined itself into an organization prepared for and capable of fighting not the unconventional war it has just experienced, but the conventional conflicts of maneuver warfare.

## **Afghanistan**

During the initial phases of Operation ENDURING FREEDOM, the Coalition assembled civil affairs groups named Coalition Humanitarian Liaison Cells (“chiclets”) and deployed them into key cities and population centers, where they were responsible for leading the military’s relief effort. The concept worked well during the initial phase, but after the Coalition quickly toppled the Taliban regime, military planners sought to leverage the civil-military capabilities provided by the “chiclets” during the Phase IV stabilization operations. Because the international community’s military footprint was relatively limited (less than 30,000 troops in the Coalition and International Security Assistance Force [ISAF] combined), the refined concept sought to extend the stabilizing “ISAF effect” into provinces where the Coalition would otherwise have no military presence. Originally named Joint Regional Teams, the PRTs reported through a Combined Joint Civil Military Operations Task Force (CJCMOTF) and were responsible for expanding the influence of the Islamic Transitional Government of Afghanistan (ITGA), facilitating the conditions for reconstruction, and interfacing with the provincial and local political leadership.

The Coalition initially fielded four PRTs in the first year, with plans to establish a total of eight. But soon after assuming command of Combined Forces Command – Afghanistan in the fall of 2003, Lieutenant-General David W. Barno made PRT expansion one of the “five pillars” of his campaign plan. Additionally, as NATO has increasingly assumed responsibility for military operations in

Afghanistan, ISAF has established Provincial Reconstruction Teams throughout the country. As of January 2006, there were twenty-one PRTs in Afghanistan, and anecdotal evidence seems to suggest that they have made a positive contribution in multinational nation-building and stabilization operations.

Though representing a step forward in the nation's organization for stabilization and reconstruction operations, PRTs in Afghanistan do not go far enough: almost exclusively staffed by military personnel, they lack much of the interagency and civilian expertise necessary to implement nation-building's complex reforms. Each PRT is commanded by a civil affairs branch Lieutenant Colonel, and consists of approximately 80 to 120 personnel, although some PRTs (especially the European commanded units) have considerably more. Most of these personnel consist of soldiers conducting force protection, but reconstruction and capacity-building functions are also contributed by civil affairs teams, civil military operations cells, and US Army Corps of Engineers units. The civilian presence is limited to less than a handful of personnel: typically, a Field Program Officer contracted to the US Agency for International Development, and a single State Department Foreign Service Officer; a few PRTs have an officer from the US Department of Agriculture, but the civilian expertise in the PRTs is generally lacking. The Afghan PRTs do possess a single representative from the Government of Afghanistan's Ministry of the Interior (the host nation proponent agency for the PRTs), and this facilitates the PRT's interaction with the local population and government officials. But some PRTs are still not well integrated into the larger Coalition operations in their area, and some PRT personnel have claimed that maneuver commanders do not take their activities into account, thereby failing to supplement their kinetic operations with the PRT's significant potential to contribute non-lethal effects (and sometimes working against such effects).

## **Iraq**

Still (although no metrics exist to gauge how well the PRTs have functioned in Afghanistan), significant anecdotal evidence suggests they are contributing positive effects, and so the US Government chose to field PRTs in Iraq soon after Ambassador Zalmay Khalilzad assumed duties in Baghdad. On November 14, 2003, at the inauguration of the Ninewa PRT, Condoleezza Rice announced that two other PRTs would be formed that month, and that a total of 16 would be fielded by the summer of 2006. The announcement marked the first public commitment to PRT expansion as a method for improving stability in Iraq, but the implementation has followed slowly: as of the summer of 2006, only six PRTs have been fielded, although the Iraqi Reconstruction Management Office fully intends to generate more. One reason for the delay in implementation is that, unlike in Afghanistan,

IRMO has decided to build PRTs under a civilian-led model in Iraq. This decision, compounded by a general unwillingness of career Foreign Service Officers to commit to the program, has meant that positions are being filled by federal employees from across the spectrum of government agencies as well as private sector civilians volunteering for the program.

Each Iraqi PRT is led by a PRT Leader and a Deputy PRT Leader (both coded for GS-15, although it appears that only the primary is a career State Department employee), and consists of about 80-120 personnel, including force protection and host nation employees. The security has been a point of contention within the State/Defense interagency squabble, and some State Department employees have publicly claimed that they were being ordered into Iraq without sufficient protection from the military; I have been unable to find evidence, however, of a single PRT that does not possess Coalition forces for security. Beneath the leadership, IRMO has designed a number of supporting positions, each of which are expected to contribute technical expertise to the nation-building program. These positions include: the **Provincial Program Manager**, who is responsible for overseeing the coordination of US Government-funded reconstruction and development projects in their respective province; the **Provincial Action Officer**, who is responsible for interfacing with the local administrative, civil society, and political leadership and develops the local institutions required to stabilize the region (roughly the equivalent of what Civil Affairs teams provide for Army commanders); and the **Public Diplomacy Officer**, charged with overseeing the strategic communications plan for the PRT (roughly equivalent to an Information Operations specialist for the military). IRMO has also established a number of highly specialized technical advisors, including a **Rule of Law Coordinator**, **Agricultural Advisor** and an **International Development Advisor**, each of whom have extensive experience in their fields and are responsible for developing those functions within the host nation. Additionally, just as in Afghanistan, a USAID Field Program Officer has been assigned to each PRT and is responsible for overseeing the implementation of USAID projects within their region.

What value the PRTs in Iraq have remains to be seen, and will likely emerge only slowly and anecdotally. Some military commanders have already complained that the PRTs in their sector lack the resources needed to effectively contribute to an effects-based counterinsurgency and reconstruction plan. While PRTs are designed to provide unity of effort, it is unclear how well the dueling chains of command will be mutually supporting; it is entirely likely that interagency squabbles might further reduce the effectiveness of the PRT. Still, they have the potential to contribute non-lethal effects and commanders in the neighborhood might be able to make great use of their potential in their sector.



## **Functions of the PRT**

It lies beyond the scope of this paper to determine whether or not PRTs can or should become a doctrinal component of the US government's configuration for nation-building and counterinsurgency style operations. But any discussion about the future of PRTs should begin by defining what capabilities the government seeks to build in preparation for a future conflict. While these functions are subject to considerable debate, I am proposing five basic functions that PRTs should be capable of undertaking to provide measurable support to US and international reconstruction efforts abroad. These functions are:

1. Security
2. Aid and Development
3. Local Government / Capacity-Building
4. Intelligence / Information
5. Public Diplomacy

### *Security*

By deliberate design, a PRT's security footprint is insufficient to conduct intensive counterinsurgency operations; this task largely belongs to Coalition brigade and battalion commanders, and it is probably best if these tasks remain separate. PRTs typically possess only enough security capacity to provide force protection for the fixed base, as well as movement security for PRT personnel leaving the sanctuary to meet with local officials, survey development projects, or otherwise conduct their missions. Still, the PRT is able to improve security in its surrounding area through a variety of means. First, it can exercise reach-back capability to utilize quick-reaction superior firepower—such as howitzers, rockets, or USAF air strikes—in order to overwhelm massing enemy forces in an emergency. When armed clashes broke out in western Afghanistan in early 2004, for example, the Herat PRT's ability to leverage a US Air Force "show of force" is widely believed to have prevented escalation and forced a ceasefire between Ishmael Khan and Amanullah Khan. Likewise, it can serve as a forward operating base, command and control node, or logistical element for follow-on Coalition forces if the latter find it necessary to quickly expand their presence in a given area or region; in Afghanistan, Coalition battalions frequently use logistical support from the PRT, and some are in fact co-located out of the same fire bases. Simply by being tied into the larger picture of military operations, the PRT can enhance local security

for NGOs and implementing partners (IP) by keeping the Coalition informed of activities in their surrounding area, and by establishing a hotline that would enable aid workers to report their movements or send a distress signal to the PRT in cases of emergency. Generally-speaking, no more than a single infantry company is needed to secure a PRT, and this can shrink to a single platoon if host nation support is forthcoming.

### *Aid and Development*

This function relates to the only physically verifiable operations of the PRT: its mission to conduct or oversee the construction of physical infrastructure projects. Different environments will require that this function be implemented differently. For example, in a Bosnia or Kosovo, where the security situation is permissible, the PRTs mission here may primarily be supervisory and coordination-based, i.e., to interface with local companies or NGOs who are building in the area, and to avoid duplicating projects by participating in development councils. In a place such as Afghanistan, however, the security situation is far less benign, yet not so severe that NGOs are incapable of functioning throughout at least significant portions of the country; in these types of situation, NGO aid will be less forthcoming and the PRT may have to jumpstart the reconstruction project with a larger budget and directly hiring implement partners who are capable of building the wells, roads, schools, government buildings, and other infrastructure needed to develop the host nation. Finally, in a location such as certain provinces of Iraq, an insurgency might be so intense that NGOs will not operate, and the only development that is occurring must be generated by the PRT itself; in these instances, not only must the PRT have a tremendously large and flexible budget, but it must be empowered to ensure that the implementing partners (which would include government agencies, such as the US Army Corps of Engineers) are integrated into the PRT's organization itself. Locating the expertise needed for this function is a different matter: America is filled with construction management officials who have the technical expertise to oversee multi-million dollar projects, but leveraging them into the PRT in a timely manner might be a different issue. The Afghan model leverages Civil Affairs officers (some of whom, as Reservists, work in related fields during their civilian lives), while the Iraq model uses the Provincial Program Manager drawn from private sector volunteers.

### *Local Government / Capacity-building*

Because stabilization operations—by definition—are far more likely to occur in developing nations than in the industrialized world, it is quite likely that enhancing security and providing aid and development will not be sufficient to establish

the conditions for enduring security in the host nation. In most cases, the local and national institutions are not sufficiently developed to allow financial expenditures or raids against destabilizing organization to be sustained. For this reason, I am recommending that PRTs have a resident function to develop the capacity of local and provincial level institutions during stabilization operations. This function is perhaps its most robust, and most difficult to procure from a personnel standpoint. For example, while Naval Construction Battalions or US Army Corps of Engineers units are quite capable of building roads, airstrips, or schools, they do not possess the capability to administer a transportation system, an airline industry, or an education district—it is the ability to develop those functions that this line of operations seeks to provide. The Afghan PRTs are notably lacking in this capability, relying almost exclusively upon the Civil Affairs teams that a combat commander would have available even if a PRT were not present. The Iraqi PRTs—with the Provincial Action Officer, Rule of Law Coordinator, Agricultural Advisor, and International Development Advisor in each province—have much larger degrees of this capability, and stand as a potential model for future PRTs in international conflicts and post-conflict environments. The challenge in providing this function, of course, comes from the US government's limited ability to develop this kind of expertise, although my panel colleagues Kris Alexander and Tom Berner are both presenting useful models on how the PRT might be able to procure such talent, and it is important to note that in some environments, the PRT may be responsible (at least initially) for more than simply developing the governing capacity of the host nation—in conflicts where the local infrastructure is completely absent, it may be responsible for directly administering local governmental functions until the host nation can develop it.

### *Intelligence / Information-sharing*

Historically, reconstruction organizations have preferred to remain distinctly separate from intelligence operatives. This barrier is usually maintained because relief and development workers prefer to be viewed as benevolent and neutral during armed conflicts, and because political conditions are not acceptable to the distribution of humanitarian relief. (It is important to note, however, that reconstruction and development do not strictly belong under the rubric of humanitarian relief). Nonetheless, even a casual glance at the PRT's functions demonstrates that its membership will be in constant and continuous contact with local and provincial leadership; as the PRT conducts and provides development for the host nation, it will invariably cause local and provincial leaders to offer intelligence to their PRT counterparts. Often this will be part of a confidence-building test on the part of the local leaders, but it will also be symptomatic of the friendship and mutually satisfying bond that will develop between both parties. While the PRT probably

does not need fusion-type capability, it can and probably should have an analyst who can debrief the various members of the PRT when they return from meetings with their host nation counterparts, compile their information, and package it to a higher headquarters intelligence center for all-source analysis. Moreover, even when the information does not support a military objective, the PRT will become the best source for information political-military assessments of its respective area of operation. Military units that will be operating in or near its territory will quickly find that the PRT is the single best source for information about local and provincial political leaders, including how they might react to a particular initiative and, with a permanent relationship with those leaders, can more easily influence their behavior.

### *Public Diplomacy*

The final function is one that has become particularly important with the evolution of modern warfare. Formerly the domain of public affairs, mass media and the nature of perception require a more sophisticated and proactive strategic communications plan on the part of US and Western forces seeking to use reconstruction to mitigate the emergence of an insurgency. Afghan PRTs have no personnel exclusively devoted to this task, while the Iraq PRTs have the Public Diplomacy Officer who is responsible for spearheading this assignment. Host nation presence is particularly fundamental to the successful operation of this function, as public diplomacy must target the local population in order to support the PRT's larger mission.

### **Conclusion**

Although PRTs do not yet have any formal assessments to indicate how much they contribute to reconstruction and stabilization operations, most policy-makers seem to believe that they are having a positive effect. Regardless, the US government can and should identify ways in which the *ad hoc* nature of the PRT can be expanded, refined, and improved in order to make greater contributions to stabilization operations abroad. It is clear, however, that while Provincial Reconstruction Teams can assist in nation-building operations, they alone are not a stabilization strategy: they are merely a component of such a strategy. If military commanders abrogate their responsibility to seek unconventional approaches to defeat an insurgency because a PRT is "in the neighborhood doing the non-kinetic thing," then its contributions will be negligible, disconnected from larger objectives, and strategically irrelevant.

## Permanent Implants: Improving Embedded Training Team Support to Indigenous Military and Security Forces

Major Albert Tabarez—ARNG

### Preface

It is a common saying: a picture can say a thousand words. A photograph of indigenous soldiers, like that depicted in Figure 1, captures forever a moment in our nation's war effort – the use of native allies. In this case, these indigenous soldiers, who were trained and sponsored by our Army, are preparing to go out on a combined combat operation. What, then, are the words this picture can relate about these men, these fighters who stand beside us?



Courtesy of MAJ Albert Tabarez, US Army

Figure 1. Indigenous allies – mercenaries or patriots?

Among many things, what this photograph can tell or share is the momentary state of these soldiers and their equipment. The civilian pick-up truck for transportation, the uniforms with locally made unit patches, the clean but worn AK-47 assault rifle, the RPG launcher with safety-capped round, only a few of the many observations that can be made about these allied fighters. This picture provides some indicators and clues as to the quality of these soldiers.

What this photograph cannot tell or reveal is the state of these men's hearts and their true motivations. Are they fighting with us simply because we pay better today than our competitors—mercenaries? Or, are they fighting with us because they believe in a higher cause—patriots? Moreover, to what extent were they molded and shaped within from their US military advisors? Guns for hire or true believers, this photograph can never provide those answers.

This, however, leads to the question at the root of our advisor effort with indigenous military and security forces: what caliber of men do we endeavor to produce—mercenaries for today or patriots for tomorrow? The difference is significant; because what we desire to create will determine how we apply ourselves to building them.

## **Introduction**

History is filled with many examples of counterinsurgency efforts, US as well as other nations, with which to look back upon for lessons to employ in our current war. Regardless of the length of the struggle or the ultimate outcome, a common theme that emerges from these examples in history is the need for and use of indigenous forces to reestablish and maintain security of the population, to separate and isolate the insurgent who threatens it. The military adviser stands alone as a tool that has evolved in history able to enhance, increase and help bring about the desired capabilities of native military and security forces.

Within our own Army, the use of military advisors on a large scale is fairly recent, as is too the reliance upon conventional force soldiers to accomplish the mission. The last example of such a large scale US military advisory effort was during the Vietnam War through the Military Assistance Command Vietnam (MACV), over 30 years ago. In the intervening years between then and now, our military advisory efforts have been small scale and largely undertaken by unconventional soldiers. It is only since this war began that the need for and importance of the military advisor has again risen to a level seen over a generation ago.

In the last 5 years, the military advisor mission has shifted from an almost exclusively unconventional force role to a conventional force task. This shift has been the product of necessity: there simply are too few Special Forces (SF) units to do all that is required of them. Where once highly-selected and specialty-trained SF soldiers were the face of the US military advisor effort, now conventional soldiers of various skills and capabilities fill the tasking and often are selected only based upon timing (PCS assignment orders) or relevance (parent unit deems them "expendable" when forced to fulfill a personnel tasking).

For the military advisor or “team trainer,” it has been an evolving concept in how best to accomplish the assigned task from the Brigade Training Teams (BTTs) in 2002-2003, to the Embedded Training Teams (ETTs) in 2003-2005, to now the Military Transition Teams (MiTTs). The institutional mechanism used to prepare team trainers is only now coming into line, over 3 years after the first conventional force trainers went out into the battle space to work with indigenous forces. What is evident is that things are still in flux and that each passing day provides greater clarity and insight into how best to prepare, train and employ team trainers, now and in the years ahead. It is a task that will not diminish over time, but only increase.

To that end, what follows are only insights and ideas of what is needed down at the lowest level, at that point on the ground where an American Army officer and sergeant are working with an indigenous military or security force unit to increase their capability and effectiveness, often in a remote and austere location. This is where the lessons of loyalty, duty, respect, selfless service, honor, integrity, and personal courage – the 7 Army Values – will take root in another culture. This is where the greater battle lies. This is where the question will be answered as to what we as a force develop in our allies: mercenaries or patriots?

### **What Training Teams Do**

On the surface, it is simple: training teams organize, instruct, train, peer, coach and mentor an indigenous force unit to improve its capability, efficiency and effectiveness. Often this training falls into the main subject areas depicted in Figure 2, but to varying degrees based upon the knowledge and experience of the trainer, the unit to be trained, the priority of training, and the time available to train. These subject areas are highly codified, with extensive documentation and manuals available for the trainer to refer back upon, if and when needed. In essence, Figure 2 conveys what most would expect a team trainer or military advisor to focus on – well understood US Army concepts and lessons that are very objective and not subject to a lot of individual interpretation.

Once on the ground, however, it quickly becomes apparent that there is another completely different set of lessons that the team trainer must be prepared to instruct upon, Figure 3, because related issues will inevitably present themselves within the indigenous unit during his stay. How the trainer handles these issues, and the lessons he teaches as a response to them, will go a long way to establishing his credibility with the native soldiers and their ultimate receptiveness to his teachings. Unfortunately, the trainer is thrust into this position of becoming a developer of individual character with little to call upon beyond his own subjective biases

<ul style="list-style-type: none"> <li>➤ <b>Battlefield Tactics</b></li> <li>➤ <b>Administrative Management</b></li> <li>➤ <b>Logistics Management</b></li> <li>➤ <b>Maintenance Management</b></li> <li>➤ <b>Training Methods</b></li> </ul>	<ul style="list-style-type: none"> <li>➤ <b>Values</b></li> <li>➤ <b>Justice</b></li> <li>➤ <b>Cultural/Tribal Tolerance</b></li> <li>➤ <b>Religious Tolerance</b></li> <li>➤ <b>Good Governance</b></li> <li>➤ <b>Responsible Stewardship</b></li> </ul>
---	---

Figure 2. Objective Subject Areas.

Figure 3. Subjective Subject Areas.

and his own example; there are few established lesson plans or manuals to guide the conventional force trainer, and many will never appreciate or understand the full impact they have – either through proactive engagement or inactive neglect. It is in these subject areas that the team trainer has the opportunity to develop and instill the deeper qualities of patriotism, national identity, belief, faith, trust, hope, confidence and vision – qualities that separate the mercenary from the patriot – if he has within himself the capacity to teach them.

## **Improvements**

### *Alignment*

Foremost is establishing the force and structural alignment necessary to enable task completion, as depicted in Figure 4. Alignment is a leadership issue, and it falls upon higher command to ensure that the injected resources, established processes, expected output, desired outcomes, and articulated vision are well nested within each other and support the mission accomplishment. This alignment must be clearly conveyed and understood at all levels to avoid dispersed or wasted efforts. It is only when individuals fully understand their role in the process that a greater unity of effort can be achieved.

### *Quality Outcomes*

What training teams need to better succeed out in the battle space are clearly defined quality outcomes, those tangible measures and accomplishments that affect the middle tiers of alignment. It is at these three levels that the need is greatest for improved clarity about what is required and what is to be achieved. Figure 5 depicts ten such quality outcomes, of which five are defined, there are more to be sure, but these are the more readily apparent,



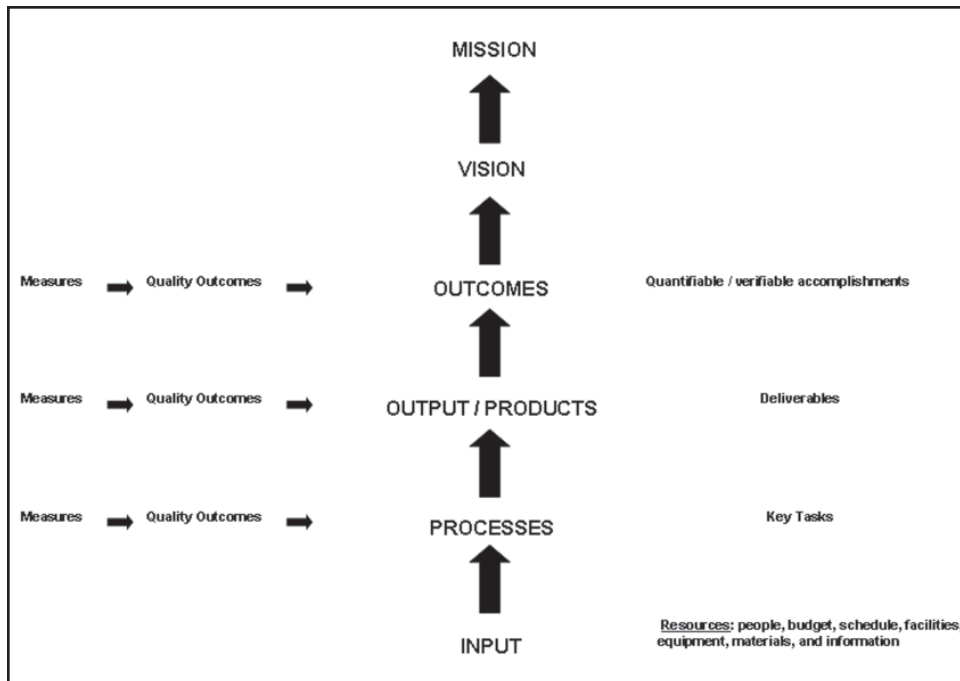

Figure 4. Alignment.

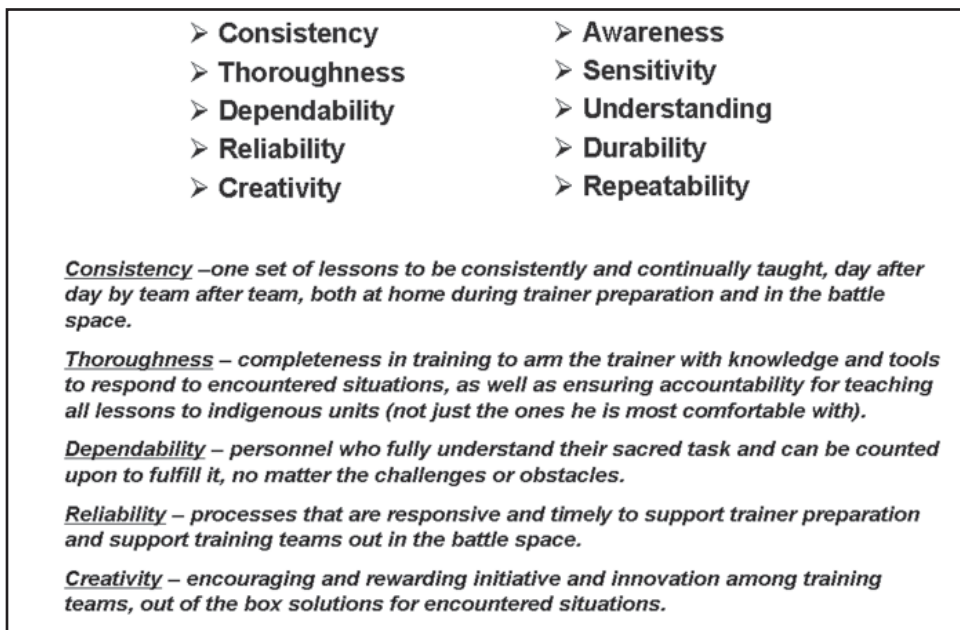

Figure 5. Desired Quality Outcomes.

The take away is that, when accomplished, quality outcomes help enable team trainers to build patriots from the inside, to water the seeds that trainers before them have planted. Further, some quality outcomes are First Level, with Second and Third Level effects. For example, accomplishing awareness of culture in trainers during preparation leads to greater understanding within the team, resulting in heightened sensitivity exhibited in the battle space during operations. The quality outcome of awareness manifests itself in understanding and sensitivity. This is true of all quality outcomes: they are interwoven and can impact upon others.

To help accomplish the desired quality outcomes, there are four specific areas that can be improved upon: longevity and length of tour; preparation and train-up; cross-functional organization; and doctrinal flexibility.

*Longevity and Length of Tour*

The quality outcome to be accomplished is consistency in the lessons taught to indigenous soldiers, with the desired effects being increased unit effectiveness and overall security progress. This consistency can only come about by keeping training teams on the ground longer to build upon the relationships that it takes months to establish. From the perspective of the indigenous unit, US military advisors and trainers come and go with high frequency. This can have a detrimental effect upon our ability to expeditiously accomplish the military advisor mission at hand, for it is always two steps forward and one step back.

To better manage and employ training teams and military advisors, serious consideration should be given to the establishment of a permanent military advisory unit, similar in style to MACV but on a world-wide scale, overseeing the training and employment of highly capable advisors. Assignment would be for a

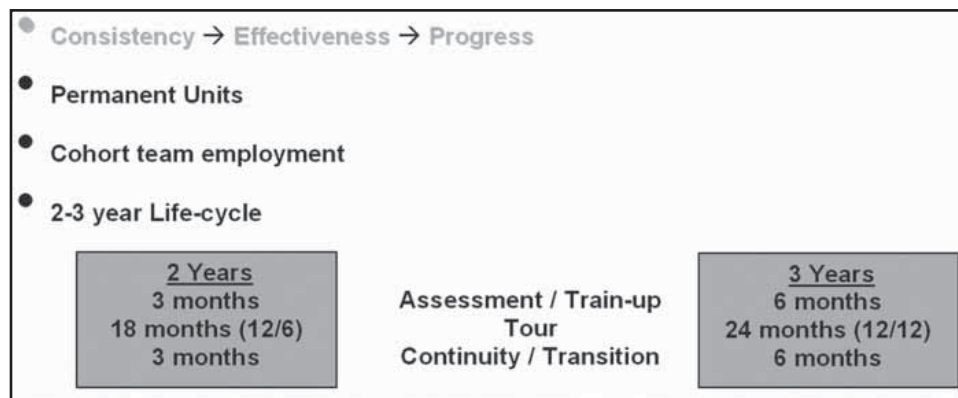

Figure 6. Longevity and Length of Tour.

period of three years, with selection mandatory to ensure only the best were chosen to serve as military trainers on the frontiers of freedom. To recruit and retain the best capable advisors requires a fundamental change in what is now accepted as the proper career track for personnel. People who have the skills and talent to train and work with indigenous forces should be rewarded and not punished for advisor duty. To create highly-capable indigenous units, you need motivated and inspired trainers to teach and advise them. Permanent military advisory units will go a long way to generating future crops of advisors that are better prepared and equipped than those that went out three years ago, and better than those who are going out there now.

Training teams should be employed utilizing the cohort concept. Where possible, they should train together, establish their bonds and deploy together. This approach does have a major drawback: when training teams are replaced on the ground it happens over a short period of time, usually 30 days, and working relationships are severely disrupted. It may take weeks or months before understanding and trust are back on a level comparable to what they were with the departed team. To help mitigate this, a possible solution might be to phase training team replacement over a 90-day cycle, with one-third of the team transitioning every 30-day period. Cohort is a valid concept that should be followed, but it should be modified to minimize the disruption to indigenous units.

As already mentioned, the assignment life-cycle should be for three years. This includes a six-month train-up period (nearly three times as long as currently planned for MiTTs) with a broader curriculum of subjects to be learned. What then follows is a 24 month period of duty as an advisor around the world. Ideally, one long combat-tour is envisioned (15-18 month) with several short duration tours to non-hostile areas (New Horizons, for example). At the 30-month mark, advisors would be earmarked for institutional support to train the next block of advisors or revise and update doctrine, policy, books and manuals.

Collectively, these approaches can help accomplish consistency. Understanding that longevity is the action behind the “commitment and dedication,” training teams must live, work and, if need be, fight with those they train, serving as examples of patriotism.

#### *Preparation and Train-up*

The quality outcome to be accomplished is thoroughness in the training given to military advisors and trainers, with the desired effects being usefulness and sustainability. Thoroughness in training is necessary to ensure that advisors are better

equipped with skills and knowledge across a variety of topics before they get into the battle space. Once on the ground, anything that the trainer encounters may have a detrimental outcome if he makes an inappropriate decision. Rather than hope the trainer has completeness of training, we must pursue it to the last detail—arming him with potential solutions for anticipated challenges.

As mentioned already, cohort employment of training teams should be the rule. However, during the train-up period, cohort training should be expanded to include a collection of teams that members rotate amongst. This should be done to expose team members to those most likely they are to work with on a higher level, for example, the four to five teams that will be on their immediate right or left in the battle space. Attrition of team trainers will occur due to casualties, medical emergencies, administrative loss, and other reasons, such that cross-leveling of trainers may be necessary. The disruption that can occur during such a time can be off-set by targeting cohort training to a collective of teams, not just one. In this instance, senior career professionals are being trained, so shuffling them around in training should help to instill mental agility and flexibility to the demands they will soon face.

To develop quality indigenous soldiers you have to invest in developing quality trainers and teams. Not every US soldier is an effective teacher and care should be taken to avoid putting into the battle space those who could harm our effort greatly due to lack of commitment, concern, or capability. Team leaders should be given a vote to reject those who demonstrate questionable character – the stakes are simply too high. The current method of personnel tasking does not always ensure that the best soldiers are sent out to become trainers. Quite often it is the unwanted that are let go from units that stand protectively over their “studs.”

Lastly, the reality on the ground is that there is a lot for a team trainer or military advisor to know, as shown in Figure 7. The focus of a career soldier’s career is often limited to tactical ability and fitness. Everything else until recently has been an afterthought for the conventional force trainer. The need to understand and thoroughly know the human terrain and the operating environment he is going into far outweigh the focus of his career. For many, it will come as a shock and on-the-job reactive training to learn this.

Together these methods can help accomplish thoroughness. In so doing, we can ensure that quality teams are sent forth, armed with the knowledge needed to be effective in the training of indigenous soldiers. It cannot be forgotten that though the trainer is working with the soldier, his impact extends to the wife and children of that native soldier, the second and third level patriot.

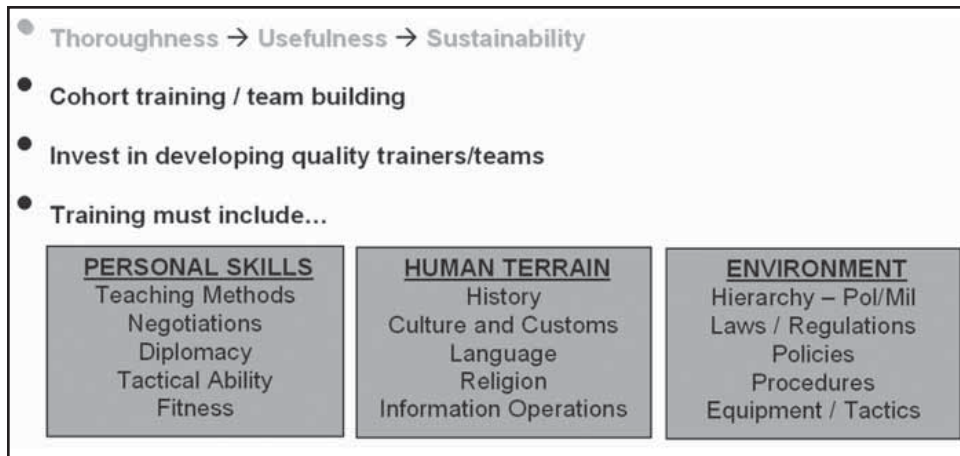

Figure 7. Preparation and Train-up.

*Cross-Functional Organization*

The quality outcome to be accomplished is sensibility in task organization and structure of the training teams, with the desired effects of relevance and efficiency. Each component of the structure must have purpose and be a sensible contributor to the training of effective indigenous military and security forces. If the task organization is incorrect, it will hinder the speed with which unit efficiency can be achieved.

One of the challenges with the organization of training teams is that not every MOS is represented in the structure, either at battalion or brigade trainer level. The impact is often that non-qualified trainers are tasked with training areas outside of

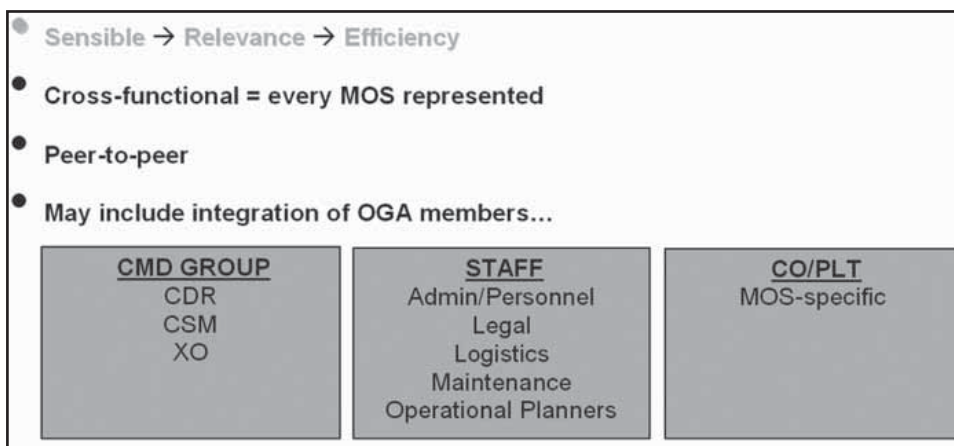

Figure 8. Cross-functional Organization.

their area of expertise. For example, take the case of infantry officers who were tasked to teach logistic and maintenance management to a newly formed native unit. The task will get accomplished to the best of their ability, but it will not be pretty nor will it be highly efficient, missing the mark for developing a self-sustaining unit. Such a prolonged effort could have been avoided had a qualified logistics and maintenance trainer been attached to the team from the onset.

Taking into consideration cultural factors, the selection of team trainers, particularly the officers, may need to be on par with the ranks of those that they are to directly interact with. This is not true for all countries, but it is true in those where our current efforts are focused. A trainer junior in rank may meet resistance to his efforts simply because the rank on his collar is less than that of the one he is trying to teach. This is not a large problem, but it does present itself enough to be a concern.

Training teams, when possible, should attempt to tap into the resources and support of other governmental agencies to better enhance the capabilities of their indigenous unit. Of course, this should be through codified agreements, but the need to collectively unite the efforts of multiple agencies towards a common goal is real. Indigenous units often have a real support need that extends beyond conventional military solutions—barracks, training ranges, family housing, etc. The resources are out there in the battle space, it only requires proactive and persistent dialogue to get them moving in the right direction.

It is possible to have cross-functional organization that is sensible and relevant. In so providing the qualified subject matter experts, more efficient and effective indigenous units can be built that truly have stand-alone capability—the empowerment of patriots.

### *Doctrinal Flexibility*

The quality outcome to be accomplished is depth of understanding in both western and eastern military doctrine, with the desired effects being creativity in developing solutions and responsiveness in implementing them. Understanding other ways of doing business allows the trainer to adapt to the goals and desires of the indigenous unit. Trainers and military advisors cannot be resistant to supporting the host government's security vision. This may well mean that the trainer is far more likely in the years ahead to deviate from the US Army force structure model and towards a hybrid that incorporates elements of other countries.

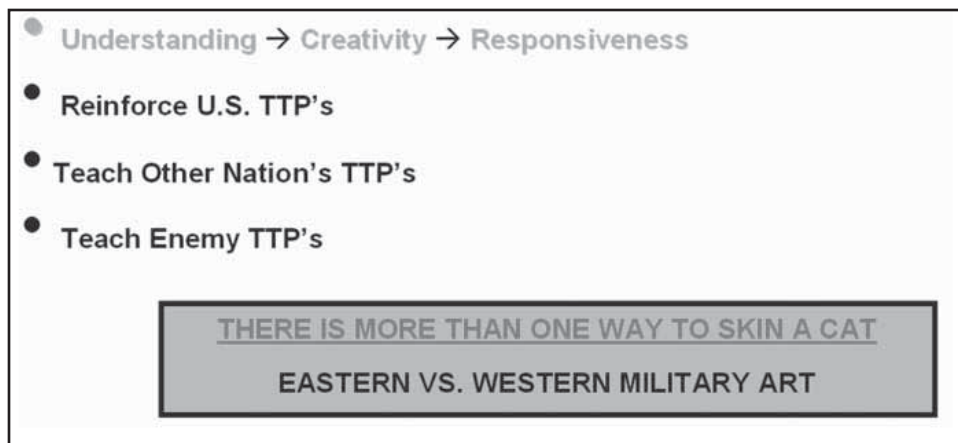

Figure 9. Doctrinal Flexibility

It is essential that team trainers thoroughly review and understand US tactics, techniques and procedures—this is the common ground start point. However, equally as important is to recognize the military culture that exists in the country and the historical shaping influences to better focus on those methods that may be observed, encountered and later taught, from whatever country they may have evolved from. In essence, training teams must be allowed to develop, teach and employ non-US solution sets to encountered challenges.

It is well within our ability to develop doctrinal understanding that extends well beyond the US vision. By providing awareness of other methods, trainers can be armed with useful information that enables more rapid solution development. In this regard, training teams must be prepared to teach other methods if the host-nation indigenous force does not want to do it our way. We cannot afford to stand in the way of patriots who have a vision of what they want their country to be or the form they want for their security forces. We must be ready to assist them in every way.

### **Summary**

To build better capable, more efficient and highly effective indigenous military and security force units, we need to recognize that we do have a clear choice in the quality of the product we create. We can train mercenaries or patriots, each with their own investment costs. For mercenaries, there is little need to change the way we are currently doing business, but with no guarantee of long-term sustainability once we leave. For patriots, we need an institutional and cultural shift in how we approach and develop military advising, but with the potential of creating true self-sustaining indigenous units that reach deeper down into their society.

On the higher level, this requires command to ensure that there is alignment at each level, and that quality outcomes (desired accomplishments) are clearly defined and understood within the hierarchy. At lower levels, there is the need to increase longevity on the ground to better ensure consistency; to invest in thorough education and training that better develops quality advisors and more capable teams; to organize along cross-functional lines that better adds responsiveness and efficiency; and to instill doctrinal flexibility that better enables creative solutions on the battlefield. Key to the oversight of all this is the need for permanent advisory units.

To paraphrase T.E. Lawrence from a 1933 quote, “We have no excuse, when advising, for not advising well.”

More direct and to the point, we have an obligation to future mothers and fathers that their sons will not one day be sent back to a land where we didn’t get it right the first time—where we missed our opportunity to instill and teach lasting lessons to another people, lessons that extend well beyond military knowledge and skills and take root in the hearts of patriots who will make and maintain the reconstruction and stability we seek. This is the impact of the military advisor and team trainer, his true role.



## **Day 1, Panel 3 Question and Answers**

(Transcript of Presentation)

**Moderated by  
Dr. Joseph Fischer—Command and General Staff College**

### **Dr. Joseph Fischer**

I'd like to thank the panel for four very insightful, well thought out papers. I'd like to take this opportunity to open it up to questions.

### **Audience Member**

My question goes to Captain Alexander. I understand your desire for the Civil Affairs (CA) outreach, and I'm interested in getting more people involved in CA, but I think part of the reason why CA is broken is because the United States Army Reserve (USAR) personnel acquisition system is broken. I'm a USAR officer. I have a Master's degree in International Relations. I've been looking for a CA position since 1992. The way you get into a CA position is to find a unit and ask them to let you in. They may have an open unit, but if you don't have the CA training, they don't let you in. The only way to get the CA training is to be in a unit in a CA position.

### **Captain Kris Alexander**

I could go on ad nauseum about the flaws in the Reserve personnel system. One of the things, for brevity's sake I didn't touch on as much as I wanted to in my paper is the fact that CA officers in the Reserves are what I call self-selecting. I am a proud member of the Reserve component, but I understand that there are flaws to the quality of product that's out there. There is a lot of good old boyism that exists in all Reserve component units. So yes, it is hard to get into those units. You don't really know who you get. I don't want to sound impolitic, but that's the tough thing. I am an Emergency Management guy. I think I would make a great fit in a CA unit. Like you, I sought and looked and could not join. They weren't interested. I guess they decided that ... so yes, there's probably some things that the Civil Affairs community could do to address. One of the things that the Military Intelligence (MI) community in the Reserves has done to fix finding the right people, because you're limited in that 50 mile circle, the MI community has gotten beyond the 50 mile circle with what they call the MIAD, which is the Military Intelligence Augmentation Detachment. They take those low density Military Occupational Specialties (MOS), I mean there's a handful of people in the Reserves who are, say, imagery analysts. Well, the company I just came out of command in before

I got back in the Active Guard Reserve (AGR) program, I had imagery analysts who literally lived all around the country that my Readiness Command paid their Temporary Duty (TDY) to fly, gave them a rental car, put them up in a hotel, to come drill with my unit because I couldn't find them within that 50 mile circle. So I think that's a way that Civil Affairs could ... that's a close target, that's a 50 meter target that they could engage and emulate the MI community in fixing that. But fixing the way that Army Reserve procures it's leadership is way beyond my pay grade, and I feel what you're saying.

#### **Audience Member**

This is really a comment about what Major Tabarez was saying about the teams. I think it's important to make the distinction that he was talking about Special Operations Forces teams. What I was talking about this morning were not. There is some significant differences that all apply to the things that he was saying. Special Forces (SF) teams are formed teams. They stay together for a long time. They could stay ...

[Audio abruptly cut off, continued on next CD.]

#### **Lieutenant General David H. Petraeus**

... within each of those areas is really pretty modest, as is, sometimes the expertise. It seemed to us that the ... the best example is good old Mosul University. Very early on we got this province council going, got the governor in there, sat down with the counsel members, said, "Okay, things are tracking reasonably well, what do you want next?" They said, "We'd like you to help us reopen Mosul University. We don't want to lose this entire academic year." We thought that was pretty commendable so I said, "That can't be too hard." I envisioned this little college over there. So I said, "Why don't I just drive over there right after this meeting, I'll check it out and get back to you." So I drove over, and it turns out Mosul University is a little bit bigger than Ohio State actually. Or Michigan State, I think it was – because it was over 30,000 students – had about 100 major structures, had faculty of over 4,000. They're a little bit inflated, as always, in that particular culture. Every one of the buildings had been looted before we got there except for one or two

So it was a pretty substantial undertaking. It's also about 110 degrees in May, and the temperature is headed north. So I stopped over at the Civil Affairs Battalion Commander's place on the way back to the headquarters and said, "Hey, what do you got?" He said, "Oh, we got this great Civil Affairs education team. Great young Captain. Was an elementary school teacher one time. Got a couple of sergeants. A couple of troops." I said, "Man, they can't even get out of the gate on the two vehicle rule." Oh, by the way, the chancellor of this University is a Western

educated, UK educated, PhD, about 68 years old. Comes all these cultural things we're talking about earlier. You know, you're going to marry up a 26 year old Captain with a 68 year old PhD and show respect. And, by the way, had no resources really, to be truthful. So we sort of went back to the Command Post, sat around, scratched our heads, and we had one of the Aviation Brigades, we had sort of parceled out a lot of its units, wasn't doing active operations at that point in time. So we called up that brigade commander and said, "You won the lottery, you're in charge of rebuilding Mosul University." By the way, this guy has a large staff, he's got lawyers, contractors, Class A agents that can carry money. All the different staff functions represented. Signal officers, and he's got a huge number of people with American ingenuity who turned out ... one's a former Microsoft engineer and could rewire the place. Another guy is an amateur plumber. You know, then they partnered with Iraqis. He partnered with the chancellor, flew him back and forth to Baghdad, which is a common practice there. By the way, incorporated the several Civil Affairs education team members and got that thing going, actually turned out to be a pretty good model for everything. So if you're going to redo the telecommunications, you know, Ministry of Telecommunications turned to the Signal Battalion Commander, tell him to partner with the Captain and the Major from CA who are the signal guys, help out that ministry.

That causes me to think, then, that maybe we should actually be trying to build functional organizations that can plug into units and help them, and in fact are experienced, for example, with these kind of folks you're talking about. The police trainers, for example, we've got an entire company of Military Police trainers out of the Reserves; didn't know we had that organization until it showed up. It's terrific. And they are all professional policemen, and they're all mature. They're sort of more closer to middle age than young and, in fact, they could establish a police academy like that and get things going, and knew what to do and could take mission orders. Same with the corrections unit trainers. Again, another organization I didn't know we had. Same with the engineer group headquarters. They're professional civil engineers. It seemed to me that that's a pretty good way to go if you can get the functional kinds of organizations. Now how that applies when it comes to health affairs or some of these others ... of course, the ones I've talked about are all pretty linked to security issues and are naturals for the military.

The question is, what do you do when it comes to agriculture, finance, and all these other areas where we don't have ready made teams, necessarily, or units, necessarily, to draw on. But that could be where we go. I'm really sort of exploring this out loud because it sort of ... you really did get us thinking here, I think. In part because this crowd sourcing idea, to some degree, was tried for Coalition Provisional Authority (CPA). And God bless Ambassador Bremer, who stayed for 15 months or so, but the rest of CPA was a little bit of a very highly talented pool of people who would enter a revolving door, at times, and every time you went

down to Baghdad and visited the advisor to the Minister of such and such, it's a different guy, and we invested quite a bit in these people to try to get them spooled up on what the needs of our respective areas were, only to find out they're gone three months later or four or five, maybe even six months later. Again, that would be my fear, if you don't have them into a unit that, again, deploys on its own and it's really an established organization.

So again, I wonder sometimes if we don't need to think the whole thing through and figure out whether Civil Affairs are the answer. I hope people aren't blogging all this out because this truly is just sort of searching and questioning and examining. But again, as I mentioned, our experience ... not to say the Civil Affairs guys weren't heroes, because they were. They did fantastic stuff. But they generally required, in a sense, embedding with other large organizations that could deliver pretty massive quantities of stuff because these efforts are industrial strength rebuilding. They're not small ... we're talking about rebuilding entire countries, not just putting in a couple of wells and water purification units or something like that. So does that spark anything with you?

#### **Captain Kris Alexander**

Yes, sir. I concur about the heroism of the Civil Affairs guys. I think they do a good job in their limited capability. From my background as an Emergency Management planner and doing those type of operations, when I talked about the shelter operation, you know, that 40,000 people that we sheltered in a 72 hour period. That didn't just happen accidentally. It was a ... literally a community effort. Across the entire spectrum. So yeah, in the military we do great things like the security angles of it, but one of the things that came out in the sheltering operation was we ended up sheltering livestock. So there was an agriculture angle to it that we had to go into unusual avenues, things you don't think of traditionally. So ... agriculture being a highlight that we don't do very well in the military. We don't have anybody who does that and it's important in a developing world. So the Civil Affairs people I talked to, sir, weren't real interested in this idea. I think it was kicking over their apple cart. But the capacity ... we have the people. I think we have to build the capacity. There's some certain things that we do very well, like you mentioned the Corps of Engineers are very good at doing the infrastructure piece ...

#### **Lieutenant General David H. Petraeus**

I didn't say the Corps of Engineers. I said Engineer Group Headquarters. I'm not saying the Corps is not good at a lot of stuff, but there's a big difference between these Engineer Group Headquarters that work for a conventional units and the Corps of Engineers, which is out there doing other stuff.

**Captain Kris Alexander**

Yes, sir. And those type of people know a lot about the things. Running a public utility is an entirely different thing. So the engineers might not necessarily have the expertise. I think we're in agreement that we need to expand our capability. Just how do we do it? And that's the big thing. I think you can get the people you want. They're out there. They want to help. It's just how do we integrate them into the force in a meaningful way, where not only do we train and integrate them, that we can retain them to use them later on for the next mission. I think that's the problem we have to solve, sir.

**Audience Member**

Yes, Dr. Stewart for Captain Bran. Interesting about Provincial Reconstruction Teams (PRT). It appears that the PRTs to the Europeans are sort of a way for them to participate in operations without actually having to shoot somebody. So that confirms what I've sort of believed all along. And as the PRTs ...

**Lieutenant General David H. Petraeus**

And they only do it in safe areas. No, seriously. That's why no PRTs in Iraq, that's why PRTs in northern Afghanistan.

**Audience Member**

And as the PRT mission expands, when they take over more and more, then there's going to be a challenge as to how much they're going to actually engage in their own security. Ambassador Jalali came to the National War College last year and talked about a particular team, I won't mention the country, but it was probably the Dutch, who, when they saw an Improvised Explosive Device (IED) outside their front gate, refused to leave their post. Locked themselves down, and called for the nearest US team to come help them, because they weren't going to go out there and mess with that. That was for the United States to do. We're the only ones that can take danger. So as the PRTs expand, I'm not sure that they're going to even provide the limited model that we think we might have for Iraq.

**Lieutenant General David H. Petraeus**

The Dutch, the Canadians, the Brits have been pretty robust, actually.

**Audience Member**

Perhaps it was the Danes, sir.

**Lieutenant General David H. Petraeus**

It might have been. I mean, they are engaged big time in the fight. They're fighting, taking casualties and all that. It's the ones you look in the northern rim provinces ... getting PRTs for safe places is not hard. It's the same as sort of doing normal diplomatic and rebuilding. The challenge is how to do it in the very dangerous places. That's where it comes down in Iraq. If you have a brigade headquarters per province, do you need an additional organization called the PRT, or could you embed the two of them together because, of course, it's the brigade commander that's the guy meeting with the governor, meeting with the police chief, meeting with the other members. Perhaps you can partner it all together. In fact, that might be, as you go over there to Iraq Reconstruction Management Office (IRMO) and develop this. You should also, when you go over there, it will be very instructive to compare the number of people who are now advising the Ministries of Interior and Defense with the numbers who are advising all of the other ministries in Iraq put together. Again, I think that will be very, very illustrative for you.

**Dr. Joseph Fischer**

We probably have time for about two more questions. Anyone?

**Audience Member**

Actually, I'd like to throw two questions out, and they have to do with the same thing, but it dovetails what you were just talking about looking at Civil Affairs ...

**Mr. Roberto Bran**

I should point out that he was a Battalion Commander in Muqdadiyah, which is a very troubled city in the Diyala province, which is a very troubled province of Iraq. On his watch, they actually got the thing under control through partnering with Iraqis and did a tremendous job. Very, very impressive actually.

**Audience Member**

With copious amounts of money. And I preface everything with that.

**Mr. Roberto Bran**

Well, money's ammunition.

**Audience Member**

Lieutenant Colonel Newell. I'll talk about Muqdadiyah for just a second. It's an area of about 16,000 square kilometers, 240,000 people, mostly agrarian. A large agrarian society, spread out. But it is a place where Sunni, Shiite, Kurds, and Arabs

all met in one place. A lot of irrigation. A lot of irrigation problems. I'll talk about the issues that we had. I had a visitor once who asked me what the number one problem was in my area, and I said, "Clean water." He then proceeded to ask all the politicians what the problem was, and they all said, "Clean water." How do we provide clean water to 240,000 people spread out over that large an area?

My question to everybody else who came by is why is this a military problem? Unfortunately, I have to ask you, are the problems we're talking about necessarily a military problem, or should I not, as a task force commander who is risking my life and my soldier's lives in Iraq, not expect the other government agencies in the United States of America to pony up and bring things to the table that will do things? I needed a guy who could talk to me about clean water. We educated ourselves, and thanks to General Petraeus and a \$360,000 donation, we put a large dent in a couple of areas, but it wasn't a Civil Affairs team, it was the Iraqis themselves who answered the problem. So the flip side is I have the other government agencies out there that are probably under represented in their ability to provide the things that we're looking for. And as typical military guys, we stand up and say, "You know what, if nobody else will figure this out, we can." I don't know that that's headed down the same route.

I'd ask your thoughts on that as I'm following up with ... in the cases where we said the PRTs ought to be a State Department run agency that has solely tasked the 80 to 120 people to do that, why are we not looking at the indigenous country themselves to provide them, rather than ask the State Department to bring experts from the United States to do something, particularly in Iraq, where there are engineers, there are sanitation experts, there are ... if you want it, you can find it in Iraq. But it's a matter of bringing them together in some kind of organization. Create a PRT team out of Iraqis and go solve some of these problems. I did it on a small scale, and I always thought in my area, for the year I was there, and I know that's not always the case ... bigger problems. My other problem was hydroelectric power. A \$99 million problem that I wasn't going to solve in my time. They don't normally get solved in the next 30 years. But I would ask all of you, first, why is the responsibility a military response in fixing it, and second, why is it not let's help them grow themselves by starting with the PRTs that really have the power to affect change in the country?

**Mr. Roberto Bran**

Sir, to answer your first one, or to partially answer it as best as I can ... I can't speak for the other agencies or the federal government. I can say that Senator Warner, I think it was about four or five months ago in a Senate Hearing sort of blasted the rest of the federal government and brought up the whole point that Department of Defense (DOD) is the only ones who are sending everyone they've got. Everybody

else is sort of sending garbage over there. I don't know if that was a fair assessment of who's being sent over there, but it definitely expresses the frustration of the fact that, it's unfortunate, but the US military is really the only institution that can be compelled to go over and do these things, even though everybody else knows it's important. The fact that a company grade officer like myself would be sent over on a State Department assignment that's coded for a GS-15 speaks volumes about how desperate they are to get people who are willing to volunteer and have the ability to contribute. You would think that organizations would have people raising their hands to do that, but they don't.

Then on the second one, actually there are a lot of foreign nationals working within the PRTs in both the Afghan and the Iraqi model, sir. There's a whole bunch of them. The key reason you've got to have US government personnel there is it's US government money that's being spent, and just the strings and the controls on it, they don't want to just hand the money over to the Iraqis or the Afghans, but in 2004, we did do a concept study to start fielding Afghan PRTs. PRTs that would be solely composed by Afghans. And we were going to just turn over responsibility for these things from the Coalition to the Afghans. It was actually ... we got pushed back from the Embassy on it. The military were about the only ones that were in favor of it, and it died. It died within ... I don't think it made it more than two weeks.

#### **Lieutenant General David H. Petraeus**

I think a number of different military units tried various schemes like that. We were actually en route to building an Iraqi Corps of Engineers up in the north, and it actually was very much lifting off. The challenge was always one of disposable money. It was a problem of funds. I mentioned the huge success of those early on. The 101st alone, for example, had \$53.5 million, something like that, contrary to the perception we had all kinds of money, we did spend it very rapidly in the beginning. But then it was very much metered from then on to ... in fact, to be fair to the others. The fact was, that pool could have been a lot bigger and we could have made great use of it because we generally ... we had no overhead whatsoever. All the money we got went immediately into ... typically into the hands of Iraqi workers, Iraqi construction firms and so forth because, of course, we had our own security, we had our own contracting, we had our own everything, as opposed to contracting a big firm which subcontracted, which did this and on and on and had to have a lot of security, which increased as time went on.

So I think, again, you have to look very, very hard at how much can we provide in that venue as opposed to very programmed amounts of money? For what it's worth, when I went back as the Multi-National Security Transition Command-Iraq (MNSTC-I) commander, I had three conditions before I went back, or at least I



tried to ... I said, "There's three things I'd sure like to have before you ... you're doing this to me, by God. I'd hope that you could help us out." They were ... first of all, I needed six contracting officers to go back over with me because MNSTC-I had no contractors out in any of the six major subordinate commands. It's tough to do business if you don't have them, obviously. Six Class A agents to go with them so they could carry the money and not have one person doing both, which is illegal. There were a couple of individuals by name that I took, but then we actually did a reprogramming action to create disposal funds for MNSTC-I. It was modest at that point in time, \$40 million, but then in a subsequent supplemental, we actually got \$180 million. It's amazing. It was that \$180 million, by the way, that helped carve out \$300,000 for Pete Newell and his guys up there.

Again, you could do extraordinary stuff with that money. There were billions of additional dollars – \$5.3 [billion] I think in that supplemental alone to give you a sense of the magnitude. But that was going for very, very big ticket items, and very appropriate, I think, for Congress to say where some of that should go in terms of the items of equipment and what capabilities it would provide for the Iraqi security forces in the Defense and Interior Ministries. But a lot of it comes down to doing things that we're not used to doing, which is giving commanders money and saying, "Make assessments and go out and spend it. We trust you." We trusted you, as I said, to pop off 113 missiles on the way to Baghdad. I mean, that's more money, I think, than we had for all of the year. \$53 million is not a lot of money. By the way, we did over five thousand projects with \$53.5 million. If you can get it going early, because of course, the longer you're there, the more challenging things become. One other challenge in Iraq, I think, that's worth pointing out is that actually only now, of course, do they have a government.

So when you were trying to do things that you wanted to hand off to the Iraqi government, we were almost in a perpetual state of transition. There was the Iraqi governing counsel with a CPA, then the Alawi government, then the Jafari government, and now the Malaki government. That's four governments within the period of about two years, and it's just about impossible to develop any kind of capability, much less real capacity, in some of the ministries. In fact, in the Ministry of Interior, they didn't even spend about ... I think it was \$80 to 100 million because they didn't have the capacity internally to do a reprogramming action with their Ministry of Finance. Even though we knew it, they knew it, everybody was trying to work it, and bureaucratically it was just too darn hard for them. Now that there's that government, if those ministries can be enabled, can be assisted, and can develop capacity and not get torn apart by the sectarian violence, you could build that kind of capacity as well as capability and actually hand off an Iraqi Corps of Engineers in an area to, for example, the Ministry of Planning, which carries out that kind of activity. But again, the complexities of that, he's real familiar with.

But for what it's worth, that's worth sharing as well. It is interesting, though, that these PRTs are largely military individuals because I do think that the intention in the beginning was that these were going to be, again, sort of additional assets for provinces that would provide unique skill sets that actually aren't available in uniform. Again, how to get the rest of the government engaged in this, and something that is admittedly extraordinarily dangerous, very difficult in an environmental sense, 120 degrees in body armor and Kevlar, and all the rest of that, is a real serious challenge, and it's not one to be scoffed at. But it is one our government's going to have to come to grips with, because if we can't do that, then again, if you can't enable other ministries, you might get the ministries, certainly of Defense and probably of Interior sorted out, but the others will let it down over time, and the national super structure that's over the top of that will not be able to sustain it. So there is absolutely nothing easy about this.

In State's defense, we always felt as if they had not been resourced adequately, overall, much less for Iraq and Afghanistan. They just do not have the capacity themselves. If you do the Math, I think State has less ... in fact, I think we had the budget for MNSTC-I exceeded ... over the course of two and a half years, exceeded State's annual budget. But don't quote me on that or blog it, please, but it's somewhere in that neighborhood, depending on how you do the numbers. The number of foreign service officers in State, I believe, is under 10,000 and it may be under 9,000. That is not a huge organization when you know of all the things that organization is trying to do, when you look at what we have been able to muster in some previous endeavors that our country has taken on. Thanks.

**Dr. Joseph Fischer**

Well, it appears that Ken is applying the shepherd's hook to me right now, so what I would like to do is ask for a round of applause for our panel and for the lively discussion that followed it. Thank you.

## **Security Assistance in the Vietnam War**

### **Dr. Lewis Sorley—US Army Historical Foundation**

I would like to believe that we are making some progress in our understanding of the Vietnam War. Only a few years ago, most people seemed to think that our involvement there was pretty much of a uniform whole. Now there is fairly general recognition that the early years and the later ones differed in many important respects.

The task assigned me today is to discuss security assistance in the Vietnam War, a topic I will construe broadly to include not just advisors, materiel, and financial resources, but the entire compass of American influence. The emphasis will be on the later years of our involvement, a period when American forces were being progressively withdrawn but the war was, as I have discussed elsewhere, progressively being won.

This approach will permit me to address key aspects of the American and South Vietnamese leadership; their understanding of the nature of the war and how it should be prosecuted; and the whole complex of programs aggregated under the rubric of Vietnamization.

In the interests of time, and for the sake of simplicity, I will talk to a number of these programs in separate chunks, five in all, and one sidebar. I plan to reserve a considerable amount of the allotted time for questions and discussion.

#### **Chunk 1: Character of the Leadership**

In the latter years in Vietnam, American forces were led by three men of like character, shared values, high intelligence, and personal modesty—General Creighton Abrams as COMUSMACV, Ambassador Ellsworth Bunker as head of the embassy, and Ambassador William Colby in charge of CORDS. These qualities enabled them to focus on the tasks at hand cooperatively and productively.

#### **Chunk 2: Continuity of the Leadership**

General Abrams served for five years in Vietnam, the last four as commander of all US forces there. Ambassador Bunker held his post for six years. And William Colby, in charge of American support for the pacification program, served for more than three years. On the South Vietnamese side, President Thieu held office

from the elections of 1967 through the end of the war, less a few days, a period of nearly eight years. General Cao Van Vien, Chief of the Vietnamese Joint General Staff, held that post continuously from the autumn of 1965 through the end of the war, a period of some nine and a half years.

In the earlier years of American involvement in Vietnam, General Westmoreland served as commander for four and a half years. In contrast, during that period of time he dealt with four ambassadors (three if you count Cabot Lodge, who had two stints—separated by Maxwell Taylor’s single year—as one rather than two) and had no single associate in charge of American support for pacification (the Colby role) until the last year of his tenure. And of course during his service there the Vietnamese side presented a seemingly endless series of coups and counter-coups.

I should acknowledge that in Vietnam leadership continuity did not extend much below the upper echelons. A one-year tour policy was in effect for much of the war, ensuring that most Americans rotated in and out on a fixed schedule. Only among general officers, and in the case of voluntary tour extensions by some others, was there a longer tenure. Even then, people often changed jobs during their tours, adding further to the characteristic turbulence. This was, I feel sure, the source of considerable frustration for the South Vietnamese. Journalist Kevin Buckley once reported meeting a Vietnamese who had had 47 different American advisors. I feel considerable sympathy for that poor fellow, whoever he was.

### **Chunk 3: Nature of the War**

The senior leaders of the later years shared a common understanding of the nature of the war, and hence, of how it should be prosecuted. All spoke often of “One War,” by which they meant the component parts of combat operations, pacification, and improvement of South Vietnamese armed forces. A corollary was that the combat operations underwent radical revision.

A blueprint for understanding the war and conducting it effectively had been provided by a study—known as PROVN, short for Pacification and Long-Term Development of Vietnam—conducted when General Harold K. Johnson was Army Chief of Staff with General Abrams as his Vice Chief. I view this as a very important document and one whose findings are of central relevance to the concerns of this conference. PROVN held that the underlying objective was “the restoration of stability with the minimum of destruction, so that society and lawful government may proceed in an atmosphere of justice and order.”

Thus PROVN insisted that “at no time should...combat operations shift the American focus of support from the true point of decision in Vietnam—the vil-lages.” The war as it was being conducted by General Westmoreland was not suc-ceeding and could not succeed, PROVN found, because it was aimed at the wrong objective. “PROVN contends,” read the study’s foreword, “that people—Vietnam-ese and American, individually and collectively—constitute both the strategic de-terminants of today’s conflict and ‘the object...which lies beyond’ this war.”

Not surprisingly, General Westmoreland rejected PROVN out of hand, but when Abrams took command he quickly implemented its approach, even bringing out one of the principal authors to serve as his long-range planner.

Search and destroy operations were replaced by clear and hold. Recalled Gen-eral Fred Weyand, “The tactics changed within fifteen minutes of Abrams’ taking command.” Early in 1969 an Army liaison team visited Vietnam. Observed one of its members, an experienced infantry officer who had served two previous tours in Vietnam as a battalion commander and an advisor: “It’s a new and different war.” The key changes he cited were that “US Army units are fragmenting, with small unit operations replacing searches by battalions and brigades; and second, we are now working with the Vietnamese to an unprecedented degree, targeting on the enemy among the population rather than forces hiding in the jungle.”

In such a war the measure of merit became not body count but population secured. Abrams told his senior commanders that “the body count does not have much to do with the outcome of this war. Some of the things I do think important are that we preempt or defeat the enemy’s major military operations, and eliminate or render ineffective the major portion of his guerrillas and his infrastructure—the political, administrative and paramilitary structure on which his whole movement depends.”

And, he said, “it is far more significant that we neutralize one thousand of these guerrillas and infrastructure than kill 10,000 North Vietnamese soldiers.” Speaking to regional ambassadors, Abrams went even further. “I don’t think it makes any difference how many losses he [the enemy] takes,” he asserted. “I don’t think that makes any difference.”

Said Abrams of the enemy: “His strength is not in these divisions. His strength is inside this [VCI] program. It’s the part he can’t let go down the drain.”

The tactics changed accordingly. Found a study prepared several months into the tenure of the new commander, “General Abrams has begun to concentrate

much more on area control than on kills. He has been aided in this approach by his defense in depth, particularly around the major cities.”

Soon the new tactics were widely in evidence. General Harris Hollis, commanding the 25th Infantry Division, came to think of his command as a “reconnaissance division.” General John Wright had earlier spent a year in the 1st Cavalry Division, going home in September 1966, then returned to Vietnam in May 1969 to command the 101st Airborne Division. “I think the most significant difference,” he said in contrasting the two periods of service, “and it was just a spectacular difference, was the involvement of the division in civic action and rural development programs in our area of operations.” Even General Julian Ewell, widely regarded as a devoted seeker of body count, was moved to say “I’m perfectly willing to admit pacification’s my primary mission.”

A key element of the tactical approach under Abrams was sensitivity to collateral damage, the euphemism of the day for civilian casualties and destruction of property. “My problem is colored blue,” Abrams told his staff. By that he meant his problem was with the actions of friendly forces, traditionally depicted in blue on battle maps (as contrasted with red for the enemy).

At one point General Abrams commissioned a study that came to be known as “Where Shall We Let Peace Come to Vietnam?” Captain Barry Horton, a brilliant young Air Force officer, was named to head the study, initially to determine what areas should be ruled off limits altogether for use of tactical air strikes, then expanded to consider use of artillery as well. Soon Captain Horton came back to report that he was running out of episodes to study. The field commanders, listening to Abrams’s concerns, had gotten the word and were on their own reining in excess use of firepower in populated areas.

#### **Sidebar: 1967 Considered**

I have described the earlier years as those when General Westmoreland was in command (thus 1964-1968) and the later years as those of General Abrams’s tenure (1968-1972), and have characterized the differences in rather stark terms. There are some who suggest the split between the two periods should be identified as occurring a year earlier, in 1967 rather than 1968, and that General Westmoreland and his deputy for pacification support, Robert Komer, should be credited with launching the new and more effective approach to pacification.

The evidence, and it is voluminous, suggests different conclusions. Under Westmoreland US forces focused almost entirely on large-unit combat actions,

primarily in the deep jungles. Fixated on these operations, Westmoreland largely ignored upgrading of South Vietnam's military forces, and likewise left entirely to them support for pacification and rooting out the Viet Cong infrastructure in South Vietnam's hamlets and villages.

Wrote Lieutenant General Phillip B. Davidson, Westmoreland's J-2 during this period, "Westmoreland's interest always lay in the big-unit war. Pacification bored him." Search and destroy operations, observed Davidson, "accomplished little in providing the secure environment which pacification required."

Ambassador Ellsworth Bunker later suggested that when the United States first became involved the political and psychological nature of the war were not understood. And "because we didn't understand it our military thought we could get in and do the job and get out much more quickly than proved to be the case. Therefore I think that's one reason we were slow in training the Vietnamese, instead of starting really to train them in an intensive way when we first went in there."

Equally important was the failure to equip the South Vietnamese with weapons equivalent to the first-line materiel provided the enemy by their communist patrons. Only when General Abrams arrived on the scene, beginning with his year as Deputy COMUSMACV, did the South Vietnamese begin receiving weaponry comparable to what the enemy had had for several years.

As Deputy COMUSMACV Abrams cabled Army Chief of Staff General Harold K. Johnson. "It is quite clear to me," he said, "that the US Army military here and at home have thought largely in terms of US operations and support of US forces. Political pressures and prestige items have forced us spasmodically to give attention to Free World Forces. ARVN and RF/PF are left to the advisors. I fully appreciate that I have been as guilty as anyone. The result has been that shortages of essential equipment or supplies in an already austere authorization has [sic] not been handled with the urgency and vigor that characterizes what we do for US needs. Yet the responsibility we bear to ARVN is clear. I would look forward to the day when the Army Weekly Buildup Progress Report would report our Army progress in fulfilling the Army responsibility to ARVN and RF/PF. The groundwork must begin here. I am working on it."

In the autumn of 1968, Abrams, by then in command of US forces in Vietnam, cabled General Wheeler and Admiral McCain. "The ARVN get relatively less support, both quantitatively and qualitatively," he pointed out, "than US forces, i.e. artillery, tactical air support, gunships and helilift." Meanwhile ARVN forces were suffering more KIA, both actual and on the basis of the ratio of enemy to friendly

killed in action. "I am led to the conclusion," stated Abrams, "that the cited results indicate progress in ARVN leadership and aggressiveness. In addition, the lower ratio of enemy to friendly KIA, which I attribute in part to thinner combat support, is a further argument for expediting the upgrading of ARVN equipment."

Meanwhile Westmoreland was, through the conclusion of his tenure in command, successful in his own terms, killing a huge number of the enemy. He had pinned his hopes on thereby dissuading the North Vietnamese from further aggression against South Vietnam, but that outcome did not result. Instead they poured in more and more troops, denying Westmoreland his long-sought goal of reaching the "crossover point" at which he was killing more of the enemy than they could replace.

Westmoreland, in his memoirs and in a flood of correspondence and public addresses over several decades, maintained that 1967 was a year of allied triumph which had forced the enemy to change tactics and conduct the following year's Tet Offensive in hopes of changing his battlefield fortunes.

Others, many others, saw things differently. By May of 1967 President Lyndon Johnson was referring to the war as "a bloody impasse." That same spring General William Rosson moved from MACV to a field command. "I saw US strategy as being largely reactive and fluid," he later wrote. "In retrospect, pacification should have been at the heart of the higher and field strategies."

In early December 1967 a group of prominent Americans, including General Matthew Ridgway, met under the auspices of the Carnegie Endowment for International Peace. "The emphasis should not be on the military destruction of Communist forces in the South but on the protection of the people of South Vietnam and the stabilization of the situation at a politically tolerable level," their report held. "Tactically, this would involve a shift in emphasis from 'search-and-destroy' to 'clear-and-hold' operations."

Later that same month Robert McNamara told a Tuesday Lunch at the White House that "the war cannot be won by killing North Vietnamese. It can only be won by protecting the South Vietnamese."

Even General William E. DePuy, architect of the search and destroy approach to the war, subsequently admitted it was "a losing concept of operation."

These judgments were rendered in the same season in which, back in the United States to address the National Press Club, Westmoreland in a contrary assessment



told reporters “I have never been more encouraged in my four years in Vietnam” and that we had reached the point “when the end begins to come into view.”

As for Robert Komer, he was at best a transitional figure, with any real progress in pacification awaiting the arrival of William Colby as deputy and then successor to Komer.

We can credit Komer with engineering the consolidation of responsibility for pacification support under MACV, establishing the mechanism which enabled his successor to achieve a large measure of success.

But it was Colby who devised (along with Clay McManaway and Robert Montague) the Accelerated Pacification Plan that, in the wake of the enemy’s Tet Offensive of 1968, greatly expanded government presence in rural Vietnam; Colby who revived the moribund Phoenix program that rooted out the enemy infrastructure in Vietnam’s hamlets and villages; Colby who identified improvement in the Regional Forces and Popular Forces as key to gains in pacification; and Colby who was able to work with the South Vietnamese in a harmonious way and persuade them to adopt such programs as their own.

Daniel Ellsberg recalled that Komer “loved his nickname, Blowtorch” (an appellation almost certainly self-invented, despite what has been reported elsewhere as to its origins). As usual, Komer had it about half right. “Blowhard” would have been right on the mark. The character and personality traits the nickname represented were not, in any event, suited to achieving progress in pacification.

General Walter T. Kerwin, Jr., who was MACV Chief of Staff during most of the time Komer served in Vietnam, succinctly described the problem. Komer, he recalled, was “one of the most egotistical, self-centered individuals that you’ll ever run across. Brilliant man, tremendous ideas. His only problem is two-fold: he can’t implement his ideas; he can’t sift the ones that are not good from the ones that are good. He just antagonizes the hell out of everybody, openly, to the point that he denigrates the tremendous intellect that he has.”

Heavy-handed, self-absorbed and insensitive, Komer was also destined for trouble with the South Vietnamese. Although he later prided himself on having bulldozed them into doing things his way, the cost—even if his assessment is correct, which is doubtful—was high. “The pacification in South Vietnam by Komer’s team during 1967-1968 was a clear quicksand,” wrote Major General Hoang Lac, who had worked in the program on the Vietnamese side. “Ambassador Komer

can't even pacify himself. How can he lead the 'hearts and minds' program, pacifying the mass?"

ARVN Brigadier General Tran Dinh Tho, author of a postwar monograph on pacification, was equally candid, citing Komer's "obsessive preoccupation with appearances which led to the tendency of substituting statistical results for true achievements."

Soon after Abrams took command Komer was on his way home, replaced by Colby as MACV Deputy for CORDS. The precipitating event may well have been a briefing at which Komer displayed a status of pacification map. Abrams studied what that portrayed for a moment, then brought Komer to a halt. "Do you mean to say that, after all these years, and all this expenditure, we still have within firing range of this base a VC hamlet?" he asked menacingly. On the way out of the briefing, one officer asked another in low tones, "Do you think Komer knows he just got fired?"

Robert Komer was not an important figure in the Vietnam War, except possibly in his own mind. Instead his blustering and lack of candor may be said to have delayed progress significantly. When he returned from Vietnam, Komer later conceded, "I left with my tail between my legs," an uncharacteristic admission perhaps explained by the fact that he was under oath at the time.

It was only when the incomparable team of Bunker, Abrams, and Colby began to work together that things went better, much better. That was in 1968, not 1967.

#### **Chunk 4: Intelligence**

Intelligence was an aspect of all-encompassing importance in the war in Vietnam. George Jacobson, a long-time participant in the pacification program (I think he served, in and out of uniform, the incredible total of eighteen years in Vietnam), often observed that "there's no question that pacification is either 90 percent or 10 percent security, depending on which expert you talk to. But there isn't any expert that will doubt that it's the first 10 percent or the first 90 percent. You just can't conduct pacification in the face of an NVA division." Nor could you conduct it in the face of an entrenched and active Viet Cong infrastructure, and that was the other end of the spectrum. Timely and coordinated intelligence was the key.

Major General (later Lieutenant General) Phillip B. Davidson had the interesting experience of being MACV J-2 (Intelligence Officer) during the last year General Westmoreland commanded American forces in Vietnam, then continuing

in that post for the first year General Abrams was in command. Davidson was thus in a position to offer some interesting comparative insights into the importance accorded intelligence and its use in the early and later periods of American involvement.

In early October 1968, Davidson told a high-level visitor: "I think the intelligence is many times better than it was six months ago." He attributed this to several factors: "In the first place, the break-through that we got on infiltration gave us a great lead on the enemy we never had before."

There he was referring to an extremely important development in signals intelligence, the newly-acquired ability to intercept and decrypt message traffic detailing enemy movements down the Ho Chi Minh Trail so that, as General Abrams once remarked, they could "arrange a proper reception for them."

And, said Davidson: "For the first time, there are agents placed in the right places, and they are giving invaluable information. I think our analytic capability has increased immeasurably over the last few months." Also the benefits of MACV's computer capability were just beginning to be felt.

A couple of weeks later Davidson told a regional conference on intelligence collection: "The Commander is pleased with his intelligence, acts upon it, and has forced the staff to act upon it—that is what has changed in the last four or five months. I think," Davidson continued, "unquestionably one of the things that's caused success is communications intelligence, perhaps the biggest."

But also: "I think the most dramatic proof has been the breakthrough in the high-level agents. The COSVN guy, the A-22, Superspook, 23, 24—the guys that are really giving it to you the way it is! You don't have to say, 'Gee, I wonder if this is right or not.' You know that guy's telling you the truth." Someone commented, "That's something ARVN's done," to which Davidson responded, "That is an ARVN contribution first rate, you're right."

The crucial importance of intelligence as viewed by Abrams was articulated when General Charles Bonesteel, then commanding US forces in Korea, visited Saigon. Bonesteel asked, regarding intelligence: "Which is—what—half the game over here?" Abrams: "W-e-l-l, sometimes I get it up around 90 percent. But I've never gotten below 50! This is your lifeblood. It's your lifeblood! When I look back on my service, and especially my times in the Pentagon, I wish I had seen this as clearly. And I regret it."

But, added Abrams: “I think the intelligence corps, the branch, and the quality has really been functioning. We’re getting some fine talent. Another place that I think they’re strong—there’re some warrant officers in these radio research units that are really first-class professionals. Been at it a long time, and they’re dedicated to it.” And now: “The field is far more up on the step on intelligence than they were then [in 1967, when Abrams first arrived]—far more.”

In a session with his senior subordinate commanders, Abrams stressed that “everything good that happens seems to come from good intelligence. A lot of this galloping around produces nothing because the intelligence [is lacking].” And in a conference with General Cao Van Vien, Chief of the Vietnamese Joint General Staff, Abrams said of the application of airpower, “I think the targeting keeps improving. That’s very important. If the targeting is of good quality, then it lands on the enemy or his supplies. No good to land in the jungle, you know— nothing but monkeys or elephants. That’s all intelligence—it’s the only way.”

Incidentally, there was some real continuity in the top intelligence billet in Vietnam once General Bill Potts took over the job. General Abrams told Potts that he was going to be J-2 for as long as Abrams continued in command, and so he was, outlasting in the process five MACV Chiefs of Staff, seven J-3s, and six J-4s.

### **Chunk 5: Components of Vietnamization**

Broadly construed, Vietnamization encompassed a large number of diverse but mutually reinforcing programs and policies, all related to security assistance in one form or another. I will mention a number of them and amplify on a few. We can talk about others, if you wish, later on.

- **Phoenix:** This program was designed to identify and root out the covert enemy infrastructure which, through terror and coercion, kept South Vietnam’s rural population under communist domination. It was, in its most basic elements, an intelligence operation.

Critics of the war denounced Phoenix as an “assassination” program, but the reality was otherwise. For one thing, captives who had knowledge of the enemy infrastructure were invaluable intelligence assets. The incentive was to capture them alive and exploit that knowledge.

Congressional investigators who went out to Vietnam to assess the program found that of some 15,000 VCI neutralized during 1968, 15 percent had been

killed, 13 percent rallied to the government side, and 72 percent were captured. Of those killed, many were engaged in regular combat at the time.

• **Pacification:** The role of President Thieu was key to the success of pacification. General Abrams observed that Thieu “knows more about pacification than any other Vietnamese,” while Bill Colby called Thieu “the number one pacification officer” in the country. His personal involvement made the program go. He was all over the country preaching the importance of pacification to support officers and administrators, and when newly-elected village and hamlet officials were brought to Vung Tau, converted into a training center for government administrators, President Thieu addressed every class. This gave local officials the incomparable cachet of being able to return to their home villages and say “as President Thieu said to me at Vung Tau—.”

There came a point at which the term “pacification” was viewed as outmoded (if it ever was appropriate) and was replaced with “Rural Reconstruction and Development” and then “Community Defense and Local Development.” This reflected, contrary to claims of the anti-war element, the undeniable fact that the vast majority of South Vietnamese preferred life under their own government, no matter its shortcomings, to what loomed under communist rule.

In document after document the enemy kept predicting and calling for a “popular uprising” amongst the South Vietnamese, but in fact there was never any popular uprising in support of the communists in South Vietnam. To any objective observer that does not seem too surprising in view of the enemy’s record, year after year, of assassinations, kidnappings, terror bombings, impressments and indiscriminate shellings of population centers throughout South Vietnam, actions hardly calculated to win the hearts and minds of the victims. The boat people constituted a final referendum on how the people of South Vietnam viewed their invaders and tormenters.

Hanoi’s official history of the war acknowledges the effectiveness of the pacification program. “...after many years of ferocious, continuous combat, especially during 1972,” wrote its authors, “our local armed forces had suffered rather serious attrition. The enemy’s efforts to carry out pacification, gain control of the civilian population, draft troops into their army, and force youths to join the People’s Self-Defense Force caused us a great many difficulties.”

In retrospect, the term pacification was a misnomer. The vast majority of the population did not need to be pacified. It was not, in general, in opposition, armed or otherwise, to the government. As the arming of local defense forces illustrated,

and the loyalty of the populace and the military forces at all levels during the severe test of the enemy's 1968 Tet Offensive further established, the people by and large were not in opposition. What was going on in the innumerable village programs throughout the course of the war was not pacification but building of defenses, security arrangements, and economic programs that would sustain the population through the difficult period of conflict.

• **Territorial Forces:** These were the Regional Forces (under province control) and Popular Forces (under district control). In 1970 these elements were integrated into the Regular Forces, where they constituted more than half the 1.1 million men under arms.

The Territorial Forces were given first priority by Abrams for issue of the M-16 rifle. During the earlier years of American involvement South Vietnamese forces generally, and especially the Territorial Forces, stood in line behind US units and other allies for modern weaponry. While the enemy was being armed with first-line communist weapons such as the AK-47 assault rifle, South Vietnamese were trudging around with cast-off US weapons of World War II vintage such as M-1 rifles and carbines. Noted General Khuyen, South Vietnam's chief logistician, "during the enemy Tet offensive of 1968, the crisp, rattling sounds of AK-47's echoing in Saigon and some other cities seemed to make a mockery of the weaker, single shots of Garands and carbines fired by stupefied friendly troops."

Abrams changed the priorities, putting the Territorials first in line. Expanded in numbers and better armed and better trained, the Territorial Forces came into their own, earning the respect of even so tough a critic as General Julian Ewell. "They were the cutting edge of the war," he said admiringly.

"By the end of 1968," recalled Vietnamese General Ngo Quang Truong, "the need to improve the effectiveness of RF and PF units had become critical; they were to assume the major responsibility of pacification support, replacing ARVN divisions which were taking over combat responsibilities from redeploying US units." A huge advantage of such forces, said Truong, was that "the local population could depend on these troops who would stay with them forever and not be redeployed to another area."

Truong also acknowledged the importance of General Abrams' interest in the progress made. "It was not," he said, "until the US interest in advising and supporting the territorials began to have an effect in late 1968 that definite improvements in RF/PF performance could be seen." And, concluded Truong, "throughout the

major periods of the Vietnam conflict...the territorial system...was aptly regarded as the mainstay of the war machinery.”

- **Regular Forces:** Better equipped and better coordinated, especially in terms of fire support, these forces progressively took over responsibility for the war from incrementally redeploying US and other allied forces.

- **National Police:** This element was expanded, moved to the countryside, and given the new (and historically unfamiliar) mission of protecting the people.

- **People’s Self-Defense Forces:** In April 1968 President Thieu, against the advice of virtually all his advisors, activated what was called the People’s Self-Defense Force. Thieu argued that “the government had to rest upon the support of the people, and it had little validity if it did not dare to arm them.” Ultimately some 4,000,000 people, those too old or too young for regular military service, became part of the PSDF, armed with 600,000 weapons (which they took turns using). Probably more important than any military capability represented by these forces was the overt commitment to the government represented by this participation.

- **Local Elections:** Hamlet and village officials were once again locally elected rather than being appointed by the central government.

- **Training Local Officials:** Newly elected village and hamlet officials were brought to Vung Tau, where the training center had been converted to a school for government administration.

- **Land Reform:** In 1970 President Thieu introduced a program known as “Land to the Tiller.” Its goal was to give every peasant title to the land he farmed. Under the program, the government would buy up large amounts of land and distribute it free to the families who had been working the land as tenant farmers for absentee landlords. By 1972 the program had given over 400,000 farmers title to 2.5 million acres of land. “In one fell swoop,” said John Paul Vann, the program “eliminated tenancy in Vietnam.”

- **Currency Reform:** Painful but effective measures to curb inflation were taken by the Thieu government.

- **Miracle Rice:** Rice is the be-all and end-all of the Vietnamese economy and culture. During the 1968-1969 growing season some 35,000 Vietnamese farmers were introduced to new high-yielding rice varieties such as IR-8. Its average yield per hectare was more than five metric tons, compared to an average yield of two

metric tons for local varieties. The new strains also permitted multiple plantings each year. The net production increase for the year was 132,000 metric tons of unmilled (paddy) rice. As improved security permitted more land to be planted, and more and more farmers planted the new strains, rice production soared.

- **Chieu Hoi:** This was an amnesty program which welcomed communists who wanted to come over to the government side. As combat operations became more effective in securing the rural population during the Abrams years, the Chieu Hoi program prospered accordingly. Noted General Phillip Davidson, the MACV J-2, “your Chieu Hoi rate goes up not as a result of sweeps, but as a result of getting in an area and staying in it.” That was an endorsement of “clear and hold” versus “search and destroy.” The number defecting to the government reached its peak in 1969 at 47,000, the equivalent of several divisions, and remained very high in 1970 (32,000). After that most of the potential had been harvested.

## Results

That completes the chunks. Let me now sum up the results of this approach to security assistance. The legendary John Paul Vann, usually an extreme critic and therefore credible when speaking otherwise, summed up the results of the latter-years approach to conduct of the war. “We are now at the lowest level of fighting the war has ever seen,” he said in January 1972. “Today there is an air of prosperity throughout the rural areas of Vietnam, and it cannot be denied. Today the roads are open and the bridges are up, and you run much greater risk traveling any road in Vietnam today from the scurrying, bustling, hustling Hondas and Lambrettas than you do from the VC.” “This program of Vietnamization,” added Vann, “has gone kind of literally beyond my wildest dreams of success.”

Compatible judgments were formed on the enemy side as well. This is from the official PAVN history of the war:

“After the Tet general offensive and simultaneous uprisings, our armed force in South Vietnam conducted two subsequent offensives in the summer and fall of 1968, killing a number of enemy troops and destroying additional implements of war. However, because we did not fully appreciate the new schemes and the changes made by the enemy in the way he was conducting the war, and because we underestimated the enemy’s capabilities and the strength of his counter-attack, when the US and its puppets began to carry out their ‘clear and hold’ strategy our battlefronts were too slow in switching over to attacking the ‘pacification’ program, and we did not concentrate our political and military forces to deal with the enemy’s new plots and



schemes. Beginning in the latter half of 1968 [note this enemy endorsement of the point at which the break between earlier and later periods of American involvement should be placed], our offensive position began to weaken and our three types of armed force began to suffer attrition. The political and military struggle in the rural areas declined. Our liberated areas began to shrink. COSVN main force units and the main force units of the military regions could only maintain a portion of their forces in our scattered lowland base areas. Most of our main force troops were forced to move to the border areas or to bases in the mountains.”

Later there came a point, of course, at which the war was no longer won. We can discuss that and the reasons for it shortly if you wish.

### **Summary**

In summary, the key elements in the success of Vietnamization, the result of intelligent and effective security assistance to the South Vietnamese, seem to me to be the quality and continuity of top leadership; effective intelligence; a realistic insight into the nature of the war and how it should be conducted; and development of implementing programs that the South Vietnamese adopted as their own and prosecuted effectively with reliable and consistent American security assistance.

I am grateful for the privilege of addressing you and would now welcome your comments or questions. Thank you.



## **Featured Speaker Question and Answers**

(Transcript of Presentation)

### **Dr. Lewis Sorley**

#### **Audience Member**

Thank you, sir. You've studied extensively and written about three of the greatest generation, that being Westmoreland, Abrams, and Harold K. Johnson. Forty years from now, what will historians be saying about the four-star leadership that the Army has had in the last ten years?

#### **Dr. Lewis Sorley**

Well, you know, that's a nice thing to do to a speaker is right away drag him out of any area of expertise he might have and ask him to comment off the cuff on something else. Well, at the risk of embarrassing some of our participants here, I will say that I was on the Charlie Rose program not long ago with two other officers, and a similar question was put to me. I said that I could not pose as an expert on current leadership, but that I happened to know two people who were involved in the war in Iraq, and those two people were David Petraeus and H. R. McMaster, and that I admired them very much indeed and I had great respect for what they were achieving. I may have gone a step further and said that I loved them very much, which is also true. I don't know about the others. I think I also said something very favorable about General Rick Shinseki, for whom I also have great admiration.

I have a few friends in the media, one of them is Tom Ricks, who has just published a book titled Fiasco, which you know, is not about the entire war. I think it's a little like a lot of the things that were written about the Vietnam War, that they sort of ended before the latter years. I gave the statistics on that to Bill Colby once and he published a great Op Ed piece, which said that the books by Sheehan and Herring were like books about World War II that would end before the D-Day Invasion. I think that Ricks' book may end before the glory days of this encounter, but one time Ricks called me up and he told me that he was going to have a one-on-one with the Deputy Secretary of Defense, Paul Wolfowitz. He asked me for some questions. I said, "I'll give you one question. Ask Mr. Wolfowitz if he now thinks General Shinseki had it right." I think he asked him that, but I'm not sure that he got an answer, because in the subsequent article that didn't show up. I'm not competent to comment on the current generation of leadership. Also, you implied in your question what I think is right, some years are probably going to have to pass before we are fully able to evaluate how effective they were and how admirable they are.

I will say this, you used the term “greatest generation.” I’m now working on a Westmoreland biography, as my introducer said to you. I have some ways left to go on that. To be quite candid, I’m probably reaching the end of the line here as a productive scholar. But if I last long enough, I’m going to do one more book, which will sort of be a one volume history of American involvement in the war in Vietnam and alluding to the so-called “greatest generation” of World War II. Which I don’t quarrel with. My father was a soldier in that war and I’m very proud of him and his colleagues. But I plan to call this book *Also Great*, and some subtitle about the generation that fought the Vietnam War.

### **Audience Member**

Thank you, Doctor, and I certainly do hope to read your book after that, as well. After the Westmoreland book. This is in the nature of a comment on the controversy over ‘67 versus ‘68. When I was preparing my paper, I used Robert Komer’s book, *Bureaucracy Does It’s Thing*, in 1972, and what struck me about that book when I was reading it, long before you described in such admirable detail, the controversy of ‘67 versus ‘68. He wrote that four years later than ‘68, and yet what struck me there was the sense of resignation, that this is always going to be the case, that the bureaucracy was at fault. Bureaucracy can’t be changed. We might as well throw up our hands. We might win this war, but there was no recognition whatsoever of any change from ‘65 versus ‘68. That really ... if he himself wasn’t aware of a change four years after the change occurred, then he obviously didn’t institute it.

### **Dr. Lewis Sorley**

Mr. Komer will never be found undermining his case for his own greatness. But I think that you have, as an historian, an obligation to first of all, vacuum up all the evidence you can find. If it takes you in a different direction than you thought you were going, then that’s where you should go. I think that the bureaucracy is one thing, and the bureaucracy in the Vietnam era was a very difficult one in every respect. From the ... I’m going to use this term on purpose. You may not agree with it. From the cowardice of the senior leadership at the Pentagon level in uniformed leadership, and especially General Earl Wheeler. Failing to stand up to the civilian leadership and make appropriate cases for doing this the right way. The bureaucracy was not an admirable thing. You had the convoluted chain of command that the commander in Vietnam had to go through, and the fragmented control over the air war. All of those things made it much more difficult to do the right thing.

But here’s the thing about the conduct of the war in Vietnam that a lot of people are not aware of, but is absolutely right, people know about what we might characterize as the over control of the war by the people in the White House, for example.

They know about the picking of bombing targets at the Tuesday lunches, and that kind of micro-management. All that is true. That's well documented and you can't argue that it didn't happen. But the contrary fact is very interesting to me because I'm focusing on the commander in Saigon, is that the conduct of the war within South Vietnam itself was left almost entirely to the commander on the ground. General Westmoreland says very candidly in his own memoirs that he decided on a war of attrition. Nobody told him to do that. He decided that was the only way to conduct this war. When General Abrams took command, as I quoted to you, the tactics changed within 15 minutes of Abrams taking command. He didn't have to go to anybody else and say, "Can I do this?" and he didn't. That wasn't his style anyway. He would do it, and if they wanted to reign him in, they could. So the bureaucracy operated in not benign ways at the levels where it was impacting the conduct of the war. But inside South Vietnam, with the exception of certain rules of engagement, which largely had to do with what weapons systems could be employed and in what circumstances, there was pretty much of a free hand for the commander.

#### **Audience Member**

Dave Chuber from US Army Chemical School. I'm sort of delighted to hear your assessment on the Intelligence System in Vietnam, but could you elaborate a little bit on the success and development of the American human intelligence (HUMINT) program.

#### **Dr. Lewis Sorley**

Let's see if I know anything worth saying about HUMINT. The only thing that comes to mind, I'm not probably an expert in that, is that in the Phoenix program and other aspects of the elements of the program seeking to root out the VCI, (Viet Cong infrastructure), the people I talked about that were, you know, shadowy presences that were coercing the South Vietnamese, the intelligence was absolutely key to that. They set up a series of ... well, there were long initials for them. Something like DIOCC, District Intelligence and Operations Coordinating Centers. Some name like that. They did that at province level, also. But what made them more effective was they gave them the communications to move the intelligence quickly when they got it and they gave them the incentive to understand that this is very perishable stuff and if you're going to harvest any good from it, you've got to move quickly, quickly, quickly. So that if they scarfed up some members of the infrastructure, identifiable, and interrogated them, they could then get what they learned from them out in time to do some good before the enemy realized, you know, this person had been compromised and they better move their agents and so on. That's about all I can think to say to that. Thank you.

### **Lieutenant General David H. Petraeus**

First of all, I'm sorry for coming in late, but just for everybody, I actually was hosting a change of command ceremony this morning. We moved it as quickly as we could, but still needed to do the right thing there. I must say, I was sort of struck ... you know, over time in Iraq, folks have continually asked, you know, "Is Iraq Vietnam?" And of course, the stock answer is, "Of course it's not Vietnam." As a good, perhaps sometime scholar, we all know that every case is unique and contextual and all the rest of that. Nonetheless, as we have prepared this Field Manual on counterinsurgency that is going to come out later this fall, it is very, very interesting how many sort of key ideas are common to both situations. I think you underscored a couple of those here today, just, I think, worth highlighting again. You know, Intel, Intel, Intel. Boy, I just cannot say that enough either. And the importance of that, therefore, being able to drive targeted operations rather than sweeps. We used to call them cordon and knock rather than ... in fact, if you really have the good Intel, you literally do just knock on the door because you know it sufficiently well that you have a sense of the atmospherics, that when someone comes to the door they're not going to blow up the house or put up a fight. Now sometimes they will, and you have to know that and you have to be ready for that. But it's so much nicer, of course, if you could do a cordon and knock as opposed to a big cordon and search or a big huge sweep.

The importance of host nation leaders. I think yesterday I implied, if didn't actually state explicitly that, you know, I think the assessment right now is that the key in Iraq is, literally is, the leaders at those four different levels that I discussed. But it was the same thing, obviously, in Vietnam. There's a certain distance that you can take another country, or a system, or help them get to, but then at a certain point, they've got to start carrying the rucksack for themselves. The importance of advisors and preparation of advisors. The importance of local forces. You know, the tradition of police in both countries being, not the pride and joy, not the most respected institution in the country, to put it mildly. So it's very, very interesting, again, that you have those. Of course there's some very, very big differences, I think. And I think one of those would probably be, certainly there were different sects ... certainly differences in religion, just for starters. And of course, you have the educated and the uneducated, the peasants and the ... but, I mean, the sectarian issues, of course, in Iraq, are far more substantial and perhaps bigger cleavages, at the very least have become so, certainly, particularly in the past eight months or so, or six months, since the Samara Gold Dome Mosque, which was really a tragic occasion.

**Dr. Lewis Sorley**

You know about ... you know about, of course, all the problems that the Buddhists created and this is not quite a parallel to the Iraqi situation because they are such a minority, but the problems with the Montagnards, as compared to ethnic Vietnamese, continue to be severe, if we're to understand the press accounts.

**Lieutenant General David H. Petraeus**

And the Catholic elite that speaks French and all the rest of that. But it never did not seem, in my approach, certainly of that in Iraq, and sadly, that, in Iraq, was not as bad, in my assessment, in the first year or so. There's actually an enormous amount of intermarriage. There's ... each tribe in Iraq actually has Sunni as well as Shiite, typically. And the tribes are not, by any means, exclusively, and in many cases, actually spill over into the Kurdish area. So again ... but, your talk here this morning actually really brought out some of these. And, as I said, so has this research that we've done for the Counterinsurgency Field Manual. So I guess let me just end this by saying thanks to you for what you have done as probably, at this point in time, I think the leading scholar who has done it sufficiently after those books that you cited earlier, which were contemporary history rather than later history. And with that note, let me give you something that talks about even longer service, which is three centuries of service, which Fort Leavenworth has rendered to our country. With our thanks, both for your scholarship with all these books, and your contribution to our Army in uniform too.

**Dr. Lewis Sorley**

Thank you very much. General Petraeus doesn't know that before he arrived I quoted him as saying that the biggest lesson is that everything is contextual. So whatever insights we derive from the Vietnam War, the importance is we derive correct ones, and then we can decide whether those have any applicability elsewhere. Thanks again for having me.





## **CORDS and the Vietnam Experience: An Interagency Organization for Counterinsurgency and Pacification**

**Dr. Richard W. Stewart—US Army Center of Military History**

This is a much shortened version of my National War College Research paper on US security assistance for pacification in Vietnam, and it is based on the entirely supportable premise that we still have a lot to learn from the US Army's largest, and, in many ways, most successful effort at nation-building with the possible exception of the conquest of the Philippines. Largest in terms of manpower—over 8,000 US advisors involved in pacification alone at its peak in 1968, not counting US advisors to the South Vietnamese Regular Army—in terms of time—over 15 years if you count the early Special Forces advisors, and in terms of treasure, all the billions we poured into that country especially from 1965 to 1973 which, in real dollar terms even compared with today, was a truly staggering amount.

Our involvement in pacification and counterinsurgency activities in Vietnam should thus provide us a wealth of experience that we can use today as we face similar problems in Reconstruction and Stabilization activities, and yet, with a few notable exceptions, Vietnam is only slowly being examined for lessons, good or bad. The United States Army, in my opinion, virtually turned its back on its counterinsurgency and pacification experience in Vietnam as soon as it possibly could and consigned the mountains of data and painful experiences to the ash heap of history. But we can still mine that heap of experience, as Bob Sorley has reminded us this morning, and learn from it: from the good, the bad, and the ugly of Vietnam.

My research paper focused on the establishment of an interagency headquarters in South Vietnam, headed by a single manager to control the entire US support effort to the Vietnamese pacification/counterinsurgency struggle, and the placement of that manager within the US military chain of command. This combination of interagency coordination and clout, under a single individual, a civilian yet within the military chain of command and incorporating military and civilian managers of programs, resulted, in my opinion, in a much more efficient and effective use of US security assistance assets for pacification than had existed before. This initiative, coupled with major enemy mistakes, especially during and immediately after the Tet offensive, went a long way to set the stage to essentially win the pacification struggle in Vietnam, even if it was unable to insure the long-term survival of that nation.

That headquarters was CORDS, Civil Operations and Revolutionary Development Support, in existence from May 1967 until the signing of the ceasefire in January 1973. CORDS was an attempt to bring the critical elements of territorial security, economic development, good governance programs, national police programs, and tactical psychological operations to encourage enemy deserters, under one civilian manager as part of MACV, with all of the access to the important personnel and materiel resources of that headquarters. I'd like to take a brief look at the CORDS organization, discuss the pain of its creation, touch on how successful I believe that it was, and then end with a few sweeping generalizations on what I think we can learn from it.

### **Organization**

CORDS was not the obvious first choice for an organization to fight the “other war” as McNamara and Johnson called it. Churchill used to say that the United States can always be counted on to select the right course of action after it had exhausted all other options. This was certainly true with CORDS. It was established in mid-1967—two years after major combat operations began and after two previous organizations for pacification had proven to be inadequate to the task.

Since the early 1960s, the pacification effort in South Vietnam consisted of a number of disparate programs including international development aid run by AID and USDA, a small advisory effort supporting good governance also under the AID aegis, and a modest counterinsurgency/counterinfrastructure/pacification effort run by the CIA. These programs were all managed loosely by the embassy using the Country Team Method. The Ambassador, more often the Deputy Chief of Mission, was the chief “coordinator” of these efforts, but no one was in overall charge. Even as the American aid effort and presence grew, two successive ambassadors—Henry Cabot Lodge and Maxwell Taylor—despite pressure from Washington, insisted on the embassy filling the role as coordinator of pacification, rather than director over the various pacification programs.<sup>1</sup> Even the establishment of a Joint Headquarters, MACV, did not bring unity to the effort since the military kept their focus firmly on providing advisors to the conventional armed forces of South Vietnam that were only partially involved in pacification activities. The personnel in the US civilian programs did not communicate with the military nor even among themselves very well; each decision reached by “coordination” in Saigon could be overturned by each agency appealing back through its direct pipeline to Washington. As General Westmoreland later stated in his memoirs, “The US Mission was Washington bureaucracy in miniscule, each agency reporting back to its parent agency and centralization occurring only in Washington in the person of the President himself.”<sup>2</sup>

Except for some general coordination at the Country Team level, the hundreds of US personnel from a variety of agencies engaged in pacification missions in the provinces did not work for any unified chain of command, did not communicate, were never working together in consonance with a plan, and thus there was no coherent US approach to what were often overlapping programs.

As the US support to pacification programs grew in scope and funding, and especially as the US military presence grew in size, the embassy approach to “coordinating” the pacification support efforts became more cumbersome. With no central guidance or direction, or even a means to measure how successful or unsuccessful the programs were, decision makers in Washington grew uneasy about this “other war” even as our main force units were beginning to take the conventional fight to the enemy in 1966 and 1967.

Anxious to see success, President Johnson began pushing the embassy to provide more centralized direction and control and more tangible proof of progress. When this management approach was resisted by the various ambassadors, he then intervened and directed the establishment of a new office, the Office of Civil Operations (OCO). He further ordered that it be placed under the Deputy Chief of Mission in the embassy who was to give the office his full time and attention. The embassy placed all of the US pacification programs except the military advisory effort in the new office, but it took months to get the key program management positions filled with civilians. Johnson, who had only given the OCO some 90 to 120 days to show progress, directed the establishment of CORDS in May 1967, placed it under MACV rather than in the embassy, and consolidated almost all civilian and military pacification efforts in the new office.<sup>3</sup> To run it, Johnson appointed his former Special Assistant for Pacification, Robert Komer, as Deputy for CORDS directly under General William Westmoreland, and empowered him to show results—to put “coonskins on the wall”, as he put it in his own colorful way.<sup>4</sup>

Komer, a colorful character himself with the well-deserved nickname of “Blowtorch Bob”, had the organizational skill and the ear of the president, and quickly established and enforced his priorities for the new organization. He focused his attentions on improving US support to pacification in three areas: territorial security, centralized US and Vietnamese planning, and counter-Viet Cong infrastructure operations.

Working closely with General Westmoreland, Komer almost immediately obtained the assignment of an additional 2,331 military advisors to pacification support to advise the Regional Forces/Popular Forces militia, the forces bearing the brunt of the security struggle for the control of the provinces. Before the creation

of CORDS there had only been some 141 US personnel assigned to advise these units, only 1 US advisor for every 929 of the “Ruff/Puffs”. This compared very unfavorably to the ratio of 1 US advisor for every 23 ARVN soldiers.<sup>5</sup>

The new advisors were organized into six man Mobile Advisory Teams (MAT) and smaller Mobile Advisory Logistics Teams (MALT) to provide advice and assistance to the Ruff/Puffs. These advisors immediately institutionalized a comprehensive training plan for the militia, slowly but surely improving their overall skill and readiness levels. They also set in train a program to convert their weapons from aging M-1s and M-2s into modern M-16s so they could more easily take on the AK-47 armed VC.<sup>6</sup> Before this, they were seriously outgunned. In addition, the South Vietnamese government, as a result of CORDS prodding, slowly but steadily expanded the size and mission focus of the Ruff/Puffs, building them up from 300,000 in 1967 to 517,400 by 1972; this made them larger than the regular army. The Regional and Popular Forces became much better trained, better armed, and better led, and were major factors in expanding and maintaining government control in the countryside.

Komer next forced US and South Vietnamese planners to sit down together and generate comprehensive pacification plans that integrated the allied military effort with the provincial development, security, and police efforts. There had been no serious planning effort before CORDS to meld all the efforts of US agencies together, with their Vietnamese counterparts or with the US or South Vietnamese military effort. For the first time, CORDS institutionalized joint, combined, and interagency planning with milestones, measurements, and resources linked to goals—ends, ways, and means across the entire civil-military spectrum. This planning effort had the additional benefit of forcing the Vietnamese to reorganize their own pacification agencies and effort to match that of the US

Komer also moved aggressively to expand the National Police and National Police Field Forces and their intelligence capabilities, the Provincial Intelligence Coordinating Committees (PICC) and District Operations and Intelligence Coordinating Centers (DIOCC) so that these elements could focus on attacking the VC “shadow government” in the countryside. The National Police expanded from 60,000 to almost 80,000 strong by the end of 1968, with much improved equipment, communications, and intelligence assets.<sup>7</sup>

Tied to this same intelligence structure was the other part of the anti-infrastructure campaign, the Vietnamese Phung Hoang, or “All Seeing Bird” program created in 1967 which tried to combine actionable intelligence with police and military strike forces. The US support to this program, orchestrated by the CIA, was

called Phoenix. This program gained an unsavory (although not entirely deserved) reputation, as an assassination program, but its primary focus was on capturing and interrogating VC shadow government members rather than killing them outright. Over 80,000 members of the Viet Cong Infrastructure (VCI) were caught or killed between 1967 and 1973.<sup>8</sup>

CORDS's focus on the territorial security mission and the dramatic expansion of the Regional Forces and Popular Forces played no small role in a dramatic erosion of enemy presence in the countryside between Tet and the Easter Offensive. Despite the steadily shrinking presence of US combat units in Vietnam starting in 1968, RVNAF, regular and militia, strength and competence in the provinces was on the increase. In addition, after Tet, these forces were augmented with a new People's Self-Defense Forces (PSDF), that grew to nearly 4 million members by the end of 1972. While most were little more than auxiliary "citizen's watch" type guards, 200,000 of these forces were armed and had received some training, providing a useful auxiliary force and additional "eyes and ears" in the villages.

In addition to a massive increase in the number and quality of security forces and police, CORDS assisted the government of South Vietnam in expanding and improving the training of Revolutionary Development (RD) cadre. The Revolutionary Development program was started in 1965 by then Prime Minister Nguyen Cao Ky, building upon previous attempts to send government officials out to hamlets and villages in the provinces. RD teams consisted of 59 young men and women, trained in rural development and principles of government at the National Training Center at Vung Tau, and were sent out into the countryside to show the people that the government was working for them. They were to live in the villages, coordinate aid projects, help dig irrigation ditches, set up local councils, establish local self-help and self-defense groups, and other "good governance" duties. They were to be a "revolutionary" vanguard that would counter the "revolutionary" VC by showing that the government could reform itself and bring progress to the countryside, thereby undercutting the VC appeal. Hundreds of these teams were formed and sent into the countryside, with the entire program consisting of almost 50,000 cadre at any one time.<sup>9</sup> It was a massive, and truly revolutionary undertaking in bringing government and organized development aid to the people.

With more security forces, and more layers of responders to enemy operations in the countryside, South Vietnamese government and US economic development programs expanded rapidly after Tet, giving the VC virtually no chance to recover their losses or prestige.<sup>10</sup> According to one scholar of the period, the insurgency was "on the ropes" due to this combination of slow but effective counter infrastructure attack, growth of government security forces, and expanded aid and governance

programs in the countryside.<sup>11</sup> US and especially South Vietnamese efforts were “steadily dismantling Viet Cong control in the countryside.”<sup>12</sup> The VC, given their high losses during Tet and the resurgence of the government in the countryside, was no longer the major threat to the stability of the government.

### **Measuring Success**

Having energized these programs, Komer, and later his successor as head of CORDS William Colby, took a CIA developed program to measure success called the Hamlet Evaluation System (HES), and applied it to the entire pacification effort in each of the 4000 + hamlets in the 44 provinces of South Vietnam.

I want to take a moment to discuss the Hamlet Evaluation System as a means to measure success since we are having similar debates today: how do we know if we are winning the stabilization struggle? In my opinion, the much-maligned HES was a valuable management tool that had shortcomings but went a long way to give a sensing of progress, if not of victory.

The HES, while subjective in nature and not entirely to be trusted at a single point in time, was a valuable management tool that assessed, over the long run, relative changes in the security posture of a province. It relied on specific answers to a series of 18 questions on enemy activity; government programs; development progress; territorial security forces status; security perception; infrastructure status (both roads and irrigation infrastructure and the enemy’s infrastructure) and general conditions in each hamlet in the country each month. Each hamlet would be assigned a code letter from A: government secured. B: and C: (mostly secure) D: and E: (contested) down to V, or totally controlled by the VC. Over time, despite the inevitable subjectivity of some of the province and district advisors who were to fill out the report, the HES provided a series of indicators on overall hamlet and provincial security. Flawed, yes, but it was certainly better than any other measurement of success available, such as the body count measurement, (and much more systematic and accurate, may I say, than today’s highly subjective Red, Amber, and Green system that seems to be applied today in Afghanistan with no discernable methodology.) Its main weakness, that no amount of data collection could overcome, was that it was unable truly to measure the degree of trust the South Vietnamese people actually had in their own government and their willingness to actively support and fight for their government. It was, nevertheless, a valuable tool that sought to collect a number of data points to measure progress.

## How Successful was CORDS?

Using both HES data and historical information on the expansion and activities of various pacification programs, how successful was CORDS and the pacification effort it managed for over five years? In fact, I believe that it was quite successful, but a successful failure, given the ultimate result in Vietnam. Pacification alone, no matter how successful, could not overcome the attacks of the very conventional North Vietnamese Army.

I believe that CORDS achieved real, measurable success in the mission it was given: improve the organization and flow of US security and development assistance to the government of South Vietnam so that they could better control their provinces—it was still their fight to win or lose. From 1968 to 1972, hamlet security increased from around 60% of the hamlets in the country reasonably under the control of the government to 90% by the end of 1972.<sup>13</sup> This was achieved by a combination of the VC forces and infrastructure suffering serious losses—an estimated 40-45,000 killed during TET—and by the fact that a result of their offensive, the VC infrastructure became more visible in the provinces.

After Tet, the Regional Forces and Popular Forces and the counter-infrastructure elements of the *Phung Hoang*/Phoenix program bit deeply into the ranks of the exposed enemy. The *Chieu Hoi* program to encourage VCs to desert and come over to the government was equally successful, with official US figures reporting an estimated 125,000 defectors from 1968 to 1972. The VC and their NVA backers also, by some reports, suffered some 672,000 combat casualties in that period with actual VC estimated strength declining some 36% to around 120,000.<sup>14</sup> There seemed little question that the VC were on the run and that the government was slowly and steadily expanding its presence and effectiveness throughout the country. As proof, when the enemy launched a full scale attack on South Vietnam with armor in April 1972, they completely failed to overrun the country or spark a national uprising.<sup>15</sup>

In conclusion, CORDS, the “one stop shopping” headquarters for virtually the entire US support to the pacification effort, can take no small credit for achieving measurable success in Vietnam in the pacification struggle. It was the central organizing headquarters that brought US assets to bear on increasing government control over its own people and, in that sense, it did what it set out to do. It could not, by itself, guarantee the survival of the South Vietnamese government—some 20 North Vietnamese divisions put “paid” to that chance—but it did orchestrate an effective interagency effort that brought development to the countryside, established a basic security framework, and fought a tough guerrilla foe to a standstill. Sounds like success to me.

## **Lessons Learned: What can we learn from CORDS?**

Now, what can we learn from CORDS. Despite the very different circumstances and especially scale of today's counterinsurgency efforts in Afghanistan (the CORDS effort in Vietnam was probably a hundred times larger and more ambitious by almost any scale you can imagine—personnel, dollars, scope) there are some seven major lessons that we can learn from the experience of CORDS in Vietnam and perhaps apply today.

- Interagency is Hard!
- The Single Manager Concept is valid
- Planning is critical
- Security is essential, but is not enough by itself
- Only the military has the logistical assets for counterinsurgency
- Dynamic Leadership still matters
- Counterinsurgency is about the host country, not the US

### *Interagency is Hard*

One lesson we can learn from the struggle to establish CORDS in the first place was the intensity of the opposition to forging an interagency headquarters. It is hard to get the agencies of the US government to work together, let alone subordinate themselves to one central direction. In this case, the State Department under two separate ambassadors—including one retired General—fought bitterly the idea that any of its assets for development or pacification should fall under a military chain of command, even one headed by a civilian. Interagency cooperation was a sufficient solution for the ambassadors—an interagency headquarters under a single manager was indeed a “bridge too far” for them. Even after several rather broad hints from the administration, it took the highest level of intervention to change their minds. That CORDS was created at all was due to the direct intervention and personal commitment of President Lyndon Johnson who saw, as the single decision maker in the national security structure, that the previous organizations of the pacification effort were not effective. Nothing else was sufficient.

Once CORDS was created, it took continual direct involvement by Ambassador Komer and General Westmoreland to make it work, but within months of its creation, CORDS had accomplished what can only be considered significant progress in a unified pacification effort. As Komer later wrote,

It is significant that not until an organization was created to focus specifically on pacification as its primary mission and to integrate all relevant military and civilian agency efforts did a major sustained



pacification effort begin to take shape. The bureaucratic price that had to be paid for creating this military elephant and civilian rabbit stew was to put CORDS under the military. *Paradoxically, this resulted in greater US civilian influence over pacification than had ever existed before* [his emphasis]; it also powerfully reinforced pacification's claim on US and GVN military resources, which constituted the great bulk of the inputs after 1966.<sup>16</sup>

### *The Single Manager Concept is valid*

The power of the single-manager concept for pacification organization also cannot be overestimated. Unity of command and control—a central military concept, was essential to forging CORDS into a truly effective interagency headquarters. The battle to create CORDS was not won quickly or easily however. Even after Ambassador Komer was in position as Deputy MACV for CORDS—and a more dynamic and forceful Washington-savvy power-broker would be hard to find—the struggle was not completely over, and he had to fight any number of attempts to chip away at the CORDS structure, limit its scope, or keep additional pacification-related programs from falling under his sway. This effort was only compounded by continual challenges with gaining backing and financing from Washington.<sup>17</sup> The dynamics of the situation, however, demanded a centralized organization under the major military headquarters in the country. The size and scope of the pacification effort were too large and demanded much more manpower and resources than the small, though well-intentioned, embassy-oriented programs could deliver.

### *Planning is critical*

By placing almost all of the pacification-oriented programs under one headquarters and investing the single-manager with unprecedented access to resources, that manager had enough leverage to force the various agency pieces to draft, staff, publish, and implement, in conjunction with the South Vietnamese, a nation-wide pacification plan in 1967 for the upcoming year. That planning process also forced the South Vietnamese, who were the key to any eventual pacification success, to create pacification councils and agencies, coordinate and merge their plans with those of the US military and civilian effort. The US, in turn, was bound to coordinate more and more of their military actions and training efforts with the South Vietnamese, ensuring some measure of high-level military interest in pacification. Planning was no panacea, but CORDS jump-started the effort to focus attention and resources where they were needed, and gained greater US and South Vietnamese “buy-in” to the process.

*Security is essential, but not enough by itself*

Both of the main Deputies for CORDS, Komer and Colby, very quickly realized that the one area of pacification that was non-negotiable if there was to be any chance of success in Vietnam was security. Without security, no development plans, government “pep-rallies,” local elections, new irrigation ditches, or immunization schemes could succeed in making a better life for the people of South Vietnam or make them believe in the power of their own government.

By tying the struggle for security to CORDS, and tying CORDS to MACV, Komer was able to tap into the vast resources of a military headquarters that controlled over half a million men and enormous financial and logistical capabilities. He was able to obtain several thousand additional military advisors within the first year of CORDS’ existence to work with the essential security forces in the countryside—the much-maligned and neglected Regional Forces and Popular Forces. Although not able to face up to major attacks by main force VC or NVA regular units, the RF/PF were numerous (almost half a million at their peak) and pervasive in the countryside. Even more than the ARVN, the security struggle in the hamlets and provinces was fought by the RF/PF and Komer was right to put additional emphasis on their arming and training. With the right training and supervision, a national militia force (not a private, ethnic or religious army like the *Cao Dai* in Vietnam or the *Mahdi* Army in Iraq) can be one of the keys to winning the security battle in an insurgency.

*Only the military has the logistical assets for counterinsurgency*

The other key recognition by Komer and Colby was that logistical resources were important to many aspects of pacification. By working closely within MACV, CORDS personnel were able to obtain emergency supplies during the two main crises of the Vietnam War: the Tet Offensive and the Easter Offensive. They were able to free up emergency supplies, transportation, equipment, and money to support South Vietnamese initiatives to alleviate the refugee crisis, move military reinforcements around the country, provide communications assets, tentage, and even arrange for emergency monetary payments to the families of those South Vietnamese killed or wounded. Komer gained for CORDS a “seat at the military table” when decisions were made and resources were handed out, something that embassy-bound officials with a welter of disconnected development and pacification initiatives could not easily do. The pacification struggle in South Vietnam was so massive that only military assets could bring sufficient resources to bear on the problems faced.

*Dynamic Leadership still matters*

CORDS brought to the pacification fight another almost incalculable asset: focused leadership. Leadership not only at the center—Komer and Colby were exceptionally knowledgeable and committed leaders and managers—but at each level of the process. Komer and Colby worked hard to fill leadership positions with the highest quality military or civilian leaders they could find, gave them wide-ranging powers, assigned them various goals and targets (whether or not they were truly the right ones for overall success is another matter—they were at least measurable tools for management) and held them accountable. These leaders at province, military region, and in Saigon answered to one chain of command and worked according to one game plan. Interagency “coordination” and cooperation, no matter how collegial or well-intentioned, was insufficient in managing the “subsidiary corporation called pacification.”<sup>18</sup>

*Counterinsurgency is about the host country, not the US*

It was truly ironic that leadership was so critical to bringing US focus to the pacification effort, and it was the lack of depth in South Vietnamese leadership that was perhaps the greatest single factor in frustrating so much of that effort. Despite massive efforts at identifying and training thousands of leaders at the Vietnamese National Training Center and sending countless others back to the States to receive training as officers, managers, supervisors, and leaders, time and again the reports talk about failures of vision, corrupt local and national leaders, incompetence, and just sheer lack of capacity to understand what government and governance means. It was a lack that neither Komer, nor Colby, nor the entire massive CORDS effort could ever entirely fill—only the South Vietnamese could value this characteristic, seek it out, and grasp its essence. We could not do it for them, and the more we tried, it seems, the worse we made it. The counterinsurgency fight belongs to the host country, and the more that the US remembers that, the better we will be. It’s all about security *assistance*, not security *assurance*.

## Endnotes

1 See in particular Thomas W. Scoville, *Reorganizing for Pacification Support* (Washington, D.C.: US Army Center of Military History, 1982). Also see Dale Andrade and Lieutenant Colonel James H. Willbanks, "CORDS/Phoenix: Counterinsurgency Lessons from Vietnam for the Future", *Military Review*, March-April 2006: 9-23.

2 General William C. Westmoreland, *A Soldier Reports* (Garden City, NY: Doubleday and Company, 1976. p. 68).

3 It seems likely that some, more covert, CIA pacification support initiatives fell outside CORDS, and the Marine Corps rejected all attempts to move their Combined Action Platoons (CAP) under the CORDS umbrella. See William Colby with James McCargar, *Lost Victory: A Firsthand Account of America's Sixteen-Year Involvement in Vietnam* (New York: Contemporary Books, 1989, p. 189) and CMH CORDS Files, File Cabinet 77, CAPS and MATS, Sep – Nov 68.

4 See Hunt, p, 71, with his quote from The Pentagon Papers: The Defense Department History of United States Decisionmaking on Vietnam, Vol. 2, p. 552.

5 Robert W. Komer, *Bureaucracy at War: US Performance in the Vietnam Conflict*. (Boulder, Colorado and London: Westview Press, 1986).

6 NARA, RG 472, CORDS Historical Working Group, Box 5, RF/PF Evaluations September and October 1968.

7 Richard A. Hunt, *Pacification: The American Struggle for Vietnam's Hearts and Minds* (Boulder, Colorado: Westview Press, 1995).

8 Dale Andrade, *Ashes to Ashes: The Phoenix Program and the Vietnam War* (Lexington, Massachusetts: Lexington Books, 1990. p. 287). It is, of course, impossible to tell if all those killed were members of the VCI and these figures are as suspect as any other "body count" figures from the Vietnam War.

9 Hunt, p. 36.

10 Ibid, p. 253.

11 Andrade, *Ashes to Ashes*, p. 282.

12 Dale Andrade, *America's Last Vietnam Battle: Halting Hanoi's 1972 Easter Offensive* (Lawrence Kansas: University Press of Kansas, 1995, p. 21).

13 Hunt, p. 254.

14 Ibid, p. 253.

15 See especially Dale Andrade, *America's Last Vietnam Battle: Halting Hanoi's 1972 Easter Offensive* (Kansas: University Press of Kansas, 1995) and NARA, RG 472, CORDS Historical Working Group Files, Box 70, Evaluation of Pacification Studies Group entitled, "The Impact of the Enemy Offensive on Pacification", 5 October 1972.

16 Komer, *Bureaucracy at War*, p. 118. This meant that more military resources were poured into pacification as opposed to civilian resources, not in the sense of DoD pouring more money into pacification as opposed to conventional military operations.

17 See in particular a memo to Mr. James Grant, Assistant AID Administrator for Vietnam complaining about lack of support from Washington and about having to "fight for each dollar, sack of cement and body" with AID. CORDS Files in CMH, Komer Papers, Memo of 24 August 1967.

18 See Hunt, p. 100.

## Stewart Addendum: CORDS and the Vietnam Experience: An Interagency Organization for Counterinsurgency and Pacification

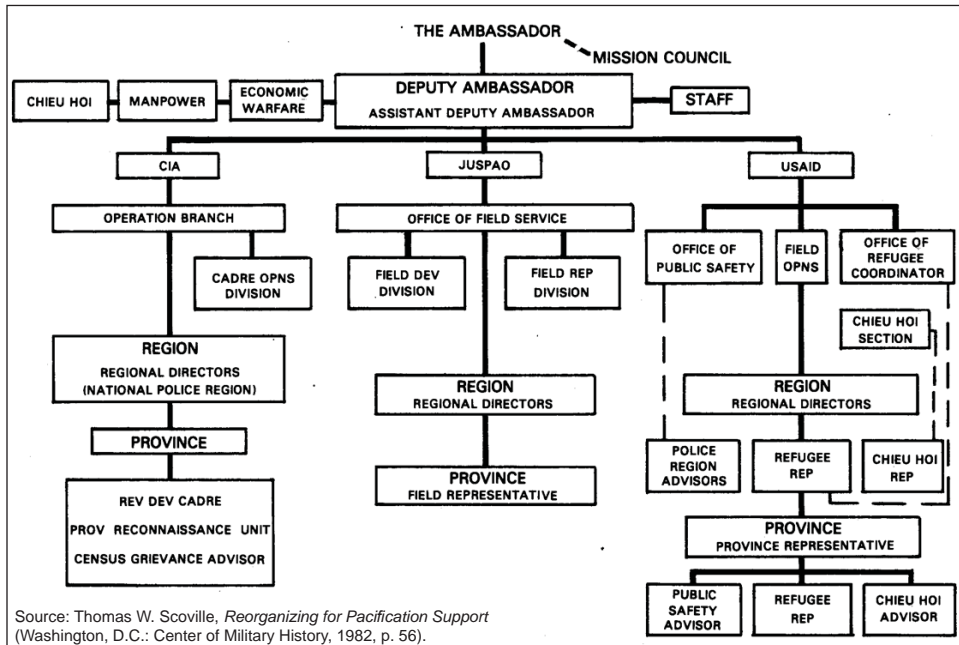

Chart 1: Organization of Pacification Support Effort Before CORDS.

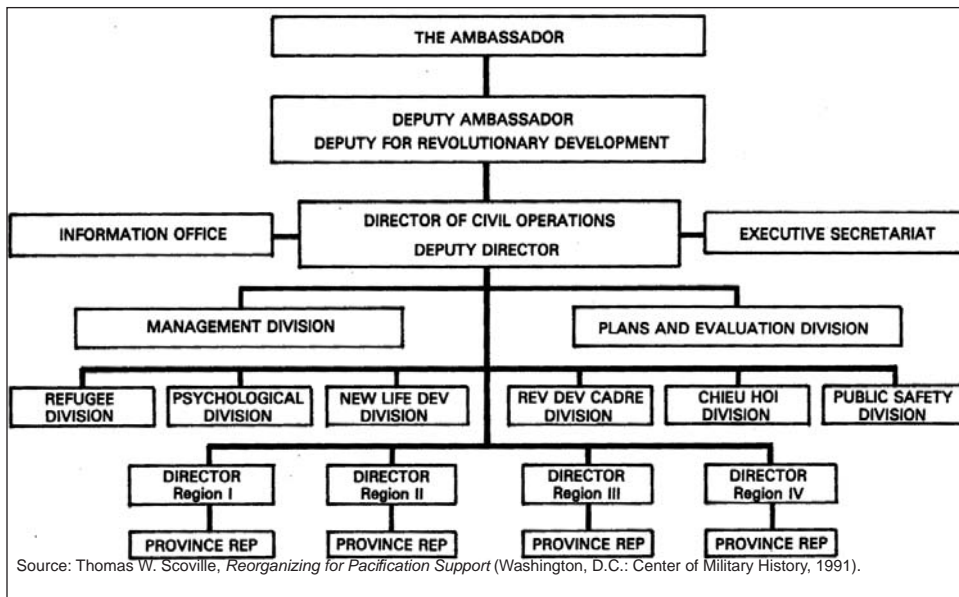

Chart 2: Office of Civil Operations (OCO) DEC 66-APR 67.

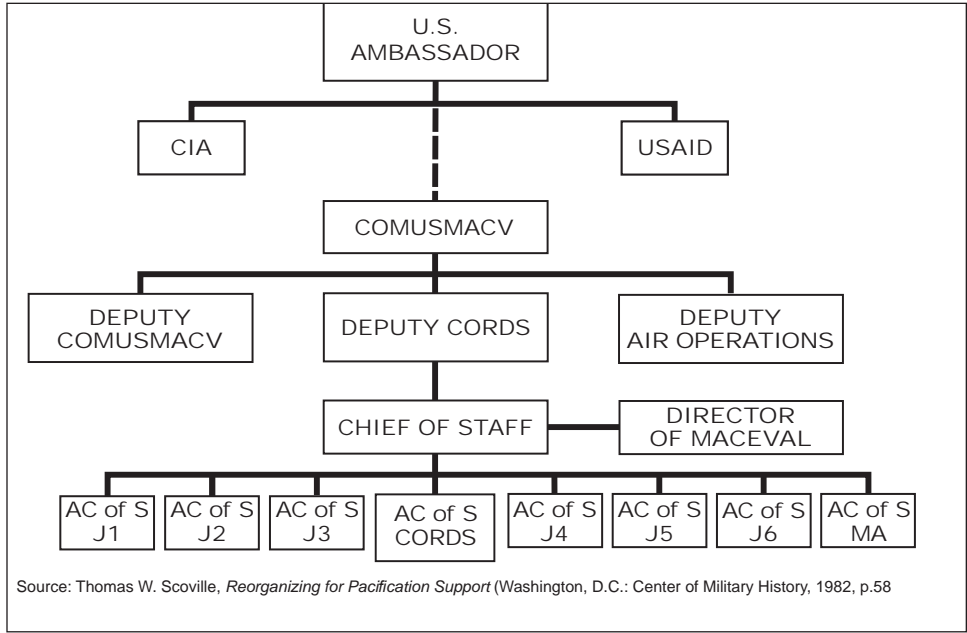

Chart 3: CORDS under the US Mission and MACV, May 1967.

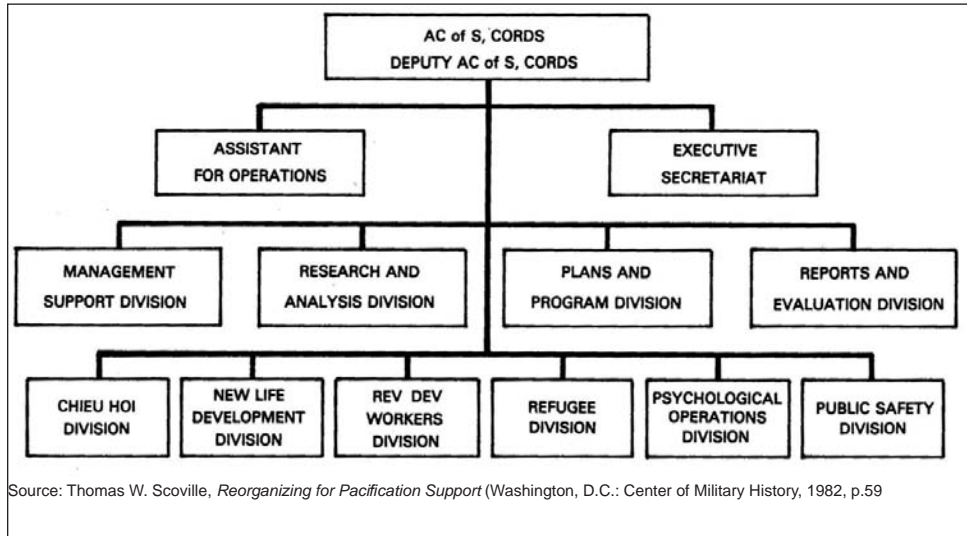

Chart 4: Organization of Assistant Chief of Staff for CORDS, May 1967.

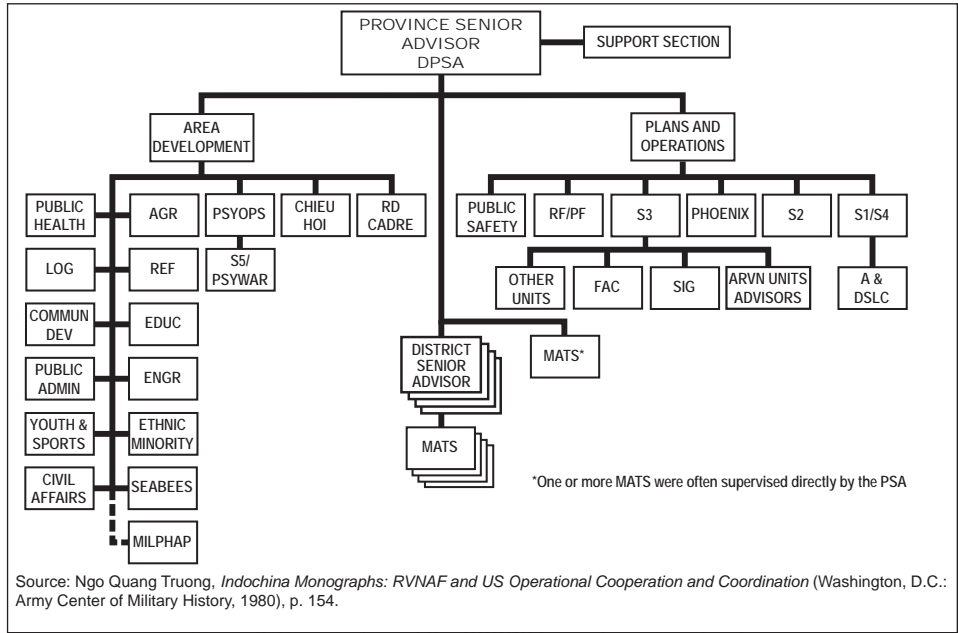

Chart 5: CORDS at the Province Level.

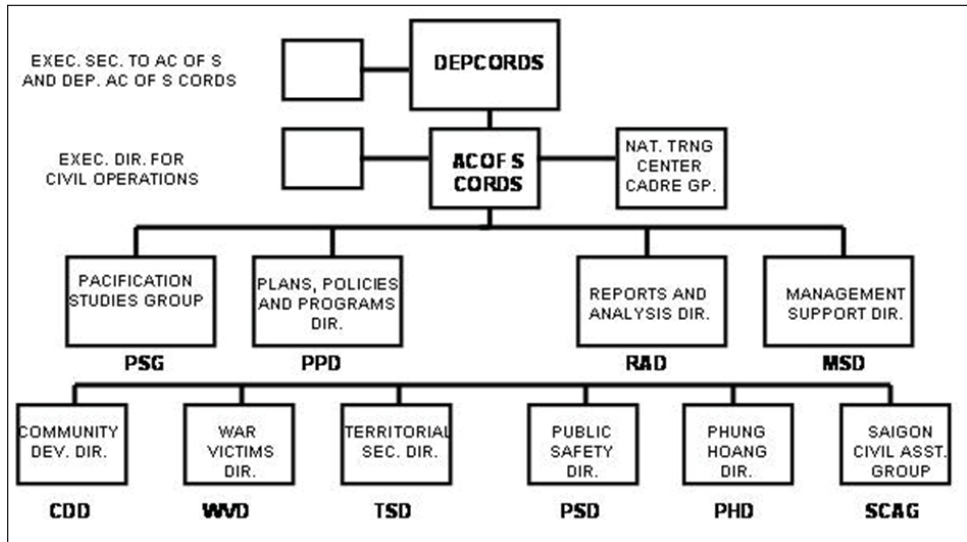

Chart 6: CORDS 1971-1973.





## **East to East: PRC Security Assistance to Tanzania, 1964-1976**

**Dr. Donovan C. Chau<sup>1</sup>**  
**Intelligence and Terrorism Analysis Group**

After its establishment in 1949, the People's Republic of China (PRC) quickly sought to establish relations with and influence countries around the world.<sup>2</sup> The African continent was one early focus of its attention, despite the PRC's lack of resources and infancy in international politics. While the PRC was active in North and West Africa as early as 1955, it was most successful gaining influence in East Africa—Tanzania, in particular.<sup>3</sup> The PRC used numerous instruments of grand strategy to gain lasting influence in Tanzania.<sup>4</sup> One essential instrument of PRC grand strategy was Security Assistance (SA).<sup>5</sup> The focus of this paper is on PRC SA to Tanzania between 1964 and 1976. Given the overall dearth of literature on the PRC in Africa, this paper will provide an historical understanding of PRC SA to a strategically located country in East Africa. In addition, it will demonstrate the PRC approach to SA more generally. Thus, this paper will shed insight on PRC SA in Africa—which is pertinent to analyzing and understanding SA in Africa today—and will help place PRC SA in historical and grand strategic contexts.

Supporting grand strategic objectives, PRC SA to Tanzania encompassed a broad range of measures through both overt and covert channels.<sup>6</sup> In addition to providing small arms and conventional military equipment, the PRC constructed military installations and bases on the island and the mainland. The PRC also provided SA in the form of training and doctrinal formulation. The recipients of PRC SA included regular and irregular military and security forces. Within the context of grand strategy, moreover, PRC SA was often combined with other grand strategic instruments. Therefore, it will be necessary to examine these political actions along with discrete, identifiable PRC SA operations. The politics of Tanzania and PRC SA will follow a chronological format primarily, beginning in 1964.

The Zanzibar revolution changed the fabric of Zanzibari society.<sup>7</sup> “In January 1964 the Zanzibar revolution exploded in East Africa, with vital consequences for the region as a whole. Among the immediate effects were the army mutinies of Tanganyika, Uganda, and Kenya which happened later the same month.”<sup>8</sup> The same month as the Zanzibar revolution, Tanganyikan soldiers on the mainland mutinied. In contrast to the Zanzibar revolution: “There appeared to be no direct evidence of Communist involvement in the East African troubles, as there was in Zanzibar.”<sup>9</sup> However several caveats could be made. For example, “The mutiny resulted in the ‘destruction’ of the British arms with which the Tanganyikan army

was equipped.”<sup>10</sup> Ambassador Ho Ying later argued that the newly developing state should not use scarce resources on arms and ammunition.<sup>11</sup> Instead, the PRC offered to replace British arms with PRC weapons—free of charge—including tanks, mortars, rockets, and other weapons. The PRC used propaganda to further the claim that the British were unwanted in Tanganyika. A Communist Chinese journal article portrayed British intervention in the East African army mutinies as a scheme “to stage a comeback” in the region. “In actions reminiscent of the days of the gunboat rule,” the article read, “the British colonialists used brute force to accomplish their ‘civilizing mission.’”<sup>12</sup> Furthermore, after the mutiny, it was reported that Tanzanian President Julius Nyerere became “highly suspicious of individual Westerners and especially of the UK and the US.”<sup>13</sup> Whatever its role in the revolution and subsequent mutinies, the PRC was able to take advantage of the political and security situations to its benefit.

On Zanzibar, the PRC wasted no time in establishing a presence on the island. In February 1964, Abdul Rahman Mohamed (known simply as “Babu”), formerly a correspondent of the *New China News Agency (NCNA)* who was at one point General Secretary of the Zanzibar Nationalist Party (ZNP), became Zanzibar’s Minister for External Affairs.<sup>14</sup> Babu worked with Communist Chinese envoy Liu Kan to secure PRC aid to Zanzibar. Communist Chinese aid to Zanzibar included an announcement of a \$518,000 grant as well as gifts of tractors, irrigation machinery, and “technical assistance.”<sup>15</sup> On 15 February, the PRC embassy opened in Zanzibar. Notably, the PRC ambassador had reportedly been selected prior to the Revolution, arriving with some Swahili-speaking staff.<sup>16</sup> The revolution reinforced the US Government’s assessment of a growing Communist presence. A State Department report on the world situation, submitted to the House Foreign Affairs Committee on 2 April 1964, listed Zanzibar as among the “critical points” subject to Communist influence.<sup>17</sup> Communist Chinese personnel were soon sent to Zanzibar to further PRC influence on the island. In early April 1964, Ambassador Meng Ying and five diplomatic staff flew from Kenya to Zanzibar. Ambassador Meng presented his credentials on 7 April.<sup>18</sup> At the same time, Minister Babu said technical experts from Communist China, the Soviet Union, Ghana, and the United Arab Republic would soon arrive in Zanzibar to help rebuild the country.<sup>19</sup> This evidence indicates that Communist China’s early focus was on the island of Zanzibar.

Expanding PRC influence on Zanzibar weakened other foreign influences, including the US position, on the island. In April 1964, the new Zanzibari government ordered the closure of a US tracking station, “to the advantage of the Chinese who secured some of the equipment.”<sup>20</sup> Although not fully detailed, this closure may have enhanced PRC technological capability through the acquisition of ad-

vanced satellite-tracking equipment. On April 7, President Karume summoned US chargé d'affaires Frank Carlucci to inform him that US bases in Zanzibar should be dismantled and removed. On both April 9 and 11, mass demonstrations were held opposing "US imperialism." President Karume addressed one event while members of the Revolutionary Council and leaders of mass organizations participated in the other.<sup>21</sup> The public display of animosity toward the United States, if not organized by PRC personnel, at least served PRC interests.<sup>22</sup> In related developments, the PRC continued to send personnel to the region. According to British sources in May 1964, twenty-four Communist Chinese carrying diplomatic passports landed from a freighter moored off Zanzibar Harbor.<sup>23</sup> "British official quarters were reported to be gravely concerned over recent moves by Peking that were believed to be designed to turn the island into a center of revolutionary subversion in the newly independent countries of Africa."<sup>24</sup> These developments on Zanzibar demonstrated Communist China's ability to take advantage of the political climate to serve its long-term interests.

By the middle of the year, the PRC had succeeded in face-to-face communications with the newly formed United Republic of Tanganyika and Zanzibar (Tanzania) government. From 10 to 19 June 1964, a joint government delegation led by Tanzanian Second Vice President Rashidi Kawawa visited Communist China and secured an interest-free loan of \$14 million for Tanzania.<sup>25</sup> The PRC gave another free grant of \$2.8 million to Tanzania.<sup>26</sup> Vice President Kawawa also negotiated other undisclosed economic and military agreements. He returned greatly impressed and overwhelmed by Communist Chinese capabilities and generosity. Serving as a guide for Vice President Kawawa was Zanzibar's former minister for external affairs, who, by this time, was a Tanzanian Minister of State for Economic Planning, Babu.<sup>27</sup> Babu's familiarity with the Communist Chinese was influential in the generosity of the financial assistance.<sup>28</sup> It was also reported that this was "a visit during which construction of the [Tan-Zam] railway was officially discussed for the first time."<sup>29</sup> Before departing Peking on 17 June, Vice President Kawawa said, "China is not only a great friend of the United Republic of Tanganyika and Zanzibar but also of the whole of Africa."<sup>30</sup> Kawawa's statement was confirmation of Communist China's influence in Tanzania. The PRC and Tanzania signed an agreement on economic and technical cooperation, as well as a joint communiqué two days later.<sup>31</sup>

Prior to Kawawa's visit, the PRC was active in maintaining and furthering influence on Zanzibar. At the beginning of June, it was reported that the PRC had agreed to grant a long-term interest-free loan of \$14 million to Zanzibar.<sup>32</sup> Notably, this economic aid package was directed to Zanzibar only and not to the United Republic.<sup>33</sup> Although the PRC was engaged with the Tanzanian government, it

was clearly maintaining separate and distinct relations with Zanzibar. Also in June 1964, a PRC economic and goodwill mission spent nine days in Tanzania.<sup>34</sup> The two countries eventually signed an economic and technical cooperation agreement. According to analysts, however, more “significant developments” were likely to have occurred behind the scenes. Delegations of Communist Chinese women and youth reportedly visited Zanzibar as well, and PRC technicians were working on the first twenty-five tractors to arrive as gifts from Peking.<sup>35</sup> From the very beginning, Communist China approached Tanzania with multiple instruments of grand strategy. SA was soon to come.

In August 1964, a Communist Chinese military mission was invited to teach the use of PRC weapons.<sup>36</sup> The military mission consisted of seven instructors and four interpreters, arriving sometime before September 9.<sup>37</sup> President Nyerere made reference to the PRC instructors at a news conference and noted that the training period would not exceed six months. President Nyerere scoffed at suggestions that the PRC would “transform Tanganyika to a colony.”<sup>38</sup> On the island, it was further reported that the PRC was already training about 300 Zanzibaris, as part of multinational training of two Zanzibar army battalions (along with Soviets and East Germans). In addition, the PRC had sent twenty-one instructors to train the Tanzanian Police Force.<sup>39</sup> “Thus, in 1964, Tanzania became the first African country to have an official Chinese military mission to train its army, as distinguished from the clandestine training of guerrilla forces [in Ghana and other parts of sub-Saharan Africa].”<sup>40</sup> Quite simply, “This meant increased Chinese influence in the [national liberation] movements as well as increased adoption of Chinese tactics of guerrilla warfare.”<sup>41</sup> From the onset, PRC SA was multifaceted. It included weapons training, battalion level training, and training of security forces.

While training occurred in the southern region of Tanzania, guerrillas were also reportedly supplied with PRC arms and weapons—free of charge.<sup>42</sup> Testimony from an imprisoned black African confirmed these reports. Sometime in late 1963, according to this testimony, an African named Peter Metshane was selected and sent for military training in the PRC.<sup>43</sup> Metshane went to Bechuanaland (modern-day Botswana) and from there flew to Tanganyika, India, Burma, and, eventually, Communist China. He was enrolled in the military academy at Nanking and was trained in the use of anti-tank mines and other equipment.<sup>44</sup> Not only was Tanzania becoming a base of PRC operations, it was also a transit point to Communist China. Therefore, the PRC approach to SA consisted of training in Tanzania as well as Communist China.

Covert forms of PRC SA occurred later in the year. In October 1964 the Portuguese reported that five groups of guerrillas had penetrated Portugal’s East African

territory of Mozambique from Tanganyika. In operations against the guerrillas, the Portuguese captured guerrilla general Lucas Fernandes, who “was said to have received his military training in Peking.”<sup>45</sup> According to additional Portuguese reports, the Soviet Union and Communist China were aiding Cubans, Algerians, and Tanzanians to subvert Portuguese Africa. Arms and munitions were reportedly landing in Tanzania as well.<sup>46</sup> Furthermore, in another covert form of PRC SA at the end of 1964, Ali Mahfoudh, an Arab who was one of Babu’s principal pro-PRC lieutenants, headed to Mtwara on the mainland with men and equipment to assist one of the guerrilla movements in Mozambique, the Front for the Liberation of Mozambique (FRELIMO).<sup>47</sup> The PRC had converted Tanzania into a base of guerrilla warfare operations, again demonstrating the multifaceted level of SA.

In January 1965, the Central Intelligence Agency (CIA) reported that Communist Chinese trucks were being used to transport weapons to the Congo and the Mozambique border.<sup>48</sup> In addition, it was reported that twenty-seven Chinese military advisers were on the mainland and Zanzibar. The advisers were originally sent to train Tanzanian troops, but it was believed that some were training rebel forces.<sup>49</sup> Notably, PRC advisers were used for multiple purposes—to train regular and irregular forces, both formally and informally. The PRC also used SA to sustain Tanzania’s political leadership. According to Alaba Ogunsanwo, a scholar on PRC-Africa relations at the time, “The [Communist] Chinese first helped to train a field force unit which was meant to deter the army from staging [another] coup.”<sup>50</sup> On 8 February 1965, battalion-level troops completed training in the use of PRC arms. Troops then took part in a military parade on Monduli Plains near Arusha in Northern Tanzania. On display included PRC-made tank guns, heavy machine guns, mortars, and automatic rifles.<sup>51</sup> Toward the middle of the year, in May 1965, twenty-seven Communist Chinese military advisers were still reported to be in Tanzania, including those on Zanzibar.<sup>52</sup> After training the PRC-equipped Tanzanian People’s Defence Force (TPDF) battalion, the PRC advisers reportedly gave a light weapons course to a 600-man reserve group from the Mozambique border area. It was also reported that PRC advisers had trained similar groups that had become a part of the 10,000-man Volunteer Reserve Force, and that they would also train the Tanzanian police force, prison services, and National Youth Service.<sup>53</sup> Thus, PRC advisers trained a multitude of government military and security forces—demonstrating active SA to Tanzania.

Between September 1964 and June 1965, it was reported that the PRC had delivered 1,025 tons of arms and ammunition to Dar es Salaam, and as many as three hundred Communist Chinese technicians were on the mainland.<sup>54</sup> In May 1965, a shipment of PRC arms was intercepted in Kenya after it had crossed the border from Tanzania. Uganda later claimed the weapons were for its army, and the

Kenyans eventually released them.<sup>55</sup> While on Zanzibar for the first time, Premier Chou visited the PRC training camp at Mtoni and spoke at a reception hosted by Vice President Karume, saying Zanzibar was “the nucleus of Tanzania.”<sup>56</sup> Before departing, on 8 June Premier Chou and President Nyerere signed a joint communiqué, in which the PRC expressed “hearty joy” over the fact that Tanzania was “playing an increasingly important role in supporting the national-liberation movement in Africa.”<sup>57</sup> Chou’s trip resulted in public praised for one another. And, the PRC played a valuable role in assisting Tanzania. With overt PRC political support, training and advising Tanzanian forces preceded the transfer of PRC weapons and equipment. By spring 1966, President Felix Houphouet-Boigny of the Ivory Coast warned of the danger of Communist China in the region stating, “The door is already open to the [Communist] Chinese in East Africa.”<sup>58</sup> The Ivory Coast president was correct. By this time, it was estimated by Western sources that the PRC had shipped approximately 11,000 tons of arms to Tanzania.<sup>59</sup> Communist China, again according to Western sources, had approximately 250 to 300 technicians, trainers, and other personnel in Tanzania.<sup>60</sup>

Yet Communist China continued to look for different channels to conduct SA. On 25 April 1966, Chairman Liu and Premier Chou sent a joint message to President Nyerere congratulating him on Tanzania’s National Day. The following day in Peking, Tanzanian Ambassador Waziri Juna hosted a reception to celebrate the occasion. Among the guests were Vice Premiers Chen Yi and Tan Chen-li, Vice-Chairman of the Standing Committee of the NPC Lin Peng, and other leading members of government departments, the People’s Liberation Army (PLA), and PRC people’s organizations.<sup>61</sup> The diverse PRC representation signified the all-around nature of PRC relations with Tanzania, as well as the various means through which the PRC conducted operations. These high level political dialogues facilitated PRC SA.

In the middle of 1966, Communist China and Tanzania signed an agreement to establish a joint shipping company. The company’s initial capitalization, it was reported, would be the equivalent of \$4.2 million and the line would operate two 10,000-ton vessels. “According to Tanzanian Government sources, the initial capital will be supplied entirely by China. Half of the initial capital will be an interest-free loan repayable from Tanzania’s share of profits over the 10-year period from 1977.”<sup>62</sup> The favorable conditions for Tanzania were an effective ploy. Ogunsanwo wrote astutely: “It should also be pointed out that a joint shipping company would reduce the adverse publicity abroad accompanying any Chinese delivery of goods and weapons to Tanzania, something which was not always possible in the past.”<sup>63</sup> The PRC had arranged for the creation of a strategic line of communication across

the Indian Ocean. Also, the PRC looked to codify its trans-Indian Ocean ties in order to benefit its SA operations in Tanzania.

The PRC took full advantage of its growingly intimate relations with Tanzania. A Tanzanian “goodwill” military delegation visited the PRC in August 1966 and reached an understanding about future Communist Chinese construction of a Navy and an Air Force for Tanzania.<sup>64</sup> In addition, it was reported that naval officers were sent covertly to the PRC for training. At the end of September 1966, a seven-man goodwill mission from the mainland political party Tanganyika African National Union (TANU) embarked on a two-week visit of Communist China.<sup>65</sup> The next month, Tanzanian commissioner of police Hamza Aziz also went on a study tour that included Communist China. Notably, personnel from the PRC Embassy in Dar es Salaam saw Aziz off at the airport.<sup>66</sup> Thus, PRC-Tanzanian political relations supported active PRC SA, which was conducted within Tanzania as well as in Communist China.

As an illustration of the close political and military ties between the two countries, President Nyerere visited Communist China for a second time in June 1968.<sup>67</sup> Among PRC guests welcoming him in Peking were Premier Chou, Vice Premiers Chen Yi and Li Hsien-nien, and Chief of the General Staff of the PLA Huang Yang-sheng.<sup>68</sup> While visiting the PRC, President Nyerere secured \$280,000 for agricultural projects, including irrigated farms, small-scale hydroelectric plants, and flood control measures.<sup>69</sup> The PRC, while focused on the Tanzania-Zambia (Tan-Zam) railway, was also interested in sustaining diverse relations with Tanzania.<sup>70</sup> Once again, high level political visits included military representation.

While strengthening relations with Tanzania as a whole, PRC continued to provide assistance to and conduct operations in Zanzibar. Within the framework of technical assistance to Zanzibar, for example, the PRC supplied twenty-five doctors and medical assistants, six technicians and instructors for a government printing facility and broadcasting station, as well as mechanics and engineers—all totaling approximately four hundred personnel on the island.<sup>71</sup> The PRC also operated a training camp outside of the town of Zanzibar, with seventeen advisers teaching small arms and guerrilla warfare. In addition, the Communist Chinese had “taken over the former US Project Mercury tracking station at Tungu, where they [were] training 800 new Zanzibari recruits.”<sup>72</sup> As previously mentioned, in September 1960, reports indicated that PRC influence in Zanzibar forced the United States to change its plans to establish a satellite tracking station there.<sup>73</sup> To further its interests, the PRC denied the United States a strategic outpost (satellite tracking station in the Indian Ocean) and used the same facility for Communist Chinese objectives (to train Zanzibaris).

Because so much attention had been paid to PRC-Tanzanian relations, the Tan-Zam railway in particular, there was public suspicion regarding both countries' intentions. In a rare interview granted in November 1969, President Nyerere added to the suspicion by sidestepping questions regarding Tanzanian acquisition of PRC fighter jets.<sup>74</sup> But he did acknowledge that Tanzania had actively supported guerrilla movements against white minority governments in southern Africa "for years" without either an air force or navy.<sup>75</sup> Nyerere's statements demonstrated PRC doctrinal influence in guerrilla warfare. In December 1969, the PRC-assisted military barracks in Nachingwea were handed over to the Tanzania government. In addition, PRC military experts took over training of the Tanzanian armed forces the next month.<sup>76</sup> At about this time, it was reported that the PRC had 150 military instructors and twenty-two police instructors in Tanzania, and "Chinese military instructors [were] playing the role of political agents of Peking within the Tanzanian Army."<sup>77</sup> After 1970, "the PRC was the only country providing military equipment and training to the Tanzanian forces."<sup>78</sup> PRC SA to Tanzania was both overt and covert SA, with instructors and advisers throughout the Tanzanian and Zanzibari military and security establishments.

PRC operations in Tanzania continued throughout 1970. For example, the PRC began construction of a naval base in May. The next month, a PRC-aided farm implements factory opened in Ubungu, near Dar es Salaam.<sup>79</sup> By July, a PRC-built hospital in Mokoani on Pemba was operational and a vaccine plant at Mabibo near Dar es Salaam was completed.<sup>80</sup> The PRC effectively combined military and development aid. Face-to-face communications between the two countries continued as well. At the invitation of the PRC Ministry of National Defence, Colonel Ali Mahfudh, Chief of Operations and Training of the TPDF, led a Tanzanian military delegation to Communist China, from 28 September to 29 October 1970.<sup>81</sup> On 8 October, the Tanzanian military delegation departed Peking to visit Yenan, Sian, Shaoshun, Changsha, Kwangchow, Shanghai, and Nanking. This was the first well-publicized military-to-military relations visit, signifying a comfort level and close cooperation between the two countries.

By the end of the year, it was clear that Communist China was firmly committed to strengthening relations with Tanzania. On 5 November 1970, Vice Chairman of the PRC Tung Pi-wu and Premier Chou sent a message of congratulations to President Nyerere after his reelection. The message read in part: "May the friendly relations and co-operation between our two countries constantly develop and grow in strength."<sup>82</sup> PRC operations continued on the island as well. By the end of 1970, the PRC had reportedly given Zanzibar a series of loans worth \$12 million. "The schemes involved a large number of Chinese instructors and officials."<sup>83</sup> According to various reports, the number of PRC personnel in Zanzibar ranged from



100 to 400.<sup>84</sup> Thus, the PRC was operating successfully on the mainland and the island.<sup>85</sup>

The PRC had become permanently ensconced in Tanzania. “By June [1971], there will be 13,000 Chinese working on the 1,100-mile railroad, which is to link the Zambian copper mines to the Indian Ocean, bypassing white-ruled Rhodesia and Mozambique.”<sup>86</sup> The same report noted that other Communist Chinese in Tanzania were “advising the army, planning a naval base and building a plant outside Dar es Salaam for the manufacture of smallpox vaccine.”<sup>87</sup> Communist China combined SA to Tanzania with various development projects throughout the country, providing the PRC with influence across a wide spectrum of Tanzanian society.

PRC SA to Tanzania continued to be active, supported by high-level political relations. In December 1971, the PRC-built naval base was completed and handed over to the Tanzanian government.<sup>88</sup> As an example of growing military ties, between 1964 and 1972, Tanzania “received perhaps \$40 million of [Communist] Chinese military and commitments. The equipment delivered include[d] MiG jet fighters, light tanks, patrol boats, and various ground forces and support equipment. The [Communist] Chinese [were] also constructing naval and air facilities in Tanzania.”<sup>89</sup> From 20 to 25 August 1972, a Tanzanian goodwill delegation visited the PRC. Minister of Foreign Affairs John S. Malecela led the delegation, and Lieutenant Colonel Hafidh Suleiman, member of the Zanzibar Revolutionary Council, was the deputy.<sup>90</sup> While in Peking, the Tanzanian delegation met with Premier Chou, Foreign Minister Chi Peng-fei, Minister of Economic Relations with Foreign Countries Fung Yi, Deputy Chief of the General Staff of the PLA Peng Shao-hui, and Vice Foreign Minister Ho Ying.<sup>91</sup> Once more, the inclusion of a PLA official was an indication of the strong military and political relations between Communist China and Tanzania.

The next year a Tanzanian official was assassinated. Lieutenant Hamoud, “recently returned from training in Eastern Europe,” murdered Vice President Karume on 7 April 1972.<sup>92</sup> Although never fully explained, Hamoud’s action may have been a simple personal vendetta.<sup>93</sup> Nevertheless, the PRC was suspected due to its history of operations in Zanzibar. Babu was allegedly involved in the assassination of Karume, however President Nyerere refused Zanzibar’s request to extradite him and held him in prison until 1978.<sup>94</sup> Three days after the assassination, Acting Chairman Tung Pi-wu sent a message to President Nyerere expressing condolence for the death of Vice President Karume. The following day, Premier Chou, Vice Chairman Yeh Chien-ying, Vice Premier Li Hsien-nien, and Foreign Minister Chi Peng-fei called at the Tanzanian embassy in Peking to express condolences.<sup>95</sup> In

spite of the assassination, three Tanzanian delegations visited the PRC a month later.<sup>96</sup> They included a military delegation led by Junior Minister of Defence and National Service Geoffrey Oscar Mhagama, a Home Affairs delegation led by Home Minister Saidi Ali Maswaya, and an Education delegation of the University of Dar es Salaam. Between 5 and 20 May 1972 the Tanzanian military delegation visited the PRC, but no details were made public.<sup>97</sup> At a farewell banquet on 19 May, Junior Minister Mhagama said that under the leadership of Chairman Mao and President Nyerere the two countries and their armies had established friendship on a solid basis.<sup>98</sup> Despite Karume's assassination, therefore, PRC-Tanzanian political and military relations—including SA—continued to flourish.<sup>99</sup>

By 1972 it was reported that Tanzania was “undoubtedly Peking's most important base in Africa and one of that country's best friends.”<sup>100</sup> This was particularly true with regards to PRC SA to Tanzania. As an example: “[Communist] Chinese merchant ships generally call[ed] at Dar es Salaam every 10 days and discharge[d] military supplies, construction equipment for [Tan-Zam] and general cargo—always under conditions of secrecy.”<sup>101</sup> In addition, PRC technicians were building an airfield for the Tanzanian Air Force as well as advising and training Tanzanian personnel.<sup>102</sup> The PRC also used Tanzania as a training base for African liberation movements. According to a report from Africa, PRC instructors were “prominent in the training of terrorists in camps in Dar es Salaam, Bagomoya, Moshi, Mguni, Songea, Kongwa, Morogoro and Nachingwea.”<sup>103</sup> It was also reported that PRC instructors studied operational problems and acted as advisers to guerrillas and the Liberation Committee of the OAU.<sup>104</sup> Thus, Communist China was heavily involved in all dimensions of SA to Tanzania.

Communist China's strategic line of communication with Tanzania was well established by this time. On 18 November 1972 *Chamwino*, Chinese-Tanzanian Joint Shipping Company's 10,000-ton-class ocean-going vessel, was commissioned as the company's third ocean-going ship.<sup>105</sup> The two others were the *Africa-Asia* and *Co-operation*. The time it took to develop this strategic communication line—1966 to 1972—indicated Communist China's strategic and operational mindset: patient and long term.<sup>106</sup> The strategic nature of PRC-Tanzanian relations continued the next year. On 28 January 1973 Vice Minister of National Defence Wang Shu-sheng hosted a banquet for the visiting Tanzanian military delegation led by E. M. Sokoine, Minister of Defence and National Service.<sup>107</sup> Speaking at the banquet, Vice Minister Wang said the people of Communist China and Tanzania had always united with and supported one another and were comrades-in-arms on the same front.<sup>108</sup> Their political unity and militancy went hand in hand.<sup>109</sup> Identifying common interests, the PRC successfully cultivated SA to Tanzania.

By this time, PRC SA to Tanzania was robust. Between 1971 and 1975, the PRC delivered \$47 million in military aid to Tanzania.<sup>110</sup> Meanwhile, the PRC continued to conduct guerrilla warfare training for liberation movements in the country.<sup>111</sup> It was also reported that graduates were supplied with arms and ammunition to conduct operations in such countries as South Africa, Mozambique, and Angola. According to the US Department of State, Rhodesia, in particular, had Communist Chinese-trained guerrillas operating from bases in Zambia and Mozambique.<sup>112</sup> In May 1974, however, Tanzania denied reports that it had offered the PRC base construction rights and naval positioning rights along the Tanzanian coast.<sup>113</sup> The next year, 700 Communist Chinese military technicians were reported to be in Tanzania, along with 4,100 economic technicians.<sup>114</sup> Between October 1975 and September 1976, moreover, the PRC financed the construction of a military academy at Munduli in Arusha, providing Tanzania with an indigenous capability to train its military officers.<sup>115</sup> Furthermore, between 1955 and 1976 over 1000 Tanzanian military personnel reportedly trained in the PRC.<sup>116</sup> PRC SA to Tanzania was multi-faceted and multi-dimensional—from training and arming to equipping and building—all in support of PRC political objectives.

PRC SA to Tanzania was deliberate and coordinated. On Zanzibar and the mainland, Communist China identified and cultivated groups with common interests. Although Tanzania may have been considered a “socialist-leaning” state in Africa, the PRC adjusted its operations to the political environment successfully to maintain contact and further influence the country and the region.<sup>117</sup> “In Tanzania, as in Ghana, the initial opposition of some government officials had first to be overcome.”<sup>118</sup> Eventually, the PRC was able to provide overt and covert SA at all levels. Remarkably, in 1972 “Tanzania [was] the only non-Communist country that [was] almost completely dependent on China for arms and training.”<sup>119</sup> PRC domination of SA demonstrated an accurate assessment of the political conditions in Tanzania. Building on the mainland’s historic anti-colonial mentality, the PRC helped train, arm, and equip the Tanzanian military and security forces as well as the various national liberation movements based in Tanzania.

Throughout its operations, the PRC used public communications—in print and in person—to further political and military objectives. “When addressing East Africa, the Peking propagandists put forward an additional case for ever-closer understanding. They pointed to the historical links across the Indian Ocean.”<sup>120</sup> Thus, the PRC was successful in creating Tanzania into a “beachhead in Africa.”<sup>121</sup> Moreover, with specific reference to the Tan-Zam railway, Ogunsanwo observed: “The railway when completed, together with its infrastructure, would provide an excellent communication system for Chinese military ‘aggression.’”<sup>122</sup> Therefore, as another analyst of the Tan-Zam railway explained, “China’s interest in the Tan-

Zam project [was] manifestly not economic or commercial. It [was] strategic.”<sup>123</sup> Thus, PRC grand strategy dictated operations in Tanzania.

With PRC SA, Tanzania was converted into a close ally sympathetic to Communist China’s global ambitions. “[Communist] Chinese propaganda and military aid to the national liberation movements in Mozambique, Angola and Portuguese Guinea continued and arms were delivered through . . . Tanzania.”<sup>124</sup> Simply, “Tanzania’s geographical position invited [Communist] Chinese interest. The country is contiguous to the Congo, Zambia and Mozambique. [Communist] Chinese arms went through Tanzania to the Congo rebels. The country [was] thus a gateway to three key nations in the struggle to free the southern third of Africa from white domination.”<sup>125</sup> For Communist China, geography revealed Tanzania’s strategic importance: Tanzania bordered eight African nations and was on the western shore of the Indian Ocean, the most accessible sea route from East Asia.<sup>126</sup> The PRC established a permanent foothold in Tanzania—first on Zanzibar, then on the mainland.

The manner in which Communist China conducted SA to Tanzania merits the concluding word. How the PRC provided SA was just as important as what it provided. SA was part of a larger, organized Communist Chinese grand strategy. PRC SA to Tanzania was characterized by patience, coordination, and calculation. Step-by-step, the PRC took time to understand the local conditions of Tanzania—its geography, people, and culture. Doing so allowed the PRC to take advantage of political and security situations in Tanzania. Frequently, the PRC hosted visiting Tanzanian delegations to shape and influence decisions relevant to PRC SA. Finally, it is critically important to understand PRC SA to Tanzania as part of its grand strategy (or, as JP 1-02 states, SA “in furtherance of national policies and objectives”). Providing SA to Tanzania, the PRC continually recognized the relationship between the political and military instruments of grand strategy—with political objectives taking precedent over military ones.

## Endnotes

1 The author wishes to thank Colin Gray, Tom Kane, David Lonsdale, Tony Pennay, and Jon Snook for their comments and recommendations on different versions of this paper. Any errors or misrepresentations are the author's alone.

2 PRC and Communist China will be used interchangeably throughout this paper.

3 Prior to its union on 26 April 1964, Tanzania was comprised of mainland Tanganyika and island Zanzibar (which included Zanzibar and Pemba islands).

4 In this paper, grand strategy is defined as the calculated and coordinated use of all the resources of a state or non-state actor to preserve and enhance long-term interests. Definition derived from the following: B. H. Liddell Hart, *Strategy: The Indirect Approach* (London: Faber and Faber Limited, 1967); Edward Mead Earle, ed., *Makers of Modern Strategy* (Princeton, NJ: Princeton University Press, 1943); and Paul Kennedy, "Grand Strategy in War and Peace: Toward a Broader Definition," in *Grand Strategies in War and Peace*, ed. Paul Kennedy (New Haven, CT: Yale University Press, 1991).

5 The following Department of Defense definition of SA will help guide this paper's examination of PRC SA: "Group of programs authorized by the Foreign Assistance Act of 1961, as amended, and the Arms Export Control Act of 1976, as amended, or other related statutes by which the United States provides *defense articles, military training, and other defense-related services by grant, loan, credit, or cash sales* in furtherance of national policies and objectives." Joint Publication 1-02, "DOD Dictionary of Military and Associated Terms," as amended through 31 August 2005. [Emphasis added]

6 For the purposes of this paper, Communist China's grand strategic objectives from 1949 (and, arguably, to the present) may be identified as PRC security, Chinese Communist Party authority, international unity (under PRC leadership), and economic and scientific development. These objectives all contribute to Communist China's paramount objective of becoming a global power. For a more detailed explanation, see Donovan C. Chau, "Grand Strategy Into Africa: Communist China's Use of Political Warfare, 1955-1976," unpublished Ph.D. dissertation, University of Reading, United Kingdom, 2005, especially Chapter 2.

7 Clayton described the revolution as one that re-stratified the economic structures and social systems as well as changed the ethnic composition of Zanzibar. Anthony Clayton, *The Zanzibar Revolution and Its Aftermath*, Hamden, CT: Archon Books, 1981, p. xvi.

8 Ali A. Mazrui, "Thoughts on Assassination in Africa," *Political Science Quarterly*, Vol. 83, No. 1, March 1968, p. 41.

9 "African Unrest," *New York Times*, January 26, 1964, p. E1.

10 "They had to be replaced." Based on an anonymous source. Alaba Ogunsanwo, *China's Policy in Africa, 1958-71*, London: Cambridge University Press, 1974, p. 138.

11 "Ho's stint in East Africa," moreover, "[had] been characterized by considerable mobility, a necessary quality in the fluid state of East African politics." Donald W. Klein, "Peking's Diplomats in Africa," *Current Scene*, Vol. II, No. 36, July 1, 1964, p. 6.

12 "Round the World: East Africa: Operation Return," *Peking Review*, Vol. VII, No. 6, February 7, 1964, pp. 33-34.

13 Central Intelligence Agency, *A Reassessment of Julius Nyerere*, Special Memorandum No. 17-65, June 10, 1965, p. 4. Memorandum found in *CIA Research Reports Africa, 1946-1976*, Frederick, MD: University Publications of America, 1982.

14 The ZNP was the predominantly Arab political party on the island.

15 Cited from Zanzibar Radio, 4 and 19 February 1964 in Clayton, 135; Ogunsanwo, 136. Babu made the announcement of PRC aid over Zanzibar radio. Robert Conley, "US Fails to Stop Zanzibar's Diplomatic Break," *New York Times*, February 21, 1964, p. 5; "Zanzibar Expels Top British Aide," *Washington Post Times Herald*, February 21, 1964, p. A30.

16 Clayton, 108.

17 Peter Braestrup, "Algerians Decry Criticism By US," *New York Times*, April 3, 1964, p. 6. Other countries listed included Mali, Ghana, Angola, and Algeria.

18 He was later recalled on 30 July after the Union of Tanganyika and Zanzibar. "Shuffles Mark Year in Peking Diplomacy," *Washington Post Times Herald*, January 9, 1965, p. A7.

19 "Soviet Arms Cargo in Zanzibar Denied," *New York Times*, April 6, 1964, p. 6.

20 Clayton, 107. Clayton did not believe the station had any military application, but does not provide any documentary evidence except for stating that Babu "misrepresented" the station as a "rocket base."

21 "Round the World: Zanzibar Demands Removal of US Bases," *Peking Review*, Vol. VII, No. 16, April 17, 1964, p. 20.

22 See below for how Communist China eventually used this base.

23 Klein referred to the PRC ship moored off the coast as the *S.S. Peace*. Klein, p. 7, endnote 12.

24 "China Said to Seek Base in Zanzibar for Subversion," *New York Times*, May 28, 1964, p. 18. The possibility that Communist China wanted to maintain a firm presence on the island after the Union could not be discounted, particularly because the union was characterized as "hastily arranged." Central Intelligence Agency, *The Current Disarray in Zanzibar*, Intelligence Memorandum, December 2, 1968, p. 3.

25 It was reported to be a "10-man goodwill mission." "Tanganyikans to Visit Peking," *New York Times*, June 8, 1964, p. 32. Wei reported an interest-free loan of \$28 million. Wei Liang-Tsai, *Peking Versus Taipei in Africa 1960-1978*, Taipei: Asia and World Institute, 1982, p. 206.

26 Cited from Sunday Times, June 21, 1964 in Ogunsanwo, p. 137. Wei also reported a gift of \$2.8 million. Wei Liang-Tsai, p. 206. Loan and grant amounts converted from pound sterling.

27 Director of Central Intelligence, *Tanzania Taking the Left Turn*, Special Report, May 21, 1965, p. 5. As of May 1964, Babu was reported to be minister for commerce and co-operatives. But at the time, it was reported that Babu was one of three Ministers of State in the Directorate of Development and Planning. Sydney Gruson, "Tanganyika-Zanzibar Union Is Reported Shaky," *New York Times*, June 3, 1964, p. 9.

28 In addition to economic considerations, Babu was reportedly engaged in other meetings while in Peking. "Intelligence reports said he had concentrated on meetings with Chinese military leaders, notably with Marshal Ho Lung, a guerrilla warfare expert." Tad Szulc, "Zanzibar Chiefs Tighten Red Ties," *New York Times*, June 21, 1964, p. 13. Szulc,

of course, does not disclose “intelligence reports.” Later in the same year, the CIA finally concluded Babu was a Communist. “He probably is a Communist—in any case his actions consistently serve the Communist interest.” Central Intelligence Agency, *Implications of Growing Communist Influence in URTZ*, p. 6.

29 Clayton, p. 115.

30 “Tanganyika-Zanzibar Guests Visit China,” *Peking Review*, Vol. VII, No. 25, June 19, 1964, p. 6.

31 For the text, see “Joint Communique of China and Tanganyika-Zanzibar,” *Peking Review*, Vol. VII, No. 25, June 19, 1964, pp. 12-13.

32 Central Intelligence Agency, *The Current Disarray in Zanzibar*, p. 5. The loan was reportedly announced prior to Kawawa’s visit. “Zanzibar Promised Big Loan By Peking,” *New York Times*, June 9, 1964, p. 16.

33 Point made in Peter Vanderwicken, “Red Threat to Africa Is Eased by Zanzibar’s Link With Tanganyika,” *Wall Street Journal*, July 13, 1964, p. 1.

34 As the mission left Tanzania, the PRC issued a statement hailing the “excellent revolutionary situation” prevailing in Africa. “China Hails African Outlook,” *New York Times*, June 21, 1964, p. 13.

35 Robert Conley, “Stakes High in Zanzibar,” *New York Times*, June 28, 1964, p. E5. See February 1963 for more on agreement involving tractors.

36 Cited from Colin Legum, *Observer*, August 30, 1964, in Colin Legum, “Africa and China: Symbolism and Substance,” in A. M. Halpern, ed., *Policies Toward China: Views from Six Continents*, New York: Council on Foreign Relations, 1965, p. 425; Ogunsanwo, p. 138.

37 Wei Liang-Tsai, p. 207, footnote 68.

38 “Round the World: Tanzam Republic: President Nyerere Protests,” *Peking Review*, Vol. VII, No. 37, September 11, 1964, p. 30.

39 Wei Liang-Tsai, p. 207, footnote 68.

40 Central Intelligence Agency, *A Reassessment of Julius Nyerere*, p. 7; Wei Liang-Tsai, p. 207.

41 Ogunsanwo, p. 172.

42 Pointe Noire in Congo (Brazzaville) and Mtwara in Tanzania were reportedly entry points for PRC arms for liberation movements in Mozambique and Angola. *Ibid.*, p. 232.

43 “South African Jails 2 Men For Arms Training in China,” *New York Times*, September 8, 1965, p. 22.

44 Metchane and another black African were sentenced to ten years imprisonment in South Africa. Metchane also testified that “four other Africans” had enrolled at the same time in Nanking. *Ibid.*

45 “Lisbon Confirms Move By Africans,” *New York Times*, October 11, 1964, p. 15.

46 *Ibid.*

47 Clayton, pp. 112, 119.

48 Central Intelligence Agency, *Chinese Communist Activities in Africa*, Memorandum, April 30, 1965, p. 9. Memorandum in *CIA Research Reports Africa, 1946-1976*, Frederick, MD: University Publications of America, 1982.

49 *Ibid.*

50 Ogunsanwo, p. 139.

- 51 Cited from *Dar es Salaam Radio*, February 8, 1965, and *The Times*, September 2, 1964, in *Ibid*.
- 52 Director of Central Intelligence, *Tanzania Taking the Left Turn*, p. 3.
- 53 *Ibid*.
- 54 On May 8, a shipment of 170 tons of PRC small arms and ammunition was unloaded in Dar es Salaam. Lawrence Fellows, "Nyerere Tempers Welcome To Chou," *New York Times*, June 5, 1965, p. 7.
- 55 Lawrence Fellows, "China Denounced By Kenya Official," *New York Times*, June 13, 1965, p. 21.
- 56 Lawrence Fellows, "Chou, in Zanzibar, Attacks US After Welcome by Large Crowd," *New York Times*, June 7, 1965, p. 2. In addition, Premier Chou stated the following about the Zanzibar Revolution: "That was a marvelous achievement. The Chinese people sincerely admire the indomitable revolutionary and militant spirit of the fraternal Zanzibar people." "Premier Chou Visits Tanzania," p. 6.
- 57 "China-Tanzania Joint Communique," *Peking Review*, Vol. VIII, No. 24, June 11, 1965, p. 7.
- 58 Drew Middleton, "Ivory Coast Head Calls China Peril," *New York Times*, April 10, 1966, p. 17. President Houphouet-Boigny made explicit warnings about long-term PRC objectives in Africa. According to President Houphouet-Boigny, the PRC aim was "to obtain either open or covert control of governments and their economies rather than wholesale conversion of the African masses to Communism"; "Africa, underpopulated Africa, is their long-term goal and we must be alive to the danger." Middleton, p. 17.
- 59 Russia reportedly had shipped the same amount of arms. Drew Middleton, "Tanzanian Denies Peking Influence," *New York Times*, March 17, 1966, p. 17.
- 60 For example, twenty-two instructors were at Tanzania's police training college.
- 61 "The Week: Tanzania's National Day," *Peking Review* Vol. 9, No. 18, April 29, 1966, p. 4.
- 62 "Tanzania and China to Start Ship Line," *New York Times*, July 8, 1966, p. 17.
- 63 Ogunsanwo, p. 199. Blake referred to the shipping line as "largely symbolic." Alex Blake, "Peking's African Adventures," *Current Scene*, Vol., V, No. 15, September 15, 1967, p. 6.
- 64 According to an anonymous source. Ogunsanwo, pp. 212-13.
- 65 "Tanganyikans to Visit Peking," *New York Times*, September 26, 1966, p. 3.
- 66 "Police Chief on Tour," *Washington Post Times Herald*, October 12, 1966, p. A6.
- 67 Nyerere first visited the PRC on an eight day visit in February 1965.
- 68 Notable among President Nyerere's delegation were Ahmed Mahmud, member of the Zanzibar Revolutionary Council; Juma Almasi, National Executive Committee member of the Afro-Shirazi Party; Brigadier General Sarakikya of the Tanzanian People's Defence Forces; M.N.E. Shaidi, Inspector General of the Police; and Michael Indadha and J. Marusi, representatives of TANU. "President Nyerere Arrives in Peking," *Peking Review*, Vol. 11, No. 25, June 21, 1968, pp. 3-4.
- 69 Thirteen Tanzanian delegations visited the PRC in 1966, eight in 1967, and three in 1968. Ogunsanwo, p. 204. President Nyerere was schedule to be in the PRC from 18 to 21 June. "Tanzanian to Visit Red China," *New York Times*, June 3, 1968, p. 11. On 22 June, President Nyerere's delegation reportedly left Peking for the North Korea. "Presi-



dent Nyerere's Visit to China," *Peking Review*, Vol. 11, No. 26, June 28, 1968, p. 5.

70 Although a large and symbolic undertaking between Communist China and Tanzania, the Tan-Zam railway will not be discussed at length because of this paper's focus on PRC SA to Tanzania. Its mention will be in the context of PRC SA.

71 Central Intelligence Agency, *The Current Disarray in Zanzibar*, p. 6. The CIA also noted the following with some trepidation: "The Chinese have gradually become the dominant force [in terms of economic aid] because of their well-managed, relatively-inexpensive aid, their ability to live frugally and work hard, and their extensive and well-financed contacts—both overt and covert—with many influential Zanzibaris."

72 *Ibid.*, p. 7. The civilian side of the project was known as "Project Courier."

73 See above. Leonard Ingalls, "Peiping Presses Gains in Africa; Foothold Is Sought in Zanzibar," *New York Times*, September 4, 1960, p. 2.

74 In July 1968, Vice President Kawawa said Tanzania would develop her own navy and air force. "Tanzanian Defense Chinese Rail Aid," *New York Times*, November 23, 1969, p. 23.

75 C. C. Miniclier, "Dealings With Peking Defended by Nyerere," *Washington Post Times Herald*, November 19, 1969, p. A24.

76 It was reported that a new PRC built stadium in Zanzibar was completed in early January as well. Wei Liang-Tsai, p. 213.

77 "Communist Chinese Propaganda and Africa," *Afrique Nouvelle (Dakar)*, November 6-12, 1969, p. 18.

78 From 1965 to 1969, Canadians had established and trained the Tanzanian armed forces. Eugene K. Keefe, "National Security," in Irving Kaplan, ed., *Tanzania: A Country Study*, Washington, DC: Foreign Area Studies, American University, p. 256.

79 "African Newsletter: Tanzania Develops Its Own Industry," p. 23; Wei Liang-Tsai, p. 213.

80 The vaccines were reportedly used against smallpox and tuberculosis. Wei Liang-Tsai, pp. 213-214.

81 "The Week: Tanzanian Military Delegation Visits China," *Peking Review*, Vol. 13, No. 45, November 6, 1970, p. 29.

82 "The Week: Vice-Chairman Tung and Premier Chou Congratulate President Nyerere of Tanzania on His Re-election," *Peking Review*, Vol. 13, No. 46, November 13, 1970, p. 4.

83 Cited from the *Africa Record*, December 1970 in Clayton, p. 149.

84 *Ibid.*, p. 149, footnote 76. Howe reported the figure to be between 400 and 500 Communist Chinese in Zanzibar. Marvine Howe, "Zanzibar, Though Heavily Dependent on Chinese Communist Aid, Maintains Independent Policies," *New York Times*, September 23, 1970, p. 10.

85 From 1954 to 1970, Tanzania was the leading recipient of PRC economic credits and grants, totaling \$252 million. However, \$201 million was extended in 1970 alone, presumably for the Tanzam railway. Central Intelligence Agency, *Unclassified Table on Communist Economic Credits and Grants Extended to Less Developed Countries of the Free World, 1954-1970 and Years 1969 and 1970*, Memorandum for the Department of State, March 4, 1971, p. 1.

86 William Borders, "China Quietly Renewing An Active Role in Africa," *New York Times*, April 9, 1971, p. 15. In 1971, the CIA estimated 14,700 Communist Chinese economic technicians to be in Tanzania. Central Intelligence Agency, *Communist Economic Aid Extensions and Technical Assistance to Selected African Countries*, Memorandum for the Defense Intelligence Agency, January 20, 1972, p. 2.

87 Borders, p. 15.

88 Wei Liang-Tsai, p. 214.

89 Leo Tansky, "China's Foreign Aid: The Record," *Current Scene*, Vol. X, No. 9, September 1972, p. 9.

90 "The Week: Tanzania Goodwill Delegation In Peking," *Peking Review*, Vol. 15, No. 35, September 1, 1972, pp. 4, 22.

91 The delegation also visited Shihchiachuang and Shanghai. *Ibid.*, p. 22.

92 Clayton, p. 152.

93 He was the son of Mohamed Hamoud Barwani who had been the 1955 murderer of Ali Sultan Mugheiry, an Arab Association executive committee member on the Legislative Council who did not boycott against the British. The elder Hamoud was apparently killed in prison during the Revolution.

94 Wei Liang-Tsai, p. 205, footnote 63.

95 "The Week: Condolence on Karume's Death," *Peking Review*, Vol. 15, No. 15, April 14, 1972, p. 3.

96 "The Week: Guests from Tanzania," *Peking Review*, Vol. 15, No. 22, June 2, 1972, p. 3.

97 Wei cites *Chin-chi tao-pao*. Wei Liang-Tsai, p. 214. The military and home delegations stayed for 15 days.

98 "The Week: Guests from Tanzania," p. 4.

99 In all likelihood, the PRC was not involved in Karume's assassination.

100 "Red Onslaught on Southern Africa," *Bulletin of the Africa Institute of South Africa*, Vol. X, No. 9, October 1972, p. 358.

101 *Ibid.*

102 The airfield was in the vicinity of Ngerengere, west of Dar es Salaam.

103 "Red Onslaught on Southern Africa," p. 359. It was noted that political indoctrination was an important part of Communist Chinese curriculum.

104 *Ibid.*

105 "Friendship Log: Friendly Co-operation," *Peking Review*, Vol. 15, No. 50, December 15, 1972, p. 21. Chamwino was the Swahili name of a village in Dodoma region of central Tanzania.

106 On the financial front, in December 1972, a PRC bank delegation returned from a visit to Albania, Romania, France, Algeria, Tanzania, Zambia, and Pakistan. "The Week: News Briefs," *Peking Review*, Vol. 15, No. 52, December 29, 1972, p. 4. Chiao Pei-hsin, acting chairman of the Board of Directors and General Manager of the Bank of China, led the delegation.

107 "The Week: Tanzanian Visitors," *Peking Review*, Vol. 16, No. 5, February 2, 1973, pp. 5, 13.

108 *Ibid.*, p. 13.

109 “It [was] significant that one of [Communist] China’s leading strategists Lin Laing [was] in charge of indoctrination and motivation among terrorists in Dar es Salaam.” C. F. de Villiers, “China’s Decade in Africa,” *Bulletin of the Africa Institute of South Africa*, Vol. XI, No. 8, September 1973, p. 300.

110 Central Intelligence Agency, *Communist Economic and Military Aid to Africa*, Memorandum, February 18, 1976, p. 1.

111 Guinea was also reportedly a guerrilla training location.

112 Jack Anderson, “Secret Agent Diplomacy,” *Washington Post*, March 24, 1974, p. C7. The Soviet Union was also cited as a supporter of guerrilla movements.

113 Wei cited a BBC news source. Wei Liang-Tsai, p. 215.

114 As well as 10,000 economic technicians in Zambia. *Ibid.*, pp. 2, 5.

115 *Ibid.* The academy may also have been intended for political training.

116 1,025 to be precise. Colin Legum, ed., *Africa Contemporary Record: Annual Survey and Documents, 1977-78*, New York: African Publishing Company, 1979, p. C189.

117 Central Intelligence Agency, *The New Look in Chinese Communist Aid to Sub-Saharan Africa*, p. 1. Other states considered “socialist-leaning” in 1968 included Guinea, Mali, and Congo (Brazzaville).

118 Ogunsanwo, p. 261.

119 Tansky, p. 9.

120 Richard Hall and Hugh Peyman, *The Great Uhuru Railway: China’s Showpiece in Africa*, London: Victor Gollancz Limited, 1976, p. 47.

121 Director of Central Intelligence, *Communist China’s International Posture*, National Intelligence Estimate Number 13-7-70, November 12, 1970, p. 15.

122 Ogunsanwo, p. 209.

123 James C. Curran, *Communist China in Black Africa: The Tan-Zam Railway, 1965-1970*, Carlisle, PA: US Army War College, April 26, 1971, p. 43; Director of Central Intelligence, *Communist China’s International Posture*, p. 15. Curran’s work found in *Africa: Special Studies, 1962-1980*, Frederick, MD: University Publications of America, 1981.

124 Ogunsanwo, p. 239. Congo-Brazzaville was also cited as a PRC transit point.

125 Middleton, “Tanzanian Denies Peking Influence,” p. 17.

126 “Communist Chinese Propaganda and Africa,” p. 24.



## **Building the Malayan Army and Police—Britain’s Experience During the Malayan Emergency 1948–1960**

**Dr. James Corum—Command and General Staff College**

Counterinsurgency is a very manpower intensive form of warfare. This is a fact that the technologically-oriented West would like to ignore—but cannot. Although technology has a useful supporting role, effective counterinsurgency can only be accomplished by a wide degree of personal interaction and controlling the population threatened by the insurgency. Fighting insurgents hiding among the population, or conducting stability operations in an unstable environment, requires a large number of police and military personnel in order to establish the basic level of order and security necessary for normal civic life and economic development.

Few, if any, Western powers have enough military power to meet all the personnel requirements to assist a nation fighting insurgents, and also maintain an adequate force for conventional defense requirements. Even if enough military manpower were available for counterinsurgency operations it would be a poor long term strategy to depend on troops from an outside power to fight the insurgents. A primary requirement of counterinsurgency operations is establishing the legitimacy of the threatened government, and long-term dependence on outside forces undermines the legitimacy of the host nation government. Besides, fighting insurgents requires an intimate knowledge of the people, language, terrain and culture—and indigenous forces possess these attributes. Therefore, building and training effective indigenous security forces has been a central feature in almost every counterinsurgency campaign of the last century. The most successful counterinsurgency campaigns have featured well-trained and led indigenous forces in a lead role. The mission of building and training local security forces can rightly be considered a *sine qua non* for effective counterinsurgency doctrine and operations.

Despite the importance of indigenous force training in counterinsurgency, the literature on this subject is surprisingly thin. This is especially true in the training and employment of police forces in a counterinsurgency role, despite the fact that in many counterinsurgency campaigns the police have played a leading role.<sup>1</sup> For the professional Western soldiers, building, training and advising host nation armies and police forces has traditionally been seen as a far less important mission than direct combat operations. In any case, it is certainly less prestigious and less advantageous for a professional officer’s career.<sup>2</sup> Yet building and training indigenous forces ought to be seen as an important aspect of the military art and

not considered another temporary ad hoc mission. This paper is an attempt to shed some light upon a largely neglected part of modern military history.

The Malayan Insurgency (1948-1960) provides an example of a successful program to build and train indigenous security forces to defeat an insurgency. Although the insurgency ended more than forty years ago the strategic landscape is quite familiar. Many of the themes from the Malaya campaign resonate with the insurgencies being fought today: an insurgency based on ethnic divisions; the impact of human rights abuses by security forces, the difficulty of collecting intelligence on insurgents; and the role of the security forces; in maintaining governmental legitimacy. Moreover, the process of training and employing the Malayan police and military forces provide some very timely and enduring lessons about leadership in counterinsurgency campaigns. The first three years of the Malaya campaign are a mostly depressing story. The government forces started at a disadvantage and the insurgency grew rapidly in size and capability as the government and military fumbled through a series of relatively ineffective programs and operations. Yet the government and military leaders learned from their mistakes and eventually developed a highly effective strategy to win the war. This paper will focus on one of the key elements of the successful British strategy in Malaya—the program to build and train the Malayan Army and Police.

### **Overview of the Malayan Insurgency**

The insurgency in Malaya, called the “Emergency”, lasted from 1948-1960 and was born of the post-World War II disorder coupled with the rise of nationalism. The conflict also had an ethnic dimension as the insurgent ranks were drawn overwhelmingly from the Chinese ethnic minority. However, calling the Chinese a minority is almost a misnomer as they constituted 42% of the population of the Malayan Federated States and Singapore with ethnic Malays making up 40% of the population and rest consisting of Indians and aboriginal peoples.<sup>3</sup>

During World War II the Malayan Communist Party, dominated by ethnic Chinese, expanded and organized its cadres. Many Chinese, targets of especially harsh treatment by the Japanese, fled to the jungle regions where they became willing recruits for the Malayan Communist Party. The communists organized thousands of these refugees as guerilla fighters who received arms and training from the British army. After the war the communists—now well-armed and well-organized—saw the opportunity to drive the British out of Malaya through a peoples’ war reminiscent of Mao’s concepts. A force of well-trained and well-equipped insurgent combat troops was supported by tens of thousands of civilians who provided supplies, money and intelligence to the fighters. Government institutions and security

forces, as well as the valuable tin mines and rubber plantations, were targeted in a guerrilla campaign. Malaya was a protracted war comprised of thousands of small engagements and most of the insurgent activity consisted of bombings, assassinations, small raids and ambushes. The civilian population was coerced into providing support to the insurgents while community leaders who refused to cooperate with the rebels were targeted for assassination.

### **The First Phase of the Insurgency, 1948-1951. Malaya Police Operations**

In Malaya, as in most counterinsurgency operations, the line between law enforcement and military operations was blurred. For the most part, the military provided support for essentially police operations such as search and cordon operations, roadblocks, and area pacification. In Malaya, the police fielded not only cops on the beat but also special infantry companies trained in jungle warfare and armored units for local security. Throughout the war the police usually served as a lead combat force, and took twice as many casualties as the army.<sup>4</sup>

Police operations were central to the war as the police maintained daily contact with the population, which was also the source of insurgent recruits and support. Generally the military units were shifted around the country and concentrated their efforts on large operations and long term operations, such as patrols in the deep jungle. Because insurgent membership or activities in Malaya were considered criminal offenses, the police retained the primary responsibility for the arrest, detention and interrogation of insurgents. Insurgents were prosecuted in civilian courts and subject to long prison sentences or the death penalty for a wide variety of insurgency-related offenses specified under emergency regulations.

In 1948 the Malaya Police were in no shape to deal with an insurgency. The losses and disruption of the World War had left the Malaya Police demoralized and disorganized and the force needed to be rebuilt after the end of the Japanese occupation in 1945. Progress was slow because Malaya was in the midst of a wave of postwar lawlessness that simply overwhelmed the undermanned police force, fewer than 10,000 for a country of eight million.<sup>5</sup> The Malaya Police were unable to cope with basic law enforcement requirements, much less fight well-organized insurgents. Indeed, in the first years of the insurgency the Malayan Police were an easy target for the insurgents. While the urban police forces were fairly well-trained and had some experienced officers, the rural police were generally organized into small detachments under command of Malayan NCOs. As was common in the British Empire, colonies had some centrally-controlled and professionally-led police forces to oversee the urban areas, and far less capable “native police” who dealt mainly with the countryside and served more as a symbol of government

power than as a force to serve the public.<sup>6</sup> As is common in developing countries, the rural police in Malaya were complacent at best, and more often corrupt, augmenting their police salaries with small bribes extorted from the rural residents. As the insurgency began, the rural police, the first line of government authority in the most threatened regions, were generally incapable of mounting energetic action when confronted by a terrorist or guerrilla threat. Many of these police detachments simply avoided trouble. Other detachments surrendered themselves and their weapons without a fight to small insurgent bands.

When the government formally declared the Emergency in June 1948, the most urgent requirement was to put enough police and troops on the ground to provide some security in the cities and to protect the nation's infrastructure. The need to rapidly expand the police force meant discarding the pre-insurgency standards and training program. Thirty thousand new Malaya Police recruits, called special constables, were hastily organized into small detachments to conduct counterinsurgency operations in each district. The first major problem was the lack of competent leadership. Prior to the World War most of the experienced policemen of officer rank were British, but this group had been decimated by the war and few Malaysians had been trained as officers.<sup>7</sup> In response to the urgent manpower requirements some Malaysians were promoted from the ranks without undergoing an officer training course and other officer positions were filled by young men recruited in the UK. Many young Britons with some military experience were quickly commissioned, given a few weeks training, and then found themselves in Malaya commanding police detachments fighting insurgents.<sup>8</sup> The police recruit training program was drastically cut and from 1948 to 1951 most training was "on the job."<sup>9</sup> In 1949 the Malayan government reported that manpower requirements were so urgent that no higher police training for officers and NCOs was taking place. Basic skills training, such as vehicle maintenance and communications, had also fallen out.<sup>10</sup>

### **The Malayan Army 1948-1951**

At the start of the conflict the army was in no shape to conduct a counterinsurgency campaign. The postwar British military was in a state of flux, and units contained a high proportion of short term national servicemen (conscripts). On paper the thirteen battalions of the British Army garrison in Malaya (the strategic reserve of imperial forces in the Far East) looked an impressive force. However, training levels were low and what training took place was all for conventional warfare. The several Gurkha battalions that were the core of the force were all under strength and contained a high proportion of new recruits who had not completed basic training.<sup>11</sup> Other British units in Malaya were at half strength and lacked basic equip-



ment.<sup>12</sup> The government quickly reinforced the army and by 1951 the force had increased to 22 battalions including Gurkha, British and Malayan units.

In 1948 the Malayan army, a force then subordinate to the British army, consisted of three battalions of the Malay Regiment. Two battalions were available for operations and one was in the process of being formed. The Malay Regiment had all-Malay enlisted men commanded by seconded British officers, and non-Malayans were officially excluded from joining. Like the Gurkha and British units, the Malay Regiment was trained for conventional warfare, not for jungle operations or counterinsurgency. In 1948 the government decided to quickly double the size of the regiment and add three more battalions by 1950.<sup>13</sup> However, the program to expand the Malayan army proceeded slowly and by early 1952 only one additional battalion had been added to the force.

### **Intelligence Operations 1948-1951**

In Malaya effective operations depended more on accurate intelligence than any other factor. The police and army could defeat the insurgents—*if* they could find them. The problem was finding enemies who recognized no front lines and who could easily blend in among a sympathetic civilian population. Lacking accurate intelligence, conventional forces could only blunder about in the usually vain hope that the enemy guerrillas would decide to stand and fight—which they rarely did unless cornered or when the odds were in their favor.

In the first phase of the insurgency (1948-1951) the biggest obstacle for the government was the lack of intelligence. Mass arrests and detentions of civilians yielded some intelligence, but at the considerable price of alienating much of the population. Many civilians who might have provided intelligence kept quiet for fear of insurgent retribution. With little accurate intelligence the reinforced army garrison, which numbered over 40,000 troops by 1950, spent most of its time blundering about the jungle that covered most of Malaya. The army's slow and clumsy sweeps were easily evaded by the more agile rebel bands. The big conventional operations favored by the army yielded few concrete results in the form of insurgent prisoners or casualties.<sup>14</sup>

Insurgent combatant forces, which reached a peak of an estimated 10,000 active fighters in 1951, were only the tip of the iceberg. The fighting units depended on an underground network of 100,000-plus party members and many other active supporters among the civilian population who provided support for the guerrilla fighters. The government's intelligence effort not only had to locate the insurgent combat units but also had to break the underground support network. Even if the

security forces killed large numbers of insurgents in the field, the insurgency could still thrive as long as the support network survived and could funnel more recruits, funds and supplies to rebuild the combat units. Since the support network consisted mostly of civilians, breaking this network was primarily a police job.

At the start of the insurgency the Malayan Police had very few officers with a suitable background for intelligence work. In 1948 the Malayan Police had only the CID (Criminal Investigation Division) with a small group of officers capable of manning a Special Branch (British term for a police intelligence organization). The government had only a small intelligence staff, the Malayan Security Service, which provided domestic intelligence to the governor general mainly concerning political groups and labor unions.<sup>15</sup> Collection and analysis of intelligence on the insurgents was carried out by the small and overworked CID, which was also responsible for investigating normal crimes. The undermanned CID and Malayan Security Service failed to coordinate their efforts at first, although the situation improved somewhat after General Briggs took over military command in 1950 and instituted a committee system that pushed the military and police to coordinate their efforts. The police created a police Special Branch in August 1950 as a means to direct and coordinate the intelligence effort.<sup>16</sup> However, since higher police training was suspended at the start of the emergency, there was no formal system for training intelligence personnel. As with the regular and special police force, training was “on the job.”

As well as a shortage of trained personnel, the police faced other problems that limited intelligence collection efforts. The most crucial problem was the lack of language skills. Although the great majority of insurgents belonged to the 42% of the population that was ethnic Chinese there were very few policemen of Chinese ethnicity, and almost none of the Malayan or British intelligence personnel knew Chinese.<sup>17</sup> The lack of Chinese in the Police or Malayan civil service was a major obstacle in responding effectively to unrest that was primarily centered in the Chinese community. All the Malayan state governments were dominated by ethnic Malays who regarded the Chinese as outsiders and competitors. For decades the Malays had excluded the Chinese from the ranks of government service. When the British took control of the Malayan states in the 19th century the colonial administrators adopted a pro-Malay and anti-Chinese viewpoint and they discouraged Chinese recruitment into the Malay-dominated police force.<sup>18</sup> The insurgency reinforced the anti-Chinese prejudice among the British and Malay leadership. Since all Chinese were viewed as likely terrorists nothing was done between 1948 to 1951 to recruit ethnic Chinese into the Malayan military or police. The British prejudice against the Chinese was largely due to a desire to accommodate the Malayan ruling groups. It was, perhaps, understandable for the British soldiers and

policemen sent out to fight insurgents to view the Chinese as the enemy and the Malays as friends. However, it was also an unjust prejudice considering that during the Japanese occupation it had been the Malays who had actively collaborated with the Japanese and the Chinese who had gone into the jungles and fought as guerrillas alongside the British.

The general exclusion of Chinese from the government and security forces meant that the Chinese community would continue to view the government with hostility, or at best, indifference. Police intelligence collection and analysis had to rely on the few Chinese-speaking personnel already in the police or other branches of the government. Only in 1951 did the government begin a serious effort to train the police and civil service in the Chinese language and six-month intensive language courses were organized. The first group of trainees included twenty police and four civil servants.<sup>19</sup>

### **Jungle Training Established**

One of the main advantages of the insurgents was their ability to live and operate in the jungle that covered most of the Malayan Peninsula. Thanks to their wartime guerrilla experience the insurgents were comfortable in the jungle. In contrast, the jungle was an alien place for the Malayan Police and British soldiers. In the first years of the Emergency the conventionally-trained British and Malayan Army battalions mounted large operations in the jungle that resulted in few contacts and no notable victories. The small guerrilla units worked the rugged terrain to their advantage and the dense jungle neutralized the British superiority in firepower and conventional mobility. The guerrilla bands could leave the jungle at will, ambush police patrols or raid mines and plantations and retreat to their secure jungle hideouts. British Army veterans of the far eastern campaigns of World War II knew that the best way to seek out and destroy small bands in jungle terrain was to employ light infantry patrols that could play the insurgents' game of raid and ambush on the insurgents' home ground.

Fighting in the jungle required retraining the army and police for a very different kind of war and at the start of the Emergency Colonel Walter Walker, a veteran of the Burma Campaign, set up the Jungle Warfare School. The school, staffed by Burma veterans who knew jungle combat and survival, taught army and police personnel small unit patrolling and tactics and each course ended with a series of realistic exercises.<sup>20</sup> The course was very effective but was limited by its small capacity at first. In the early years of the insurgency the school could only train a few of the army and police leaders who would be expected to train their subordinates in the jungle lessons they had learned. Later the school was expanded and

whole police and army units were trained in the course. As more police and army personnel were fully trained in jungle warfare the competence of the police and army units improved and the government forces were able to put the insurgent base areas under constant pressure.

Although jungle operations were mainly an army responsibility, the police were also heavily engaged. In 1949-1950 the Malaya Police stood up 500 squads of 12-18 men each to search out insurgent bands in the jungle. As with the army, initial operations were hampered by the lack of training and competent leaders. While some police detachments were effective, most found that learning jungle warfare on the job was a costly process.<sup>21</sup>

In November 1950 the police jungle squads were reorganized into special light infantry companies, composed mostly of Malaysians with British officers, and 21 police jungle companies, each 180 men strong, were formed by August 1951.<sup>22</sup> Each company was a stand-alone force with its own communications, supply, transportation, and heavy weapons sections. Each company was deployed to cover an assigned district. The striking portions of the police companies consisted of detachments of 10-15 policemen who conducted jungle patrols for days and even weeks. To support these offensive operations the police set up fortified bases deep in the jungle regions. RAF aircraft and helicopters were able to keep police and army detachments supplied—even in the most inaccessible regions of Malaya. The deployment of RAF transport helicopters to Malaya in 1952 was a big step forward and by 1955 light and medium RAF helicopters were able to effectively sustain police and army jungle units and further increase the pressure on the insurgents.<sup>23</sup>

### **Human Rights Abuses by Security Forces**

By 1950 the downside of throwing a large number of poorly trained police and troops at the insurgency became evident. Low police recruiting standards brought a bad element into the police, and the lack of supervision afforded many new policemen the opportunity to abuse their power.<sup>24</sup> The Malaya Police won a well-deserved reputation for widespread corruption and brutality, especially in their dealings with the ethnic Chinese—all of whom were viewed as insurgents or potential insurgents.<sup>25</sup> The 1950 Police Commission to Malaya noted that the problems of bribery and corruption existed in a high degree throughout the Malayan government, especially in the lower ranks of the police. Furthermore, the Police Commission viewed police corruption as a major source of the people's dissatisfaction with the government. Bad policemen made it easy for the insurgents to recruit new fighters and supporters. The Commission noted, "The insidious cancer of corruption eating into the system of government may render impotent its vital

services, including its police force.”<sup>26</sup> The problems of police corruption and brutality had been overlooked in the rush to expand the force in 1948-1949. Now the government was paying the price in inefficiency and in increasing support for the insurgents.

By 1951 the government was making no headway against the insurgency despite its overwhelming advantage in manpower and resources. That year violent incidents notably increased and support for the insurgency among the populace was growing. That year there were 6,082 recorded incidents in which 533 civilians, 354 policemen and 124 soldiers were killed, for insurgent losses of 1,078 killed and 322 captured.<sup>27</sup> Although insurgent losses were heavy, their numbers continued to grow with the active insurgent fighters reaching their peak of over 8,000. The situation for the police was especially bleak. In 1951 the police commander in Perak reported that the police were no longer an effective force in his state. Desertions were frequent, morale was low, and there were increasing instances where police failed to stand up to the insurgents or even surrendered to them. Numerous breaches of discipline were reported, including the shooting of innocents and the refusal of police to carry out duties.<sup>28</sup> At the top, it looked like the British strategy in Malaya was foundering as things looked equally bleak. In late 1951 it appeared that the British strategy in Malaya was foundering as the British Defence Coordination Committee in London reported: “The communist hold on Malaya is as strong, if not stronger, today than it ever has been. This fact must be faced.”<sup>29</sup>

### **New Leadership- New Policies**

The British elections of October 1951 put the Conservatives, led by Winston Churchill, back into power. The new colonial minister, Oliver Lyttelton, had worked as a businessman in Malaya in the 1930s and knew the country. He flew to Malaya for a three week tour to assess the situation and was disturbed by what he saw and returned to London with the conclusion that a completely new leadership team was required in Malaya. Lieutenant General Briggs, military commander in Malaya from April 1950 to late 1951, had performed well and initiated important reforms to improve police and military cooperation. However, poor health forced his retirement. In October 1951 General Gurney, the high commissioner, was ambushed and killed by the insurgents. At the same time, the government decided to relieve the Malaya Police commander, Colonel Grey, since both the government and his subordinates had lost confidence in his leadership.<sup>30</sup>

Field Marshal Montgomery, Chief of the Imperial General Staff, agreed with Lyttelton that new leadership was required to handle Malaya. In a letter to Lyttelton, Montgomery explained the basic requirements for a successful strategy for

Malaya, "We must have a plan. Secondly, we must have a man. When we have a plan and a man, we shall succeed: not otherwise."<sup>31</sup> In General Briggs' program to reduce aid to the insurgents by moving many of the Chinese living on the edge of the jungle to new villages where they could be more carefully controlled by the government the government had a plan that addressed some of the issues driving the insurgency. Now the government needed to find the right man. After careful consideration General Gerald Templer was named as both the high commissioner and the military commander in early 1952. By combining both the civil government and military command under one hat the government in London hoped to reduce the friction between the branches.<sup>32</sup> Templer was an inspired choice. He combined a first rate record as a combat commander in Europe during World War II with extensive experience in dealing with civilian issues. He had served in imperial garrisons before the war and, more recently, had been chief of the British military government in Germany. This last experience was important as Templer had to deal with a wide variety of non-military issues and under a mandate to help the German people develop democratic institutions at all levels.

The next major leadership appointment was also an inspired choice by Lyttelton. He asked Sir Arthur Young, Commissioner of the City of London Police, to come to Malaya for a year to take command of the very troubled Malaya Police. Young was considered to be one of the top policemen in the Empire and had previously accepted missions to command and reform colonial police forces in trouble. Young arrived in Malaya in early 1952 and, at Templer's request, stayed an extra three months and returned to London in mid-1953. Templer and Young made a superb team for turning the situation in Malaya around. Both men made a thorough study of Malaya before coming out and talked extensively with officials, soldiers and policemen who had just returned from Malaya.<sup>33</sup> Both men arrived well briefed and with a clear idea of the issues that needed to be immediately addressed. In recommending major changes in policy and in requesting additional funds and support for the counterinsurgency campaign, both men had the full support of Lyttelton. Since many of the British soldiers in Malaya were conscripts, the Churchill government was under heavy political pressure to pull British soldiers out of Malaya as soon as possible. British defense spending at the time was already exceptionally high (from 1949-1956 it ranged between 7-10% of British GNP) and British defense commitments to Europe and other imperial concerns were straining the force. Yet, despite the limited resources and political pressure to reduce British forces, Lyttelton stood by Templer when the new high commissioner insisted that the British government commit to maintaining large British military forces in Malaya until the Malayan security forces were fully prepared to assume their task.

### **Reforming the Police-- 1952-53**

On assuming command, Templer and Young insisted on a complete overhaul of the Malayan Police organization, training and leadership to make it capable of taking over the counterinsurgency effort. The program to adequately arm and equip the police had proceeded slowly in the first three years of the insurgency, so Young moved quickly to improve police armament. Templer quickly approved Young's request for 120 armored cars, 250 armored scout cars and 600 armored personnel carriers for the police. Units in the field received submachine guns and 12-gauge shotguns for jungle fighting.<sup>34</sup> Young's next step was to retrain and reform the police.

Upon his arrival Young recalled, "The lack of training was everywhere evident. The pressure of the Emergency to increase the numbers of police and auxiliaries had allowed no time to train the thousands of newcomers who were employed almost exclusively upon guard and static duties. I considered the need for training as of top priority and arranged for training depots to be set up in regional areas with a program to complete the training of the force within twelve months so that the police could be progressively employed on active anti-terrorist duties rather than on their existing passive ones."<sup>35</sup> Young initiated a comprehensive program to retrain the entire police force over an eighteen month period. He cut back on police operations against the communists while the special constables were pulled out of action and sent to a two-month basic training course. Templer was upset with the extra burden placed upon the army, who had to carry out operations with less police support, but Young persuaded him on the issue.<sup>36</sup> To oversee his ambitious training program Young brought in a team of top policemen and intelligence specialists from Britain. Superintendent John Kane, Commandant of London's Metropolitan Police School, one of the world's top police training schools, took charge of the police training program. To staff the training program Young ordered seventy of the most experienced Malayan Police officers and NCOs out of the field to serve as instructors at the new Police Training School in Taiping. From General Templer Young also requested, and got, army instructors for weapons, signals and other specialties.<sup>37</sup>

The new commanders and the government in London realized that the old model of colonial warfare and policing did not apply to Malaya. At the end of World War II the British government anticipated that Malaya would remain a colony for the next 25 years and would be slowly prepared for independence. However, by 1952 several Malayan political parties had formed and nationalist sentiment among the Malays was strong. Having already granted independence to several colonies the British leadership realized that independence for Malaya would come sooner rather than later. Therefore, Templer and Young made Malayanization of

the military, police and civil service leadership a top priority. Young moved aggressively to build an effective corps of Malayan leaders for the Malayan Police. In 1952 he hand-picked twenty-nine of the best Malayan police officers to go to the year-long UK police college courses. That same year Young opened a new police college for officer training at Selangor. The school aimed to replicate the UK model and standards of professional police training, then probably the best in the world, for the Malaya Police. The school included an eight-month course for new policemen selected for the officer program, and a three-month course for officers who had already been commissioned but had not attended a proper police course. Other officers were sent to 4-8 week courses at the new police training centers.

Full training for the NCOs and enlisted policemen was instituted and over 3,000 policemen were trained at the Federal Police Depot. Chinese language training for the police was stepped up and forty-six police officers destined for the Special Branch went to Chinese Language School in 1952.<sup>38</sup> Hundreds of police officers and enlisted men were sent to army courses in subjects such as vehicle maintenance, communications operations and weapons repair.<sup>39</sup>

As a move to improve the efficiency of the force and to improve police relations with the public Young made the radical move of reducing the force by 10,000 personnel in 1952, cutting from the force many special constables who had proven incompetent or corrupt. Fighting corruption in the police force was a major theme of Young's tenure, and hundreds of police were dismissed for cause. Other special constables that had been quickly recruited in 1948 were found physically unfit, illiterate, or otherwise disqualified from police duties. These personnel were sent to job training programs as they were demobilized from the police.<sup>40</sup> Cutting corrupt and incompetent police personnel raised the efficiency and morale in the force and also provided Young some of the funds to finance his comprehensive training program.

While the Police Jungle Companies engaged the rebel forces in rural areas, Young worked to improve the police image among the town and city dwellers. Generally the police were viewed as an authoritarian arm of the government and Young wanted to change this perception. He wanted the population to consider the police as a branch of government dedicated to public service and not a group to be feared and avoided. Improving police relations with the public was vital because it led to a marked improvement in the intelligence coming from the public. To change the public's negative perception of the police Young instituted "Operation Service." Police detachment commanders, even individual policemen, were expected to perform some public service on a daily basis. Additional police duties included helping civilians to get care at government health clinics and helping



peasants with applications for plots of government land.<sup>41</sup> The idea that the police existed to serve the people at large was a new concept for Malaya as most Malaysians feared the police — usually with good reason. With Operation Service, Young hoped that the policeman would be regarded as a friend, not an enemy, of the average citizen. In fact, the program was surprisingly effective in changing the attitude of civilians towards the police.<sup>42</sup>

Other measures were initiated to root out police corruption. In 1953 work began to establish a police commission to provide outside oversight of police promotion policies, and to investigate serious breeches of discipline. The group was formally established in 1956 and worked to improve the professional standards and behavior in the Malaya Police.<sup>43</sup>

### **Improving the Ethnic Balance of the Malayan Security Forces**

Templer understood that the deep social and political divide between the Malays and the Chinese was one of the root causes of the insurgency. If the Chinese were not granted a role as partners in Malayan society any Malayan government would be standing on a weak foundation. Templer pushed the Federation governments to admit Chinese to the civil service and into the security forces with the goal of making the Malayan army and police forces representative of all of Malaya's groups.<sup>44</sup> In championing integration of the Chinese into the government and security forces Templer and Young encountered considerable resistance from the old Malaya hands of the British military and civil service who viewed the Chinese as a totally hostile group and favored the continuing the policy of exclusion. Luckily for the British, some of the Malay political leaders had also concluded that an independent Malaya required a partnership with the Chinese and were willing to cooperate with Templer in supporting reforms. Tunku Abdul Rahman, leader of the Malay nationalist UMNO party began to forge alliances with the moderate Malayan Chinese political groups in the 1952 municipal elections. As the political cooperation between Malays and Chinese slowly improved the Chinese support for the insurgency declined.<sup>45</sup>

Integration of the security forces made enormous progress under the leadership of Templer and Young. At the start of 1952 there were only 800 Chinese in the regular police force of over 20,000. Colonel Young put a high priority on recruiting Chinese for the regular police and established friendly relations with the Chinese associations and ethnic Chinese leaders to win their support to recruit Chinese into the police. He conducted a recruiting campaign through public radio broadcasts and private appeals to Chinese leaders and Chinese enrollment in the police improved significantly.<sup>46</sup> By November 1953 the Malayan Police included 1,824

Chinese in the regular force of 22,934. Although it would take decades to right the ethnic imbalance in the police, Young made a good start.<sup>47</sup> Indeed, the increased numbers of Chinese in the force had some immediate benefits for the counterinsurgency campaign. First of all, with many more Chinese speakers on the force intelligence dramatically improved. Secondly, the increasing numbers of Chinese on the police force served to reassure the Chinese community that they would be granted a full partnership in an independent Malaya and served as a convincing argument for the government's propaganda campaign.

### **Building a Malayan Army**

The program to build up the Malayan army had languished in the first three years of the emergency and Templer quickly moved to accelerate the program to equip the Malaysians and to see that proper training facilities were made available. As with the police, a high priority was placed on recruiting Chinese for the enlisted and officer ranks of the Malayan army. Although the Malayan Regiment remained closed to all but ethnic Malays, Templer ordered new units to be established that would recruit from all the Malay ethnic groups. The new army units formed between 1952 and 1954, such as the Armored Car Regiment, the Federation Regiment and the technical and support branches of the army were opened to all the ethnic groups of Malaya. Despite Templer's efforts the Chinese were not enthusiastic about joining the army, so that force remained overwhelmingly ethnic Malay throughout the insurgency. Only 15% of the new Federation Regiment's personnel were Chinese, although a higher percentage of Chinese signed up for the army's technical and support services. Although Templer failed to meet his ambitious goals of recruiting a large number of Chinese, enough Chinese recruits and officer cadets joined to make the Malayan army credible as a multiracial force.

In order to provide competent leadership for the Malayan army Templer increased the flow of Malayan officer cadets to Sandhurst to receive the full year-long officer course provided by the British army. In 1952 Templer personally selected two dozen of the top officer candidates to be sent to Britain for training and ensured that some Chinese cadets were included in the group. In 1953 Templer opened a Malayan officer school which would serve to replicate the full Sandhurst professional course. Templer appealed to Sandhurst to provide faculty to stand up the Malayan Army Officer School and 17 faculty members volunteered to come to staff the Malayan school.<sup>48</sup> In 18 months the Malayan Army went from four to seven battalions available for operations in the field. While most of the Malayan army officers were seconded from the British army, by 1954 the new Malayan officer course was beginning to provide a steady stream of properly trained Malayan officers. In 1953 the first increment of the Sandhurst-trained Malayan officers ar-

rived back to reinforce the rapidly—expanding Malayan officer corps. In October 1953 Templer was able to form the 1st Federation Division of the Malayan Army and the development of a modern Malayan military was accelerated.<sup>49</sup>

### **Intelligence Training**

Malaya was considered an “intelligence war” and, as an experienced policeman with colonial experience, Arthur Young argued that no progress could be made against the insurgents until the very weak police intelligence system was improved. He built up and reformed the Malaya Police Special Branch and assigned one fifth of the senior ranks in the Malaya Police, usually men with criminal investigation experience, to intelligence duty. Young also brought in from London a highly qualified policeman, Claude Fenner, to establish a Special Branch Training School for the Malaya Police.<sup>50</sup> All senior Malaya Police officers and all Special Branch personnel were required to take courses in intelligence operations and analysis.<sup>51</sup> During 1952, 277 police officers attended the new Special Branch intelligence training courses along with dozens of army officers.<sup>52</sup> Army and police intelligence sharing quickly improved, and much of the credit goes to the Special Branch School. The school succeeded not only in providing officers with the skills necessary for effective intelligence operations, but also served to improve the professional skills of police leaders by including courses on the latest investigative techniques and police equipment.<sup>53</sup> Forty-six additional officers were also selected for Chinese language training, to be assigned to Special Branch when they returned.<sup>54</sup>

The payoff for the intelligence training program was dramatic. Within months of the start of the intelligence training program, the military and police forces in the field were able to target rebel bands much more effectively than before. Guy Madoc, who served as Special Branch director, commented “the school was the sluice valve of the Emergency. Defeating the Emergency depended on intelligence. Intelligence capacity depended on the output of the school.”<sup>55</sup>

### **The Home Guard Program**

Early in the insurgency the Malaya Federation governments authorized the establishment of village home guards. These home guards had no uniforms, received no pay and had few weapons, usually a few old rifles and shotguns. Training was minimal from 1948-1951 and the army provided little support to the force. The home guards served purely as a local security force to guard the villages at night, essentially to stand shifts at village gates and watchtowers. By 1951 an estimated 100,000 Malaysians belonged to the home guards, each member mounting guard

for a few hours a week. While of minimal tactical or operational value, these irregular local defense units were useful in giving many Malaysians a greater sense of security.<sup>56</sup>

Templer saw the value of the home guards as a personnel reserve that could free up police and army units from static security duties and could support the regular security forces in operations such as manning checkpoints. An increase in the size and efficiency of the home guards could also serve to support the policy of Malayization of the war. For a relatively small investment in regular personnel, equipment and training support, the home guards could serve as a major force enhancement. Templer sent for an experienced British officer recently retired from the army, Major General Edward de Fonblanque, to take charge of the haphazard home guard program, and created for Fonblanque the post of Inspector General of the Home Guard. Templer had some experienced British and Commonwealth officers assigned to the home guard and ensured that each Malayan state set up a training camp and program for the home guards. The goal was to enable the home guards to assume some of the most basic security duties. Firearms handling was the major element of the home guard training. The home guard was to be expanded to 240,000 men, and would be properly supervised by regular officers who would train the force and conduct regular inspections of the local units.<sup>57</sup> Each Malayan state set up a home guard headquarters to direct the training programs. The home guards developed basic manuals for weapons handling and village security and made sure that the local detachments were properly organized. Each of the states raised "operational sections", small units composed of the best home guardsmen, who were paid, given extra training, and made available to go on patrol with the regular police and army units.<sup>58</sup>

Templer broke with the policy of his predecessors who had staunchly refused to allow the creation of ethnic Chinese home guard units. Templer placed a high priority on recruiting Chinese into the home guard and making the Chinese community fully responsible for defending their own villages. Although many of the British and Malays feared that the Chinese would defect with their weapons to the rebels, these fears proved groundless. By 1954 50,000 Chinese had willingly joined the home guards and 150 Chinese villages were being protected by their own security forces.<sup>59</sup>

Although the home guards saw little in the way of combat in Malaya they were still a key force in helping suppress the insurgency. The home guards were able to assume many routine security duties, and freed up thousands of regular police and military personnel for offensive operations. Moreover, recruiting the Chinese into the home guard had the very positive political effect of bringing a large number of

the Chinese into the government process and making them part of the solution to the insurgency.

### **The Tide Turns—1954-55**

Improved intelligence helped give the government forces the initiative by 1953. Instead of unproductive sweep operations, the police and army could target specific rebel bands with a good idea of their size, leadership, armament and habits. In the cities, towns, and villages the police were better able to identify the insurgent cadre and supporters and arrest them or, better yet, convince them to switch allegiance to the government. Rebel combatant forces fell dramatically from over 8,000 in 1951 to 3,500 in 1954. The number and scale of insurgent attacks also dramatically dropped, as did government casualties. By 1955 one third of the districts were declared “white areas”, regions clear of insurgent activity where emergency regulations could be lifted.<sup>60</sup> By 1955 the insurgent policy was to simply survive and avoid contact with police or army units—a far cry from the start of the insurgency when the police and army were singled out for rebel attacks. From 1953 to 1960 Malaysians took over the counterinsurgency effort and systematically cleared districts of insurgents. The British granted Malaya independence in 1959 and in 1960 the Emergency was declared over.

The Malayanization program was especially effective. From 1953 onward, the Malayan Police were able to take over the leadership of the Special Branch while maintaining that branch’s efficiency.<sup>61</sup> The increased number of the ethnic Chinese in the force was also essential in improving the intelligence effort. With reforms in the police, the Chinese population took a more positive view of the police and the insurgents had to operate among an increasingly unfriendly population. With notable improvements in the Malayan Police and army forces, the British government was finally able to reduce the number of British army battalions and progressively turn over more of the military operations to well-trained Malayan units. In mid-1954 British Army strength in Malaya (not counting Gurkha battalions) was reduced from ten to four battalions. At the same time, the number of battalions available for operations remained the same (22).<sup>62</sup>

### **Conclusion**

The Malayan insurgency contains several elements common to most modern insurgencies. The insurgents declined to fight conventionally, employing instead a guerrilla and terror strategy to wear down the British will and intimidate the population. The insurgents relied upon the support of an aggrieved ethnic group and developed a large underground support network. At first, the insurgents were

also able to exploit the many weaknesses of the government security forces. The government was unprepared for the insurgency and required three years to build a comprehensive strategy. In the first years of the insurgency police corruption and human rights abuses undermined the government's legitimacy and increased public dissatisfaction with the government. The traditional policy of excluding a major ethnic group from the government and police ranks also fueled the insurgency and undermined the government's intelligence effort.

The British made numerous mistakes in the first three years of the insurgency in their haste to cobble together some form of strategy to face a new kind of nationalist insurgent war. The initial program to throw a large quantity of poorly trained and poorly led police and military forces at the insurgency was, in many respects, counterproductive. Poorly-trained and poorly-led forces were relatively ineffective against a capable insurgent force, but the consequent corruption and human rights abuses by poorly disciplined government forces helped fuel the insurgency. Young's comprehensive strategy of police training and reform was required to meet the insurgent challenge. By standing up highly effective jungle companies and armored units the Malaya Police demonstrated that they could be much more than "cops on the beat." Malaya provides a good example of how police can be a lead force in counterinsurgency. Although police combat operations were vital in securing victory, the most important contribution of the police was their work in intelligence collection and analysis. Young's program to establish the Special Branch School and recruit Chinese into the police rapidly improved intelligence collection and that, in turn, quickly took the initiative from the insurgents. All of these successful initiatives were based on Young's priority of training the police leadership and developing a cadre of Malayan police leaders trained in British professional institutions and to British professional standards that could take over command of the force.

Templer's program to emphasize training of the Malayan army leaders paralleled Young's approach and was also as successful. At the center of the successful strategy was the policy of encouraging the integration of the ethnic Chinese into the Malayan security forces. Although these programs met with considerable resistance of British and Malay leaders, they served to undercut the support for the insurgency within the Chinese community. Indeed, one of the decisive elements that defeated the insurgency was the decision of some of the Chinese and Malay political groups to work together to build an independent and multi-ethnic Malaya. Such a political development worked enormously to the advantage of the British. Although the initiative came from the Malays themselves, Templer very wisely encouraged and supported the beginning of Chinese and Malay political

cooperation through his program of Malayanization and encouragement of developing Chinese home guards.

Finally, the Malaya campaign provides a good example of effective senior leadership in a counterinsurgency campaign. The leadership team of Lyttelton, Templer, and Young proved exceptionally dynamic and competent. Colonial Minister Oliver Lyttelton steadfastly supported Templer when the new high commissioner insisted that London commit to maintaining a large British military force in Malaya until the new civil affairs strategy could take effect, and until the Malayan military and police forces could be systematically trained and prepared to take responsibility for Malaya's security. Lyttelton deserves credit for ensuring that Templer and Young got the troops and resources they needed, and for garnering political support for a long-term counterinsurgency strategy. Templer and Young worked effectively to develop competent leadership in the Malayan security forces and to lay a sound foundation for the development of an independent Malaya.

## Endnotes

1 On the British use of police in counterinsurgency there are several important works including: David Anderson and David Killingray, eds., *Policing and Decolonisation: Politics, Nationalism and the Police, 1917-1965* (Manchester: Manchester University Press, 1992). For an overview of the Malayan Police during the insurgency see: Government of Malaya, *The Federation of Malaya and its Police* (Kuala Lumpur: Government of Malaya, Dec. 1952).

2 James Willbanks argues persuasively that the US Army did poorly in building, training and advising the South Vietnamese forces and failed to prepare them to act effectively to take over the fighting. This was, in large part, due to the excessive emphasis by senior US officers on conventional war. See James Willbanks, *Abandoning Vietnam* (Lawrence: University Press of Kansas, 2004) see pp. 277-288.

3 On the Malayan population and ethnic groups see Lucian Pye, *Guerrilla Communism in Malaya: Its Social and Political Meaning* (Princeton: Princeton University Press, 1956) 12-13; T.H. Silcock and E.K. Fisk, *The Political Economy of Independent Malaya* (Berkeley: University Of California Press, 1963) 16-17.

4 Anthony Short, *The Communist Insurrection in Malaya 1948-1960* (New York: Crane, Russak and Co., 1975) 507-508. During the insurgency 1,346 police were killed, 1601 wounded, 519 military were killed, 959 wounded.

5 A good account of the police in the insurgency years is Dato' J.J. Raj, jr., *The War Years and After* (Selangor, Malaysia: Pelanduk Publications, 1995). see p. 56

6 Anderson and Killingray, pp. 2-5. For details on police training and organization in the British Empire in the 1940s and 1950s see: Sir Charles Jeffries, *The Colonial Police*, London: Max Parrish, 1952.

7 In 1948 only 188 Malaysians served at the rank of inspector, the lowest police officer rank. See *British Documents on the End of Empire*. Series B, Vol. 3, Malaya, Part 2. Ed. A.J. Stockwell (London: HMSO, 1995) Doc. CAB 129/48, "Malaya Cabinet Memo by Mr. Lyttelton" (Secretary for the Colonies) 20 November, 1951, 318-348.

8 An account of this era comes from Derek Franklin, a young man of middle class background in 1953. After his two-years of national service in the army, he joined the Kenya Police during the Mau Mau rebellion when police officers were urgently needed. He received only a few weeks of training in the local language and conditions before being assigned to command a Kenya Police unit. His experience was fairly typical of the era. Franklin went on to serve in three other colonial police forces. See: Derek Franklin, *A Pied Cloak: Memoirs of a Colonial Police Officer* (London: Janus, 1996).

9 In 1949-1950 the Singapore Police reported that there was no coordinated system of training police personnel after they left basic training at the police depot. Young Papers, "Report of the Police Mission to Malaya," March 1950; and "Singapore Police Force Organization," June 1949. Young papers are located at Rhodes House, Centre for Imperial and Commonwealth History, Oxford University.

10 Young Papers, "Memo by Creech Jones on UK financial assistance to Malaya," 8 June, 1949, 102-114.

11 In 1948 the Gurkha battalions in Malaya had an average of only 300 men. On Gurkha training and readiness in 1948 see: Raffi Gregorian, *The British Army, the Gurkhas*



and *Cold War Strategy in the Far East 1947-1954* (Hampshire: Palgrave, 2002) 46-50, 61. The poor state of training of the Gurkha units early in the campaign is documented in J.P. Cross and Buddhiman Gurung, *Gurkhas at War* (London: Greenhill Books, 2002) 190-191, 201, 203, 209.

12 Gregorian, 56.

13 Gregorian, 63-64.

14 A typical example of British operations in the early period was the North Malay Sub-District in which large unit operations in the second quarter of 1949 yielded one enemy kill and no captures or surrenders. See John A Nagl, *Counterinsurgency Lessons From Malaya and Vietnam: Learning to Eat Soup with a Knife* (Westport: Praeger, 2002) 78.

15 The Malayan Security Service was a small group, but could at least function as the nucleus of an expanded intelligence service. By the start of the insurgency the Malayan Security Service had compiled brief dossiers on leading Chinese communists and other political figures. The Malayan Security Service also translated captured communist documents and manuals. Some records of the Malayan Security Service are found in the Rhodes House Centre for Imperial and Commonwealth History at Oxford University. See: MS Ind. Ocean S 254 Report: "Threat of Communism in Malaya and Singapore," 26 June, 1947; and MSS Ind. Ocean S251/1948, "Malayan Security Service Supplement Number 10," 1948, Rhodes House, Oxford University.

16 Richard Clutterbuck, *Riot and Revolution in Singapore and Malaya 1945-1963* (London: Faber and Faber, 1973) 178-179.

17 A.J. Stockwell, "Policing during the Malayan Emergency, 1948-60: Communism, Communalism and Decolonization", pp. 105-125 in *Policing and Decolonisation: Politics, Nationalism and the Police, 1917-65*, eds David Anderson and David Killingray (Manchester: Manchester University Press, 1992) On Malayan demographics see p. 107.

18 In 1947 there were only twenty-six ethnic Chinese officers and inspectors in the entire Malaya Police. See Coates, 43.

19 "The Situation in Malaya", Cabinet Memo by Oliver Lyttelton, 20 Nov. 1951. CAB 129/48 in *British Documents on the end of Empire*, ed. A.J. Stockwell, Series B, Vol. 3, Malaya, Part II (London: HMSO, 1995) 310-347.

20 Major Scott McMichael, *A Historical Perspective on Light Infantry*, Leavenworth: US Army Combat Studies Institute, Research Survey No. 6, 1987, 125; see also Gregorian, 61; A good description of the Jungle Warfare Centre curriculum is found in Richard Miers, *Shoot to Kill* (London: Faber and Faber, 1959) 30-35. In some units there was an informal training course in jungle warfare taught by Burma veterans. For a description of one such training program see: Arthur Campbell, *Jungle Green* (Boston: Little, Brown and Co., 1953) 10-24.

21 Short, 286.

22 Government Report, "Malaya: A Review of Development in 1952, Part I," MSS British Empire 486 3/1. Rhodes House, Oxford University.

23 On air support to police and army forces in Malaya see James Corum and Wray Johnson, *Airpower and Small Wars* (Lawrence: University Press of Kansas, 2003) 179-199. On helicopter operations see: The Royal Air Force, *The Malayan Emergency 1948-1960* (Britain: Ministry of Defence, June 1970). 102-104.

- 24 John Newsinger, *British Counterinsurgency from Palestine to Northern Ireland* (London: Palgrave, 2002) 48.
- 25 Richard Stubbs, *Hearts and Minds in Guerrilla Warfare; the Malayan Emergency 1948-1960* (Singapore: Oxford University Press, 1989) 72-73.
- 26 *Report of the Police Commission to Malaya*, Kuala Lumpur, March 1950. Papers of Sir Arthur Young, Rhodes House, Oxford University. On the negative perception of the police by the public see Karl Hack, *Defence and Decolonisation in Southeast Asia: Britain, Malaya and Singapore 1941-1968*, Richmond, Surrey: Curzon, 2001, 127.
- 27 John Scurr, *The Malayan Campaign 1948-60* (London: Osprey, 1986) 22.
- 28 Short, 283-284.
- 29 British Defence Co-ordination Committee, 15 November 1951, CAB Papers, 310-315.
- 30 See footnote 2. *British Documents on the End of Empire. Malaya Part 2*. CAB Papers 129/48
- 31 Colonel David Benest, "British Leaders and Irregular Warfare" *British Army Review* No. 139, Spring 2006 . 7-11.
- 32 Templer had a good background to lead a counterinsurgency campaign. He served in Palestine during the 1930s revolt, served as a division and corps commander in World War II and then as director of the British military government in Germany. Few in the British military had a similar civil/military background. On Templer's background see John Cloake, *Templer: Tiger of Malaya* (London: Harrap, 1985).
- 33 The Young Papers in the Rhodes House Centre for Imperial and Commonwealth History in Oxford preserves much of Arthur Young's correspondence with Lyttelton, Templer and other British government officials.
- 34 Noel Barber, *The War of the Running Dogs* (New York: Weybright and Talley, 1971) 156.
- 35 Sir Arthur Young, "Malaya 1952: Narrative Report, 1967," Young Papers, Rhodes House, Oxford University.
- 36 Letter, Sir Arthur Young to Hugh Fraser, Officer Administering the Government, Kuala Lumpur, December 22, 1951. Sir Arthur Young Papers, Rhodes House, Oxford University, MSS Brit. Emp. S.486.
- 37 Cloake, 234.
- 38 Government Report, "Malaya: A Review of Development in 1952, Part I" MSS British Empire 48, 3/1. Rhodes House, Oxford University, 25, 31-32
- 39 Ibid. 32-34
- 40 Young Papers, "Malaya 1952: Narrative Report."
- 41 Victor Purcell, *Malaya: Communist or Free*, Stanford: Stanford University Press, 1954, 212-213.
- 42 Hack, 127.
- 43 *Report of the Police Service Commission*, Federation of Malaya, for the Years Ending 31<sup>st</sup> Dec 1957 and 1958 (Kuala Lumpur: Government Press, 1960) 1-3.
- 44 Purcell, 255, 229-230.
- 45 Brian Lapping, *End of Empire* (New York: St. Martin's Press, 1985). 176-184.
- 46 Purcell, 255, 229-230. 505 Chinese joined the Malaya Police between April and October 1952.

- 47 Purcell, 255, 229-230.
- 48 Cloake, 246-247.
- 49 Gregorian, 171-172.
- 50 Cloake, 234-235.
- 51 Young, "Malaya 1952: Narrative Report."
- 52 In 1952, 77 superintendents and assistant superintendents, 71 inspectors and 129 detectives passed through the Special Branch/CID courses. See Government Report, "Malaya: A Review of Development in 1952, Part I, MSS Brit Emp. 486, 3/1, Rhodes House, Oxford University, 34.
- 53 Nagl, 92.
- 54 Sir Arthur Young, "A Review of Development in 1952, Part I," Circa late 1952. Young Papers, Rhodes House, Oxford University, MSS Brit Emp. 486 3/1. 32.
- 55 Nagl, cited. 93.
- 56 A good description of the home guards system is found in John McCuen, *The Art of Counter-Revolutionary Warfare* (London Faber and Faber, 1966) 159-160.
- 57 Cloake, pp. 249-250.
- 58 "The Emergency in Malaya", *Army Quarterly*, April 1954, 46-65.
- 59 John Coates, *Suppressing Insurgency: An Analysis of the Malayan Emergency, 1948-1954*, Boulder: Westview Press, 1992, 120-121.
- 60 Robert Jackson, *The Malayan Emergency* (London: Routledge, 1991). 52-53.
- 61 Clutterbuck, 179-180.
- 62 Gregorian, 172.



## **Day 2, Panel 4 Question and Answers**

(Transcript of Presentation)

**Moderated by  
Dr. Lawrence Yates—Combat Studies Institute**

### **Dr. Lawrence Yates**

We'll open the session to some questions.

### **Audience Member**

I wanted to pose a question to Dr. Stewart and to, I'm sorry, the last presenter, about historical analogies. In the context of present operations, there is great attention to Vietnam. But for both of these conflicts, it seems to me likely, although you didn't address it, that the British were looking back, both to the Boer War and to Ireland as examples of their own experience with comparable conflicts. I'd like to ask to what extent did they do that and how did they try to draw on previous experiences to understand Malay. In Vietnam, I have no knowledge of what they looked back to as the past is prologue to comprehend their situation. Please address those.

### **Dr. James Corum**

The previous experience is interesting because sometimes previous experience hurts. The only group of people that the British had available with recent counterinsurgency experience in '48 were the recently unemployed Palestine police. The problem with the Palestine police is that they had been originally founded by the Black and Tans. And initially constituted from the old Black and Tans, which I would not hold as a model for an ideal counterinsurgency force. Commander Grey was a former Palestine policeman, had a strong arm, ruthless approach to counterinsurgency. In fact, in going through the correspondence, there's a lot of complaints about this, that this is the old Ireland and Palestine approach, which you notice were not successful. Was not winning the hearts and minds in Malaya and it was turning the population against them. But those were the people they had, and they threw in these ex-Black and Tans and they finally had to say this is not working, and they fired Gray. A lot of the earlier ... they realized that this is no longer Colonial war. They started thinking in '51, '52 that Malaya has got to become independent sooner rather than later, and then it becomes really a new kind of war in which they are preparing them for full independence. So it's not just suppressing the insurgents, the way they tried to do in Ireland and Palestine. They are thinking now, "Well, we have to build a nation. And we have to set firm foundations for a stable country." A pro-British stable country.

**Audience Member**

A follow-up directly on that. I'm not sure of the role that Winston Churchill played when he was Prime Minister in this time frame. It would seem to me that his perceptions of the war and the issues of dealing with native populations would have had some influence.

**Dr. James Corum**

Churchill came back into government in October '51, and he ... Churchill allowed Littleton ... Churchill is at the meetings, but Littleton is the lead man in the government. I think Oliver Littleton, again, he's become another one of my heroes. He's got to fight against Churchill in the Cabinet to push this Malayanization program.

**Dr. Richard W. Stewart**

Just as a follow-on to that, Churchill really didn't want to give up the Empire, and I don't think he ever forgot that notion. He believed he could deal with the problems and the new emerging nations pretty much the same way as they had done it in the glory days of the Empire. So I don't think he was the flexible, forward thinking guy in this particular instance. That's just my impression.

Vietnam is a little bit more problematic because there were, of course, some individuals who were able to draw on some political military experience, Edward Lansdale, an important one in the early days, trying to influence Diem to do certain things. British advisors were brought in from Malaya. I don't think that was entirely successful because again, going through the filter of Diem and his very corrupt leadership, the programs that he did begin based upon these other models were not successful. So when the US shows up, I don't think there's this fountain of experience, good or bad, to draw upon. They have plenty of historical experience they could have used perhaps, but it's indicative that, for example, they didn't arrange for the translation of the French after action reports from Vietnam until about 1967, because they weren't that interested in the French experience. A few individuals were, but as an institution, they weren't that keen upon learning from the French, because after all, they had lost. Not realizing that you can still draw a lot of experience from that. The big thing they should have learned, perhaps, from all of these situations is, since each context is different, studying up ahead of time for several months or years, is a good idea. What is different in the context? Let's think about that before we start implementing programs that may have worked somewhere else, but are not applicable here.

**Audience Member**

Thank you. I wanted to just propose a little challenge to the panel here. I was rereading Colonel Reese's introductory letter. We were all supposed to be doing research analysis and move toward policy recommendations. I didn't make any policy recommendations. I think Major Kron would recommend that we redouble our efforts to understand relationships, and I think Captain Alexander would like to see us build a better nation building capacity in our Civil Affairs units. The rest of our historians have not really made those recommendations. Perhaps I could ask Dr. Stewart if he's recommending that we do Civil Operations Rural Development Support (CORDS) in our current situation, or if any of the other panelists has similar recommendations for us.

**Dr. Richard W. Stewart**

Actually, we have sent a number of papers on CORDS to General Casey's headquarters, in hopes that they'll fall on fertile ground, simply because, even if you don't replicate CORDS, which, after all, was a pretty massive undertaking in a very different war, still the idea that you can have one manager in the military headquarters that will ... let's say it ... force US Agency for International Development (USAID) and the State Department, and US Department of Agriculture (USDA) and all the different elements to sit together and come up with a coherent plan and follow it and resource it, that would be a good thing, I would think, in addition, pouring more and more assets into building up different levels of the Iraqi forces and the Iraqi ministries and the Iraqi leadership. The one biggest single failure, perhaps, in Vietnam, and most of the people that I've talked to afterwards or have written about it say that the thing that we didn't do, was create a solid core of Vietnamese leaders. Civil leaders as well as military leaders. We, perhaps, did better in the military than in the civil department, who could then take over these programs and realize it was in their own self interest to push these programs and make them work. Pull back more and more from doing it ourselves, and relying more and more on their doing it with their own leaders, even with the mistakes they're going ...

*[Tape abruptly cuts off]*

**Dr. Lawrence Yates**

... military with the various detachments put into it. CORDS, as we've heard from Richard, is integrated civilian military. The decision was to go with the military, with the Security Assistance Forces (SAF) model and not the CORDS model in Panama, which did work out. The thing is, again, context. It's not to say a CORDS model wouldn't have worked in Panama, but for various reasons, including that

General Lindsay had a preference for the SAF, was trying to bring it back and did not, but they used that model.

**Dr. Richard W. Stewart**

Of course it's not going to work unless the State Department brasses up ... now they have 1,000 additional people in training as expeditionary State Department officers, and they hate that term and they hate the idea, but they're at least creating some. But they need to double and triple that amount, and Congress needs to give them the money to do that in order to pull up their part of the bargain.

**Audience Member**

Thank you. This question is for Dr. Stewart. When I was in Afghanistan, an AID official said to a friend of mine, "I hate this administration because he thinks the Ambassador is in charge of the Embassy and he makes us account for the money." Coordination within the United States Government (USG) is difficult enough, let alone coordination of other countries and independent Nongovernmental Organizations (NGO), and they all just think that they're king of their own domain. I was just wondering if you have any pointers on how you can sort of crack heads and make everybody sort of march to the same song.

**Dr. Richard W. Stewart**

Well, you need someone literally as abrasive and as obnoxious, I think, as Komer to get their attention first. As my father used to say when he was dealing with mules, which he did on a farm growing up. First you have to hit them with a 2 x 4 to get their attention. Then you can give them some direction and instruction. I think you need to do that to start with. But cracking heads only goes so far. Then you have to get their willing cooperation, which means working with them to get them the assets they need so that they can see it's in their own best interest to be able to tap into radios, vehicles, support, logistics and infrastructure that can help their program. So you need a little bit of a stick to start with, but a lot of carrot. Because yeah, they've got their own programs, their own agenda, their own cultures. And their cultures are sometimes antithetical to the military. That's why you have to blend them a little bit. Give them their head as long as they respond to some degree of centralized direction. But they're still going to fight and kick against the traces.

**Dr. Lawrence Yates**

Okay, we have three more questions. General Petraeus?



### **Lieutenant General David H. Petraeus**

You know, he didn't earn the name Blowtorch Bob for nothing, and we've all seen different folks in the interagency. Dick Clark is a recent example, and you can have mixed views about Dick Clark and so forth, but I'll tell you that I watched him work the interagency, for example, during the run up to Haiti and he was very, very abrasive, but he actually did harness the interagency, which is something that's rarely done. So I think, you know, really the point that you raise is where do you find really sort of tough, intelligent, hard nosed, and extraordinarily hard working leaders who are going to try to pull everyone together, willingly or not? I wanted to add a footnote on what Larry said.

First of all, by the way, Larry you've been very modest and not noted your own contribution to the scholarship in the field, but Larry wrote a recent book called *The Military's Experience in Stability Operations*, and I think to summarize, the essence is that we've done a lot of stability operations, we've learned a lot, and we've generally forgotten what we learned ... I wouldn't say as quickly as we could after each of them, but certainly after the more painful ones. In particular, as Richard mentioned, Vietnam probably heading that list. For what it's worth, the new capstone Operations Field Manual that's going to be released this fall—different from the counterinsurgency manual—but the big idea in that manual is that we conduct full spectrum operations and that everything that we do is always some mix ... everything ... some mix of offense, defense, and stability. We have this little box that sort of tries to convey the big idea. If you're doing, even in the fight to Baghdad, the biggest box might be offense, smaller box defense, but there's still a stability box in there and you got to remember it and you got to keep it in the forefront of your mind and try to get that transition.

One last point on Panama, you know there actually was a pretty well developed plan for post-invasion Panama done by a bunch of great reserve Civil Affairs guys who had built this plan up over the course of a number of years in their summer duty down in United States Southern Command (SOUTHCOM), and of all things, no one knew it was, literally, on the shelf. So therefore it was not used, and as you note, when it was one of those good news stories, we now own Panama. The bad news was, we now owned Panama. Happily, there were a lot of Panamanian leaders around still, and it was a case of sort of lopping a lot of the bad guys off, and people weren't trying to blow us up in the aftermath of it either. So again, a lot of context there, but a very interesting footnote in history, that there was a pretty decent plan as people went back and looked at it. In fact, Dick Schultz, I think, at Tufts, at the Fletcher School, wrote a pretty good piece that described all that.

**Dr. Richard W. Stewart**

And, in fact, there was a similar plan for Iraq that my Civil Affairs unit prepared, for many years we put that together, Phases IV, V, and VI. Turning things back over to the Iraqi government, that was very carefully shelved and not paid any attention to.

**Dr. Lawrence Yates**

As you say, there was a two-year plan, or almost two years, *Blind Logic*. Which says something about the nature of the plan, but it was put together at SOUTH-COM and the problem was, once it was separated from *BLUE SPOON*, the combat plan, and the 18th Airborne was brought in, there was very little coordination.

**Audience Member**

And General Thurman was brought in.

**Dr. Lawrence Yates**

And General Thurman didn't even know about it, by his own admission. And thus the disconnects. But again, it was only Panama.

**Audience Member**

Roberto Bran from the State Department. My question is for Dr. Stewart. I'm obviously interested in your point about the interagency process, and we've been talking about it a little bit in the follow-ups here. But if we look at what happened with the Office of the Coordinator for Reconstruction and Stabilization, which was originally headed by Carlos Pasqual, and it was going to be this big expeditionary State Department ...

**Dr. Richard W. Stewart**

Unfunded by Congress.

**Audience Member**

Exactly. And it completely got gutted. It's has responsibility for planning nation building type operations, but that's it. The coordinating for planning, not even the planning. If you look at General Powell, who, while he was Secretary of State had advanced this concept of an Active Response Corps that's now moving at glacial speeds now that he's gone, and probably wasn't doing much better before ... and I don't want to discount the need for dynamic personalities in these kinds of roles, but what about structural reforms? We know what Goldwater Nichols did for the joint community. What about some kind of similar Goldwater Nichols reform act

for the interagency community? Have you thought about that? What would you think of that?

**Dr. Richard W. Stewart**

We thought about almost nothing else, it seems, at the War College last year because it was on everybody's lips. But every time you start to figure out, okay, let's get down to some specifics here, you realize that you're going to end up with a body full of dead Department of State people before anything like that is implemented. Because it goes directly against the grain of their culture. Not just them. There are other parts of the government, as well, that aren't ... just have to be sort of coaxed to cooperate on specific activities for specific agendas that they can see their role in it, rather than blindly signing up to something that they fear, perhaps justly, that the Department of Defense (DOD) will then end up calling their shots and militarize them. You can do it the Komer way, which is to subvert ... not subvert, but get inside the military as a civilian and force them to think about more civilian issues. But that's a fairly rare occurrence. It's an extremely hard thing to do. You know, how long had it taken for Joint to even begin to soak into the culture of our military? Twenty years after Goldwater Nichols, and there's still some ... some, not much ... resistance. But it's been pretty successful, I would say. So we're talking about a 20 year struggle with a lot of very political, savvy people in Washington who will die in many ditches before they let something like that happen. It will be a long fight, a bloody one.

**Audience Member**

Dr. Corum, I know it's hard to summarize a 12 year conflict in 15 minutes, but since you did so well on the 12 years, could you briefly address media relations and their importance in the Malayan conflict?

**Dr. James Corum**

That's something I plan to do a lot more work on. It is interesting, and it ties into the whole problem that the British had ignored the Chinese, not having people who spoke Chinese. The British, the initial propaganda campaign is fascinating for it's incompetence. They were coming up with pamphlets with British slogans like, "Don't be a fence sitter." Translating this very literally into Chinese. And the translation for "Don't be a fence sitter" in the literate Chinese ... of course, many Chinese couldn't read ... would look at this and wonder what kind of deep meaning this had. This term "Don't be a fence sitter" had absolutely no cultural ... it had no meaning to the Chinese at all. It's relatively ... in fact, right on up, again, into '52 ... and this is one of the many things Templer looked at.

One of the things Templer does is he brings in a new Chief of Propaganda because the government can't [inaudible] and they finally hire some educated Chinese to deal with the Chinese. I mean, you know, wonder of wonders. You have British people trying to deliver a British message that just absolutely falls flat. And up until '52, '53, the British assessment of Communist propaganda ... that's one of the reasons they're growing so quickly is that it's far superior to anything that the British are coming out with. At the same time, Young and Templer, in making their reforms, are thinking very much in how to get this across to the public because the abuses that occurred by military police in discipline, was a huge recruiter for the civilian population. You find this is standard, going way back in insurgencies. Go back to Ireland. Probably sending the Black and Tans in was the last step to pushing the Irish over to be virtually unanimous for independence in the south. So they developed a very sophisticated campaign.

Now, it's tied in ... the propaganda campaign was tied into the police intelligence system that Young created because with good intelligence, they start specifically targeting individual small groups for loud speaker broadcasts and so forth. They start doing regional things like they don't all have radios, but the one great media, even for the illiterates, is that they showed newsreels before the movies in the villages. They would come up with these brilliantly done, by '53, '54, brilliant propaganda newsreels, but they would target for specific areas and specific groups working propaganda and the media guys together. I haven't gone into this, but I think there's some really interesting ideas that can come from this, a competent Special Intelligence group working with the propaganda guys to deliver localized messages down to undermine support and so forth. The program was tremendous in bringing in a lot of amnesty people and surrenders. Of course, they target amnesty programs as again, every successful counterinsurgency campaign has got to have a program to give amnesty to bring people over, the Chui Hoi and these other programs.

As much as we don't like bringing in people who have killed our people and shot at them, it happens. Every successful campaign has that. It's interesting in looking at the original documents. If you look at the published stuff on Malaya, you get the impression Malaya is about young infantry Lieutenants out there in the jungle. That is 95% of literature. There is next to nothing on the old infantry Captain who is training the home guard. However, I happen to think that the old Captain or the retired General who is training the home guard did more to win that war than the aggressive young infantry Lieutenant who was out doing these jungle campaigns. But as military people, our own culture is we look at this military combat side of the operations and looking at police in Malaya who did all the fighting, there is ... probably 2% of what is written and published on Malaya is about the police, 98% is about the military. But 75% of the fighting was done by the police. So, you know, there's a cultural problem that we have in the way that we look at things

and I'll tell you ... hey, when I started studying this stuff, I was thinking military and thinking Army and ground combat. My thinking is changing dramatically. But your point on the media, I'm thinking that was one of the great success stories. But it started out really bad.

**Dr. Lawrence Yates**

I'm going to have to call an end to the proceedings. Thank you all very much for your presentations. Thank all of you.



## **US-Iraq Joint Operations**

(Transcript of Presentation)

### **Lieutenant Colonel Kevin Farrell—US Military Academy**

Let me point out, this is a subjective view. These are my views as one battalion commander looking at it from the perspective of where I was, East Baghdad. By training, I'm a European historian. My dissertation from Columbia is in Modern Western European History. So in no way do I pretend that today's discussion is history, rather it is a subjective experience taken over the course of one year deployed. It's also just the view from my perspective. I'm making no comments, really, at levels above me or actions or decisions made that were beyond my influence. Say there are ... kind of to put the bottom line up front, there are some excellent Iraqi battalions out there. Most of them, I would say, would not fall into that category, the ones that I saw, and the senior Iraqi leadership that I witnessed, I would not describe that way. But that doesn't mean there are not outstanding units.

A dizzying array of types of formations. I'll go through that a little bit. But when we say Iraqi Security Forces or Iraqi Army, it does not convey ... and some of you in the room, you know this far better than I, but a dizzying array is the phrase I would use.

US effort not coordinated. Now that might rankle a little bit. And by that I don't mean that there are not US agencies specifically dedicated and very competent chains of command working with the various agencies of the Iraqi security forces and the Americans ... or the Coalition Forces I should say, more accurately. But down at the user level, at least, again my experience was it was not coordinated or not coordinated as well as it could have been.

Finally I'd say the potential is great. We would all agree, I think, that having been there that this is the path to success. Getting the Iraqis to take on this fight for themselves, to stand on their own, is the long-term goal, but there are challenges that remain.

Just a quick snapshot, the old obligatory bar chart to show you the organization had been a conventional tank battalion organized with three companies, Headquarters ... we transformed. I took command in July of 2004. Right in the midst of the transformation we created out of whole cloth basically, a second infantry company, task organized. Took another infantry company from a neighboring infantry bat-

talion, 3–15 Infantry, and then had two tank battalions. But we also, now, permanently had an Engineer company, a headquarters company, and in direct support mode, effectively part of us, a forward support company.

Our MTOE strength, or modified table of organization and equipment, meaning how many we were authorized, 926 men (Figure 1). We deployed 813. Most of the time during the deployment, we were able to field about 710. So why do those numbers drop? 10% were gone throughout most of the deployment on environment morale leave, or R&R, for two weeks back home in the States. It also involved usually a week of travel. So that was part of it. Casualties, both killed in action and wounded, accounted also for the reduced strength. The reinforcements did not come as much as we would have liked. Then there were disease, non-battle injuries.

I'd point out on the bottom, you'll see that I've got some other things here. The MiTTs and the SPTTs, we've discussed these terms, the Military in Transition Teams and the Special Police Training Teams, they were there co-located on the forward operating base that I commanded and from which the battalion was based. But I had no direct formal linkage with them, other than the force of my dubious

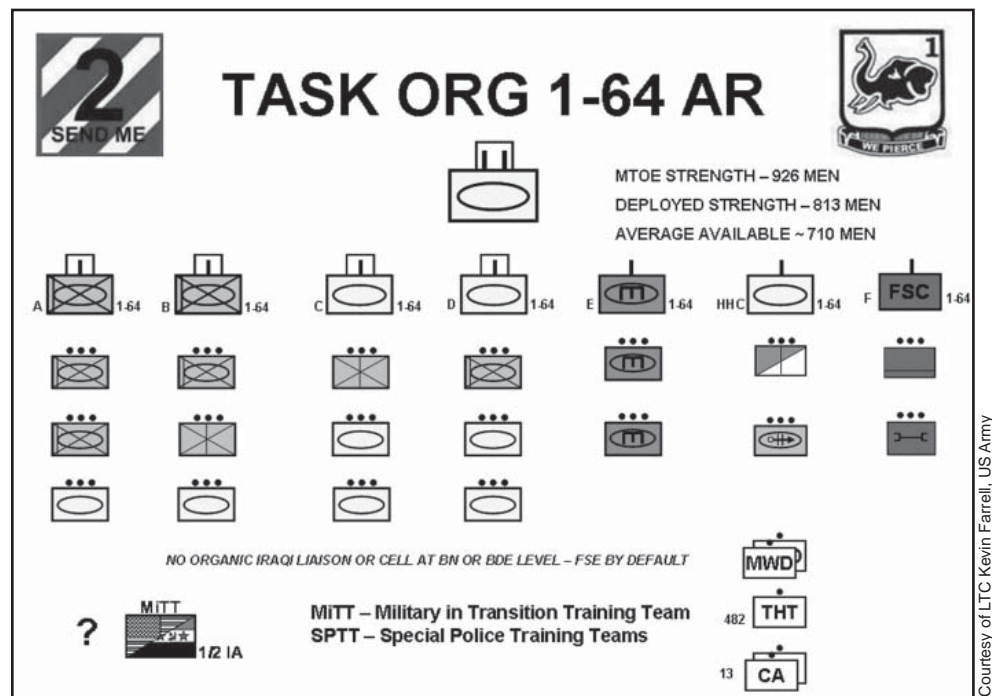

Figure 1



personality, you could say. We also had attachments, the MWD, not inverted weapons of mass destruction. Those are Military Working Dogs, Tactical Human Intelligence teams, and Civil Affairs teams that came and went. That's why I had them floating there because over the course of the year, these relationships changed.

I'd point out here that there was no organic Iraqi liaison cell at the battalion or brigade level. By default, I used the Fire Support element to cover all interactions with Iraqi forces at the beginning. By that I mean civil military operations, working with counsel, being my go-to team to work with the Iraqis. Civil Affairs teams helped, of course, and then actual commanders on the ground, myself, and my staff all worked in that. But by basic organization, there's no doctrinal position for that.

Where were we? The big map here. Obviously we've seen this great country in the news a little bit, but we were in Baghdad (Figure 2). And a lovely part of Baghdad it was. The east side of Baghdad, Tisa Nissan, New Baghdad, Baghdad Jadidah, a number of different names that it takes several months to really get it all sorted out. But I would also, just to orient you because you've heard of a lot of these places, perhaps, the Green Zone was just to our southwest. The Baghdad

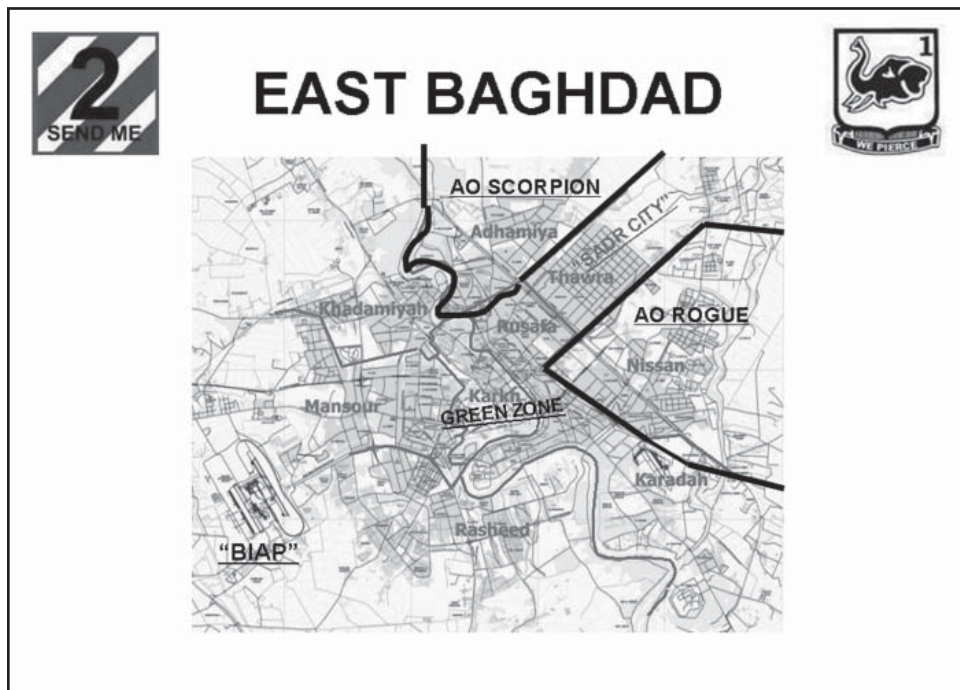
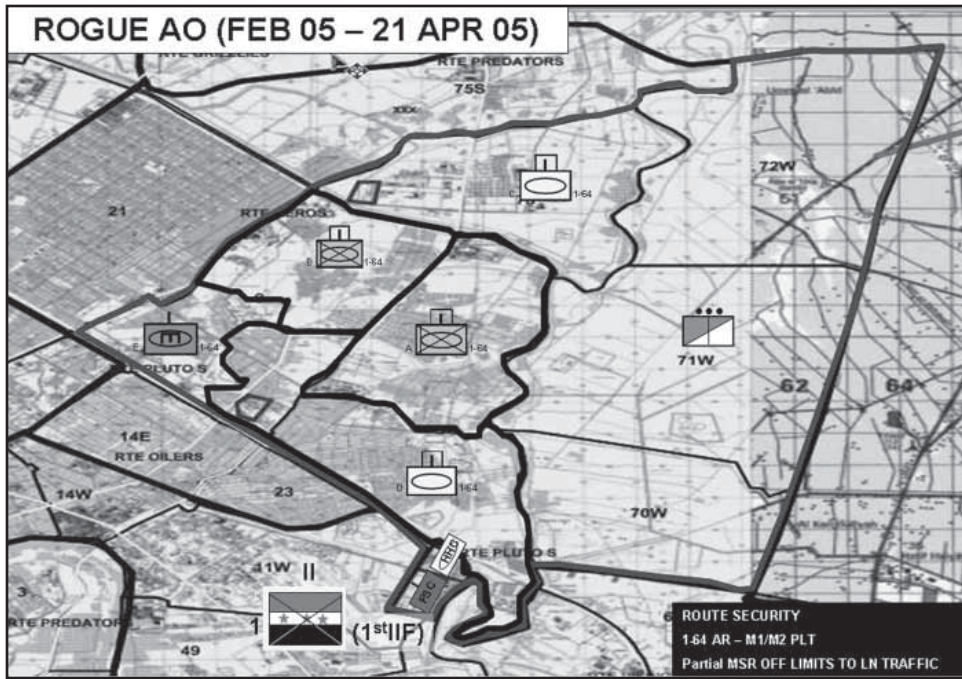

Figure 2

International Airport is quite a bit further to the west. Sadr City, it's real name is Thawra, was a major influencing area in my area of operations, but I did not conduct operations there. And then I have labeled here the Adhamiya. You might remember from the news there was that big bridge disaster where there was a stampede. Several hundred Iraqi's drowned in the river. That was Adhamiya. I never had operational control over it, but the Scorpion battalion that did, I worked with them extensively and had a permanent detachment there. I'll go into that at some length.

The way that the battalion occupied the battle space changed three times over the course of the year, and I won't go through it in any extensive detail, other than to point out that in the beginning it was an area that was quite large, but part of it was rural, most of it was urban. I'll talk through some of the specifics of the terrain. But here in the beginning there was this force, the first battalion actually is Intervention Force, didn't have a name other than that. They'd been formed in 2003. They occupied the southern half of the forward operating base where we were located. No relationship with them other than, "Hey, who are these guys?" I got to know the commander, Colonel Ali, fittingly enough as many of the Iraqis share that surname. We became close friends and developed a very effective partnership. I'll go into that at some length.

You see I divided my terrain equally (Figures 3a and 3b). I gave my companies actual space for which they were responsible. A main mission of mine was route security. I'll go through, again here, in some detail what it took. But that's how it looked the first few months. Then it changed. I picked up some additional space to the south, and also the 1st Iraqi International Force (IIF), they were fading. I knew they would be gone, and by this stage I had very little to do with them. So I had no real partnership for the next few months with any Iraqi forces, although they were passing through my battle space frequently. I'll touch on that.



Courtesy of LTC Kevin Farrell, US Army

Figure 3a

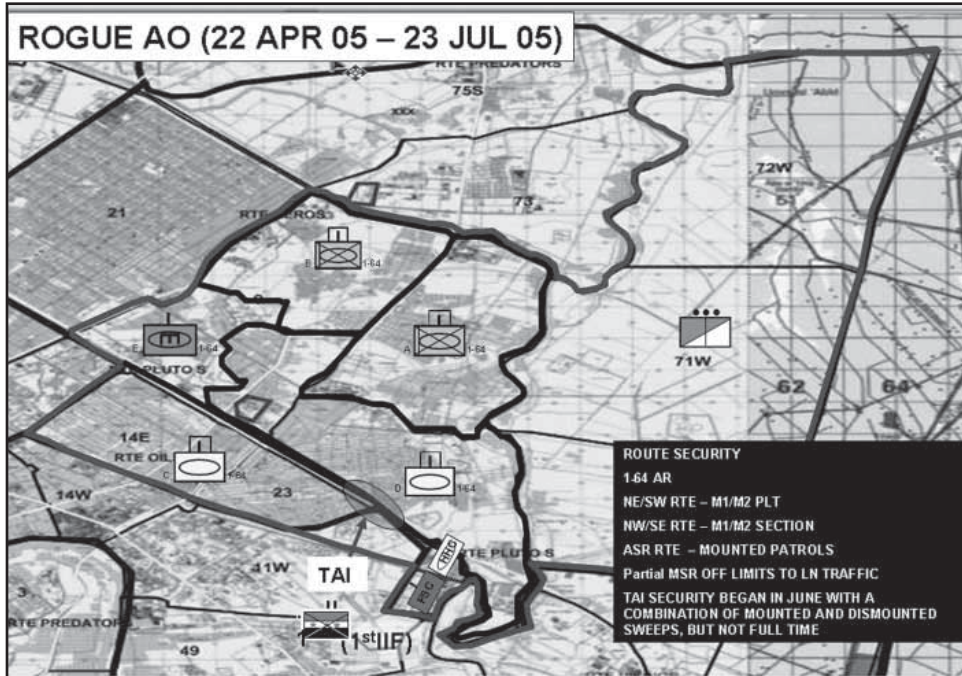

Courtesy of LTC Kevin Farrell, US Army

Figure 3b

The final portion of the deployment, the 1st IIF left completely. I had these formations known as Public Order Battalions operating in my space, but I had no operational control or formal relationship with them at any time, although they were all over. Not just these two units (Figure 4). I've singled them out, but there were a number of others. They lived there, but I had no relationship with them. Then the area I described earlier, in Adhamiya, there was the 1st Battalion of the 2d Brigade of the 6th Iraqi Army Division, which was quite good.

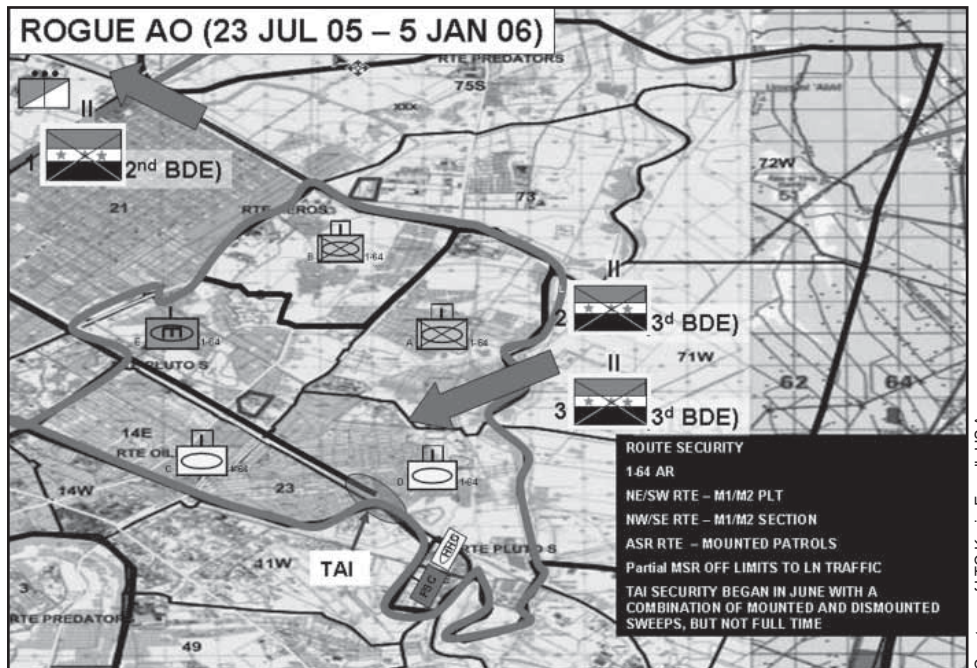

Courtesy of LTC Kevin Farrell, US Army

Figure 4

To discuss in some detail now the area of operation (Figure 5). There were three US bases. There was Bob Hope up north where the infantry battalion and the brigade was located. In the center there was Forward Operating Base (FOB) Loyalty, where the brigade headquarters, the brigade artillery battalion, the brigade support battalion were located, and a lot of the other infrastructure types. And then on the FOB I commanded, there was also co-located the 37th Cav Battalion, also the brigade support battalion, in addition to other enablers. Population of about 4,000, a small city. A minor additional duty of mine was to command this installation, as well as to run the battle space. Just an added wrinkle in there, that we touched on maybe even with the Malaysians, I had 500 third country nationals as contract labor on this FOB, most of whom had not been vetted in terms of security. There was always a great concern that the suicide bomber or those types of things ... so that was one of the things we had to do, as well, screen all of these individuals and make sure that they did not pose a threat, or were not gathering intelligence on us. The frequency of rocket attacks and border attacks, those types of things, would ebb and flow.

I'd also point out, some of you might remember the UN compound where the weapons monitoring team was located before Operation IRAQI FREEDOM, and

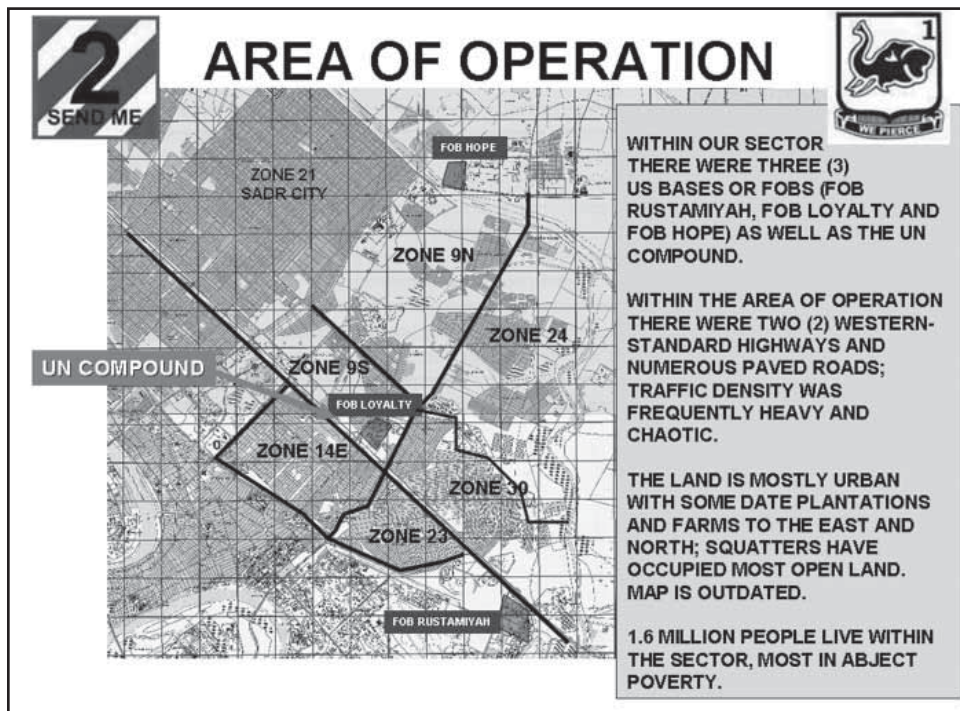

Figure 5

it was subsequently blown up in September of 2003. That was another fixed site for which I had responsibility. So I had a permanent garrison there, although it was primarily a warehouse, no UN personnel there, per se, there were several contract personnel, local nationals, working for the UN, but there was no UN mission there, and it's filled with sport utility vehicles, computers that would turn on and off. It just sat there gathering dust for several years. But it was a high sensibility site that could not afford to be let go or handed over to any nation other than US forces.

Two main highways in the area, New Baghdad Highway, north, south, west. Truly to western standards. I think they were built by the Germans, or the engineers, at least, back in the '70s in the days when oil money was flowing in. They would really be equivalent to a US standard highway. Excellent. The rest of the roads in varying states of repair or disrepair. Always the traffic was unpredictable. Frequently heavy and chaotic. Mostly urban, highly dense. About 1.6 million people, the vast majority of whom lived in abject squalor, making *Soylent Green* almost look beneficial in comparison, if you've ever seen the movie. But there were also rural areas that were quite peaceful. Date plantations, date farms out to the east.

I would also point out that the ethnic breakdown affected significantly the character of the neighborhoods (Figure 6). There was a small but affluent Christian population. They made up about 5% of the population. Streets there, you would think you were in southern California. They were clean, they were paved, they had trash cans in front of their homes that were picked up regularly. Even, in some cases, they had sprinklers. They had lawns. I mean, to see grass ... but very much a minority. Also these areas were not sources of trouble in any way. There was no insurgent activity there that I remember or could think of, and they were favorably disposed to us. The Sunni areas pocketed in different locations. Most were fairly well-to-do, although the reception toward the Americans at this stage, was somewhat cool. Many former regime elements, senior leaders, retired Iraqi general officers, former members of the government lived in these areas. No overt actions taken against us in these neighborhoods, but their disposition toward us varied from polite dislike to just non-interaction completely.

Then we had the majority being the Shiites, again, most of whom lived in just absolute poverty. In the east living in the mud huts, in other places just cramped urban conditions. Tisa Nissan was known for decades as the source of crime in Iraq. It would be kind of ... I don't want to disparage any part of the United States, but maybe the south Bronx could have a similar reputation, or some areas of the United States known for certain types of activity, and this is what characterized Tisa Nissan. A true garden spot.

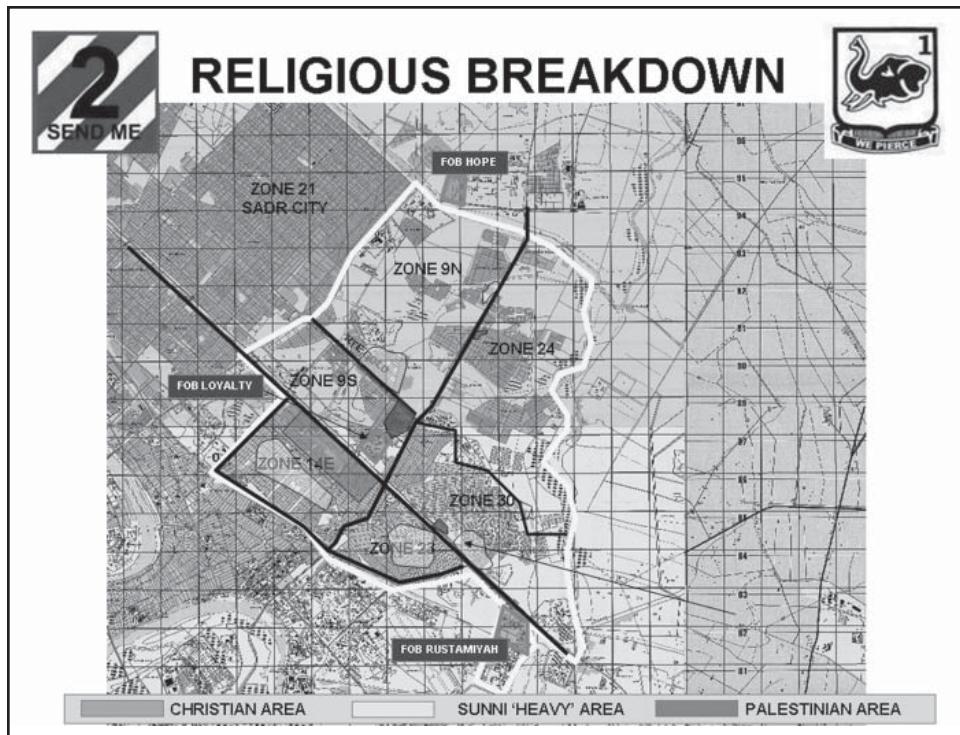

Figure 6

The last thing I would point out is we had a Palestinian group, just kind of isolated. Hated pretty much by everyone. Denied citizenship status by the Iraqis because they were seen as hold overs from the Saddam regime, and they had been afforded a very special place under Saddam Hussein for political purposes, but now they did not have citizenship. They had no country that would accept them. They had no means of employment, and no sympathy. So the first time ... not the first time, but when there was an Improvised Explosive Device (IED) that went off or an attack, everyone always said, "Oh, it's the Palestinians." Kind of round up the usual suspects type of thing.

Very briefly here (Figure 7), and I don't want to go into this. I've diluted it somewhat to make it non-classified. This very busy slide is merely to emphasize pretty much the obvious. That a number of threats exist throughout all of Iraq and all politics is local, so what we experienced is not necessarily what everyone there experiences, but the variety, whether it's criminals, terrorists, militias, or perhaps others, what do they share in common? Even if, in some cases, they despise one another, they are somewhat united in their hatred of us, and will work together toward that goal, even though they won't cooperate otherwise.

Operational overview. Again, over the course of a year, my commander's intent from division and brigade, and then what I, in turn, emphasized, changed in order of precedence, perhaps, but tried to pull out the five key tasks that guided our time there. I would focus on these, isolate, neutralize anti-Iraqi forces, develop Iraqi Security Force capability, secure key terrains, support governmental development, support economic development. None of these themes are surprising. They build, I think, with many of the previous briefings we've heard so far. So we're on good historical footing here. And again, today my purpose is to focus on this business of developing Iraqi Security Forces (ISF) capability.

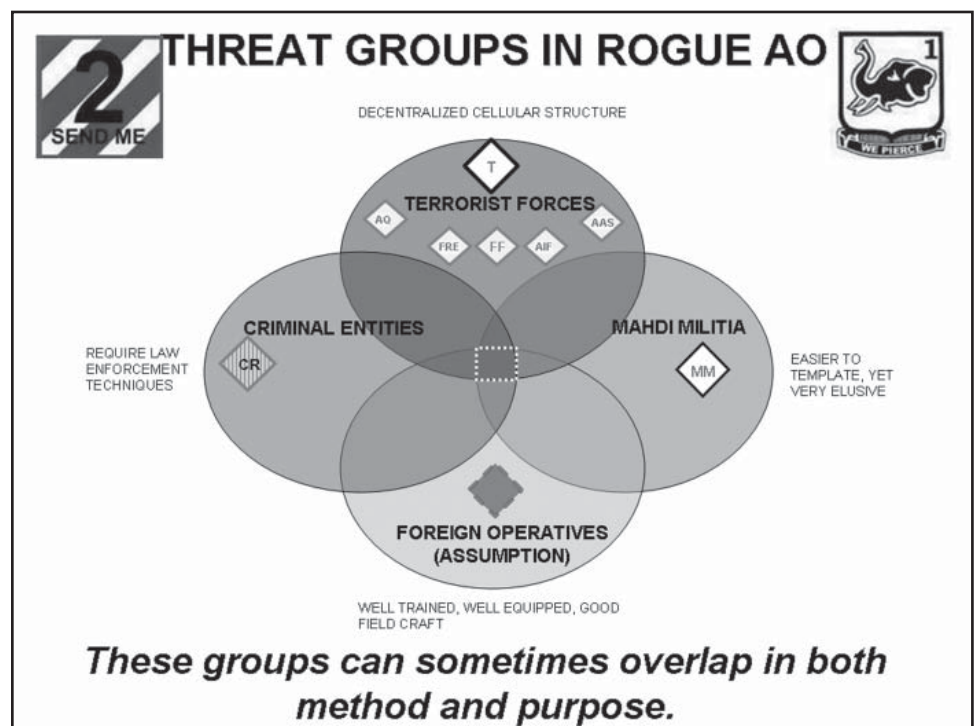



Figure 7



Now, sounds great, it briefs well, we all understand that it's the key to success. Reality is that we had quite a few things going on that made that main effort difficult to pull off because there's no dedicated force to do it that you can pull out easily, at least within my battalion. Because we averaged 18 to 21 patrols per day (Figure 8). Remember that this time of the year over there, it's getting up, routinely, above 110, sometimes up to 120 degrees. Inside a tank or a Bradley, it will get in excess of 140 degrees. You can only put soldiers in that environment for four hours, maximum, and then they're shot, really, for the next 20. That's just kind of as a backdrop. The physical limitations of what you can expect soldiers to do, sustained over the course of a year. Because no one's pulled out of the line, other than that two weeks R&R. It's not like you go on a four day pass to Saigon or the battalion is pulled off the line to refit. This is steady state, constant, and characterizes, pretty much, from what I understand, how all of our forces operate over there, which is an interesting aside, perhaps to be discussed under another venue.

I had to have the Quick Reaction Force, both tracked and wheeled, because depending on the threat and where it would occur, and the need to get there quickly, we could do different things. We'd have patrols in sector all the time. No surprise,



## TYPICAL DAY IN THE ROGUE AO

### Average of 18 patrols per day



- Security for UN Compound & FOB Rustamiyah
- 1 x M1/M2 Quick Reaction Force (QRF) PLT
- 1 x Wheeled QRF PLT
- 5 patrols in sector
  - Gather intelligence
  - Assess atmospheric
  - Attend NAC meetings
- 7 patrols dedicated to route security
  - Control NW/SE Route
  - Control ASR
- TAI Security – 4 Patrols
  - Highest historic threat area in 2BCT AO
- Route Clearance Missions with the Buffalo
- 1 DAC or NAC Meeting

***NO FORMAL ISF PARTNERSHIP!***

Courtesy of LTC Kevin Farrell, US Army

Figure 8

the best way to gain intelligence on the enemy is always being there in person, ideally dismounted, talking to the locals, the cop on the beat mentality, trying to capture the pulse of the neighborhood. Our best intelligence always came from local sources. Unfortunately, we received very little, if any, useful intelligence from on high.

Seven patrols were dedicated to route security. My main ... I hate to use the term zero defects, but the most critical day-to-mission was to protect those routes where US and Coalition forces trafficked. And the IED threat here was significant and ever present. I had the responsibility to protect the lives of all friendly forces passing through on these highways. And that took a lot of time, because if you have several thousand civilian vehicles passing a given spot per hour, to identify that one vehicle that stops, discards the explosive device, in a very short period of time, you get a sense for how daunting that task is. To have assets to cover these sites everywhere, a bit of a challenge. But, on average, it took seven patrols to do this and a number of techniques that we applied.

Fixed sites, as well, and key danger areas required constant coverage. Route clearance missions, and then finally, the ever present meeting with the District Advisory Council and the Neighborhood Advisory Council, basically local governments. Why do I lay this out in excruciating detail? Just to show the routine, day-to-day stuff. This is all what happens without even contemplating the major battalion level operation or the partnership exercise, or something to reach out and do different initiatives. This alone would tap us out. I point out no formal ISF partnership, really ever the entire year that I was there. At least that was dictated.

A laundry list here (Figure 9). The old eye chart just showing battalion level operations, by which I would define that as three or more companies over a sustained period of time, meaning a couple of days. At least a full day, involving a significant percentage of the battalion. The first one, no ISF, but everyone following that, I made sure that we had ISF involvement, even if in a modest way. Again, stating perhaps the obvious, but combined operations were always more successful when the Iraqis were involved. I'll talk through some specifics on that. I've highlighted here the elections. Use of Iraqi forces was essential to the success of the elections. The two major elections of 2005, first the Constitutional Referendum on 15 October and then the election of the national government on 15 December, I think from the division perspective, and certainly from ours, was the highlight of the deployment. One of the key reasons why they were so successful and there was so little violence, if any, that I experienced, was because of the Iraqi factor. That the Iraqis were out and they rose to the challenge and they pulled off the security mission.



## BN MISSIONS



**OFFENSIVE OPERATIONS OPERATIONS (TOA – JUL 05)**

- Operation Deep Zone (7 MAR) (*No ISF*)
- Operations Market Sweep I & II (3 – 5 MAY)
- Operations Vigilant Hook (6 – 7 MAY)
- Operation Long Rifle (10 – 20 MAY)
- Operation Overload (JUN 05)
- Operation Determined Fury (6 – 7 JUN)
- Operation Free Speech (15 JUN – present)
- Operation Dry Sweep (15 – 17 JUN)
- Operation Prairie Fire (6 – 9 JUL)
- Operation Traffic Stop (13 JUL)

Courtesy of LTC Kevin Farrell, US Army

Figure 9

Here's just a kind of a snapshot, an operation from June, Determined Fury, a great name (Figure 10). You can see we just pulled off, hit multiple targets here, another eye chart for you. But very decentralized in execution. This is the nature of the fight that I experienced. Small units, platoon, company level, fairly simultaneously or sequentially hitting different targets.

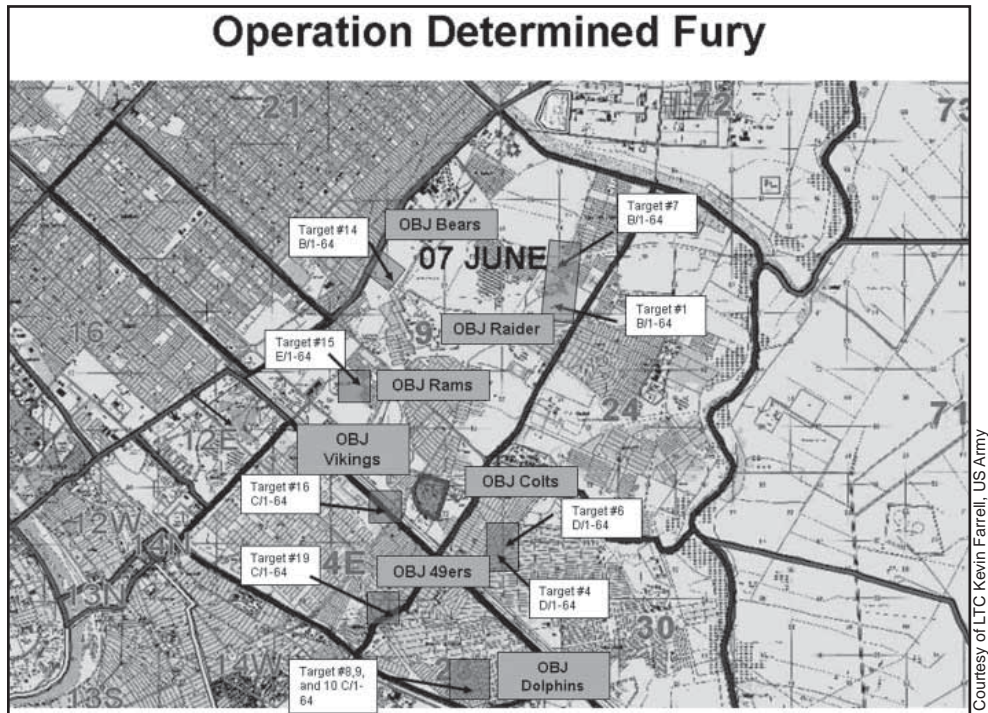
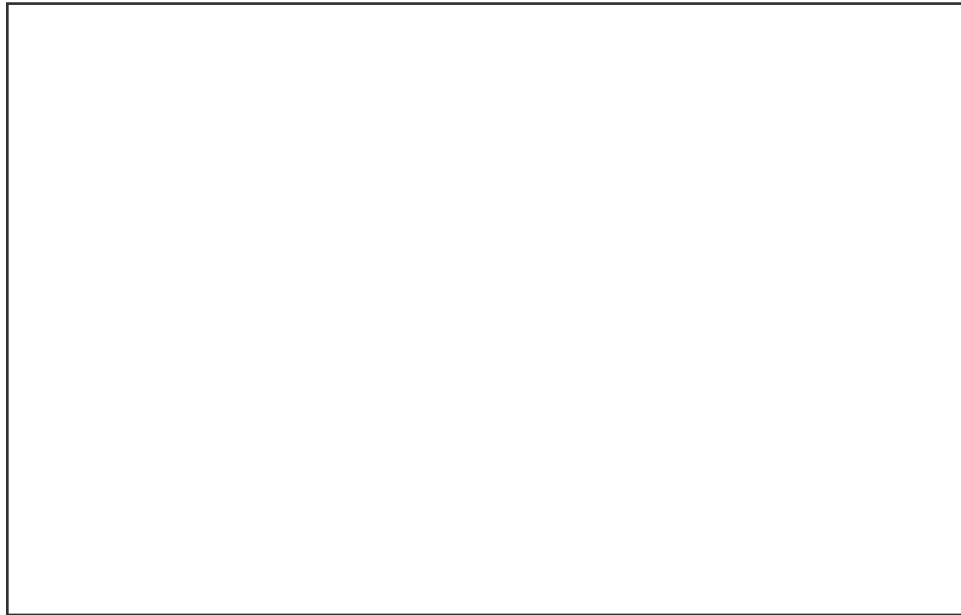

Figure 10

This involved Iraqi forces. This is an opposed shot, this isn't one that anybody has. This is a picture that I took of just your average Joe (Figure 11). The 1st IIF, you can tell by his patch. He didn't even know I was taking this. This is not ... and I'm going to dwell on it a little bit because, in many cases, this is the exception. But this characterizes the battalion, the 1st IIF. He's got the look of determination. You see the security, you see the spacing, you see the proximity to the Iraqi civilians. You see the filth and the squalor, of course. You see his finger trigger. You see that the weapon is on safe. You see that he's in proper uniform. He's wearing the flack vest properly. He has his chin strap applied. Okay, big deal. But it is a big deal because it was definitely not always the case. And what are the results? One of the best days that we had ... essentially, we uncovered a bomb making factory in one of those neighborhoods that I previously described as somewhat clean-cut and quiet. Because it was a combined operation, we capitalized on each other's strengths. The Iraqis often were uncomfortable speaking to Iraqi units on their own because of the fear of corruption, retribution, that they'd be relied upon. Are they going to want to come in, shake down the house, take something, demand a bribe? They would also be very reluctant to speak to the Americans on their own because they didn't know when we would be back, they didn't know what type of unit we were, the cultural and the linguistic barriers that existed.



Courtesy of LTC Kevin Farrell, US Army

Figure 11

How this played out, for those of you that discerned from the previous eye chart there, that's not the exact location that had been a targeted area (Figure 12). But while patrolling in the neighborhood, some locals approached our Iraqi allies and said, "Hey, there's a rental home nearby, there's rarely any activity, but one or two days a month people come and gather at night. We don't know them. We don't know who they are. You might want to go check it out." So we went ... actually the Iraqi forces led the way, and we went with them. Lo and behold, it was a rental house. It had the typical nondescript gate out front, but inside, we found a Toyota with ... you can't quite see it in that photograph, but it had the 152mm artillery rounds, eight of them, wired in the trunk, with a detonation switch on the dash board. A huge stockpile, and that's just one aspect of it, of explosives in the house, Det Cord, triggering devices, phone books, all those types of things. One example, yes, doesn't end the war. I realize that. But it highlights the benefit of working together, because had it been just Iraqis or just Americans, it would not have played out this way.

As a consequence, what we did here too, we rounded up the rental records for our area, went to all the rental agencies ... a whole thing that we'd never thought of, and said, "Okay, where are your rental properties? Who are they?" And we had conducted delivered actions in the previous list of operations I had, to go check

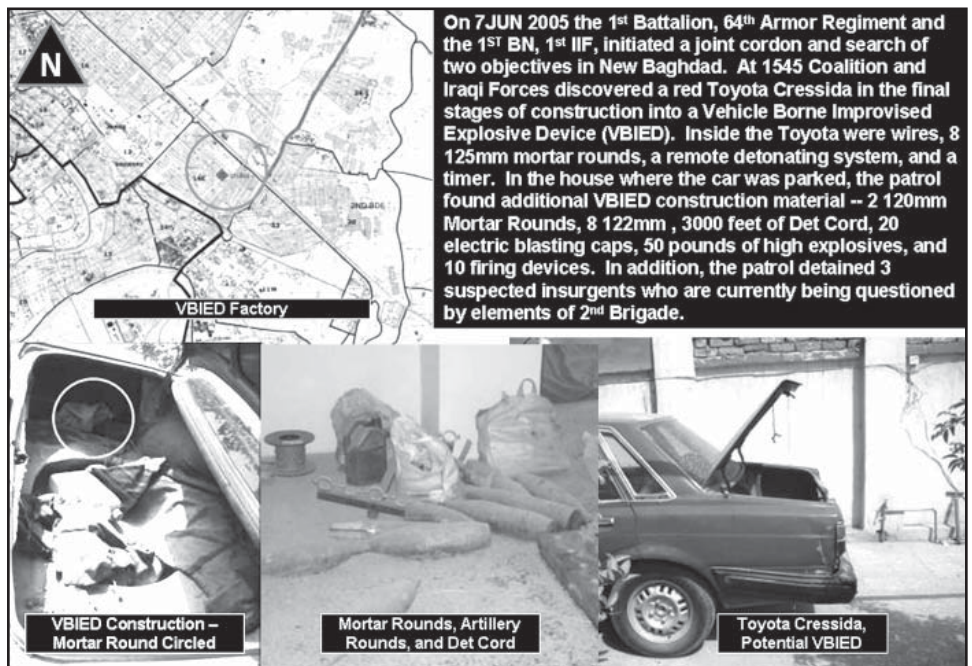



Figure 12

out these rental homes because when you think about it, what a great way for an insurgent to operate. You have rental property, you have a safe house. As long as you pay the rent, nobody's going to check anything. You're never there. You can't be easily identified. So it led to a number of additional successes. And again, it's just a great example, I think, of the combined operations working well.

So who are these partners that I worked with (Figure 13)? First, I talked about already, the 1st Battalion, 1st Iraqi Intervention Force. They were formed in 2003, somewhat murky. I have a nice plaque they gave me. I don't know the unit that actually trained them. I'm sure John McGrath will have it in his data bank to figure out who it was. But some things that I need to emphasize. It's truly a national force. Their outlook, they see themselves as part of the Iraqi Army, not south Baghdad, not Baquba, not Ramadi, not some other place. They are professional officers and Non-commissioned officers (NCO). The battalion commander, Colonel Ali, I remember I would take him sometimes with me to the District Advisory Council meeting, the neighborhood council meeting, and he would lecture them. That if they were getting too much into religion or trying to introduce too much of one political party into what should have been a municipal decision, he would also counsel other forces I'll talk about in a bit, and say, "You're not professional. You



## ISF PARTNERS



**1st BN, 1st Iraqi Intervention Force (IIF)**  
*Formed 9 APR – 4 OCT 2003*  
 Truly National Force  
 Professional Officers/NCOs  
 Mixed Religion and Ethnicity  
 Supportive of the Constitutional Process and Democracy

Combined Operations Conducted with 1-64 Armor  
**17 APR 2005 – 15 JUN 2006**

- Operations Market Sweep
- Operation Vigilant Hook
- Operation Determined Fury
- Operation Dry Sweep

*BEST ISF UNIT ENCOUNTERED  
 NEVER A FORMAL PARTNERSHIP  
 DEPLOYED OUT WEST AND DISPERSED BY USMC*

**1st BN, 1st IIF BDE**

II

1  (1st IIF)

1/1  1st IIF

2/1  1st IIF

3/1  1st IIF

4/1  1st IIF

Courtesy of LTC Kevin Farrell, US Army

Figure 13

need to be better than that.” He was inspirational. This battalion was equal to a solid American unit. They were that good.

Mixed religion and ethnicity. They had Sunnis, they had Shiite, they had Christians, which is, in my experience again, not always the case. Support of the Constitutional process and democracy, they were not hoping for a theocracy in Iraq. They were not hoping for an autocracy. They didn’t really have a stake in what the government should look like, other than it be legitimate, reflect the will of the people, and be without corruption. That opinion I gained, not just from talking to Colonel Ali, but many partnership exercises, eating at their mess hall, talking with soldiers, and the senior leadership of that battalion.

Had a great run with them, one that lasted. Again, there’s nothing official, other than we were located next to each other and happened to meet each other and talked and said, “Yeah, we’ve got nothing going on right now. The government doesn’t have us doing anything, so let’s go out.” Great results. So, as I’ve said, best ISF unit, never a formal partnership. I don’t know if that last bullet should be in green because the happy news ended when they received orders to deploy out west and they worked with the US Marine Corps forces out there, and the Marines promptly assigned them to guarding checkpoints and breaking them into three and five man detachments. So they went to kind of fixed site, growing static. As I maintained my communications with their advisors, who were very good as well, and some of them, they didn’t seem to quite have that edge. I don’t know what their status is right now.



Just what I did on summer vacation photo spread. I'll try to limit that as much as I can. But this is Colonel Ali, again, just pointing out, this is in the eastern part of my sector. Again, he's in uniform (Figure 14). He's even got the K-pot on with ... the way he has that helmet cover on, you would think he were an American. He obviously put it on wet, let it dry, all those tricks that we have. He's got the eye protection. Talking with the locals. They're about to ... I don't know if they want to give him the pigeon there. I think they're telling him about their pigeon business. But he's got his weapon at the ready, always immaculate, well maintained. Characteristic.



Courtesy of LTC Kevin Farrell, US Army

Figure 14

Here's his Executive Officer (XO), another great guy (Figure 15). Sadly, he was killed a couple of weeks after this photo was taken. Just characteristic of the type of man that he was and the type of unit that it was. We attended his memorial service at the battalion. The battalion took up a collection to provide for his widow and four children. But a great unit. In my mind, the model of what we should be doing in Iraq, and working with them.

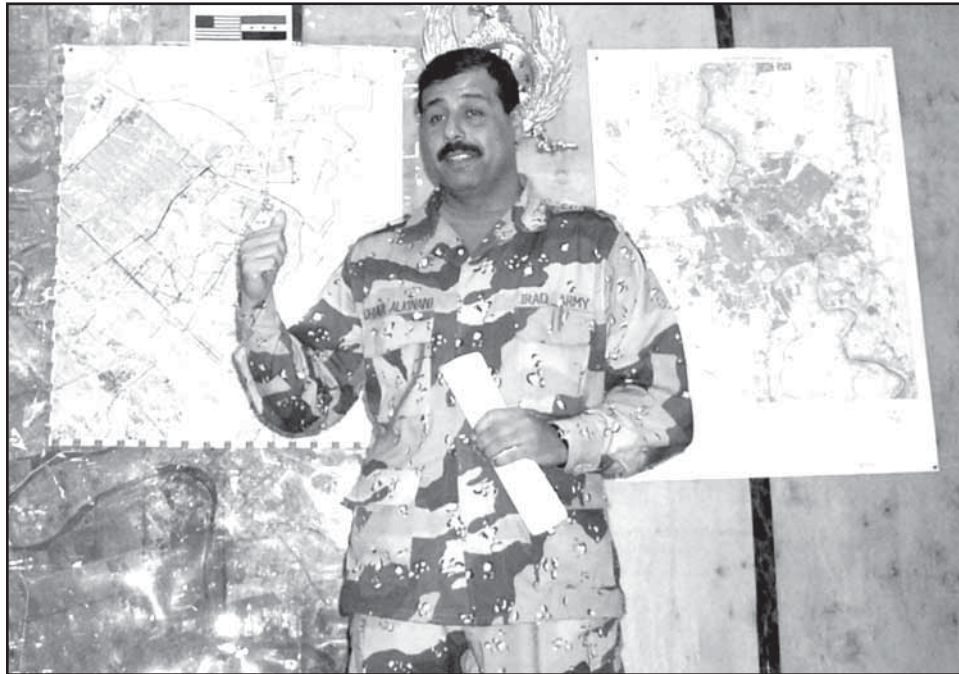



Figure 15

Moving right along, the Public Order Battalions and Public Order Brigades, quite a mixed bag (Figure 16). They appeared on the scene early on in the deployment. I remember first seeing them move into government space in the zone in March, April time frame. Very hostile at first. I remember going out to their compound just to see who they were, say hi, and of course they all reached for their trigger finger, you know, put their fingers on the trigger housing and were ready to drop us. Which doesn't always inspire confidence when working with your allies. But over time, we grew to develop a good working relationship. I want to point out, though, few professional officers, very few, if any, professional noncommissioned officers as we would understand them. It's a different organization. It is not part of the Iraqi Army, meaning it does not fall under the Ministry of Defense, but rather it falls under the Ministry of the Interior. So in our understanding, this would be a police based organization, not military based, although their roles and functions are identical, pretty much, to the ones that I described.

You see here, I say a warlord or cultic personality and militia influence. By that I mean the unit commander wielded great influence based on the strength of his personality. If he was a straight, non-corrupt, strong leader in the Western sense, as we would understand it, the unit would perform much better. Some that I saw were not that way, and the consequences were as expected.



## ISF PARTNERS



**Public Order Battalions/Brigades (POBs)**  
*Formed ~ early 2005*  
 Regional Force  
 Few Professional Officers, No Professional NCOs  
 Purely Shia (Except some senior officers)  
 Leadership Mostly Corrupt  
 Warlord or Cult of Personality – Militia Influence  
 Supportive of the Constitutional Process and Democracy...  
*as long as it promotes the right party*

2d/3d POB Operations (15 MAY – 5 JAN)  
 Operation Determined Fury  
 Operation Free Speech Operation Dry Sweep  
 Operation Prairie Fire  
 Operation Traffic Stop  
 Operation Summer Heat  
 Operations Thunderstruck I-V  
 National Referendum  
 National Elections

MITT TEAMS KEY FACTOR IN SUCCESS OR FAILURE  
 ACTIONS NOT SYNCHRONIZED WITH COALITION HIGHER HQ  
 RELIABLE IF PERSONAL RELATIONSHIP STRONG  
 NO DIRECT/PERMANENT LIAISON AT BN LEVEL  
 DESPITE LOCATION WITHIN ROGUE AO  
 PERFORMED WELL DURING NATIONAL ELECTIONS  
 RELIABILITY DOUBTFUL IN CASE OF CIVIL WAR

**Public Order Battalions**

II

2  (3<sup>d</sup> BDE)

II

3  (3<sup>d</sup> BDE)

**TASK ORGANIZATION**  
?

MINISTRY OF INTERIOR  
 FORCE; NOT ARMY AS WE  
 WOULD UNDERSTAND IT

Courtesy of LTC Kevin Farrell, US Army

Figure 16

Supportive of the constitutional process and democracy as long as it pushed kind of a Shiite theocracy into place. Maybe I'm exaggerating, but not by much. That was the read. Now that's a broad generalization, and take it at that. There were formed regime officers that knew their craft, that knew what they were doing, but they had to play in this arena, meaning they had to deal with the political ... the personal connections, the kick backs, the homage, the baggage, if you will, that came with the system under which they grew up. So if they became too close to the Americans, or if they functioned too much like American units, sometimes they would be penalized for it because it made their own bosses look bad. If they got too much press, too much praise, became too professional, as we would understand it, it would make their commanders very insecure.

Did a number of operations with them, as well. Varying success. Never had a direct partnership. I will point out, they had a MiTT team dedicated to them. Every battalion had a MiTT team dedicated to them, but the MiTT teams were not under my operational control, and were not ... it varied whether or not they were under the operational control of the brigade headquarters. So again, this is force of personality. Me, my subordinates talking to American counterparts saying, "Hey, why don't you go out with these guys?" We said, "Well, we can call them on the cell phone and we have a good relationship." I remember being told, "Don't be caught with them alone, because you know, they're some scary guys." That is one example. A friend of mine, I won't say his name here, a Lieutenant Colonel, was killed in the late summer. I believe he was targeted. Very effective MiTT advisor and was stamping out the corruption in the unit he was advising. He was out every day, as was his team, but depending on the element you're working with, that was identified and sadly, he paid for that.

So clearly, the MiTT teams, the US advisors, play a huge role in the success of these units and their subsequent development, because they do look up to us. Regardless of the type of Iraqi unit, they were impressed by American, by Allied or Coalition force, professionalism, by our fire power, the air power, and the medical support. One of the key things for them in taking part in our operations is, if they know they can get access to US medical support, their morale skyrockets. Of course, we always benefit from their cultural understanding. They could look at a scene, they could look at a house, they could tell if something didn't look right. They could tell immediately Sunni, Shiite, Christian. For many of us, we'd pick it up over time, but they would get the subtle nuances ... again, I'm saying nothing new here, but they would get subtle nuances immediately that, for an American, perhaps being years in the country, he couldn't equal.

Actions not synchronized with Coalition higher headquarters. These types of units, especially, were not tied in with the Ministry of Defense, with the Iraqi government, and in many cases, with their immediate higher headquarters. Sometimes they would get a call straight from ministry level to send a battalion some place because they had a personal connection. Their own US advisors might not know that they were moving out. The battle space for which I was responsible, they'd go plugging into it, I wouldn't know if they were coming there or not. One way that we attacked this was to insert, permanently, a team from my battalion to work with them, as much to keep tabs on them as also to continue to develop them. Couldn't sustain that the entire second half of the deployment, but it worked well. That's why I talk about no direct permanent liaison at battalion level. Even though they worked in our battle space, we just never had it.

Performed well during the national elections, reliability doubtful in case of civil war. All Shiite, very strong support for the militias, so if you had militia on militia, you could question whether they would be a neutral force. Again, these are just two units, not characteristic of everybody. As I said, a Ministry of Interior force, not part of the Army as we'd understand. Here's a great picture of them in action (Figure 17). The hidden identity. The Chevrolet Love pick up truck. What



Courtesy of LTC Kevin Farrell, US Army

Figure 17

a great name. Over here, I believe, is the Chevrolet Colorado that we provided to them by the hundreds, but their ability to maintain and sustain them was lacking. So you can see that it's already taking it's toll and they'll be scrapped for spare parts to keep the few remaining ones going. You've got ... sometimes they would mount ... and I'll show you other pictures of heavy machine guns on top. Varying uniforms. Not too bad in the discipline mode in that scene.

The final group I'll talk with in some detail is the 1st Battalion of the 2d Brigade of the 6th Iraqi Division (Figure 18). Another outstanding battalion, worked west of where I was, northwest, as I pointed out. The Scorpions.



## ISF PARTNERS



**1st BN, 2nd BDE, 6th DIV Iraqi Army 1st (1/2/6 IA DIV) "Scorpions"**

*Formed ~ early 2005*

- Regional Force
- Many Professional Officers, No Professional NCOs
- Purely Shia
- Leadership not Corrupt *at battalion level*
- Capable Commander – former prisoner of Saddam
- Supportive of the Constitutional Process and Democracy

1/2/6 IA Operations (15 MAY – 5 JAN 06)

- Pacification of Adhamiyah – Continuous Operations
- National Referendum
- National Elections

PACIFIED PREVIOUSLY *UNRULY SUNNI AREA*  
 PERMANENTLY EMBEDDED US DETACHMENT  
 STRONG BATTALION  
 HIGHLY RELIABLE *BATTALION*

1st BN, 2nd, 6th DIV

II

1  (2nd BDE)

⊗ ⊗

⊗

⊗ ⊗

⊗

⊗ ⊗

⊗

⊗ ⊗

⊗

Courtesy of LTC Kevin Farrell, US Army

Figure 18

348

The battalion commander was a guy, Colonel Ghassan (Figure 19), he'd been a prisoner of Saddam Hussein for a year. He talked about being in the Red Room. He was imprisoned, apparently, in a room that was painted red with a red light for a year, as kind of extended torture. A real character, completely dedicated to his nation. A former Chemical Officer, Major, now commanding an infantry battalion as a full colonel. Boundless energy, eager to learn, and in July, I was given the mission of taking over an advisory role to this battalion. In other words, creating a military transition team, an advisory team, out of my formation, and permanently embedding it with them. So I did that by taking my Scout platoon as the security force, and a former headquarters company commander, first Mike Dick, and then Chris Mahaffey, who did an outstanding job.

Purely Shiite force, operating in a purely Sunni area, that previously had been unruly, to put it mildly. But because they treated the people well, they did not use heavy handed tactics, that area pacified completely. Helped out, again, in all the big things. I would say very strong battalion, very highly reliable. Here he is getting the obligatory end of tour certificate, thanking him for the partnership. Can't say enough great things about this man.



Courtesy of LTC Kevin Farrell, US Army

Figure 19

Just an example of an NCO in development. That's a Delta Company First Sergeant (Figure 20). This was right after a fire fight and he is proudly sporting the captured vest that he's taken. I was walking along with the guys and all proverbial H-E- double hockey sticks breaks out. Gun fight. They take out a couple of bad guys and captured a few others. Then you can see kind of the celebratory mood afterwards. But a good day. Again, you'll see a disciplined soldier, knew his role as the First Sergeant, proud of what he's doing, proud of the unit.

Other forces encountered. The previous briefing by Dr. Corum, he talked about the police in Malaya. I haven't addressed that here formally today, but a major aspect of my role. They had, again, multiple sources of dedicated advisors, both US Military Police (MP), that did not fall under my operational control. The brigade's operational control, I'm not quite sure where they fit in the division scheme, but operating, again, within my area of operations. Their own chain of command, coordinating done strictly through force of personality, not anything direct. So with the Iraqi police, a major part of my time was spent going, meeting the police chiefs, hanging out at their police stations, and asking them to go on patrol with our forces as well.



Courtesy of LTC Kevin Farrell, US Army

Figure 20



Iraqi Special Forces would come and go through the unit. Emergency Response Units, Special Response, all types of units that would show up from somewhere else without any prior coordination. They'd do their thing, or not, and off they go. Sometimes this could be a good event, sometimes it would be a bad event. Inevitably, when they detained someone or someone was taken away at 3:00 in the morning, the locals would say, "Why did you take our guy?" I would say, "I didn't take your guy." "Well, who did?" "Well, I don't know." It created ... there was lack of unity of command there. Coalition special operations forces. There were US forces that ... I did not have the authority to turn down outside agencies from coming in, so I didn't have control of the battle space.

Why do I point these things out? Because it demonstrates the number of different units, activities, agencies, things going on day in, day out. So quality of these other forces varied from the outstanding, especially in the case of the Special Operations Forces, the Iraqi ones, to little more than thugs. Maybe hit squads, God knows what else they were doing. But it's all going on, and pretty much beyond my control or even influence.

Typical transport vehicle, a converted truck (Figure 21). They're getting ready to go out on a mission here. This is IIF. You can see they've added some ballistic plates to the sides, welded a small piece to the front. Weapon up top.



Courtesy of LTC Kevin Farrell, US Army

Figure 21

This is an example, nice photo just showing the mixed bag of units that we might be operating with (Figure 22). This guy's face is kind of ... very enthusiastic. Well, won't go into it.



Courtesy of LTC Kevin Farrell, US Army

Figure 22

This is the day of the elections. Typical. This is higher leadership from, again, one of these other organizations showing up at the 15 December elections. Don't really know who they are. It also captures very nicely the typical street scene outside ... well anywhere in Baghdad. But you've got the two guys in this new uniform I didn't recognize (Figure 23).



Courtesy of LTC Kevin Farrell, US Army

Figure 23

Public Order battalion vehicle here. Also on the day of the elections. You've got the gun shield (Figure 24).



Courtesy of LTC Kevin Farrell, US Army

Figure 24

This picture, although I asked the kid to think I was taking it for him, I would really draw your attention to the paraphernalia you see inside the vehicle (Figure 25). I don't know if anybody recognizes the face of this guy, but that's Muqtada al-Sadir. Not quite visible in this photo, another one, but there's a burning Humvee, US up-armored Humvee, in the background. Afterwards, you say, "Hey, good allies and friends, why do you have your vehicles adorned with posters showing anti-US stuff?" And they'd say, "Oh, some kids put it there. We don't know who." But it just shows the influence of the militias in many of these units, which poses a challenge.



Figure 25

So what, then, are my observations? Combined operations certainly the most effective. I gave you one example, and if time permits or anyone's interested, I could give you many, many additional. Our greatest successes against the enemy, and also turning corners with attitudes of locals, always involved combined operations.

The Iraqis, I can't point this out enough, they are eager to work with us. The more they work with us, the more they want to work with us because they have

great respect, once again, for our professionalism, for our fire power, our discipline, and our example. They look at us as being the standard, the model, of what an Army can be and should be. So they take great pride in that in close working. And they want access to our medical and logistical support. And we, of course, benefit, as I said earlier, from their cultural and linguistic knowledge, which we'll never match.

The personal sustained relationship is essential. This has come up a number of times in the historical briefings so far. But, to do the goat grab, as we used to refer to it, to eat the ... to eat with the raw hands at the long tables, in their style, smoking the cigarettes, taking, unfortunately, the hours of time that it took to build that personal relationship, to do the eye-to-eye contact, they wanted to know you as a man, to know where you stood, and to build that personal relationship and know that you could be counted upon.

Just as an aside, there was a case where one of the Public Order battalions was off on an operation, they had not informed their US advisors, and no one in the US chain of command knew. I got the call from a friend of mine, the battalion commander, and said, "We're getting creamed." They had walked into an ambush. They already had suffered four men killed, several vehicles destroyed, and others wounded. I called my brigade commander, Colonel Joe Disalvo, and he called it up to division. I believe he ... I don't know if he spoke with you sir, General O'Neill, or to General Webster, the Commanding General (CG), but was able to flex aviation assets, decimated the attacking force. What this did for our relationship was huge, because now this Iraqi unit knew that the Desert Rogues could be counted upon ... even though they did something that they probably shouldn't have. They didn't take ... planning, as we discussed earlier, isn't something they quite mastered. The deliberate planning process, it varies from unit to unit, but because of this incident, and it basically saved many lives, boy, our relationship was cemented. That call would have never come to me, I don't believe, had we not spent the time investing, knowing, speaking frankly. It really paved the way for a great relationship.

Lack of equipment, clearly an issue. I don't know that equipment in itself is the panacea to all the problems they face. One of the discussion points earlier was the transition in Vietnam from M1-carbines to the M-16s. One thing that the Iraqis always want, they want the up-armored Humvees, they want M-4s, the carbines. They want cutting edge ... I call them gadgets, or whatever we have. That is an issue, but I think, more important than that, is the basic leadership and cohesion and training that goes into the units, because they don't need the high tech stuff to defeat what is, essentially, a low tech enemy, and build professionalism. But they

do face a very real problem of sustaining their force. Even if it's just pick up trucks, the fuel for the pick up trucks, we buy the fuel for the Iraqi Army, which I found ... at least in my ... I was somewhat shocked by that, that I think the third largest oil reserves in the world.

Corruption rampant. What do I mean by that? Corruption is one of these terms that can mean many things to many people. There was a tradition in the Iraqi Army that every time a soldier wanted to go on leave, he would, of course, pay his commander to allow him to go on leave. So this a great source of enrichment for senior officers. Does it still happen? Oh no, no. Well, I think it does in many cases. And that's kind of a minor aspect to it. Much more serious is deliberate pilfering of money dedicated for other things. So without going into specific units, oh, they're all corrupt or they're not, I would say that corruption, as understood in the Western sense, is a huge problem. My perception there, though, is that for the Iraqi mind set, the first responsibility of the father, of the head of the household, is to provide for his family, regardless of his position. So he is not doing his duty if he doesn't take that cut, whatever the source of the money is. So how we use corruption and what it means, a long term challenge, but it's real.

Coalition and Iraqi change of command not unified. I touched on that earlier, just meaning that the synchronization of efforts from their chain of command, our chain of command, and then our own internal chain of command, Special Operations chain of command, Multi-National Security Transition Command – Iraq, (MNSTC-I) chain of command, the tactical chain of command. And then similar challenges within the Iraqis, the ministries and then the subordinate units within them. It's a dizzying array, once again, to overuse that.

Not the main effort, Combat Infantryman Badges (CIB) for everyone mentality, but it must be. I'm trying to maybe wake you up by now, shock you with the last shocking comment. What do I mean by CIBs for everyone? Every aspiring commander wants to be in that key job that's going to lead to the next higher rank. So do you want to be part of an advisory team out in the Anbar Province, or do you want to be the battalion S-3 of 1st of the 502d? Well, of course you want to be the S-3 of the 1st of the 502d. Do you want to be the battalion commander with the battalion colors, or do you want to be a detachment leader somewhere else? Our Army, institutionally, and I think like most, is built toward wanting to be these tactical units. What types of missions do you want to do? We want to do the big sweep. We want D-Day. We want that encirclement and to defeat the enemy in detail. Boy, teaching them about basic leadership, showing up for formations on time, that's not quite as glamorous. And that's really the shorthand. CIBs for everyone. I mean, there are no CIBs in that latter example, right?

I'm over stating it, really just to get the attention. Because we all recognize the importance of developing and mentoring the Iraqi Security Forces, because that's the way out. I know that it was the emphasis while we were there. It was thought to be the emphasis prior to our deployment, while we were training, and I know it's the emphasis now. But how we carry it out is still a difficult thing. And culturally, we need to understand, again, referring to the Malayan example, I think that getting the Iraqi forces up to speed is the long term path to success.

I've got more that I could say, but I'd rather, at this point, open it up for questions. Thank you.





## **Day 2, Lunchtime Presentation Question and Answers**

(Transcript of Presentation)

### **Audience Member**

Kevin, I was wondering if I might get you to elaborate, just a little, on what you talked about with respect to the advisor or mentor relationships. I suppose the best way for me to isolate that would be to ask for some comparison, perhaps. Thinking back to what I talked about yesterday, in regard to a couple of historical cases, it was considered very important the quality of those personal relationships. You might say the thinking was the man inside the uniform is much more important than the uniform. And that in order for this to really work, they couldn't think of, say, Lieutenant Colonel's as interchangeable parts. It so much depended on how that one individual who had the charisma or the personal qualities, or perhaps the cultural adaptability to relate and bond with folks. That produced effective training relationships and better units.

### **LTC Kevin Farrell**

I couldn't agree more, and I think you said it far better than I could. The reality is that the second half of my tour there especially, my main effort, personally, in addition to leading the battalion or whatever, was to go out, spend time with the known leaders of these units that I could rely upon, and further cement that relationship. The information that came out of that played out a variety of ways. I mean, I would learn the struggles they faced with their own challenges. Who got fired and why he really got fired. What their plans were. I mean, they would confide, "Well, really I'd like to go to the United States. Can you help me? I'd rather get out of here." I was like, "Wait a second, you're a full Colonel, you've got this battalion command." Just getting to know them on that level played out in many other ways, and how was that important when we would be hit by an IED or we wanted to conduct a mission, I would be able to turn to this individual and no longer do the case like we did in the beginning, like show up five minutes before, "Okay, we're going," because we couldn't trust to tell them anything. Give them a little more information about upcoming missions and know that we could rely upon them.

Another thing, just traveling with them in their own vehicles, or having them travel with you in their vehicles, we got ... of course, we'd always travel in M-1114's—up-armored Humvees—or tanks, or Bradleys. And the thought of traveling an extended period not in such a vehicle would be unsettling. Of course, they had their little, either the Love pick up trucks or the Toyotas, so it's quite an adventure hopping in the front seat with a Colonel that insists driving himself, and you've

got the guys hanging out the door, you know, with the guns everywhere. I mean it's a memorable experience. Something I'd rather not do any time soon. But those types of things are essential to build the long-term relationships. Because of that, though, and I really need to give credit to the outstanding Captains that worked for me, Mike Dick and Chris Mahaffey, working with the 1st of the 2d of the 6th Iraqi Division, living with them 24/7, being there, kind of in this outpost. Going on every mission. That commander knew that they were there and that they could be relied upon. And it's a bond.

Now, the challenge is when it comes time for us to leave. Because it takes ... it really takes months to build this. It probably takes a couple months, unless you're dedicated to this unit when you first arrived, even realized that they're there and build that partnership, but they know you're going home. As much as you tell them, "Hey, the guy that follows me ..." in my case Mark Pertolini, "he's ten times better than we are." That will only go so far because they need to build that personal relationship. That is the strength. Just like you said, it's the man, not the uniform. They want to know your family, they want to know your background, your interests. It just takes a long time to develop that. But through that, we can also, then, break into the themes of professionalism, what's the right way to train your Army, what's the role of the noncommissioned officer? One of the biggest challenges that I think they have to understand, the concept of a professional non-commissioned officer corps. It's only ... I think, culturally, we as Americans are disinclined, especially those on the fast track ... you know, whatever you will, the Type A ... what are the facts? What's the mission? Okay, let's go. It just does not play well. You have to be willing to drink the chai, the tea. They have chai there too, sir. And sit in the smoke filled room and spend hours, seemingly, talking about nothing. Or even the silence.

#### **Audience Member**

Captain Gregory, Fort Riley. What was the effectiveness of using the fire support element in a Civil Affairs role?

#### **LTC Kevin Farrell**

Great question. It depends on the quality of the team that's there, because by training, at least in my experience, your fire supporters don't have any additional background in civil military operations, working with indigenous forces, or dealing with money and accounts for building projects than anybody else in the battalion. I was blessed with a very sharp team. The cycle switched, I had two different Captains and a number of supporting players. It worked out very well. Now I do not mean to understate by any stretch the role of the Civil Affairs detachment that we joined. There was overlap from the first team that we had, great guy, New York

City patrolman. Had 20 years on the force. Great New York accent. Tough as nails. Not threatened by anything. Understood how big city life is played. A tremendous asset. But we went through several iterations and most of the Civil Affairs teams I had, until I lost them all, were good. So the fire support element was my default mechanism to provide oversight of the Civil Affairs teams, whatever attachments that would come and go, kind of to be that internal continuity for the battalion because when we switched out with the successor battalion that replaced us, I didn't have a Civil Affairs team to hand off. But the continuity was carried on by the fire support element. That was one way to do it. I don't know if it's the doctrinal solution these days, and different commanders responded differently. That's just how I chose to do it. A large part of it was the excellent officers and noncommissioned officers and soldiers that I had in my fire support element.

### **Audience Member**

You talked about how important it was to build these personal relationships. Could you give me a rough break down of how much of your time was spent dealing with combat issues and how much of your time was dealing with building these personal relationships?

### **LTC Kevin Farrell**

That's a great question. Rule of thumb, we averaged one attack a day. Some days we'd have two or three attacks, some days we would have none. If it was a fatal attack or a significant attack, of course I would be on the scene. So that occupied a good percentage of my operational time. I personally was off the FOB six days out of seven, and usually the seventh day I would go out for some purpose as well. Just to patrol and to be with my unit. Now, incorporated in that, I would hit the various units or the local government, if you will, two or three days a week. You would count on a visit with, whether it's an Iraqi officer unit or the governmental agency, you're not going in for a five minute, "Hi, how you doing? Everything good? Okay," we're on our way. Then the police as well. Your visits would be one to three hours to have anything to do. Now, that's on top of the parade of individuals that wanted to come to see you at the FOB, so they wouldn't be seen in front of their local neighborhood guys. You quickly had to sort out and make sure that only the higher level individuals ... because otherwise, all your time would be taken up as a commander, and also subordinate commanders, by the parade of visitors. So in answer to a very good question, part of it ... it overlaps. I mean operational concerns, going out, being there with units on missions, with my subordinate elements or C-2ing a larger mission, 30 to 40% of the time. And then 30 to 40% of the time maybe this other stuff, building relationships. But of course, there's some overlap. And then wanting to bring them along on ... or travel with them on operations of their own.

**Audience Member**

Real quick. What you described was kind of a saw tooth, where you build up a relationship, you go away, and somebody else comes and takes your place. The real question is, do we have a trend line going up and are we going to finally get to the point where we have a good ally and he trusts Americans because they're basically good guys and good units, or is it always going to be just a level ... a saw tooth?

**LTC Kevin Farrell**

That's a great question. I'd like to say ... I know in my case, personally, the commander that ... the unit that replaced me, Mark Pertolini, close friend of mine, brilliant guy, certainly would do that. Embraced the mission and I was very deliberate in taking him around to introduce him to all of the key players as I understood it. I'm still in touch with him now, and I know he's continuing that. Systemically though, I don't know ... or culturally. I don't know if that's the case across our Army. I don't know how many of our operations career fields leadership is comfortable doing that type of thing. So I'd say, in general, yes. But I don't know if it's thought of deliberately as a policy to build these relationships. So I think it's improving, but I think the saw tooth element of it is definitely going to be there. Especially as our footprint shrinks or we pull out different areas and what missions we have going on.

**Audience Member**

Can I follow up on that? Can I ask what kinds of things you saw units or commanders do that made that transition better or worse? Any general observations?

**LTC Kevin Farrell**

Yes, sir. Without using names or units individual, watching the transfer of authority (TOA) in different units, there were some commanders coming in that said, "I don't do meetings. These guys are a waste of my time. Don't bother taking me there." Also, when advising, "Don't go down that road, it's not a good idea to take the MSR," and then a Sergeant Major loses his leg or something, it's like, it would have been well, perhaps to listen a little bit to the unit that's been here a year. That's one hypothetical example. And then on the other hand, you have cases where they actually take it to the next step and pick up very quickly. Another individual I saw was very eager and found new sources, even during the TOA because he's looking at it with a fresh set of eyes. "Yeah, we know this neighborhood." He's like, "Hey, you want ... let's stop." Say, "Okay, we'll stop and talk." And then turns out he's a retired three star and has significant influence in that neighborhood going out. I think a positive and an important aspect to that turn over is the freshness. Because quite frankly, by the end of the year, you know, 300 plus patrols or whatever,

you've had enough. In one of the previous briefings there was a discussion of tour lengths and what's the right time and how long should we be there. But I think that without any significant breaks, other than that two week R&R period, by the end of your cycle, you're like, "Okay, okay." It's very hard to be open to new ideas and expending the energy to develop new friendships.



## **The Alliance Transformed: US-Colombian Security Cooperation, 1950-1960<sup>1</sup>**

**Dr. Bradley Lynn Coleman<sup>2</sup>—US Department of State**

The Cold War transformed the Colombian-American conventional defense partnership into an internal security alliance. During World War II, the two countries came together to defend the Americas. Colombian and US officials turned wartime defense measures into peacetime institutions after 1945. Then, in 1951, Colombian ground and naval forces joined the US-led United Nations (UN) Command in Korea. The Korean War combat partnership exemplified bilateral conventional security cooperation. Yet during the mid-1950s Colombia and the United States gradually shed traditional defense projects. Instead, officials began using US security assistance to promote Colombian domestic tranquility. Lieutenant General Gustavo Rojas Pinilla, Colombian President from 1953 to 1957, converted the Colombian military into a state-building instrument. US security assistance followed the changing needs of the Colombian armed forces. Also, the two countries considered Moscow's new approach to the Cold War, which emphasized subversive techniques, a major threat to hemispheric security. The United States and its allies needed to adapt to this challenge. Finally, in 1959, when Colombia returned to civilian rule, President Alberto Lleras Camargo requested a reappraisal of bilateral security relations. The Dwight D. Eisenhower administration responded by sending a special US survey team to South America to examine Colombia's internal security situation. The group's final report, Washington's heightened appreciation for Latin American insecurity following the 1959 Cuban Revolution, and some intense Colombian lobbying further changed US-Colombian relations. By December 1960 the two countries had formed the basis of the modern Colombian-American internal security alliance.

American involvement in Bogotá's ongoing campaign against narco-traffickers, leftist insurgents, and right-wing paramilitaries has spawned a lively debate. Regrettably, that discussion has been conducted in an ahistorical fashion that leaves one with the impression that Colombian-American collaboration is a recent occurrence. In fact, the Colombian-American military affiliation began during World War II, and the modern internal security partnership started in the 1950s. Overall, scholars have devoted little attention to the history of US-Colombian security relations. The complexity of the Colombian experience, its apparent inconsistency with broader trends in Latin American history, and the relative scarcity of Colombian archives sources covering the 1950s discourage many researchers. Those few English-language historians who have studied the period concentrate on key

events at the beginning and end of the decade. Russell Ramsey, Mark Danley, and I have published articles on Colombia's contribution to the UN Command in Korea.<sup>3</sup> Dennis Rempe's ground breaking research covers the important developments after 1958.<sup>4</sup> As for Colombian literature, talented academics have concentrated on economic, political, and social questions to the detriment of Colombian military history and foreign relations. The relatively minor role the Colombian military has played in the nation's political affairs, compared to the armed forces of other Latin American republics, contributes to its lack of appeal as a scholarly subject.<sup>5</sup> Those Spanish-language accounts that have been published focus on Colombian military figures, such as General Rojas Pinilla, or Colombia's military contribution to UN operations in Korea and the Middle East.<sup>6</sup>

Addressing these scholarly deficiencies, bridging the gap between the Korean War and Lleras's overture, this paper examines the transformation of the US-Colombian security relationship between 1950 and 1960. In doing so, it emphasizes the chronically neglected era of Colombian military rule (1953-1957), an important period in the bilateral security relationship. The paper begins with a brief survey of bilateral security relations through the Korean War. It then examines the accomplishments and shortcomings of Colombian military government; shows how Colombian and American officers adapted their bilateral partnership to promote the Colombian military's state-building effort; and relates these changes to developments in 1959 and 1960 that converted the alliance into a full-fledged internal security partnership. It finds that US-Colombian relations between 1953 and 1957 prepared both countries for the shift in direction that occurred after 1959.

The Colombian-American relationship began before World War II, produced a burst of conflict, but also revealed the possibility for successful collaboration. After decades of tense bilateral relations resulting from the separation of Panama, the Western Hemisphere's leading democracies, Colombia and the United States, partnered to protect the Western Hemisphere from overseas aggression during World War II. In 1938 Colombian President Eduardo Santos, wanting to link Colombian-American security interests, asked the Franklin D. Roosevelt administration to send military advisers to Colombia. Soon thereafter, US and Colombian representatives signed military mission contracts. The agreements allowed Colombian authorities to determine the composition and focus of the US teams, which arrived in Colombia in January 1939. In the years thereafter, the US advisers helped Colombians improve their air, ground, and naval in the techniques of modern warfare. Also during World War II, Colombian officers attended US service schools and the republic acquired some US military equipment through the Lend-Lease program. US and Colombian agents undertook counterespionage activities; the United States operated a small seaplane refueling station in Colombia; and the



two countries conducted combined operations in the western Caribbean. In 1944 Colombian officials even expressed some interest in joining the overseas fighting coalition. US officers, however, actively discouraged small-country contribution to the World War II fighting coalition. Only Brazil and Mexico, Latin America's largest countries, fought abroad. Although Colombia contributed less to the Allied victory than some other Latin American republics, Colombian-American cooperation promoted hemispheric solidarity, inter-American military readiness, and regional stability. Colombia and the United States, in turn, established important diplomatic, military, and economic linkages during World War II.

The two countries carried important institutions and relationships into the postwar period. In September 1945 military officers gathered in Bogotá to discuss postwar bilateral military cooperation. The representatives agreed to build Colombian conventional forces, cooperate in hemisphere defense, and collaborate in collective security operations. Officials expressed high expectations for postwar military relations. The pace of Colombian-American cooperation immediately after World War II did not match these lofty aspirations. Still, the US and Colombian armed forces remained connected in mutually beneficial ways. The US mission continued to work in Colombia and Colombian servicemen enrolled in US service schools. The South American republic also received some additional US military equipment. In the United States, the partnership assumed heightened significance as the Cold War escalated. Yet in Colombia, the partnership received relatively little attention. Instead, the rising social, political, cultural, religious, and economic convulsion, known as *la Violencia*, dominated the country's attention. The country's domestic political turmoil, Ambassador John Cooper Wiley observed, "overshadowed" its foreign military relations.<sup>7</sup>

*La Violencia*, which claimed 200,000 lives from 1946 to 1958, began as a political controversy during World War II. In 1946 these political disputes split the ruling Liberal Party and gave rise to the first Conservative administration since 1930. Victorious at the ballot box, Conservatives inherited the vast spoils system connected to the Colombian presidency. Fighting quickly erupted as Conservative officials displaced their Liberal officeholders. Armed bands of Liberal guerrillas formed in the countryside to resist the new government. Conservative militias soon appeared to combat Liberal forces. Then, in April 1948, the assassination of popular Liberal Party chief Jorge Eliécer Gaitán touched off nation-wide urban rioting. Conservative President Marino Ospina Pérez responded by imposing a nation-wide state of siege. While military and police forces generally controlled population centers, rural fighting accelerated, subsuming economic, cultural, religious, and political themes. In 1950 Conservative firebrand Laureano Gómez, uncontested,

won the Colombian presidency. Inaugurated in August, President Gómez, ruling as a virtual partisan dictator, promised to restore domestic order.

During his first weeks in office, President Gómez decided to send combat forces to Korea. Colombia's devotion to collective security predated the Korean War, beginning with Simón Bolívar's drive for a Pan American federation in 1826. At the 1945 San Francisco Conference, Colombian diplomats played a key role in drafting the UN charter, and Colombia's post-1945 military planning accounted for possible action with a UN security force.<sup>8</sup> For Colombian decision makers, UN inaction in the face of North Korean aggression would damage the organization's credibility. As an active UN member, Colombia had a certain obligation to support UN security operations. By 1950 Colombia had also forged a close relationship with the United States, an alliance based on compatible values, shared opportunities, and geographic proximity. Dispatching troops to Korea, Colombia proved itself a dependable American ally.<sup>9</sup> In this regard, Gómez correctly figured that a military contribution to the UN Command would create conditions favorable for future US-Colombian cooperation, even though US aid for Colombia did not enter into the Korean War discussions.

Internal variables also shaped Bogotá's decision to fight in Korea. In 1950 political and social upheaval in Colombia had propelled Gómez to the Colombian presidency. A devout Catholic and passionate anticommunist, Gómez linked Colombia's domestic affliction to an international communist conspiracy. He also had keen sense of Korea's strategic importance. The South American republic could actively participate in the fight against the "universal enemy" by joining the UN Command.<sup>10</sup> Additionally, Gómez might have calculated that an overseas expeditionary force would serve as a source of national unity during *la Violencia*, much as the border dispute with Peru had in the early 1930s, another period of domestic disorder. A host of internal and external factors therefore converged to bring Colombian soldiers to the battlefield in Korea.<sup>11</sup> Among the Latin American republics, Colombia alone made a military contribution to the UN effort.

In Korea, Colombian and American servicemen converted their hemispheric defense partnership into a fighting alliance, with important long-term consequences. A Colombian frigate and infantry battalion joined the US-led UN Command in 1951. During the war, three Colombian frigates engaged in blockade, escort, search and rescue, bombardment, and intelligence gathering duties with the UN armada. While just one ship in a massive international navy, the Colombian ship performed superbly. On the peninsula, Colombian and American servicemen formed an operational partnership in Korea, Colombian forces embedded with larger US units. Fighting with the 21st US Infantry Regiment, 24th US Infantry Division, during

the Kumsong offensive in 1951, Colombian soldiers demonstrated their aptitude for war. When US planners transferred the 24th US Infantry Division to Japan, the Colombia Battalion joined the 31st US Infantry Regiment, 7th US Infantry Division. During 1952 and early 1953 the two units defended the UN front as armistice negotiations sputtered forward; a November 1952 US Joint Chiefs of Staff report concluded that the Colombian soldiers had accumulated an “excellent record” in Korea.<sup>12</sup> Then, in March 1953, the battalion suffered a major setback on Old Baldy. But the defeat did not alter the outcome of the war, which ended in July.

As for the bilateral relationship in Korea, the 31st US Infantry Regiment commander believed the bond between US and Colombian forces stronger than US ties to any other small-nation unit. Acknowledging a sense of inter-American comradeship, Colonel Moses observed that the close US-Colombian partnership “was not fictitious” and grew from “a feeling” that the two countries were “closely related.”<sup>13</sup> Another US officer remembered that the Colombians “just fit in really well” with American soldiers.<sup>14</sup> Colombian servicemen reinforced that observation. Captain Valencia Tovar, for example, found that the two armies “functioned in a very harmonious way.”<sup>15</sup> In Washington, the US Assistant Secretary of State noted that Bogotá’s Korean War contribution “had gained for Colombia great kudos” in Washington, making US officials more inclined to assist the republic.<sup>16</sup>

While Colombia contributed to the UN effort to preserve South Korea, the country’s domestic condition further deteriorated as *la Violencia* spread. This “disturbing” situation, a *New York Times* editor lamented, stood in stark contrast to the “bright heroism of the Colombian troops in Korea.”<sup>17</sup> Between 1951 and 1952 approximately 23,600 Colombians died as a result of the internal conflict.<sup>18</sup> President Gómez launched a variety of efforts, many heavy-handed, to control the fighting. His partisan and religious maneuvering only exacerbated the conflict. In early 1953, Colombian military officers led by General Rojas Pinilla, together with Conservative officials, began contemplating ways to end the Gómez government, which by most accounts (foreign and domestic) had been disastrous for Colombia. The plan had not matured when Gómez triggered a series of events that suddenly ended his administration. In a meeting at the Presidential Palace just hours after Gómez fled Colombia, General Rojas insisted that a civilian administer serve as president of the republic. When the civilian politicians refused, the general found himself holding the nation’s highest office.

The Colombian military ruled the country only twice before 1953, and never for more than one year. Colombian officers had been fiercely dedicated to civilian and constitutional authority since independence. Yet of all the institutions capable of ruling the country, only the armed forces were not discredited by *la Violencia*

and a decade of heated partisan combat. The Colombian Army and Navy's participation in the Korean War only enhanced the military domestic prestige. Philosophically, the Rojas government embraced "holy and patriotic concepts" that promised to help Colombians realize their "greatness."<sup>19</sup> General Rojas held strong religious convictions and believed that Colombia's quandary was in part a moral predicament. Convinced that Colombian identity lay in its Catholic tradition, the general therefore invoked Catholic religious and social doctrine to inspire unity. Honoring the legacy of the Simon Bolívar, the military government also extolled the ideas of "loyalty, honesty, modesty, strength, and moderation," which together might allow Colombia to move beyond *la Violencia* in the direction of some higher, albeit poorly articulated, purpose.<sup>20</sup> Practically, Rojas believed that Colombia's political and economic elite had placed personal gain above the interest of the country. The 1953 to 1957 program of military populism, "the era of the common man," therefore aimed to link the interests of the Colombian under class and military, allowing for new economic, social, political, and educational opportunities for the country's underprivileged majority. Since traditional political forces proved incapable of governing Colombia, Rojas and his colleagues promised to remake Colombia.<sup>21</sup>

These organizing themes of military governance took some time to evolve, and never exactly translated into a coherent program of government action. In fact, the circumstance that propelled General Rojas to power left the armed forces unprepared to govern Colombia and rudderless behavior too often characterized government action between 1953 and 1957. Still, the armed forces enjoyed considerable success during its first two years in power. Colombian servicemen promised to treat both Liberals and Conservatives with dignity and respect; citizens of both parties welcomed the military government. General Rojas repudiated media censorship and invited political exiles to return to Colombia. The general then developed an amnesty program to end domestic fighting. Approximately 16,000 guerrilla fighters rejoined mainstream society by the end of 1953 and in 1954 *la Violencia* claimed just 900 Colombian lives, compared to 13,250 in 1952.<sup>22</sup>

The military government simultaneously launched domestic programs designed to rebuild and uplift the republic. The Office for Aid and Rehabilitation assisted families affected by internal fighting and opened new economic opportunities for irregular combatants returning to peaceful enterprises. In 1954 Rojas Pinilla formed the *Secretariado Nacional de Asistencia Social* to help disadvantaged Colombians. The Ministry of Public Works, Institute of Industrial Development, Institute for Water and Electric Power Development, Institute for Colonization and Immigration, and regional development corporations undertook hundred of projects designed to accelerate Colombian modernization. At the same time, the military government distributed low-cost farm machinery, built a new inter-

national airport, inaugurated the country's first steel plant, reformed the tax codes, sponsored a new labor federation, launched two political parties, unveiled a social security program, and opened dozens of new educational facilities. In late 1953 the Eisenhower administration found the Rojas government to be "one of the most popular regimes Colombia had known," adding that Rojas had "brought about a healthy improvement" to the country.<sup>23</sup> The *New York Times*, a strong critic of Latin American dictators, found "overwhelming reasons to welcome and encourage the Rojas regime" for bringing peace to Colombia.<sup>24</sup> The Colombian armed forces had officially entered the state-building business with what appeared, at first, to be good results.<sup>25</sup>

General Rojas and his colleagues, however, were incapable of escaping the limitations of Colombia's deeply rooted bipolar political tradition. The general's failed political experiments, which one US embassy officer described as "reminiscent of Hitler, Mussolini and Perón," alienated Liberals and Conservatives.<sup>26</sup> Liberals, moreover, were disappointed that Rojas refused to return Colombia to civilian rule. They became further disenchanted with the general's inability to discern liberalism from communism. Over time, conservatives, industrialists, and clergy also abandoned the general for a variety of political, economic, and social reasons. Rojas Pinilla's growing unpopularity allowed for the gradual coming together of Colombia's two traditional parties, albeit in ways detrimental to the military government. The general responded to rising domestic opposition with an authoritarian campaign of harassment and oppression. Although he relaxed media censorship after the coup, he soon imposed new restrictions on the press. To secure his political power, Rojas engineered his own election, seated a puppet legislature, and remodeled the Supreme Court. He also abolished department and municipal assemblies, creating in their place military-appointed administrative councils. Throughout, the general refused to lift the state of siege (in place since the late 1940s), imposed strict regulations on labor and political meetings, mishandled student protests, and allowed government-sponsored pro-Rojas rallies to turn violent. The general became increasingly dislocated from the realities of national life by his most-trusted counselors, a group led by right-wing radical Lucio Pabón Núñez. By 1957 the military itself opposed General Rojas, especially young professional officers who valued the tradition of military subordination to constitutional rule.<sup>27</sup>

To compound the military's problems, the Rojas team, inexperienced in the area of public policy, formed initiatives in haphazard ways, constantly charted and re-charted initiatives, inspiring little confidence along the way. Importantly, Rojas's overall management of the economy brought hardship to Colombia. As the government alienated its constituents, knowledgeable civilian administrators turned their back on the military government. Without this pool of civilian talent,

the Colombian military simply lacked the knowledge and experience necessary to run a complex national economy. The gravest problems concerned government spending. The military's public works and social welfare projects cost millions of pesos each year. The general simultaneously lavished the armed forces with new facilities and "prestige" equipment. During the first eighteen months in power, Rojas covered these expenses with high returns on Colombian coffee. Crop failures in Brazil kept the price of coffee on the international market near \$1.00 per pound. But in February 1955 the coffee market collapsed and by 1957 the military accumulated a commercial debt exceeding \$450 million.<sup>28</sup> To add insult to injury, heavy rains, floods, and a major earthquake plagued the country from 1954 and 1956, erasing several high profile development projects and creating exorbitant disaster relief bills. Allegations of corruption and misconduct further diminished public support for the general, as did the reemergence of domestic fighting.

The growth of *la Violencia*, which began in 1946, was the final defining characteristic of the Rojas years. Despite the military's early success controlling the violence, the Rojas government failed to end the violence. When Rojas extended amnesty to guerrillas in 1954, some hardened fighters remained at large, either for ideological or personal reasons, while others who returned to peaceful enterprises kept their rifles close at hand, thus assuring the possibility for future disorder.<sup>29</sup> As opposition to the military government grew, so too did the *la Violencia*. In 1956 the conflict consumed 11,136 Colombians, an 80 percent increase over 1954 levels.<sup>30</sup> General Rojas, a passionate anticommunist, blamed the fighting on international communist agents. The government's occasional discovery of Soviet or Chinese arms and literature only confirmed Rojas's convictions. A US evaluation of the situation in April 1956 found that although the guerrillas had "no overall centralized direction" certain communists had "extended their influence in the guerrilla movement."<sup>31</sup> But the US embassy in Bogotá found "no overall proof" of widespread communist infiltration in Colombia, and the US Air Force attaché in Colombia recorded that "the mass of the guerrillas" wanted "nothing to do with the communists."<sup>32</sup> These and other assessments of *la Violencia* seemed to confirm a 1949 US embassy report that General Rojas could not "tell a communist from a Liberal" and tended to see "Red hiding behind every coffee bush."<sup>33</sup>

The festering violence involved the Colombian military in new ways. Whereas former-presidents Ospina and Gómez used the National Police and Conservative militias to control the violence, Rojas pressed the armed forces into domestic security duties. As such, the Korean War and Colombia's pre-existing security alliance with the United States influenced the course and direction of *la Violencia*. Wartime lessons in communication, sanitation, logistics, fortification, and combat were valuable and applicable in domestic operations. Moreover, soldiers "who had

Korean War experience in night patrolling and attacks,” concluded one Colombian officer, “were extremely effective against the guerrillas.<sup>34</sup> Yet the Colombian Army’s commitment to conventional tactics in the face of an unconventional conflict produced mixed results. In the years before 1950, the Colombian Army had developed a military outpost system. The Korean campaign reinforced the utility of such a network, and by late 1954 the army maintained hundreds of outposts, including forty-two separate fortified stations in Ibaque alone. From these positions, Colombian infantrymen patrolled the countryside. Soldiers frequently tangled with irregular forces that descended upon the government formations. When attacked, the Colombian Army fought decisive battles, often with mixed results. In April 1955, after bandits ambushed a Colombian Army unit in Tolima, Rojas declared a section of that department a Zone of Military Operations. The army then isolated the area, encircled what it believed to be 3,000 communist guerrillas and launched a full-scale military assault. That operation employed thousands of Colombian servicemen and killed many antigovernment fighters. But the Villarrice campaign also inflicted heavy casualties on innocent *campesinos*.<sup>35</sup>

Through its affiliation with the United States, the Colombian armed forces had trained for a conventional war, not counterinsurgency or police missions. Uniformed servicemen therefore grew frustrated with the guerrilla-style combat. Many claimed to be “reluctant” to operate against guerrilla force for fear of killing innocent civilians.<sup>36</sup> In some circumstance these conditions resulted in misconduct. When guerrillas ambushed and killed six Colombian soldiers near Chaparral in late April 1956, Colonel Rafael Villate responded by rounding up and killing approximately eighty persons that had provided “aid and comfort to guerrillas.”<sup>37</sup> Similar incidents, although not common, occurred elsewhere. Remarkably, as the fighting expanded, the Rojas government proved unreceptive to peaceful solutions, such as when Pabón Núñez terminated a bipartisan peace effort in Tolima for fear that members of the two traditional parties might grow too friendly and threaten the regime.<sup>38</sup> Rojas responded to the violence by enlarging the military and its campaign against the guerrillas. By 1957 the Colombian Army enlisted over 47,000 troops (compared to 22,000 in 1950); the armed forces were still too small to cover the large and geographically rugged country.<sup>39</sup> And more than one US military observer became convinced that Rojas Pinilla was not doing all he could to control *la Violencia*, some even suggesting that the general was “allowing the fighting to continue in order to justify” his continuation in power.<sup>40</sup> In any case, beginning in 1953, Colombian officials realized that they needed to remodel the military establishment to cope with its new domestic security and state-building missions. Colombian officers turned to the United States for assistance.

In its military relations with Latin America, the Eisenhower administration (1953-1961) pursued many traditional US objectives, goals first outlined during the Roosevelt and Harry S. Truman administrations. The Eisenhower team wanted to build Latin American military forces capable of participating in hemispheric defense operations. Such units would help protect commercial routes and raw material deposits. During World War II, Washington assigned approximately 400,000 US servicemen to defend the Western Hemisphere. If the United States could improve Latin American military proficiency, those US units might be assigned to the fighting front. The Pentagon also continued to press for the standardization of inter-American military organization, doctrine, and equipment, so as to make future wartime collaboration effective and efficient. In the event of World War III, the United States could supply and maintain Latin American units that employed US equipment; standard equipment also maximized the expertise of US military advisers and the practical value of Latin American training at US service schools. At the same time, organizational and operational compatibility increased the likelihood of successful joint operations. Finally, US planners encouraged the development of Latin American military units capable of participating in collective security operations in distant theaters. Latin America's general unwillingness to fight in Korea, however, dampened the Eisenhower administration's enthusiasm for this pre-existing US objective. In its place, the Eisenhower administration, mindful that communist insurgencies threatened hemispheric stability, gradually began emphasizing internal security issues.

Upon taking office, the Eisenhower administration launched a vigorous reappraisal of US national security policy. National Security Council (NSC) Report 153/1, approved by the president on 10 June 1953, acknowledged the need "to strengthen the will and ability of other nations of the free world, individually and collectively, to deter or oppose communist aggression and achieve internal security."<sup>41</sup> To accomplish this objective, the United States should "encourage and assist the development of indigenous free world armed forces, and regional and collective security arrangements of the free world, capable of an increased share of responsibility in resisting local communist aggression."<sup>42</sup> Yet seeking a sustainable, long-term strategy for waging the Cold War against international communism, the Eisenhower team, keen on limited foreign assistance spending, did not contemplate large assistance programs for Latin America. Washington decided, instead, to devote more attention, not money, to its southern neighbors. An October 1953 NSC paper concluded that the United States should only provide allies with "limited military aid, and limited technical and economic assistance" consistent with "the calculated advantage of such aid to the US world position."<sup>43</sup>



The American position began to change in 1954. Soviet-American atomic parity and the death of Soviet Premier Josef Stalin, US policymakers concluded, made total war less likely. Americans grew increasingly concerned that communist insurgencies, rather than a conventional showdown, would tip balance in favor of Soviet Union and Communist China. "The USSR has greatly modified its tactics and techniques for achieving its objectives in the political, psychological and economic fields," a key 1954 NSC paper argued.<sup>44</sup> The United States needed to adapt to these new security challenges. At the highest levels, Colombia rarely figured into US calculation: it was a reliable ally in the hands of a friendly, noncommunist general. The NSC nonetheless believed that communists in Colombia, although "small in actual number," would "take advantage" of instabilities to advance their cause.<sup>45</sup> The United States therefore responded favorably to Colombian overtures for internal security assistance. The Eisenhower administration did not discard traditional hemispheric defense goals. It did affect a gradual shift in the tone and emphasis of US military assistance that supported the Colombian military's state-building effort and foreshadowed the wholesale readjustment of bilateral military relations after 1959.

The rise of the military government in Colombia delivered an exceptional opportunity for closer bilateral military relations. Without civilian oversight, the Colombian armed forces controlled their own development. US military officials had more contact (and influence over) high-ranking government officials than at any time since the republics came together in 1939. In 1951 a US military adviser in Colombia had praised General Rojas as both "a very able officer" and a man "keen" on American "ways and ideas."<sup>46</sup> In fact, as a young man, the general had studied in the United States and worked in both New York and Detroit before returning to Colombia to begin his military career. As president, the general showed an unmovable commitment to anticommunism and inter-American unity. The general's passionate anticommunism grew, in part, from his religious convictions. Rojas believed that atheistic communists sought to destroy the "treasures" bestowed on Colombia by "the hand of Christ."<sup>47</sup> Rojas personally cultivated and expanded Colombian-American military, diplomatic, and economic collaboration. The general aligned Colombia with the world's democracies even as his domestic résumé raised troubling questions. He also believed that because Colombia had fought in Korea it was uniquely positioned to help transform the Americas into an "impregnable bastion of liberty."<sup>48</sup>

The Eisenhower administration drew confidence from the military government's commitment to anticommunism, if not the hibernation of Colombia's democratic tradition, and harbored no doubt that Bogotá would work with the United States in future security operations. Indeed, US naval mission chief Captain Jay V.

Chase observed that Colombia's Korean War contribution alone was "adequate evidence of mutual cooperation" to justify Washington's investment in Colombia.<sup>49</sup> The Colombian Army's work with the United Nations Emergency Force after the 1956 Suez Crisis only added to Colombia's position as a proven leader in collective security operations. Therefore, between 1953 and 1957, to help the Colombian military government, the United States' relaxed oversight of military aid, provided arms, engineering equipment, and other materiel to the Colombian military; helped train specialized Colombian counterinsurgency units; participated in revising the Colombian recruit training program; and contributed technical and materiel assistance to assorted Colombian military state-building projects.

One of the major US goals in Latin America during the 1950s remained developing Latin American military units capable of participating in hemispheric defense operations. At the 1951 Foreign Minister's Conference in Washington, inter-American officials recommended that the Latin American republics form special military units, supported by US grants, for the purpose of hemispheric defense. The US Congress quickly passed Military Assistance Program (MAP) legislation to support such forces, and Colombia and the United States signed a bilateral MAP agreement in 1952. For the purpose of defending the Americas, Truman administration agreed to provide US grant aid for a Colombian anti-aircraft battalion, two air squadrons, and two warships. In 1954, as the Colombia Infantry Battalion prepared to leave Korea, the Pentagon extended some support to that unit as well.<sup>50</sup> President Gómez established Colombia's anti-aircraft battalion in January 1953, and by July the Pentagon had delivered approximately 75 percent of the battalion's equipment. Washington immediately provided for the training of 500 soldiers to man the 40-mm guns.<sup>51</sup> Between 1954 and 1955 the United States also shipped arms and equipment for the Colombia Infantry Battalion to Bogotá. US advisers began flight training for Colombian airmen assigned to the two MAP air squadrons in August 1953. That same year eleven F-47s arrived in Colombia, and the fighter squadron was operational by 1954. Due to supply problems, Washington shipped the B-26 bombers to Colombia only in March 1956.<sup>52</sup> The inter-American defense program also provided for the improvement of Colombia's two destroyers. In 1953 and 1954 the US Navy refitted the ARC *Antioquia* and ARC *Caldas* in Mobile, Alabama. The Colombian vessels, in turn, participated in several joint training exercises with the US Navy. But by 1950s standards, the Colombian destroyers were still obsolete, and Colombian naval officials asked Washington to loan Colombia two modern warships. US planners agreed, but were not able to provide the ships, formerly the USS *Stanley* and USS *Hale*, until 1960.<sup>53</sup>

Colombia's US-supported MAP units were, by US law and Colombian-American treaty, strictly limited to inter-American defense activities. Colombian officers

could not use the units or their equipment for internal security operations. The Truman administration strictly monitored the units, and even delayed the delivery of some materiel, fearing President Gómez would use US arms for domestic security purposes.<sup>54</sup> The Eisenhower administration, viewing internal security in new ways, relaxed US oversight. During the 1955 campaign in Tolima, Bogotá (without US permission) deployed some MAP air assets against guerrillas, resulting in the destruction of one US-furnished aircraft and the consumption of a good quantity of small and heavy arms ammunition. During that same operation, the Colombian Army rushed two MAP anti-aircraft guns to the fighting front for use against ground targets. US diplomats were understandably concerned when they discovered how Rojas had used the equipment. Department of State officials, mindful of legal restrictions governing use of MAP assets, started drafting a formal protest. But the Pentagon and NSC intervened, informally advising the US State Department to drop the issue. Internal security, the administration concluded, was a fundamental aspect of Colombia's hemispheric defense mission.<sup>55</sup> Around the same time, the Colombian and American officials, notably the ambassador in Bogotá, began contemplating ways to realign US MAP assistance to better support the Colombian military's state-building work. Both sides began talking about replacing the US-supported anti-aircraft battalion with an engineering unit that might contribute to Colombian economic development, thereby addressing some of the root problems of *la Violencia*. The plan yielded results only after the Rojas government collapsed, but reflected broader thinking about MAP activities. By 1965 the United States supported twenty-six MAP units in Colombia, including six engineering battalions and assorted counterinsurgency units, all cleared by the US Congress to undertake domestic security and state-building activities.

In addition to MAP grant aid, Colombia purchased a vast quantity of US military equipment (lethal and non-lethal) from the United States. Between 1953 and 1954 the Rojas government lobbied the United States, unsuccessfully, for a larger share of MAP assistance. In doing so, the military government used its Korean War service to leverage US officials. Indeed, in July 1955 Deputy Undersecretary of State Robert Murphy observed that Bogotá based a "very large part" of its case for more MAP aid on the notion that its part in the Korean campaign had afforded Colombia "a legitimate and preferential claim" to US military assistance.<sup>56</sup> But in an era of limited US foreign assistance, Latin America received only a small share of US foreign military aid. In 1954, for example, Pacific and Asian countries received \$583 million in US military grants, while the United States dispatched just \$13 million to Latin America.<sup>57</sup> The Rojas government, already the leading Latin American recipient of MAP assistance, nonetheless pushed the United States to enlarge its role in hemispheric defense, and thus its share of US military aid. General Rojas proposed that the Latin American countries form a standing inter-

American army, one in which Colombia, by way of its Korean War experience, would presumably play a leading role. Colombians later asked the United States to support a Colombian MAP infantry division; the request for assistance totaled nearly \$150 million, more US military aid than Washington had slated for the entire Western Hemisphere.<sup>58</sup> In both cases, the United States rebuffed Bogotá's overtures for more grant support. American officials did agree to sell arms and equipment to the Colombian government.<sup>59</sup>

The 1954 Mutual Security Act liberalized the conditions of US arms sales, allowing foreign governments to purchase weapons at a "fair value"—not actual cost—and to finance those purchases over a three year period.<sup>60</sup> Many foreign governments, however, found direct US arms sales unattractive. American equipment remained expensive and the Pentagon was often slow in delivering materiel. In an inter-American context, the Korean War diminished some of these problems for Colombian purchasers. In 1955 one Pentagon official admitted that "all US military officers were very conscious" of Colombia's "comradeship in the Korean Conflict," and considered Bogotá arms requests accordingly.<sup>61</sup> Also, Colombian military attachés in Washington, such as former Colombia Battalion commander Jaime Polanía, were often Korean War veterans that could call upon their US comrades to expedite sales. Between 1953 and 1957 Bogotá therefore purchased a large quantity of US heavy weapons, rifles, ammunition, land mines, and grenades. Bogotá also outfitted its new Marine Corps section with US arms through direct purchases from the Pentagon. The Colombian Air Force and Navy acquired spare parts, munitions, and maintenance equipment. Unlike MAP assistance, the US Congress placed no restrictions on the use of these lethal items. The military government therefore used the materiel to prepare for hemispheric defense and maintain internal security. Also, the Pentagon sold to Colombia a significant amount of equipment to support internal development projects related to the Colombian military new role as a state-building instrument. During the mid-1950s, the Colombian armed forces purchased a substantial amount of construction equipment such as tractors, dump-trucks, bull dozers, backhoes, earth-moving explosives, communications gear, and bridges-making tools. Overall, through the provision of the 1954 Mutual Security Act, Colombians purchased roughly \$500,000 of US equipment each year; in 1956, Colombia bought over \$1.1 million in US military supplies.<sup>62</sup> Combined with MAP grant aid, it was the greatest infusion of US arms into Colombia to that point in history. Indeed, Colombia, a second tier recipient of US military aid before Korea, received more American assistance during the 1950s than any other Latin American country.

Although generous, Washington imposed some limits on sales. In 1955 Colombian diplomats tried to purchase napalm bombs from the United States. Assis-

tant Secretary of State Henry F. Holland urged the Colombian ambassador to consider the “intense emotional opposition” that would develop in the United States as a result of the sale of napalm to Colombia.<sup>63</sup> After several meetings with the Colombian ambassador, US officials persuaded Colombia to drop the order; Rojas instead purchased bomb-making equipment on the open market and manufactured the napalm in Colombia, illustrating the fact that a foreign government with money and determination would acquire arms with or without a US approval. In fact, when Bogotá proved incapable of fulfilling its material needs through the Pentagon, the military government, like its Latin American counterparts, turned to suppliers in Belgium, Sweden, France, and the Dominican Republic. These purchases undercut Washington’s objective of hemispheric arms standardization and created supply problems for Colombian forces. They also saddled the Rojas regime with debt, leading one US military adviser in Colombia to conclude that Bogotá “could pay off” Colombia’s “commercial indebtedness in double-quick time” if General Rojas just stopped buying foreign arms.<sup>64</sup> Even so, the US government armed and equipped the Colombian military during the 1950s with conventional war-making materiel and construction equipment that supported (directly or indirectly) the Colombian military’s state-building effort.

The United States also contributed to the Colombian military’s new domestic mission by helping Colombian officers remodel their recruit training system. The US military participated in the training of Colombian officers during World War II. In January 1956, after nearly fifteen years of cooperation in the area of military education, the Eisenhower administration observed that “most key officers” in the Colombian armed forces had studied at US service schools. US advisers also helped prepare Colombian infantrymen before they entered combat in Korea.<sup>65</sup> Yet between 1953 and 1957 Colombian officers first involved US officials in the training of Colombian military recruits, young men just entered into military service. In January 1954 Bogotá sent US Army mission chief Colonel Robert Turner on a tour of Colombian military facilities on the eastern plains, one of the areas hardest hit by *la Violencia*, to review Colombian military organization, especially the outpost system and training practices. Turner’s report, submitted to the Rojas government in March 1954, criticized the fact that the Colombian Army did not operate a central training facility. Instead, outpost commanders received raw recruits, most often pulled from surrounding towns and villages. Bogotá charged the local commands with the basic training of these soldiers. The rapid expansion of the Colombian Army under Rojas exposed problems in Colombia’s preparation of servicemen, dilemmas compounded by the fact that 50 percent of new recruits were illiterate. Colonel Turner found that this system placed an undue burden on field units and accounted for an overall lack of standardized training for Colombian soldiers.<sup>66</sup> Therefore, after studying Turner’s report, Colombian officers asked the United

States for assistance in creating a Recruit Training Center that would provide for the continuous preparation of new soldiers.

The training center became Rojas's special project and the general himself made most of the major decisions affecting the center. The Pentagon arranged for ten Colombian officers to spend several months at the US basic training facility at Fort Jackson, South Carolina, to observe US practices and procedures. Washington also dispatched three officers to help Colombian officials develop Recruit Training Center courses, literature, and schedules. A fourth adviser, US Army Corps of Engineers Colonel John C. Lowry, oversaw the physical construction of the center. Colombian and US officers disagree on aspects of the project. The Americans disliked the location in Meglar. They believed that area, although large enough to train several thousand recruits a year, was too small to conduct major field exercises. Colonel Turner eventually conceded the point, recognizing that Melgar's appeal, a short distance from Rojas's own country estate, was too much for the general to resist. Also, since General Rojas spared no expense on the facility, US officers in Colombia believed that the Recruit Training Center was too opulent and expensive. Again, the general's interests prevailed.<sup>67</sup>

Opened in January 1957, the Recruit Training Center offered new soldiers a diverse educational experience. Courses included instruction in reading and writing, personal hygiene, citizenship, Colombian history, and military science. Instructors taught students the fundamentals of military service, including self-discipline, rifle and small arms training, and small unit tactics. For many recruits, most of whom would not pursue military careers, the Colombian Army Recruit Training was the only formal education they received in their lifetime. The program did more than train enlisted personnel for military service; it endeavored to prepare young Colombian men to be good citizens.

Colonel Turner's 1954 report also proposed that the Colombian Army form special Ranger units for internal counterinsurgency operations. That same year, Colombian authorities, embracing Turner's suggestion, petitioned the United States for help in establishing the *Escuela de Lanceros*, or Ranger school, at Melgar. The Eisenhower administration threw its support behind the plan in mid-1954. Both governments believed that special warfare training for Colombian soldiers would help Colombia address the country's persistent guerrilla activity and promote Colombia's internal security. Captain Ralph Puckett, Jr., a US Ranger and Korean War veteran, joined Colombian officers to establish curricula and training schedules, as well as the center's physical layout. When the *Escuela de Lanceros* opened in late 1955, Captain Puckett served as a special Ranger adviser to the school commandant Major Hernando Bernal Duran. Four Colombian lieutenants

traveled to Fort. Benning to study at the US Ranger School; upon their return, these men formed the corps of the *lancero* training cadre.

The grueling eleven-week training program pressed students to their physical and mental limits. The initial phase focused on physical conditioning, small arms training, survival techniques, and map reading. Instructors, many of whom were specially trained in the United States, or themselves *lancero* graduates, pushed students twelve hours a day. The second phase involved field exercises under simulated combat circumstances. To encourage self-criticism and peer-review, students constantly graded themselves and their fellow students. The final exercise involved a series of long-range patrols, each lasting three or more days. These actions involved tough geographic obstacles (mountains, rivers, and jungles) and numerically superior “enemy” forces. Colombia’s Korean War veterans often worked at the school as mock opponents for the *lancero* students. In 1959 the Colombian Army made the *Escuela de Lanceros* a requirement for all second lieutenants, and by 1960 the special warfare school produced approximately 200 graduates each year. Lieutenant John R. Galvin, who replaced Puckett in April 1957, happily reported that the efficiency of *Escuela de Lanceros* neared that of its US counterpart.<sup>68</sup> The Ranger school was the first attempt to create Colombian military units designed specifically to tackle Colombian internal security operations. Colombian Rangers played an important part in fighting domestic insurgents after 1958.

In addition to these ventures, the United States supported the Colombian military state-building work through various other activities that merged US civilian and military expertise. The Rojas government made a large investment in developing a modern military hospital in Bogotá. Planning for the facility actually began in 1949 and workmen started construction in late 1951, but the medical center was far from finished when General Rojas came to power. During the mid-1950s the United States furnished equipment and technical assistance for the 750-bed facility. Colombian medical personnel trained in the United States; the center opened in 1955 under the direction of Columbia University graduate Dr. Alfonso Ramirez.<sup>69</sup> US advisers also worked with the Colombian Navy on ways to effectively control the country’s river systems in support of army internal security operations. The US Air Force mission, under command of Colonel Algene E. Key, helped Colombians establish a new airfield and aircraft maintenance center at Cali.<sup>70</sup> In 1955, anticipating Colombia’s purchase of modern jet airplanes, Colombia and the United States launched a jet pilot training program, valuable to military and civilian sectors.<sup>71</sup> Around the same time, the two governments also reinvigorated the US civil aviation mission, including a new team of US engineers that worked with the Colombian military to build Colombia’s *El Dorado* international airport. American civilians, through Point IV technical agreement, worked with the Colombian armed

forces on housing and modernization projects. Tennessee Valley Authority administrators and engineers helped Colombian military authorities implement regional development plans. American loans supported highway and railroad construction projects and the United States invested \$45 million in a Colombian hydroelectric plant. The two countries also launched a Cooperative Meteorological Observation Project with both military and civilian applications.<sup>72</sup> Finally, Americans worked with Colombian military police and clandestine services to improve domestic law enforcement capabilities.

There were, however, limits to US assistance. In 1957 the military government, in a desperate financial situation, asked Washington for an economic aid package to stabilize the country. The Eisenhower administration purposefully balked until a series of nation-wide strikes toppled the general in May 1957. The following year, a Colombian military junta returned the country a bipartisan civilian coalition known as the National Front. An extension of the Liberal-Conservative political partnership that toppled General Rojas, the National Front provided for a sixteen-year bipartisan government, splitting elected and appointed posts evenly between the two parties and alternating the four-year presidency between Liberal and Conservative politicians. The new government ended *la Violencia* as a political dispute, but staggering social, economic, religious, and security problems remained unsolved. Wanting to encourage the resurgence of Colombian democracy, the Eisenhower administration responded to Colombia's urgent need for assistance with generous economic aid. In doing so, Washington considered two other inter-American events—Vice President Richard Nixon's disastrous South American tour (1958) and the Cuban Revolution (1959). In combination, the anti-American occurrences convinced US authority that they needed to do more for Latin America. A devoted Cold War ally and promising democracy, Colombia therefore received an impressive \$500 million in US economic assistance between 1958 and 1960.

At the same time, US and Colombian officials completed the remodeling of the bilateral security alliance. In 1959 the first National Front president, Alberto Lleras Camargo, proposed that the United States furnish Colombia with MAP grant aid to transform the Colombian military into an effective internal security tool. President Lleras believed that the ongoing disorder threatened the fragile National Front coalition, inflicted hardship and suffering on Colombian citizens, slowed modernization, and made the country vulnerable to communist subversion. Lleras, in short, wanted to transform the Colombian military into an institution capable of solving the country's security dilemma. In 1959, he directly challenged the Colombian Army to "keep abreast" of changing trends in warfare, and implement reforms for the purpose of developing counterinsurgency techniques.<sup>73</sup>



With these objectives in mind, President Lleras called the US military advisers to the Presidential Palace on 8 June 1959. During that conference, the president explained Colombia's need for counterinsurgency capabilities. Lleras himself drew upon the Cuban situation to illustrate the danger that faced Colombia. President Lleras then outlined his plan to build a special military unit consisting of 1,500 Ranger troops, mobilized aboard US-supplied helicopters, and armed with the latest US arms. Because Colombia's economic situation prohibited the outright purchase of the equipment, Lleras asked that the battle group receive MAP support.<sup>74</sup> While recognizing that MAP legislation still prohibited the use of US grant aid for internal security purposes, despite the relaxation of oversight during the Rojas period, the US officers forward the Colombian request to Washington. Intrigued by the proposal, the Eisenhower administration dispatched a joint Department of Defense/Central Intelligence Agency team to South America to survey Colombia's internal security situation. The survey group findings, Washington's new appreciation for Latin American insecurity, and Colombian President Alberto Lleras's personal approach to President Eisenhower during an April 1960 visit to Washington converted the US-Colombian security partnership into an alliance focused on Colombian internal security. At the end of his presidency, Eisenhower, invoking a provision of the 1958 Mutual Security Act, signed a MAP waiver that allowed Colombians to use grant aid in domestic security operations. In mid-1961, a few months after John F. Kennedy moved into the White House, the Colombian Army received a "special" delivery from the United States: the first three helicopters for President Lleras's counterinsurgency force.<sup>75</sup> It marked the beginning of a new era of Colombian-American security cooperation.

The US response to the Colombian President Alberto Lleras's 1959 overture reoriented the US-Colombian security relationship. Yet this essay finds that bilateral relations between 1953 and 1957 prepared both countries for the shift in direction. Also, this paper shows that Colombian-American security relations mimicked changes in the domestic state-building responsibilities of the Colombian armed forces. Although the Rojas regime failed to achieve its stated objectives, it turned the Colombian military into a state-building instrument, with important long-term consequences. After 1957 the Colombian armed forces divested themselves of many traditionally civilian chores, but still played an important role in ending *la Violencia*; they remain today a widely respected state-building institution. Additionally, this study concludes that Colombians were key agents of change. During the era of Colombian military rule, Bogotá worked to channel and direct US military assistance in ways that supported the armed forces in their new state-building duties. Adjusting the bilateral alliance, Colombians relied on their Korean War service, strategic location, and shared Colombian-American experiences and values. Throughout, Colombians packaged their security interest to connect with prevailing

US security concerns. Also, analytically, this essay finds that Colombian government successfully used US support and assistance to overcome domestic difficulties. American aid did not end *la Violencia*. The ultimate resolution of the conflict depended on Colombian internal developments beyond US control. Nevertheless, Colombian-American security relations during the 1950s reveal that US foreign assistance, properly utilized, can support internal processes that produce order, stability, and democracy. Finally, this paper posits that Colombian-American security relations should be incorporated into the broader history of the Cold War. During the 1950s the Eisenhower administration feared that a shift in communist tactics, conventional to unconventional, might tip the great power competition in favor of the Soviet Union and Communist China. Evolving US security concerns explain, in part, the favorable US response to Colombian overtures during the 1950s. Other Cold War aspects, including Colombia's involvement in Korea, also influenced US-Colombian relations. Building armies in places such as Colombia, the United States sought to create friendly, secure nations, allies in the Cold War against communism. More than the beginning of the modern Colombian-American security alliance, the transformation of the US-Colombian relationship shows that the Cold War was a truly international event with global consequences.

## Endnotes

1 This paper is based on Bradley Coleman's book-in-progress, *Colombia and the United States: The Making of an Inter-American Alliance, 1939-1960* (Kent, Ohio: Kent State University Press, forthcoming, September 2007). The views expressed here are the author's own and do not necessarily represent those of the Department of State, his current employer.

2 Bradley Lynn Coleman, "The Colombian Army in Korea, 1950-1954," *Journal of Military History* 69 (October 2005): 1137-78; Mark H. Danley, "Colombian Navy in the Korean War, 1950-1953," *American Neptune: A Quarterly Journal of Maritime History and Arts* 58 (Spring 1998): 243-61; and Russell W. Ramsey, "The Colombia Battalion in Korea and Suez," *Journal of Inter-American Studies* 9 (October 1967): 541-60.

3 Dennis Rempe, "An American Trojan Horse?: Eisenhower, Latin America, and the Development of US Internal Security Policy, 1954-1960," *Small Wars and Insurgencies* 10 (Spring 1999): 34-65; "Guerillas, Bandits, and Independent Republics: US Counterinsurgency Efforts in Colombia, 1959-1965," *Small Wars and Insurgencies* 6 (Winter 1995): 304-27; "The Origins of Internal Security in Colombia: Part I – A CIA Special Team Surveys *la Violencia*, 1959-1960," *Small Wars and Insurgencies* 10 (Winter 1999): 24-61; *The Past as Prologue?: A History of US Counterinsurgency Policy in Colombia, 1958-1966* (Carlisle, Pennsylvania: Strategic Studies Monographs Series, 2002); and "Counterinsurgency in Colombia: A US National Security Perspective, 1958-1966" (Ph. D. Dissertation, University of Miami, 2001).

4 For coverage of the role of the military in Colombia society, see James O. Icehour, "The Military in Colombian Politics" (M.A. Thesis, George Washington University, 1976); Anthony Maingot, "Colombia: Civil-Military Relations in a Political Culture of Conflict" (Ph.D. Dissertation, University of Florida, 1967); Adolfo León Atehortúa and Humberto R. Vélez, *Estado y fuerzas armadas en Colombia: 1886-1953* (Cali, Colombia: Pontificia Universidad Javeriana, 1994); and Alain Rouquié, *The Military and the State in Latin America*, translated by Paul E. Sigmund (Berkeley, Los Angeles, London: University of California Press, 1989).

5 See Silvia Galvis and Alberto Donadio, *El Jefe Supremo: Rojas Pinilla en la Violencia y el poder* (Bogotá, Colombia: Planeta, 1988); María Eugenia Rojas, *Roja Pinilla, mi padre* (Bogotá, Colombia: Panamericana Formas e Impresos, S.A., 2000); Alvaro Valencia Tovar, *Historia de las fuerzas militares de Colombia* (Bogotá, Colombia: Planeta, 1993); and Valencia Tovar and Jairo Sandoval Franky, *Colombia en la Guerra de Corea: La historia secreta* (Bogotá, Colombia: Editorial Planeta Colombiana, 2001).

6 Wiley to Secretary of State, 22 August 1946, 820.00, Box 183, Department of State, Bogotá Embassy, General Records, 1946, Record Group (RG) 84, National Archives and Records Administration (NARA), College Park, MD.

7 See "Information Regarding Staff Conversations Between Military and Naval Representatives of the United States and Colombia," September 1945, Box 70, Department of State, Bogotá Embassy, Classified Records, 1944-1945, RG 84, NARA.

8 Zuleta Angel to Gómez, 21 August 1950, Folio 229, Box 87, Records of the Colombian Embassy in Washington, Archivo General de la Nación, Bogotá, Colombia.

9 Conferencia del ministro de relaciones exteriores, dictada desde la radiodifusora nacional el 20 de agosto de 1952 (Bogotá, Colombia: Imprenta Nacional, 1952), 7.

10 For more on the US effort to field an international coalition, and Colombia's decision to send troops to Korea, see Bradley Lynn Coleman, "The Colombian-American Alliance: Colombia's Contribution to US-Led Multilateral Military Efforts, 1938-1953" (Ph.D. Dissertation, University of Georgia, 2001), 138-54.

11 "United States Policy Toward Inter-American Military Cooperation," 1 November 1952, President's Secretary's Files, 1945-1953, "National Security Council," Box 195, Harry S. Truman Papers, Harry S. Truman Library, Independence, Missouri.

12 Moses Interview, 3 May 1971, in Daniel Davison, "The Colombian Army in Korea: A Study of the Integration of the Colombia Battalion into the 31st United States Infantry Regiment Based on the Experiences of Major General Lloyd R. Moses" (M.A. thesis, University of South Dakota, 1972), 107.

13 Author's Interview with T. C. Mataxis, 8 August 2002.

14 Valencia Tovar to Author, 14 January 2001.

15 Edward Miller to Harold Tittmann, 5 November 1951, *FRUS*, 1951, II: 1601.

16 *New York Times*, 24 November 1951.

17 James Henderson, *Modernization in Colombia: The Laureano Gómez Years, 1889-1965* (Gainesville, Florida: The University Press of Florida, 2001), 24.

18 *El Tiempo*, 8 March 1954.

19 *La Republica*, 7 August 1954.

20 *El Tiempo*, 13 June 1954; Bushnell, *The Making of Modern Colombia*, 215-22; and "President's Remarks on Publics Order and the Role of the Church," 16 July 1955, 370.00, Box 6, Department of State, Bogotá Embassy, Classified General Records, 1953-1955, RG 84, NARA.

21 Henderson, *Modernization in Colombia*, 422.

22 "Memorandum by Albert H. Gerberich of the Office of South American Affairs," 12 November 1953, *Foreign Relations of the United States (FRUS), 1952-1954*, IV: 805; and Serpa, *Rojas Pinilla*, 213-18.

23 *New York Times*, 4 September 1953.

24 Dirección de Información y Propaganda, *Seis meses de gobierno* (Bogotá, Colombia: Imprenta Nacional, 1953); "Annual Radio Report of Minister of Development," 10 June 1955, 361.2, Box 2, Department of State, Bogotá Embassy, General Records, 1953-1955, RG 84, NARA; *El Tiempo*, 6 June 1955; "Annual Report to the National by the Minister of Public Works," 11 July 1956, 821.261/7-1156, Box 4249; "Description of the Cauca Valley Project," 25 May 1955, 821.211/5-2555, Box 4247, Department of State, Decimal File, RG 59, NARA; Rojas, *Rojas Pinilla, mi padre*, 196-221; and Serpa, *Rojas Pinilla*, 237-38. "Monthly Political Summary," 1 July 1956, Box 5; Bosnal to Dulles, 14 June 1956, 350.00, Box 4; and "Summary and Assessment," 9 July 1957, 320.00, Box 2, Department of State, Bogotá Embassy, Classified General Records, 1956-1958, RG 84, NARA.

25 "Monthly Political Summary," 1 July 1956, Box 5, Department of State, Bogotá Embassy, Classified General Records, 1956-1958, RG 84, NARA.

26 Serpa, *Rojas Pinilla*, 246-249, 268-70; "Monthly Political Summary," 3 September 1957, 350.00; and US Embassy to Secretary of State, 29 April 1957, 350.00, Box 5,

Department of State, Bogotá Embassy, Classified General Records, 1956-1958, RG 84, NARA.

27 "Monthly Political Summary," 2 January 1957; and "Monthly Political Summary," 1 October 1957, Box 5, Department of State, Bogotá Embassy, Classified General Records, 1956-1958, RG 84, NARA.

28 "Violence in Colombia," 23 January 1958, 350.00, Box 4, Department of State, Bogotá Embassy, Classified General Records, 1956-1958, RG 84, NARA.

29 Henderson, *Modernization in Colombia*, 422.

30 "Communist Control of Guerrilla forces in NIE 88-56," 11 April 1956, 350.00, Box 4, Department of State, Bogotá Embassy, Classified General Records, 1956-1958, RG 84, NARA.

31 "Situation of Violence in Colombia: Survey and Assessment," 31 October 1955, 370.00, Box 6, Department of State, Bogotá Embassy, Classified General Records, 1953-1955, RG 84, NARA; and "Debriefing on Colombia by Lt. Col. Rex T. Barber, Air Attaché at Bogotá," 31 May 1956, 350.00, Box 4, Department of State, Bogotá Embassy, Classified General Records, 1956-1958, RG 84, NARA.

32 Mills to Gerberich, 17 November 1949, 821.00/11-1649, Department of State, Decimal Files, 1945-1949, Box 5243, RG 59, NARA.

33 Quoted in Charles Lowndes Steel IV, "Colombian Experiences in Korea and Perceived Impact on *La Violencia*, 1953-1965" (M.A. thesis, University of Florida, 1978), 45.

34 Henderson, *When Colombia Bled*, 181-252.

35 *New York Times*, 18 November 1956.

36 "Monthly Political Summary," 1 June 1956, 320.00, Box 5, Department of State, Bogotá Embassy, Classified General Records, 1956-1958, RG 84, NARA.

37 "Violence in Colombia," 16 May 1956, 350.00, Box 4, Department of State, Bogotá Embassy, Classified General Records, 1956-1958, RG 84, NARA.

38 "Monthly Political Summary," 1 March 1957, 350.00, Box 5, Department of State, Bogotá Embassy, Classified General Records, 1956-1958, RG 84, NARA.

39 General Louis V. Hightower to Lieutenant General Clyde D. Eddleman, 21 March 1956, Box 2, Records of the Deputy Chief of Staff for Military Operations, Classified General Correspondence, 1956, RG 319, NARA.

40 NSC 153/1, 10 June 1953, *FRUS*, 1952-1954, II: 381.

41 *Ibid.*, II: 384.

42 NSC 162/2, 30 October 1953, *FRUS*, 1952-1954, II: 593.

43 Paper Prepared by the Director of the Foreign Operations Administration, 9 November 1954, *FRUS*, 1952-1954, II: 770

44 "Outline Plan of Operations for Colombia," Operation Coordinating Board (OCB), 24 January 1956, White House Office Files, OCB Central Files, Box 28, Folder "Colombia," Dwight D. Eisenhower Library (EL), Abilene, KS.

45 "Debriefing of Senior Officers Returning from Field Assignments: Joy K. Vallery," 31, US Army Military History Institute (USAMHI), Carlisle, PA.

46 *Diario de la Costa*, 13 May 1954.

47 *El Tiempo*, 14 May 1954.

48 "Progress Report on Mutual Security Program," 2 July 1954, 450.00, Box 1, Department of State, Bogotá Embassy, Classified General Records, 1953-1955, RG 84, NARA.

49 "Amendment to the Plan of the Government of Colombia and the United States for Their Common Defense," 10 November 1954, Box 32, Army Operations Decimal File, 1954, RG 319, NARA.

50 "Progress Report on Mutual Security Objectives in Colombia," 8 July 1953, 450.00, Box 2, Department of State, Bogotá Embassy, Classified General Records, 1953-1955, RG 84, NARA.

51 "US-Colombian Military Aid Situation," 21 November 1955, 320.10, Box 2, Department of State, Bogotá Embassy, Classified General Records, 1953-1955, RG 84, NARA; and "MAAG Country Statement, Colombia," 26 July 1954, Box 32, Army Operations Decimal File, 1954, RG 319, NARA.

52 "Colombia: Loan of Vessels," 5 April 1960, 7 April 1960, TIAS 4464 [11 UST 1315].

53 "US Military Assistance Advisory Group (MAAG), Colombia Organization and Instructions," 20 December 1957, 320.1, Box 1, Department of State, Bogotá Embassy, General Records, 1956-1958, RG 84; and "Debriefing of Senior Officers Returning from Field Assignments: Joy K. Vallery," 91, USAMHI.

54 "Colombian Use of US Supplies Military Equipment," 19 May 1955, 721.5 MSP/5-1955, Box 3002, Department of State, Decimal File, 1955-1959, RG 59, NARA; and Rempe, "An American Trojan Horse?," 34-64.

55 Murphy to Davis, 5 July 1955, 721.5-MSP/7-555, Box 3002, Department of State, Decimal File, 1955-1959, RG 59, NARA.

56 Mutual Defense Assistance Act, 1954 [68 Stat. 833].

57 "Briefing Paper on Colombia," 1 May 1955, 320.00, Box 4, Department of State, Bogotá Embassy, Classified General Records, 1953-1955, RG 84, NARA.

58 "Debriefing of Senior Officers Returning from Field Assignments: Joy K. Vallery," 51, USAMHI; "Military Aid for Colombia," 18 March 1955, *FRUS*, 1955-1957, VII: 859-860; "Conversation with the Colombian Ambassador," 19 April 1955, 721.5 MSP/4-2955, Box 3002, Department of State, Decimal File, 1955-1959, RG 59, NARA; "Colombia: Military Aid," 721.5-MSP/5-2455, 24 May 1955, Department of State, Decimal File, 1955-1959, RG 59, NARA; "Asistencia Militar Entre la República de Colombia y los Estados Unidos de America," 1 August 1955, Records of the Secretary General, Foreign Ministry, Archives of the President of the Republic, Bogotá, Colombia; and "Military Equipment for Colombia," 26 January 1956, 721.5 MSP/1-2656, Box 3002, Department of State, Decimal Files, 1955-1959, RG 59, NARA.

59 "Mutual Defense Assistance Act, 1954" [68 Stat. 833].

60 "US-Colombian Military Aid Situation," 21 November 1955, 320.10, Box 2, Department of State, Bogotá Embassy, Classified General Records, 1953-1955, RG 84, NARA.

61 "Debriefing of Senior Officers Returning from Field Assignments: Joy K. Vallery," 67, USAMHI.

62 "Export of Napalm Bombs to Colombia to be used to Suppress Rebel Guerrilla Forces," 19 May 1955, 721.5 MSP/5-1955, Department of State, Decimal File, 1955-1959, RG 59, NARA.

- 63 "Current Situation in Colombia," 24 August 1956, 350.00, Box 5, Department of State, Bogotá Embassy, Classified General Records, 1956-1958, RG 84, NARA.
- 64 "Outline Plan of Operations for Colombia," OCB, 24 January 1956, White House Office Files, OCB Central Files, Box 28, Folder "Colombia," EL.
- 65 Key to Schoenfeld, 7 June 1954, 320.00, Box 2, Department of State, Bogotá Embassy, Classified General Records, 1953-1955, RG 84, NARA; "US Air Force Mission to Colombia," 2 May 1956, 721.58/5-256, Box 3002, Department of State, Decimal Files, 1955-1959, RG 59, NARA; Valencia Tovar, "Colombia en la guerra de Corea," 213; Valencia Tovar to Author, 14 January 2001; and "Debriefing of Senior Officers Returning from Field Assignments: Joy K. Vallery," 58, USAMHI.
- 66 "Request for Extension of Services of Colonel Lowry, US Army Corps of Engineers," 24 June 1955, 721.58/6-2455, Box 3002, Department of State, Decimal Files, 1955-1959, RG 59, NARA.
- 67 Ralph Puckett, Jr., and John R. Galvin, "Lancero," *Infantry* 49 (July-September 1959): 21-23; Puckett Interview by Author, 25 April 2002; "Request for Officer to Establish a Ranger-Type School for the Colombian Army," 29 May 1955; and Cheston to Paris, 20 March 1956, Box 2, US Army Missions, General Records, 1952-1964, RG 334, NARA.
- 68 "Medical Specialists in Colombia," 9 March 1954; and Lieutenant Colonel Randall Bryant to Colonel Jaime Polania Puyo, 9 April 1954, Box 32, Army Operations Decimal File, 1954, RG 319, NARA.
- 69 "Military Equipment for Colombia," 19 April 1956, 721.5622/4-1956, Box 3002, Department of State, Decimal Files, 1955-1959, RG 59, NARA.
- 70 "Colombian Air Force," 1957, 320.00, Box 2, Department of State, Bogotá Embassy, Classified General Records, 1956-1958, RG 84, NARA.
- 71 "Meteorological Station," 14 March 1956, 320.10, Box 3, Department of State, Bogotá Embassy, Classified General Records, 1956-1958, RG 84, NARA; and "Weather Station: Cooperative Program on St. Andrews Island," TIAS 3611, [7 UST 2095-2104].
- 72 *El Tiempo*, 21 July 1959.
- 73 US Embassy to the Department of State, 24 June 1959, 721.00/6-2459, Box 4254, Department of State, Decimal Files, 1955-1959, RG 59, NARA.
- 74 "Debriefing of Senior Officers Returning from Field Assignments: Joy K. Vallery," 25-26, USAMHI.





## **Soldiers or Policemen: The Role of Indigenous Constabularies in the Philippines and Haiti**

**Captain Robert Y. Mihara—US Army**

Recent events have made clear the importance of indigenous police forces, or constabularies, to pacification and nation-building operations, separating insurgents from the population and giving substance to local authority. John A. Nagl, in *Learning to Eat Soup with a Knife*, describes constabularies as irreplaceable in establishing the proper security environment for civic action and starving out insurgencies being fought directly by foreign military forces.<sup>1</sup> The Army's 2006 draft counterinsurgency field manual, FM 3-24, devotes a chapter to constabularies and notes their advantages in performing local security tasks, including the successful suppression of banditry and rebellion by the Philippine Constabulary and Scouts. Constabularies are relevant to today's peace operations because they possess unique capabilities as paramilitary police forces. In security sector reform, they represent a nexus of capabilities and effects that impact the three dimensions of reform necessary for enduring change: individual, institutional, and integrative. On the individual level, constabularies provide a vehicle for modifying the attitudes and behaviors of indigenous law enforcement personnel. With outside expertise, they infuse the security sector with enhanced skills. When properly resourced, trained, and applied, constabularies are effective governmental institutions that will remain when the last foreign soldier departs. As indigenous civil agencies, they also integrate government authority and desired norms, such as rule of law, into wider society.<sup>2</sup>

The Philippine Constabulary (1901-1917) and Haitian Gendarmerie (1916-1934) exhibited common shortcomings as constabularies despite strongly contrasting conditions. Both forces failed to accomplish their proper function because their leaders deeply committed them to tasks unrelated to their primary purpose as indigenous police. The Constabulary illustrated the hazards of forging constables into soldiers instead of policemen. The Gendarmerie suffered the consequences of overextending its given capacity for civic action at the expense of maturing itself as a constabulary. Both cases demonstrated the importance of correctly identifying a constabulary's essential mission and remaining committed to it until the organization has matured.

This paper argues two points based on the experience of the Constabulary and Gendarmerie. It asserts that indigenous constabularies ought to perform vital roles such as policing and civic action. It also contends that misconstruing either their

military or their civic capabilities as their primary role ultimately undermines the constabulary's ability to facilitate the creation of stable republics. Constabularies can only function as an army or civil service at the expense of their singular capability to undermine potential insurgencies and decrease the ultimate cost and duration of foreign occupation.

### **The Philippine Constabulary**

After Admiral George Dewey sank the Spanish squadron in Manila Bay on 1 May 1898, President William McKinley sent the first land expeditionary force out from San Francisco under the command of Brigadier General Thomas M. Anderson. Within a year, they would be embroiled in a war many had hoped to avoid. The decision of Filipino nationalists to fight a conventional war with American infantry regiments rapidly proved disastrous for their cause. Even when American officers made questionable decisions, the poor marksmanship and organizational discipline of the Filipino units provided a forgiving learning environment. By 1900, the insurgents had shifted to a guerrilla campaign after a series of military disasters for the Filipino nationalists. By February of that year, American forces had effectively eliminated conventional nationalist forces from the main island of Luzon.

The conventional victory did not prevent brigands and insurrectionists from dominating the towns by intimidation, propaganda, and retaining the cooperation of the landed elite or *principales*. Initially, the Army was slow to recognize that the composition of their enemy had changed from marching battalions into a mix of guerrilla bands, banditry, and fanatical sects. Eventually, the Army successfully responded by dispersing its forces into small garrisons. The units were immersed in the local environment, and their officers became involved in virtually every aspect of local governance. The most successful officers developed counterinsurgency measures that reflected the unique conditions in each town or district. In most provinces, American success at the local level severely constrained the mobility of the guerrillas and allowed mobile US forces to concentrate and meet flare-ups wherever they occurred.<sup>3</sup>

On the Fourth of July 1901, William H. Taft assumed his duties as the first American civil governor of the Philippines and head of the lawmaking Philippine Commission. As chief executive, Taft administered the majority of the provinces. The Army retained only a few turbulent regions under martial law. Conditions in the Philippines had calmed significantly by that year, but pacified provinces still required paramilitary forces to handle small but well-armed and fanatical bands in the volatile rural and remote areas.

The Philippine Commission created the Philippine Constabulary on 18 July 1901 through the passage of Act No. 175, and Army Captain Henry T. Allen was appointed to the position of Chief of Constabulary.<sup>4</sup> The Commission believed that a native “semi-military police” organization, officered and trained by Americans, provided the best option for maintaining the peace and civil order.<sup>5</sup> Luke E. Wright, the vice-governor, had sought to create a constabulary force from the beginning. A Confederate Civil War veteran, Wright lobbied hard to create a force that would reduce the visibility of the Army in the Philippines.<sup>6</sup> Wright viewed the Army’s role as confined to defeating large scale insurgent forces and not in the chasing down of *ladrones*, the bandits and brigands that plagued a large part of the archipelago. He believed that American soldiers were a poor instrument for pacification and shared the civilian consensus that large insurgent forces were an enemy of the past.<sup>7</sup>

Allen and the Commission organized the Philippine Constabulary according to the political boundaries of the islands, with minor changes made out of military expediency. The Philippine Islands were initially divided into four districts in 1901, five districts in 1902, with each district assigned an Assistant Chief of Constabulary. The districts were further sub-divided into provinces, under an American senior inspector. Below that, the provinces consisted of Constabulary stations that were responsible for the various *pueblos*, or towns. Each province was authorized one company of 150 constables, to be recruited from amongst the population. The company was broken down into smaller elements to man the various stations within the province, usually supervised by a Filipino noncommissioned officer, a sergeant or corporal.<sup>8</sup>

The practice of recruiting each province’s company from amongst its population was a conscious divergence from the Spanish constabulary or *Guardia Civil*. Allen and the Commission disparaged Spain’s governance and sought to distance themselves from Spanish methods, dismissing the practical considerations behind them. The Spanish had assigned constables outside of their home areas to ensure that they could be trusted, by reducing opportunities for corruption and political favoritism.<sup>9</sup> Allen expected that forces recruited from their own communities would engender greater respect and gain the voluntary cooperation of the local population. Wallace C. Taylor, district chief for the Third District, concurred with him, noting that “native troops from distant provinces are looked upon more as invaders than supporters of law and order.”<sup>10</sup> Yet, Taylor’s insight and the rationale behind homogenous companies would not prevent Allen from employing Muslim constables in the Christianized province of Samar when violence erupted in 1903.

Organized hastily, the Philippine Constabulary initially settled for training at the local level. Constables made do with what training their officers could provide

on their own even as they were performing actual missions. Taylor protested that a centralized standard training program was essential. He asserted that “if a central school could be established our rapid advancement toward a perfect organization will be assured.”<sup>11</sup> Basic resources were a challenge as well. An initial allocation of ammunition for each constable was twenty-five shotgun rounds per year. In a report to Allen, Taylor begged that the allocation be increased to fifty.<sup>12</sup>

Most Army officers, including those strongly supportive of the Philippine Scouts, were adamantly opposed to the organization of a native constabulary under civilian control. One officer acknowledged the wisdom of native troops but only if they served under Army leadership: “The prevention and suppression of insurrection and disorder should continue to remain in a great measure with the army, aided as largely as possible by the native police . . . and passing entirely under its control wherever and whenever an outbreak is anticipated.”<sup>13</sup> Early columns in the *Army and Navy Journal*, universally praised the Constabulary as an Army contribution. Most officers accepted employing Filipinos in military or constabulary organizations as auxiliaries but not as the leading forces for pacification. William H. Carter, the Army’s commanding officer in the Visayas, shared the parochial view of many Army officers, but he also questioned the logic of employing inexperienced constables in military-style campaigns while his soldiers sat idly in garrisons. Congressional authorization in 1903 for the Constabulary to appropriate Filipino Scouts from the Army further soured professional relations between the Army and Constabulary. Not surprisingly, professional military opinion turned sharply against the Constabulary in 1904 when a mutiny of constables coincided with increased violence in Samar and Leyte: “We have frequently expressed a doubt as to the wisdom of trusting too implicitly in the loyalty and devotion of native troops, particularly the constabulary.” Allen’s insistence on fighting Samar independent of the military and his abrasiveness only deepened Army officers’ disdain for the indigenous police force.<sup>14</sup>

By the time the Constabulary was organized, most in the civilian government believed that the worst days of the Philippine Insurrection were behind them. The capture of the insurrectionary leader Emilio Aguinaldo in March 1901 was widely hailed as a culminating point in the pacification of the Philippine Islands. Whether out of self interest or prescience, the Army expressed strong doubts about transferring authority to the Constabulary, arguing the change premature and a threat to their prerogatives in the Philippines.

## Fighting and Losing in Samar

By August 1901, the first Constabulary detachments were performing their duties, but they remained unevenly trained and disciplined. Many Army officers and enlisted men openly expressed disdain for the native paramilitaries. Major General Adna R. Chaffee, commander of the Philippine Division, doubted the ability of the raw constables to handle the recently pacified provinces. Chaffee urged Taft to bring the Army back into the troubled province of Leyte. Taft, conscious of his sphere of control, heeded Allen's council and declined. Allen believed the continuing unrest in Leyte to be a test of the new Constabulary and, more importantly, a legitimation of civilian rule.<sup>15</sup>

The Philippine Constabulary was created as an alternative to the Army, an insular police force "to prevent and suppress brigandage, insurrection, unlawful assemblies and breaches of the peace." Yet, from late 1902 to 1907, the military campaigns to calm partially pacified provinces transformed the Constabulary into a young and poorly resourced rival army to the Division of the Philippines. The agitations occurred primarily in the provinces of Bulacan, Rizal, Cavite, Leyte and Samar. In order to provide the manpower, Allen routinely siphoned Constabulary detachments from the calmer districts to reinforce the troubled ones. The transfer of manpower became so significant that *ladrones* began to threaten districts previously pacified. By 1905, banditry in Bulacan, Rizal, and Cavite subsided sufficiently for the Secretary of Commerce and Police to declare that the "whole district is in a condition of unprecedented [sic] tranquillity." However, violence in Leyte and Samar continued to threaten the civilian government's claim to governance.<sup>16</sup>

The Constabulary faced a varied enemy in both provinces. After the Philippine War, the islands remained unsettled by religious fanatics and disaffected brigands even as they were transferred to civilian rule. Both groups assumed equal right to the mantle of nationalist revolutionary or *insurrecto*. However, they held no firmer claim on the title than the defeated organizations under Aguinaldo. The brigands, or *ladrones*, expressed the continued grievances that existed between the coastal population and the mountain villagers. The mountain population turned to the *ladrones* for mutual relief from covetous government officials and landowners and for protection from marauding bandits. Religious fanatics injected their fervor into the social discontent. Fusing Catholic doctrine with native animism, a broad movement emerged in Samar and Leyte. Generally known as *pulajanes*, the religious insurrectionists were led by a variety of *Dios-Dios* leaders, recalcitrant revolutionaries, and former criminals. The over arching religious character of the *pulajanes* movement led many contemporary observers to cast it as a remade *Dios-Dios* movement. The latter had provided the fanatical bolomen that bloodied American forces in Samar between 1901 and 1902 during the Philippine War.

However, the *pulajanes* were much more diverse and diffuse. As suggested by their leadership, the movement was not entirely composed of the faithful from within. Several prominent *pulajanes* were outsiders anointed by the spiritual leader of the movement, Pope Pablo, and given his blessing to establish themselves throughout Samar and Leyte for their own ends.<sup>17</sup>

After Army and Marine expeditions forced the surrender of the larger *pulajane* and *ladrone* bands between 1901 and 1902, the region witnessed a gradual resurgence of violence over the subsequent two years.<sup>18</sup> The surrender of prominent *pulajanes* in 1902 had only removed the existing leadership of the movement and broken the momentum of the insurrection. Lesser chiefs remained determined to fight on and drew upon persisting problems on the islands to rebuild the insurrection. New *pulajane* leadership in Samar aggressively increased their ranks and expanded their operations into Leyte. Severe cholera outbreaks in the mountain regions aided their recruiting as death and illness exacerbated existing tensions and enmity between coastal politicians and mountain villagers. The severe epidemic also fueled rumors of American plots to poison the wells.<sup>19</sup> The indications of continued *pulajane* activity were readily dismissed in official reports by Army and Constabulary leaders. The reports maintained a perception of only minor *pulajane* activity by small bands of fewer than a dozen men and arms. Large organized groups of *pulajanes* were considered a problem of the past. In 1902, Chaffee made the strikingly incongruous observation that “Samar is now as quiet and peaceful as the city of San Francisco.”<sup>20</sup> The Philippine Commission also failed to recognize the indications of growing trouble in Samar and Leyte. They discounted the influence of agitators and applied no additional pressure to accelerate Constabulary recruitment in those provinces. *Pulajane* activity had mounted gradually over the previous year, resulting in numerous disastrous or indecisive encounters between small patrols and the insurrectionists.<sup>21</sup> Only the massacre in Samar of thirteen Philippine Scouts serving with the Constabulary in November 1904 brought the situation in Samar to the attention of the Commission. The resurgence of violent activity in the contested provinces would severely test the military and civil pacification efforts in the Philippines.

In Leyte, the Constabulary largely relied upon local constables and municipal police to hunt down the numerous *ladrone* and *pulajane* bands that roamed the province. Allen recognized that a significant hurdle to overcome would be drawing the remote villages into the new insular government. He predicted a long effort requiring patience and “liberal instruction by practical methods.” Isolated village men were particularly susceptible to the fanatical teaching of the numerous “popes” and provided most of the manpower for the *pulajane* bands.<sup>22</sup> The historical enmity between the highland villagers and the peoples of the coastal lowlands

made them ideal recruits.<sup>23</sup> A significant feature of Taylor's approach to the Leyte campaign was his appeal to the loyalties of the indigenous population. Filipino villagers rewarded his efforts by passing on valuable intelligence and providing friendly bases of operation for his constables. Taylor was a fierce jungle fighter, once fighting on after being hit in the jaw with a *pulajane* .45 caliber bullet. Yet, Taylor did not believe he could rely upon force alone to achieve victory. Instead, he took a broad view of the problems in the province and insisted that the solution lay in convincing the locals of their stake in the government and of the authorities' commitment to their security. Seeking to prevent uprisings, Taylor advocated the "establishment of society on so firm a basis that the depredations committed by small bands can not disrupt it and cause the members to break away . . . and join the murderous raids upon neighboring settlements."<sup>24</sup>

While succeeding in Leyte, by July 1903, the Constabulary was overwhelmed by the *pulajanes* raiding the lowland towns of Samar. Their campaigns through Samar had succeeded in drawing blood but failed to terminate religious fanaticism or dangerous sectionalism on the island. Samar reflected the Constabulary's inability to implement Taylor's Leyte policies when so little of their strength was drawn locally. Several of the mountain folk confessed to Taylor that "with bandits on one side and abusive municipal officials on the other there was no one they could look to for protection. They assured him that if the constabulary would establish a post in their midst . . . there would be no more trouble in that section."<sup>25</sup> The slow pace of recruitment in Samar came back to haunt them. Weak on men and resources, the Constabulary could not bring to bear the same force as the Army's Philippine Division. The Constabulary lacked the men to simultaneously conduct substantial expeditions and establish outposts to restrict *pulajane* and *ladrone* movement. It depended heavily on reinforcements recruited from distant provinces. Thus, Constables found themselves fighting an enemy and aiding a populace which commonly viewed them as invaders and outsiders. The advantages of popular support and local knowledge that had mitigated their weaknesses in arms and numbers in other provinces were absent in Samar. With none of its natural advantages, the Constabulary failed to pacify Samar or establish effective civil governance despite Constabulary reinforcements from other provinces and the Philippine Scouts.<sup>26</sup>

The demands of fighting on Samar negatively affected the new neighboring province to the south. As Allen and Taylor grappled with their manpower problem, the Commission had carved Moro Province out of the southern islands of the Sulu Archipelago and Mindanao. Several of Moro's sub-provinces already possessed organized Constabulary detachments. Allen hastily drew upon these largely Muslim Constables to reinforce his effort in Samar. Major General Leonard Wood, Moro's military governor, lamented the loss of the Constables as he pressed his

effort to pacify the province with only his soldiers and the Philippine Scouts. The transfer of Constabulary strength from Moro to Samar and Leyte spread the crisis in manpower to both regions. The absence of a dedicated rural guard of sufficient strength in both Samar and Mindanao contributed to the duration and severity of both campaigns as expeditions chased after elusive bands of men, causing grief to the populace and costing men and materiel.<sup>27</sup>

After six months of effort, Allen conceded defeat and recommended to the Governor-General that the Army's Philippine Division assume the pacification effort on Samar. On 2 June 1905, the Governor-General made the formal request for the Army to pacify those portions of Samar in active unrest with the assistance of the Constabulary. The failure in Samar was prominently reported in June 1905 by the *Army and Navy Journal* who ran the headline "Philippine Constabulary a Failure." The *Manila Sunday Sun* editorial was hardly less caustic: "T'ell with the Constabulary. We will now go to work and establish order in the islands with the only real weapon there is – the American Soldier."<sup>28</sup>

The Philippine Constabulary ultimately proved a poor substitute for the US Army in pacifying the Philippines. The usage of the Constabulary in the pacification campaign in Leyte and Samar squandered its fundamental strength in preventing insurgency, defeating banditry at its source, and furthering the objective of creating republican political and social institutions. Instead of complementing the military campaign, the Constabulary competed with the Army as the predominant pacification force in the post-war Philippines. Rivalry overruled the imperatives of nation-building in dictating the direction of the Constabulary. Allen asserted, and Taft concurred, that the Constabulary needed to fight independently in Samar to fend off criticism from the Army and to protect the prerogative of the Commission. With Taft's approval, Allen focused the Constabulary on pacifying Leyte and Samar and dismissed offers from the Army to assume the mission. As he funneled constables into Samar, constabulary stations in other districts gradually lost the initiative, and indications of reemerging banditry and insurrection appeared in several provinces. The official assertion that it was "now safe to travel practically throughout the archipelago" became increasingly farcical.<sup>29</sup> The inadequacy of the indigenous municipal police in managing local affairs became a routine comment in official reports and correspondence between Constabulary officers: "Municipal Police are almost without exception, inefficient, undisciplined, slouchy and dishonest: little hope can be advanced for their betterment until they are placed on an entirely different footing."<sup>30</sup>

When the Constabulary finally refocused on their civil action role, the municipalities were weak and rife with corruption. The previous commitment of the



Constabulary to a military focus had three main consequences. It squandered the limited resources available to the Philippine Commission by creating a poor duplicate of the US Army instead of an effective paramilitary police force. It left significantly fewer resources for the Commission to create republican institutions at the local level, and it curbed progress being made by constables in civic action.

### *Conducting Civic Action*

Even as constables waged war in Samar and Leyte, the Constabulary assumed aspects of civil government as the Philippine Commission extended its influence. In 1902, it was “called upon to assist in various works somewhat extraneous to the duties laid down for it in the organic act.”<sup>31</sup> In June 1904, the Constabulary established a separate medical division. Within a year, they established seven hospitals and two wards that served constables and the native population. The medical division reportedly received over one thousand cases in its first year.<sup>32</sup> The Constabulary also assumed responsibility for much of the wire services in the Philippines. The Army eagerly passed on the onerous task of maintaining those services. Remarkably, despite distractions, the constables made significant headway in improving and maintaining communications across the islands. From June 1903 to June 1904, the miles of telegraph lines quadrupled, the number of telegraph stations nearly tripled, and the number of working telephones outside of the Manila area more than doubled.<sup>33</sup> Constables also ran the mail in much of the country, the remote areas in particular, with several officers serving as postmasters. Across the islands, they contained epidemic outbreaks and enforced sanitary laws. They guarded jails and escorted prisoners. Their commissary system gained a reputation for efficiency, servicing both the civil administration and themselves.<sup>34</sup> The contribution of the Constabulary went far beyond simple public works projects. Officers learned that their success required guiding the governance of their localities and the reshaping of Filipino society. They understood better than most the challenge of establishing a democratic civil society. However, attempting to fight the military campaigns with fewer resources than the Army stalled their civic efforts and diverted men and pesos. As constables bled fighting the *pulajanes*, the municipal government and police maintained the same culture of graft unfettered.

The same feudal relationships that had governed social relations and bred peasant unrest continued in most places. In some locations, the Constabulary succeeded in gaining the trust and cooperation of the local population and interfering with the exploitation of poor Filipinos. Constables were the only agents capable of intervening on behalf of the peasantry against the elite. Poor Filipinos normally found it impossible to defend themselves against charges from *principales*. Many simply turned to banditry as a response to their desperation.<sup>35</sup> Few Filipinos ini-

tially trusted the Constabulary or the municipal government. Peasants had learned to be wary of the Spanish constabulary, the *Guardia Civil*, which had consistently served the interests of the wealthy. The reinstatement of much of the structure of Spanish rule in the municipalities gave peasants little reason to believe that anything had changed for them. The cumulative effect of exposure to friendly Constabulary patrols and good reports from locals they employed as cargo bearers changed perceptions favorably amongst the peasantry. The change in perception eventually produced tangible results. In one district, an officer noticed a change when increasing numbers of peasants began reporting on bandits.

However, the Constabulary could not effectively conduct pacification and civil action simultaneously. A senior officer asserted that the relative successes of the Constabulary were only the result of heroic efforts by “a few very high grade men who have, during the past few years performed feats of supererogation, *de facto* and also *de jure* by means of persuasion, tact and personal magnetism.” By such effort, many officers made some headway in stemming corruption and implementing forms of social change. One such Constabulary officer was Lieutenant Colonel John R. White, a Briton who arrived in the Philippines in July 1899 serving with the US Fourth Infantry.<sup>36</sup>

White observed that the military organization and focus of the Constabulary produced real costs to the organization and to the American civil administration. The time and resources spent honing military drill and conducting expeditions reduced their proficiency in their core functions of police and civil work. White noted that when a compromise must be made “generally speaking it is the police work which has been sacrificed to the military features, in an effort to emulate the Philippine Scouts.” The petty rivalry with the Scouts and the Army infected the Philippine Commission and the senior leaders of the Constabulary, many of whom were ambitious Regular Army officers. The drift in focus cost the Constabulary where it could have contributed most. The particular demands of both drill and expeditions required a size force that did not fit the specific demands of policing and civil action. Large companies and ad hoc battalions drained the budget and forced wages and subsistence provisions down. White observed that his constables never ate better than his prisoners at Iwahig Penal Colony and that low wages attracted few men of dedication and competence. White complained that on “a muchacho’s, or less than a muchacho’s pay, a muchacho quality is obtained which cannot be taught the duties of a peace officer or depended on for anything but routine and parrot-like work.”<sup>37</sup> The delicate work of constables in towns had to be closely monitored by quality officers and non-commissioned officers, a body of men always in short supply.

Collectively, the Army and Constabulary left the municipalities adrift. While the Army jealously guarded its prerogative where it still governed, Army officers held low estimations of the indigenous ability for self-rule and viewed efforts by the Philippine Commission with suspicion. White strongly resented the attitude regarding civil governance of many Regular Army officers on duty with the Constabulary, writing: "the Military have a damnable manner of taking the whole civil government as a joke."<sup>38</sup> He asserted that the Constabulary needed to play a significant part in maturing the Philippine Government. White believed that "a skilled body of insular officers and men . . . will always, as now, be absolutely necessary to make the delicate adjustment inevitable in provincial and municipal affairs without which outlawry and license would be rampant."<sup>39</sup> The bias of Army officers towards civil rule manifested itself through their career maneuverings and policies. Frequent rotations of officers detailed as local governors or garrison commanders resulted in less familiarity between Army garrisons and their local charges. Stressed by the demands placed on it, the Constabulary could not make up the difference.

White perceived the necessity of a functional division of labor between the Army and Constabulary. The persistence of violence after the Philippine War obscured the divergent nature of the two organizations, as both fought to survive physically and politically. White confessed that the Constabulary bore some of the blame for its errant military focus: "The Constabulary has shown a very natural desire to quell unaided all local disturbances." The rush to the sound of the guns resulted in part from the dominance of Regular Army officers in the Constabulary. Allen made himself a controversial figure by not only assuming the parochial identity of his civilian masters but by his own ambition. As early as 1902, he confessed a ready willingness to hand over his position as chief in favor of a "regular brigadiership."<sup>40</sup>

The efforts that Allen and his successors expended in military campaigning and public works consumed the brief historical moment available to the Constabulary for dramatic change. Enthusiasm for the occupation of the Philippines, never pronounced, waned in the United States as the First World War loomed near. By 1913, the political winds had shifted and Woodrow Wilson, a Democrat, took office as President. The commitment of men and money to challenge the Army's place in the Philippine Islands cost the Constabulary and the Commission a precious five years and drained Philippine coffers of pesos needed badly to reconstruct the municipalities. In effect, Taft undermined his own priorities by subscribing to Allen's logic. He asserted that democracy needed to begin at the town level, drawing a parallel to the American experience. However, Taft subordinated that priority to political considerations. The decision was pragmatic. Yet, it undermined for the

long term a key instrument of Taft's plan for social engineering: the Philippine Constabulary.<sup>41</sup>

### *The Haitian Gendarmerie*

US Marines arrived in Haiti on 28 July 1915 after a violent revolt ended with the dismembering of the Haitian President, Vilbrun Guillaume Sam, and the parading of his remains in the streets of Port-au-Prince. Marines had landed in response to the recurring violence and instability in Haiti thirteen times between 1913 and the July 1915 landing. American expansion into Latin America and the Caribbean during the Spanish-American War renewed national interest in enforcing the Monroe Doctrine. The Taft and Wilson Administrations worried over the possibility of European interventions in Haiti and the threat that foreign control of Haiti represented to American interests, access to the Panama Canal being foremost among them. Sam had forcibly seized power with the aid of a bandit, or *caco*, army early in Wilson's Administration. Wilson worried that the latest coup would trigger action by European creditor nations. He demanded that Sam accede to American management of the Haitian national bank and of naval rights in Haitian ports. Sam's gruesome death provided the pretext for Wilson to impose his plan of responsible government on Haiti by sending a Marine brigade ashore. The intervention proceeded steadily, and the Marines had pacified the countryside by the end of December 1915.

The Marine expeditionary commander, Colonel Littleton W. T. Waller, had anticipated a rapid conclusion of pacification and began organizing for a constabulary force as operations progressed. By the time treaty agreements sanctioned the Haitian Gendarmerie, the organization of the constabulary had already been under way for several months.<sup>42</sup> Waller revealed little patience for the inefficiency and corruption of the Haitian politicians and prescribed an expanded role for the Gendarmerie beyond that of a rural guard. In February 1916, Waller outlined his twenty functions for the gendarmes to perform. The first five were consistent with the treaty; the remaining fifteen indicated Waller's broader vision for the Gendarmerie as a temporary civil service bureaucracy, ranging from sanitation enforcement to census taking.

For this unique police government, Waller called upon Major Smedley D. Butler. Twice awarded the Congressional Medal of Honor, Butler was a singular individual who greatly admired Waller as a soldier and was a ready advocate for native constabularies before serving in Haiti.<sup>43</sup> He had lobbied for the organization of a mounted constabulary while serving in Nicaragua. Arriving in Haiti on 10 August 1915, Butler joined Waller's Marine expeditionary force in time to par-

ticipate in the brief pacification campaign and assumed command of field forces in the northern third of Haiti, serving there until December 1915. His final major action consisted of a one-sided victory at the *caco* stronghold of Fort Rivière.<sup>44</sup> It came several months after Waller had negotiated the surrender of several *caco* generals and was the last major battle of the Marine pacification campaign. Many of the *caco* leaders were enticed into peace deals by offers of positions in the future Gendarmerie. For the Marines and Waller, their major combat role in Haiti was essentially over by late December. Only two weeks after his victory at Fort Rivière, Butler took charge of the Haitian Gendarmerie. Three months later, the Gendarmerie began its duties.<sup>45</sup>

Unlike Allen, Butler did not face either active or passive resistance from the senior military commander during his tenure. From the beginning, the Marine brigade and Gendarmerie operated cooperatively, serving complementary functions. Waller invested strongly in the eventual organization of the constabulary. Butler noted that in selecting the initial cohort of Gendarmerie officers “Colonel Waller . . . contributed the pick of the Marines. I have never found their equal anywhere in the United States service. Many of them learned to speak Creole fluently.” He proudly observed that they worked “like Trojans to lick the Gendarmerie into shape.”<sup>46</sup>

Waller and Butler believed strongly in the necessity of an American-trained constabulary and worked deliberately to shape the guidance from the State Department and legislation from Congress. They immediately dismissed the idea of reforming the existing Haitian police and military. Both had proved impotent during the pattern of coups that had plagued Haiti for years before the American intervention. The Marines decided that to completely sweep away the old military and security forces of Haiti would be the best means to eliminate the vestiges of demoralization and the memory of abuses committed by the standing native forces. Some former members of the Haitian military and police were recruited, but they entered as recruits and were retrained according to the Marine drill regulation.<sup>47</sup>

The United States and Haitian Republic officially created the Haitian Gendarmerie by treaty agreement on 16 September 1915. It was to be “under the direction of the Haitian Government, have supervision and control of arms and ammunition, military supplies, and traffic therein, throughout the country.”<sup>48</sup> The function of the Gendarmerie was further defined in a supplementary agreement the following August. Among other things, it included the former Haitian Navy in the Gendarmerie organization. Most importantly, the agreement specified that the Haitian Gendarmerie would be the sole military and police force in the republic, and it specified that the gendarmes would have “full power to preserve domestic peace,

the security of individual rights, and the full observance of the provisions of the Treaty.”<sup>49</sup> Nowhere in the treaty was a hint of the sweeping duties and functions the gendarmes would perform during the nineteen years of American occupation. The history of the Haitian Gendarmerie resembled that of a civil bureaucracy more than a constabulary.

The training regimen was initially decentralized and of uneven quality. While the gendarme officers were the pick of the Marine brigade, they were severely challenged by the task of training the Gendarmerie from the foundations. The Marines immediately translated their drill manual for training. However, officers discovered: “The principal difficulty was the language, or languages, for while French is the official language of Haiti, Creole is the common language and was universally spoken by the new recruits. The educated class speak French, and all correspondence, text-books and laws were in French.” They quickly adjusted their training methods to simple commands and having trainees imitate their instructors.<sup>50</sup>

With regular pay, good clothing, and meals everyday, the Gendarmerie quickly grew in popularity with the local population. By October 1916, the Gendarmerie had reached full authorized strength. Yet, the gendarmes had not yet earned the full trust of the officers. Issued Krag-Jørgensen rifles, few of them had been trained on proper firing technique by their leadership. The poor marksmanship of the gendarmes was made obvious by their performance in prisoner executions. In one instance, a rifle squad of ten effectives, with the eleventh firing a blank cartridge, managed to hit the prisoner with only one round from thirty feet. The immediate response was to reduce the distance to fifteen feet. Even so, American officers congratulated themselves on their progress: “The Garde in two short years had emerged from a mob of barefoot, ragged peasants, armed with obsolete Russian rifles, into a fairly well equipped and disciplined force of approximately 2,500 officers and men.”<sup>51</sup> Yet, by February 1919, the gendarmes were still not well trained in marksmanship. Gendarme officers remained uncertain of the loyalty of the men to their white American officers. Some units reportedly conducted rifle training, but the decentralized nature of gendarme training made it difficult to gauge how many actually benefited.<sup>52</sup>

### *Conducting Civic Action*

The Gendarmerie assumed a remarkable proportion of the functions of government. Its officers supervised elections. In the constitutional referendum, district commanders were encouraged to hold town meetings to raise awareness and to explain the new constitution and voting. One dispatch even recommended considering an American-style barbecue to increase interest. Gendarme hospitals and

wards provided medical care to the population, as well as the gendarmes. Officers disbursed pay to the civil servants, such as teachers. They enforced sanitary regulations and contained epidemic outbreaks. Many officers were assigned double duty as Communal Advisors in an effort to reduce graft at the local level.

Butler shared Waller's doubts about the efficacy of working through the US-sponsored Haitian government: "This wretched Government absolutely refuses to sign any agreement which may deprive them of their graft." Publicly, he defended the expansiveness of the Gendarmerie as the only viable path to national improvement for the Haitian people: "the Gendarmerie will not be a success without the control of the public utilities." Privately, Butler continued to view public improvements primarily through the lens of military utility and necessity. Obligated by treaty to cooperate with Haiti's president and ministers, Waller and Butler viewed the Gendarmerie as their only assurance that their efforts would bear any fruit for the common Haitian and any promise of an end to the occupation.<sup>53</sup>

The Gendarmerie's civil duties included enforcing the *corvée*, or drafted road labor. Short on funds, the Haitian government could not afford paid labor to improve and maintain a national road network. Marine and Gendarme officers believed that a road network capable of supporting vehicle traffic would be a necessity to create a unified nation and to facilitate Haiti's economy. As in the Philippines, terrain divided the population as effectively as economic class or language. The road project was initially accepted by the Haitian population. The labor crews improved and maintained roads only within their home regions, a basic premise behind the original French colonial system. The logic of the system failed when the work shifted to the remote regions. The mountain areas were too sparsely populated to support the arduous task of carving roads. Consequently, *corvée* laborers were forced to work great distances from their home regions. The gendarmes, themselves former peasants, revealed a persistent capacity to abuse their authority over laborers as well. Their abuse of power was a matter that required constant supervision and laid the foundations for the *caco* resurgence in 1919, revealing a limitation of the organization and its activist agenda.<sup>54</sup>

### **Caco Uprising, 1919-1921**

As civic work progressed, most American officers saw little reason for urgency in accelerating or improving gendarme training from 1915 to 1918. By the end of 1915, all armed resistance from the *caco* insurgency had been quelled, and the Marines retired to consolidated garrisons in Port-au-Prince and Cap-Haitien on the coast as a reserve.<sup>55</sup> In the intervening years, from 1916 to 1918, the gendarmes participated in numerous minor engagements against small groups of bandits, led

by opportunists who tried to claim the mantle of *caco* leadership. Historically, the *cacos* had served as the sponsor for Haitian presidents. When they fell out of favor, the *cacos* would simply lead a coup to install a new president.<sup>56</sup> However, it was not until Charlemagne Peralte emerged from the mountains that the Gendarmerie met its first military test with a potent *caco* leader. One of the first major engagements between gendarmes and Peralte's *caco* bandits was in February 1919 at Boucan Carré.

While serving sentence in Cap-Haitien in late-1918, Peralte escaped from his guards into the mountainous jungle of northern Haiti. He had first appeared to the Gendarmerie when he participated in a raid on 11 October 1917 on the quarters of Captain John L. Doxey, commander for the Hinche district. The attack involved about sixty bandits. The gendarmes rallied and the raid was beaten back. A patrol soon killed the raid's leader and captured his deputy, Marc Ducheine, who surrendered the names of others involved in the raid, including Peralte, who was arrested and sentenced to five years confinement at hard labor. Once free, Peralte rapidly organized a force and immediately began raids in the northern district. The Gendarmerie drafted laborers to expand the nation's road network, and Haitian resentment over the forced labor practice fueled Peralte's bandit recruitment. Riding on pent up animosity, he quickly amassed a force of bandits and a network of supporters and part-time volunteers. As one Marine later recalled, "Soon by the throbbing signal drums the news was being relayed from mountain to mountain in the Department of the North that a mighty general, a second Dessalines, was raising an army that would shortly drive the '*Blancs*' into the sea, and great would be the pillage and loot to the followers of General Charlemagne."<sup>57</sup>

The Marine brigade commander in 1919 was Brigadier General Albertus W. Catlin, who had just returned from the Western Front and "was inclined to believe that the problem was properly one for the Garde to solve, without the help of God and a few marines."<sup>58</sup> Nor did the Gendarmerie leaders take Peralte's activities seriously. The three years of relative peace had led Catlin and others to believe that the worst was long behind them.

Left alone, Peralte was able to build up his contingent into a small army. The force lacked adequate arms and ammunition, but it possessed mobility, physically strong individuals, and the ability to sustain operations on limited resources. Peralte was forced to divide his forces into independent bands, or "detachments," of thirty to fifty men because the countryside could not support large encampments. The groups were further sub-divided into ten to fifteen man "divisions" led by chiefs and sub-chiefs pledged to Peralte. The pace of *caco* expansion was rapid, spreading from its initial origin north of Port-au-Prince southward into the agricul-



turally rich Artibonite Valley. Peralte delegated the southern region to one of his chiefs, Benoit Betraille.

Colonel Walter N. Hill, commanding the Department of Port-au-Prince, believed that the rumors of *caco* activity were credible and responded more readily than the rest of the Gendarmerie leadership. Butler had already departed for Europe, and it was another five months before his replacement arrived. In the meantime, Catlin remained unconvinced that the bandits were a significant threat. Hill followed his instincts and dispatched Major John A. Gray to Mirebalais, the principal town of the Artibonite Valley, to investigate rumors of *caco* activity in that important region. Mirebalais's young garrison commander stated that there was increased *caco* activity in his area, but he had refrained from reporting it because "he was afraid that he might be regarded as a scaremonger."<sup>59</sup>

Native informants reported to the lieutenant that about two hundred *cacos* were encamped at Boucan Carré, about ten miles northwest of Mirebalais under the leadership of Betraille. Gray submitted a request to the Department headquarters in Port-au-Prince for a machine gun to reinforce his position in Mirebalais. Hill responded by leading a detachment of thirty gendarmes, a captain, a lieutenant and the machine gun in tow. Hill was briefed on the native reports upon his arrival and decided to attack the *caco* camp that night.

The Boucan Carré fort was once part of the line of French outposts in the valley. It rested on a stone platform overlooking the Boucan Carré River thirty feet below on a near-vertical drop. Several trails merged within a few yards of the southern wall of the fort, including a main trail leading to Mirebalais. Hill's detachment came upon a "voodoo ceremonial" at around 2 a.m. The *cacos* were dancing about an enormous bonfire. Believing the gendarmes to be inactive, they had not posted any guards. Gray and the garrison commander led two wings of fifteen men each and moved into position on the north and west sides of the fort. The remaining ten gendarmes and the machine gun moved to the south as the ambush element under Hill.

A chance contact with bandits in the tree line by one of the garrison commander's gendarmes tripped off the attack prematurely. The gendarmes opened fire less than two hundred yards from the camp of stunned *cacos*. In the confusion, the gendarmes crossed in front of the machine gun position. Hill, frustrated, held his fire and the attack devolved into a melee with gendarmes firing wildly and *cacos* scattering. Despite the large number of *cacos* in concentration, the number of enemy killed totaled only nineteen. The gendarmes suffered no fatalities. The result of the raid was the scattering of *caco* forces and the lowering of Betraille's

prestige. Still, the ineffectiveness of gendarme fire was galling. “The gendarmes, through no fault of their own, could not employ aimed fire. They fired their Krag carbines from the hip, or held them with hands grasping the comb of the stock and both arms extended, then closed their eyes and pulled the trigger.”<sup>60</sup> Hill’s disappointment was palpable. The number of enemy killed closely matched the number of rounds expended by the officers. Most of the bandits had escaped to fight another day.

The subsequent campaign against Peralte and Betrville from 1919 to 1921 represented an interruption to a history characterized more by civil administration duty than military action. The *cacos* of the time were poorly armed and isolated. The gendarmes were comparatively better disciplined and often courageous when called upon in action: there are many accounts of gendarmes recovering the body of a fallen officer or shielding their officers from *caco* fire.<sup>61</sup> Even so, the Gendarmerie could not control the unrest which they had generated. The Marine brigade garrisoned in Port-au-Prince completed a second pacification campaign, defeating the *cacos* handily, but their victory could not rescue the moribund occupation. The violence of the uprising raised skepticism towards the American mission in Haiti and wounded the political will to continue the effort. The altruistic claims of its proponents appeared questionable after a popular revolt, and investors largely abandoned any hopes of turning a profit in the Haitian Republic. The pacification had left over two thousand Haitian casualties and provoked an extended Congressional inquiry.<sup>62</sup>

By 1921, the historical moment for reforming Haiti had clearly passed. The remaining years consisted of steadily turning over all affairs of government to the Haitians. Mounting political pressure in the US and abroad forced the hand over to operate on an accelerated time line. Gendarme officers rushed to erect the form of a republican constabulary without its substance. Predictably, their belated efforts to politically educate and train an indigenous officer corps failed. Butler overextended his constabulary as a civic action organization during its formative years, from 1916 to 1918. In resurrecting and implementing the *corvée*, Butler also planted the very seeds of uprising shortly before the Haitian constabulary met its first leadership crisis. Few Haitians had been commissioned as Gendarme officers, and many American officers had departed to join the American Expeditionary Force by 1919, including Butler.<sup>63</sup> As a result, the Gendarmerie encountered the Caco Uprising confused and physically unable to quell the turmoil it had created.

## Conclusion

The absence of a competent and legitimate civil authority presented the most significant threat to the occupation and pacification of the Philippines and Haiti. Once military forces supplanted the native government, the constabularies needed to establish civil authority and legitimacy in order to maintain the initiative. The failure to extend civil authority and Constabulary protection in Samar undermined the locals' will to turn against the *pulajanes* living in their midst who exploited them and bloodied American forces for six years. In Haiti, the aggressive approach to civil administration and public works begun under Butler ensured that the *cacos* would remain cut off and impotent. Only the failings of the *corvée* system, another Butler program, led to the increase in bandit activity in 1918 and the open conflict with Peralte and his chiefs from 1919 to 1921.

In both interventions, American forces attended to the essential matter of providing the population with good government but produced mixed results. During the tumultuous transition from pacification to nation-building, constabularies were uniquely positioned to shape the formation of competent indigenous governance and to sever insurgencies from their sustaining logistical and political wells and their transitional role of protecting the development of a stable civil society. Instead, the Constabulary spent most of its history under American leadership maturing as a military organization, focused on putting down major disturbances. In Haiti, the gendarmes implemented a wide range of civil actions but made relatively little progress maturing as a police force. The obsession with large infrastructure projects doomed the Haitian effort by demanding resources the Gendarmerie did not have and the US failed to provide. A report by the American High Commissioner in Haiti, John H. Russell, summed the issue succinctly: "the primary purpose of the Gendarmerie . . . is that of police."<sup>64</sup> Rather than redoubts against authoritarian rule, the Constabulary and Gendarmerie eventually became effective paramilitary forces for the use of any who could command the loyalty of their officers.

Errant focus fatally injured their ability to impact those island nations for the long term. Of the Constabulary, White concluded that it was unable to "fulfill its duties either as an Insular police force or as a military or quasi-military body."<sup>65</sup> The enduring social changes required implicitly by American goals demanded the creation of strong institutions. America's attempt to remake the Philippines and Haiti fell short because its leaders subordinated the establishment of such institutions to the accomplishment of near term pacification victories and public works projects.

Although they became competent counterinsurgency forces, the constabularies' participation in military campaigns represented strategic failures and hampered

their ability to undermine insurgency at its roots and to develop democratic social institutions. American civilian and military leaders failed to understand the indigenous constabularies' vital role as agencies for policing and civic action. They did not sufficiently appreciate that developing local legitimacy and providing security meant more than quelling insurrections or safeguarding American capital investment. Whether as an army or as a shadow government, the constabularies never fulfilled their central duty of anticipating and preventing insurrection or legitimizing civilian rule at the local level. The duty of constabularies was "first to prevent trouble rather than to invite it and prepare to meet it when it comes." In the Philippines and Haiti, American leaders failed to close the gaps between civilian and military mandates.<sup>66</sup> As a consequence, the constabularies were too consumed in corollary missions to fulfill their most important duties.

In order for constabularies to be successful, they must provide intelligence and local law enforcement to anticipate insurrections and violent banditry before they swell beyond the means of civil forces. They must legitimize civil authority by uniformly enforcing laws, stemming corruption, and gaining the trust of the populace. After pacification, constables are also crucial for facilitating every other effort of state-building at the local level. In remote areas, constabularies may be the only agency capable of implementing civil programs. In more populated areas, they must break up oligarchic regimes in the municipalities, fight graft, monitor public works projects, and so on. Such work requires that the occupying power invest significant time and resources into maturing a corps of officers and enlisted constables inculcated with a commitment to the rule of law and professionalism.

## Endnotes

- 1 John A. Nagl, *Learning to Eat Soup with a Knife: Counterinsurgency Lessons from Malaya and Vietnam* (Chicago: University of Chicago Press, 2005), xiv-xv.
- 2 Andrew Rathmell, et al. *Developing Iraq's Security Sector: The Coalition Provisional Authority's Experience* (Santa Monica, CA: RAND National Defense Research Institute, 2005), 7.
- 3 Brian M. Linn, *The US Army and Counterinsurgency in the Philippine War, 1899-1902* (Lawrence, KS: University Press of Kansas, 2000), 16-19, 20-1, 23-6.
- 4 The Army was responsible for governance and pacification of the Philippines until the establishment of the Philippine Commission in 1901. The Army's Philippine Division retained authority in areas declared under martial law. The Constabulary held authority over all areas not under martial law. The only Army units who operated in the Constabulary's areas of responsibility were the Philippine Scouts, consisting of Filipino enlisted and officered by Army regulars.
- 5 Charles Burke Elliott, *The Philippines to the End of the Commission Government: A Study in Tropical Democracy* (Indianapolis: Bobbs-Merrill Company, 1917), 7; George Y. Coats, "The Philippine Constabulary: 1901-1917" (Ph.D. diss., The Ohio State University, 1968), 5.
- 6 Coats, 6; Clayton D. Laurie, "Philippine Constabulary," in *The War of 1898, and US Interventions, 1898-1934: an encyclopedia*, ed. Benjamin Beedle (New York: Garland, 1994), 412; Heath Twichell, Jr., *Allen: The Biography of an Army Officer, 1859-1930* (New Brunswick, NJ: Rutgers University Press, 1974), 118.
- 7 Coats, 4.
- 8 Coats, 18.
- 9 Laurie, 412; Henry T. Allen to W. Cameron Forbes, 1905, Box 8, Henry T. Allen Papers, [hereafter Allen Papers] Library of Congress; Henry T. Allen to William Crozier, 5 February 1905, Allen Papers.
- 10 *Reports of the Philippine Commission* (Washington, D.C.: Government Printing Office, 1905), v. 12, pt. 3, 92.
- 11 *Ibid.*, 93-5.
- 12 *Ibid.*, 96.
- 13 E. J. McClernand, "Our Philippine Problem," *Journal of the Military Service Institution* 29 (November 1901): 331; Coats, 5-6.
- 14 Ronald G. Machoian, *William Harding Carter and the American Army: A Soldier's Story* (Norman, OK: University of Oklahoma Press, 2006), 202-205; *Army and Navy Journal* 41 (13 February 1904): 619. See also (20 February 1904): 592; (2 April 1904): 803; (14 May 1904): 977.
- 15 Henry T. Allen to William H. Taft, 28 March 1902, Box 7, Allen Papers.
- 16 *Reports of the Philippine Commission* (1905), v. 12, pt. 3, 1-2, 29.
- 17 *Army and Navy Journal* 44 (12 January 1907): 528; Brian M. Linn, "The Pulahan Campaign: A Study in US Pacification," *War in History* 6 (January 1999): 45-49; *Pulajanes* is one of multiple spellings found in the sources. This spelling was selected because of its common use by W. C. Taylor of the Third District in his reports. The alternative spellings include *pulajan*, *pulahan*, *polajan*, *polagan*, and *pulahane*; Bolos were the

indigenous weapons frequently used by guerrillas in mass charges. They resembled long knives or machetes; Linn, *The Philippine War, 1899-1902* (Lawrence: University of Kansas Press, 2000), 175-76.

18 The pulajane and ladrone bands had no direct association with the Filipino nationalists that faced the Army and Marines during the Philippine War from 1899-1902. Some former members of the nationalist forces melted into the pulajane and landrone forces, but they did not transmit the cause to these insurrectionary groups.

19 Twitchell, *Allen*, 189; *Reports of the Philippine Commission* (1903), v. 5, pt. 3, 114.

20 *Army and Navy Journal* 40 (15 November 1902): 248.

21 Hurley, *Jungle Patrol*, 189-190, 197.

22 Numerous syncretic groups emerged during the later half of the Philippine War. They were led by numerous self-appointed "popes" who merged aspects of Roman Catholicism with native animism. Often, they would promise their followers immunity from bullets and other such magical blessings.

23 *Reports of the Philippine Commission* (1905), vol. 12, pt. 3, 15-16.

24 Philippine Constabulary, "General Orders No. 38," June 1906, Entry 95, RG 350, National Archives; *Reports of the Philippine Commission* (1905), vol. 12, pt. 3, 92-3.

25 *Reports of the Philippine Commission* (1905), vol. 12, pt. 3, 92-93.

26 Twitchell, *Allen*, 118-20.

27 Leonard Wood to William A. Simpson, 21 November 1904, Box 34, Leonard Wood Papers, Library of Congress; Charles Byer, "Pacifying the Moros: American Military Government in the Southern Philippines, 1899-1913," *Military Review* 85 (May-June 2005): 42-3.

28 Twitchell, *Allen*, 140; *Army and Navy Journal* 43 (1 July 1905): 1187.

29 *Report of the Philippine Commission* (1905), vol. 12, pt. 3, 1.

30 "Monthly Reports on Conditions and Occurrences," 5 May 1903, Box 6, Ax 192, John R. White Papers, [hereafter White Papers] Special Collections, Knight Library, University of Oregon, Eugene, OR.

31 *Reports of the Philippine Commission* (1903), vol. 5, pt. 3, 27.

32 *Idem* (1905), vol. 12, pt. 3, 4.

33 *Ibid.*, 31.

34 *Army and Navy Journal* 40 (10 January 1903): 440; *Idem* (7 November 1903): 244; *Idem* (15 July 1905): 1259; R. A. Duckworth, "The Philippine Constabulary and Its Work" attached to J. R. White's "Memorandum for the Regarding Changes Needed in the Organization of the Constabulary," Box 6, Ax 192, White Papers; Hurley, *Jungle Patrol*, 207.

35 "Philippine Constabulary," Box 6, Ax 192, White Papers.

36 "Memorandum Regarding Changes . . .," Box 6, Ax 192, White Papers.

37 *Ibid.*

38 Letter to Hayson, 22 June 1904, Box 6, Ax 192, White Papers.

39 "Memorandum Regarding Changes . . .," Box 6, Ax 192, White Papers; Diaries 1908-1916, Box 1, Ax 192, White Papers.

40 "Memorandum Regarding Changes . . .," Box 6, Ax 192, White Papers; Henry T. Allen to J. Franklin Bell, 1902, Box 7, Allen Papers.

41 "Memorandum Regarding Changes . . .," Box 6, Ax 192, White Papers; Diaries

1908-1916, Box 1, Ax 192, White Papers.

42 Smedley D. Butler to J. Butler Wright, 15 May 1916, Box 1, Smedley D. Butler Papers, [hereafter Butler Papers] Alfred Gray Research Center, MCU, Quantico, VA; Allen R. Millett, *Semper Fidelis: The History of the United States Marine Corps*, rev. ed. (New York: Free Press, 1991), 180-188.

43 Hans Schmidt, *Maverick Marine: General Smedley D. Butler and the Contradictions of American Military History* (Lexington: The University Press of Kentucky, 1987), 12; Joseph L. Schott, *The Ordeal of Samar: Above and Beyond* (Indianapolis: Bobbs-Merrill, Co., Inc., 1964), 69.

44 Schmidt, *Maverick Marine*, 80, 83; Thomas E. Thrasher, Jr., "The Taking of Fort Rivière," *Marine Corps Gazette* 15 (February 1931): 31-33, 64.

45 Schmidt, *Maverick Marine*, 78, 83; Congress, Senate, Select Committee on Haiti and Santo Domingo, *Hearings Before a Select Committee on Haiti and Santo Domingo*, vol. 1. 67th Congress, 1st session, 5 Aug., . . . 14-16 Nov. 1921, 80. [hereafter Hearings]

46 L. W. T. Waller to John A. Lejeune, 11 June 1916, Reel 3, John A. Lejeune Papers, [hereafter Lejeune Papers] Library of Congress; James H. McCrocklin, *Garde d'Haiti: Twenty Years of Organization and Training by the United States Marine Corps* (Annapolis: United States Naval Institute, 1956), 67.

47 Dion Williams, ed., "The Haitien Gendarmerie," *Marine Corps Gazette* 11 (June 1926): 73, 75.

48 McCrocklin, *Garde d'Haiti*, 241.

49 *Ibid.*, 243.

50 Hearings, 541; Williams, 73-74; McCrocklin, *Garde d'Haiti*, 62; Millett, *Semper Fidelis*, 189.

51 John A. Gray, "Boucan Carré," *Marine Corps Gazette* 16 (November 1932): 28; *Hearings*, 80; The Gendarmerie would later be renamed the Garde d'Haiti. After the American departure, the Garde was renamed in 1949 to the Arme d'Haiti.

52 Gray, 29; McCrocklin, *Garde d'Haiti*, 99-100.

53 L. W. T. Waller to John A. Lejeune, 18 May 1915, Reel 3, Lejeune Papers; Smedley D. Butler to L. W. T. Waller, 25 June 1916, Reel 3, Lejeune Papers; Butler to Lejeune, 13 July 1916, Reel 3, Lejeune Papers; Butler to Lejeune, 13 August 1916, Reel 3, Lejeune Papers.

54 *Hearings*, 560-561; Millett, *Semper Fidelis*, 189-190.

55 Schmidt, *The United States Occupation of Haiti, 1915-1934* (New Brunswick, NJ: Rutgers University Press, 1971), 140.

56 *Hearings*, 518-519.

57 McCrocklin, *Garde d'Haiti*, 103-4; Gray, 28.

58 Gray, 28.

59 *Ibid.*, 28-29.

60 *Ibid.*, 30.

61 *Hearings*, 514-515; McCrocklin, *Garde d'Haiti*, 107.

62 Emily Balch, ed. *Occupied Haiti: Being the report of a Committee of Six disinterested Americans representing organizations exclusively American, who, having personally studied conditions in Haiti in 1926, favor the restoration of the Independence of the Negro Republic* (New York: Negro Universities Press, 1969), 125.

63 Butler to Philippe S. Dartiguenave, 5 March 1918, P.C. 54, Box 2, Butler Papers.

64 "Memorandum by the American High Commissioner," 14 October 1926, Reel 3, Lejeune Papers, Library of Congress.

65 "Memorandum Regarding Changes . . .," Box 6, Ax 192, White Papers.

66 Ibid.; Roxane D. V. Sismanidis, *Police Functions in Peace Operations: Report from a workshop organized by the United States Institute of Peace* (Washington, D.C.: USIP, March 1997), vii, 14.



## Bibliography

### Personal Paper Collections

Special Collections, Knight Library, University of Oregon, Eugene, Oregon.

John R. White Papers.

National Archives, Washington, D.C.

Record Group 350. Records of the Bureau of Insular Affairs.

William H. Taft Papers.

Luke E. Wright Papers.

Library of Congress, Washington, D.C.

Henry T. Allen Papers

John A. Lejeune Papers

John J. Pershing Papers

Leonard Wood Papers

Alfred Gray Research Center, Marine Corps University, Quantico, Virginia

Smedley D. Butler Papers

John H. Russell Papers

### Newspapers

*Army and Navy Journal*. 1901-1907.

### Government Publications

Department of the Army, Headquarters. *Field Manual 3-0, Operations*. Washington, D.C.: HQDA, 14 June 2001.

US War Department. *Report of the Philippine Commission, vol. 10, pt. 3*. Washington, D.C.: Government Printing Office, 1902.

\_\_\_\_\_. *Report of the Philippine Commission, vol. 5, pt. 3*. Washington, D.C.: Government Printing Office, 1903.

\_\_\_\_\_. *Report of the Philippine Commission, vol. 12, pt. 3*. Washington, D.C.: Government Printing Office, 1904.

\_\_\_\_\_. *Report of the Philippine Commission, vol. 11, pt. 3.* Washington, D.C.: Government Printing Office, 1905.

\_\_\_\_\_. *Report of the Philippine Commission, vol. 8, pt. 3.* Washington, D.C.: Government Printing Office, 1907.

United States. Congress. House. Committee on Military Affairs. Subcommittee No. 5. *Philippine Constabulary Hearings on H.R. 9496.* 70th Congress, 1st session, 27 Feb. 1928.

United States. Congress. Senate. Select Committee on Haiti and Santo Domingo. *Inquiry into Occupation and Administration of Haiti and Santo Domingo. Vol. 1 Hearings Before the United States Senate Select Committee on Haiti and Santo Domingo.* 67th Congress, 1st and 2nd sessions, 5 Aug., 4-5, 11-12, 17-20, 24, 26-27, 31 Oct., 3, 7-10, 14-16 Nov. 1921.

United States. Congress. Senate. Select Committee on Haiti and Santo Domingo. *Inquiry into Occupation and Administration of Haiti and Santo Domingo. Vol. 2 Hearings Before the United States Senate Select Committee on Haiti and Santo Domingo.* 67th Congress, 2nd session, 29-30 Nov., 1-2, 5-6, 9-10, 12-15 Dec. 1921, 7-8 Feb., 8-10, 15-16 Mar., 15-16 Jun. 1922.

US Congress. House. Committee on Government Reform. Subcommittee on National Security, Emerging Threats and International Relations. *Building Iraqi Security Forces.* Report prepared by Peter Khalil, 109th Congress, 1st session, 2005.

## **Books**

Balch, Emily Greene, ed. *Occupied Haiti: Being the report of a Committee of Six disinterested Americans representing organizations exclusively American, who, having personally studied conditions in Haiti in 1926, favor the restoration of the Independence of the Negro Republic.* New York: Negro Universities Press, 1969.

Bickel, Keith B. *Mars Learning: the Marine Corps Development of Small Wars Doctrine, 1915-1940.* Boulder: Westview Press, 2001.

Birtle, Andrew J. *US Army Counterinsurgency and Contingency Operations Doctrine, 1860-1941.* Washington, D.C.: Center of Military History, 2003.

Beedle, Benjamin, ed. *The War of 1898 and US Interventions, 1898-1934: an Encyclopedia.* New York: Garland, 1994.

Cox, Isaac J. *Nicaragua and the United States, 1909-1927.* World Peace Foundation Pamphlets, vol 10, no. 7. (Boston: World Peace Foundation, 1927), 706-887.

Elliott, Charles B. *The Philippines to the end of the Commission Government*. Indianapolis: Bobbs-Merrill, 1917.

Forbes, W. Cameron. *The Philippine Islands*. Boston: Houghton Mifflin Co., 1928.

Goldwert, Marvin. *The Constabulary in the Dominican Republic and Nicaragua: Progeny and Legacy of United States Intervention*. Gainesville: University of Florida Press, 1962.

Graff, Henry F., ed. *American Imperialism and the Philippine Insurrection: Testimony taken from Hearings on Affairs in the Philippine Islands before the Senate Committee on the Philippines -- 1902*. Boston: Little Brown and Company, 1969.

Griffith, Samuel B. II, trans. *On Guerilla Warfare: Mao Tse-tung*. Urbana: University of Illinois Press, 2000.

Hosmer, Stephen T. *The Army's Role in Counterinsurgency and Insurgency*. Santa Monica, CA: RAND Corporation, 1990.

Hurley, Vic. *Jungle Patrol: the Story of the Philippine Constabulary*. New York: E.P. Dutton, 1938.

Machoian, Ronald G. *William Harding Carter and the American Army: A Soldier's Story*. Norman, OK: University of Oklahoma Press, 2006.

Linn, Brian M. *The US Army and Counterinsurgency in the Philippine War, 1899-1902*. Chapel Hill: University of North Carolina Press, 1989.

\_\_\_\_\_. *The Philippine War, 1899-1902*. Lawrence: University of Kansas Press, 2000.

May, Glenn A. *Social Engineering in the Philippines: The Aims, Execution, and Impact of American Colonial Policy, 1900-1913*. Westport, CT: Greenwood Press, 1980.

McCrocklin, James. *Garde d'Haiti, 1915-1934: Twenty Years of Organization and Training by the United States Marine Corps*. Annapolis: United States Naval Institute, 1956.

Millett, Alan R. *Semper Fidelis: The History of the United States Marine Corps*, rev. ed. *The MacMillan Wars of the United States*, Louis Morton ed. New York: The Free Press, 1991.

Millsbaugh, Arthur C. *Haiti Under American Control, 1915-1930*. Westport, CT: Negro Universities Press, 1970.

- Nagl, John A. *Learning to Eat Soup with a Knife: Counterinsurgency Lessons from Malaya and Vietnam*. Chicago: University of Chicago Press, 2005.
- Parker, Guy J. *Notes on Non-military Measures in Control of Insurgency*. Santa Monica, CA: RAND Corporation, 1962. P-2642.
- Philippines Constabulary Bureau. *General Orders*. Manila, 1904-1909.
- Rathmell, Andrew, and Olga Olikier, Terrence K. Kelly, David Brannan, Keith Crane. *Developing Iraq's Security Sector: The Coalition Provisional Authority's Experience*. Santa Monica, CA: RAND Corporation, 2005.
- Renda, Mary A. *Taking Haiti: Military Occupation and the Culture of US Imperialism, 1915-1940*. Chapel Hill: University of North Carolina Press, 2001.
- Schmidt, Hans. *Maverick Marine: General Smedley D. Butler and the Contradictions of American Military History*. Lexington: The University Press of Kentucky, 1987.
- Schott, Joseph L. *The Ordeal of Samar*. Indianapolis: The Bobbs-Merrill Company, Inc., 1964.
- Sismanidis, Roxane D. V. *Police Functions in Peace Operations: Report from a workshop organized by the United States Institute of Peace*. Washington, D.C.: USIP, March 1997.
- Taylor, John R. M., ed. *Philippine Insurgent Records 1896-1901: with associated records of the US War Department, 1900-1906*. Washington, D.C.: National Archives, 1958.
- Twichell, Heath. *Allen: A Biography of an Army Officer, 1859-1930*. New Brunswick, NJ: Rutgers University Press, 1974.
- Wade, Norman M. *The Operations SMARTbook: Guide to FM 3-0 Full Spectrum Operations and the Battlefield Operating Systems*, 3d. Rev. Ed. Lakeland, FL: The Lightning Press, 2002.
- Williams, D. R. *The United States and the Philippines*. Garden City, NY: Doubleday, Page & Co., 1924.
- Worcester, Dean C. *The Philippines Past and Present*, vol. 1. New York: The MacMillan Company, 1914.

## Articles

- Anderson, Thomas M. "Our Rule in the Philippines." *The North American Review* 170 (February 1900): 272-284.

- Bride, Frank L. "The Gendarmerie d'Haiti." *The Marine Corps Gazette* 3 (December 1918): 295-299.
- Byler, Charles. "Pacifying the Moros: American Military Government in the Southern Philippines, 1899-1913." *Military Review* 85 (May-June 2005): 41-45.
- Cordesman, Anthony H. *Testimony before the Subcommittee on National Security, Emerging Threats, and International Relations; Committee on Government Reform; US House of Representatives: Iraqi Forces*. Washington, D.C.: Center for Strategic and International Studies, 2005.
- \_\_\_\_\_. *Strengthening Iraqi Military and Security Forces*. Washington, D.C.: Center for Strategic and International Studies, 2005.
- Davis, Henry C. "Indoctrination of Latin-American Service." *The Marine Corps Gazette* 5 (June 1920): 154-161.
- Etherington, Mark. Interview by Terry Gross. *Fresh Air*. NPR (11 January 2006).
- Fellows, Edward A. "Training Native Troops in Santo Domingo." *The Marine Corps Gazette* 8 (December 1923): 215-233.
- Johnston, William H. "Employment of Philippine Scouts in War," *Journal of the Military Service Institution* 38 (January-February 1906): 67-77.
- Keyser, Ralph Stover. "Constabularies for Latin America." *The Marine Corps Gazette* 11 (June 1926): 89-97.
- Kilmartin, Robert C. "Indoctrination in Santo Domingo." *The Marine Corps Gazette* 7 (December 1922): 377-386.
- Gray, John A. "Boucan Carre." *The Marine Corps Gazette* 16 (November 1931): 28-32.
- \_\_\_\_\_. "Cul de Sac." *The Marine Corps Gazette* 16 (February 1932): 41-44.
- Linn, Brian M. "The Pulahan Campaign: A Study in US Pacification." *War in History* 6 (January 1999): 45-71.
- Mabini, Apolinario. "A Filipino Appeal to the People of the United States." *The North American Review* 170 (January 1900): 54-60.
- McClermand, E. J. "Our Philippine Problem." *Journal of the Military Service Institution* 29 (November 1901): 327-332.

Miska, Steven M. "Growing the Iraqi Security Forces." *Military Review* 85 (July-August 2005): 64-69.

Rhodes, Charles D. "The Utilization of Native Troops in Our Foreign Possessions," *Journal of the Military Service Institution* 30 (January 1902): 1-22.

Thrasher, Thomas E. Jr. "The Taking of Fort Riviere." *The Marine Corps Gazette* 15 (February 1931): 31-33, 64.

Williams, Charles F. "La Guardia Nacional Dominicana." *The Marine Corps Gazette* 3 (September 1918): 195-199.

Williams, Dion. "The Haitien Gendarmerie." *The Marine Corps Gazette* 11 (June 1926): 73-81.

### **Dissertations**

Coats, George Y. "The Philippine Constabulary: 1901-1917." Ph.D. diss., The Ohio State University, 1968.

Woolard, James R. "The Philippine Scouts: The Development of America's Colonial Army." Ph.D. diss., The Ohio State University, 1975.

## **The US Advisory Effort in El Salvador**

**Dr. Lawrence E. Cline—American Military University**

The US security assistance effort to El Salvador represented what was probably the largest US security commitment in an area of armed conflict during the period between the end of the Vietnam War and the beginning of Desert Shield/Desert Storm. The US poured in somewhere around six billion dollars to El Salvador, with about one billion of this being for military assistance. Despite this financial, material, and diplomatic support, the number of US personnel actually in country in El Salvador remained miniscule. Formally assigned advisors to the El Salvador Armed Forces (ESAF) were capped at a maximum strength of 55, with various support personnel typically bringing the numbers of US military assigned up to just slightly over 100 in total.<sup>1</sup>

US support efforts to El Salvador over about a twelve year period did not result in a 'victory' over the opposition FMLN guerrilla movement. Given the normal trajectories of counterinsurgency and the rather complicated environment of El Salvador, a clear-cut victory by the government probably was not a realistic prospect, even though this was occasionally given as US government policy. The actual results, however—a reasonably stable, democratic government that has become a close ally of the US—suggest that the effort succeeded in its longer term strategic aspects. As such, the record of the US security assistance program for El Salvador, and particularly the role of the advisory effort, deserves examination for lessons that can be applied to other areas.

### **The Environment**

Only a brief summary of the security environment in El Salvador will be provided here. The country had been ruled by oligarchs during most of its history, and in the late 1970's by a military junta obligated to the oligarchs. In 1979, a fresh coup succeeded in removing the previous military regime, with promises of serving the populace rather than the oligarchs. 1979 of course also marked the success of the Sandinista movement in Nicaragua.

Left-wing unrest and agitation had begun to become prominent in the 1960's. The various anti-government radical movements were, however, disjointed and uncoordinated. It was not until the five major insurgent groups formed the FMLN (at Fidel Castro's urging) that they became a relatively cohesive insurgent force, albeit one that continued to suffer from some fissures between its component groups. The

FMLN launched its “final offensive” in 1981. Despite some initial successes, the insurgent attacks were beaten back by the ESAF, and the war assumed a more traditional form of guerrilla warfare. In addition to internal logistics chains (including seizures of weapons from the ESAF), the FMLN received relatively significant support from Cuba and Nicaragua.<sup>2</sup>

At the beginning of the conflict, the ESAF was almost totally unprepared for counterinsurgency. Its forces were small, poorly trained, focused on conventional warfare, and were largely a ‘garrison force.’ During the course of the war, the ESAF was expanded from 15,000 to 56,000, and began increasingly to stress counterinsurgency as its primary mission. Particularly at the beginning of the war, its human rights record was abysmal (with more discussion of human rights later in the paper). Corruption was widespread in the early 1980’s, and the *tanda* system in which officers tended to owe more allegiance to the fellow members of their graduating class from the Military Academy than they did to the ESAF overall continued to plague all the security forces. Regardless of their abilities, officers generally were promoted together as part of their *tanda*, meaning that bad officers would be brought along with the good ones. An additional complicating factor was that the ESAF contained not only the army, navy, and air force, but also the principal police and other security forces, with officers at times coming up through the ranks by alternating police and army assignments.

During the early period of the Civil War, US officials were very concerned about the possible failure of the Salvadoran government to survive. In 1979, a confidential US Embassy cable stated that “If confronted with a Nicaragua-type situation the El Salvadoran military establishment could easily collapse in four to six weeks.”<sup>3</sup> At the end of 1982 or beginning of 1983, the SOUTHCOM Commander reported to the Pentagon that he “was afraid that the whole thing was about to go down the tubes.”<sup>4</sup> Even as late as the end of 1983, Ambassador Thomas Pickering later noted that “...we wondered whether we would make it through the next two or three months...”<sup>5</sup>

### **The US Security Assistance Effort at the Political and Strategic Levels**

Up until about 1982, the US security assistance program largely focused on building a conventional force. In a sense, turning around the ESAF so that it would be an effective counterinsurgency force also meant turning around earlier US efforts.<sup>6</sup> It should be noted that at least some outside observers argued as late as 1990 that the US was still continuing to push conventional operations and mindset on the Salvadorans.<sup>7</sup> Observations on the ground, however, would suggest the op-



posite: that the US efforts were in fact directed toward building a force skilled in counterinsurgency.

Two documents became significant in planning US support. The 1982 Woerner Report, named after General Fred Woerner, became the template for both Salvadoran military planning for its counterinsurgency requirements and for US military assistance in support of these missions.<sup>8</sup> A key reason for Salvadoran acceptance of the report's recommendations was that the Salvadorans themselves—in the form of President Jose Napoleon Duarte—requested that the US provide a fresh eye at the military situation rather than simply adding advisors to the effort.<sup>9</sup> In response, SOUTHCOM provided General Woerner and a small team to conduct an assessment and recommendations to the Salvadoran government. As he noted later, although it would have been preferable to have developed a true national strategy on which a later national military strategy could be based, he limited the scope of his mission to a national military strategy.<sup>10</sup> The report also included specific steps the US could take to support this national military strategy.

The second document was the 1984 National Bipartisan Commission on Central America Report, commonly known as the Kissinger Commission Report. This report was much broader than the Woerner Report, focusing on the larger political and social tools necessary for success. This document stressed the necessity for implementing “human development programs”; building government legitimacy by social and economic changes; establishing democratic legitimacy by holding free and fair elections; and ending human rights abuses. Importantly, it also established the principle of US “conditionality.” This stated that future US military aid “be contingent upon the Salvadoran government’s demonstrated progress” on the above goals.<sup>11</sup> This caveat on US support being conditional on Salvadoran behavior became a ‘hammer’ to be used to try to coax the Salvadoran government and military to improve their behavior and performance, although as noted below, some have argued that its impact was in fact minimal.

The overall advisory and security assistance program was plagued by domestic US political differences and significant political opposition to the effort. From the start of US involvement, fears were expressed that the deployment of advisors would lead to ‘another Vietnam.’<sup>12</sup> These problems commonly were exacerbated by public ignorance of what actually was being done by the US in El Salvador; for example, early in the war, charges were leveled that the US was illegally “controlling” the fighting by assigning advisors to the Estado Mayor (General Staff).<sup>13</sup>

The skepticism and downright opposition plagued the assistance effort at the political level. Both President Reagan and President Bush had to expend consid-

erable political capital to continue the security assistance program. At the early stage of the program, the Administration developed the number of 55 advisors as the ceiling in order to assuage Congressional fears of a Vietnam redux. This figure seemingly had little or nothing to do with the actual requirements on the ground, but was much more what would be politically palatable.

Uncertainties as to financing continued to plague the support system, particularly in the early period. Virtually every Congressional vote on appropriations and authorizations became contentious. One former MILGROUP commander noted that during his tenure, all the funds available had been expended by the end of July, with only hopes and expectations of receiving an additional 25 million dollars.<sup>14</sup> One result at the tactical level was that many Salvadoran army units would 'stash' ammunition and supplies in case that US funding for replacement stocks did not materialize in time.

At the bureaucratic level, there reportedly were some coordination and cooperation problems between the US Embassy in San Salvador and US Southern Command (SOUTHCOM) then based in Panama. This apparently was due at least in part because of larger issues between the State Department and SOUTHCOM.<sup>15</sup> To some degree, the MILGROUP seemed to get caught in the middle of some of these early bureaucratic conflicts. Most of the public comments on this coordination problem were from the earlier period of US involvement, with later comments on the Embassy-SOUTHCOM relationship being much more positive.<sup>16</sup>

At the macro level, the US security assistance program remained very shaky in terms of long term commitment. General John Galvin provided a very useful and accurate assessment of the overall program:

The Salvadoran armed forces felt that we came to their rescue. At the same time we are viewed as unpredictable, unreliable allies who cannot find it in our hearts and minds and pocketbooks to sustain anything that we do for very long. So that, in the Salvadoran military thinking, there was always the question of how much longer can we persuade the United States to continue helping us, or when will the day come when once again we are on our own...the realization that it could end at any time, that the Congress might vote it out, made it extremely difficult to plan ahead.<sup>17</sup>

Other senior officials noted that beyond the financial issue, there were significant gaps in developing, coordinating, and maintaining a consistent US national strategy toward El Salvador.<sup>18</sup>

### **The 55 Man Limit: The Negatives**

The 55 man limit on advisors imposed by Congress created a number of practical difficulties in maintaining the desired level of training. Dean Hinton, the US Ambassador in El Salvador from 1982 to 1983, detailed the underlying issues:

Part of the problem...arose from the congressional limit on the number of American trainers you could have in El Salvador. Congress wouldn't budge...This was a problem in the conduct of almost all operations. Sit there and it was like a football team that has 45 or 55 players, and you must shuffle them in and out (of El Salvador) of the lineup. There were days when we had to stay within the ceiling, to send trainers out so we could get people in, because we needed even more. Peculiar way to run a ball game.<sup>19</sup>

One MILGROUP commander noted that he was unable to bring in enough trainers at one time to fully train a battalion because of not having enough spaces within the 55 man limit.<sup>20</sup> As a result, he was forced to train one Salvadoran battalion in the US. He noted that "It cost \$8,000,000 to train the BELLOSO Battalion in the United States. I could have trained and equipped six to eight battalions for the price of one if we could have done it in-country."<sup>21</sup> There also were issues as to how and in what subjects individual Salvadoran officers were trained in the US.<sup>22</sup>

More generally, there simply was not enough training—whether inside or outside El Salvador—for some critical skills. Noncommissioned officer training remained weak; largely because of (the rather common throughout Latin American) attitude that noncommissioned officers were not terribly important and that field leadership should be in the hands of officers.<sup>23</sup> This was exacerbated by the inability to train a quickly expanded junior officer corps quickly enough. The problem also extended to a significantly expanded Salvadoran air force, in which there were only 70 pilots for 135 aircraft as late as 1987.<sup>24</sup>

There also were some bureaucratic roadblocks in the US training system that in many ways were highlighted by the limited number of trainers and advisors inside El Salvador. James Corum noted several of these in connection with the Salvadoran Air Force:

The bureaucratic requirements of the US military system also got in the way of a timely response to El Salvador's situation. The requirement that foreign pilots training with the US Air Force first take a six-month language course slowed down the pilot training program for the Salvadorans. Finally, when the shortage of helicopter pilots became truly severe, the US Army conducted a one-time effort at Fort Rucker, Alabama, to train Salvadoran pilots with Spanish-speaking

flight instructors... For various reasons, US military schools were slow to create the courses that the Salvadoran military urgently needed. For example, the US-run Inter-American Air Force Academy in Panama only initiated an advanced training course for the A-37B in 1985, three years after that model aircraft had been supplied to the FAS.<sup>25</sup>

Garnering support from other countries for training and equipping the Salvadoran military never was terribly successful. Venezuelan Special Forces teams trained two Salvadoran battalions. The major impact of regional countries in supporting the ESAF training efforts was in providing an area in which US personnel could train Salvadorans while not exceeding the 55 man limit in country. Both Panama and Honduras permitted such training bases inside their countries. Even this limited support became contentious, with Honduras closing the Regional Military Training Center (which essentially was a facility for training the ESAF) in 1985.

### **The 55 Man Limit: The Positives**

Much of the attention at the time on the Congressionally-imposed limitations on the number of advisors focused on the negatives. In retrospect, however, it may well actually have had more advantages. Colonel James Steele, MILGROUP Commander from 1984 to 1986, noted some of the key benefits of the small number of advisors:

Nobody has cursed the 55-man limit more than I probably have in the last two and a half years, but I just have to tell you that doing it with a low US profile is the only way to go. If you don't, you immediately get yourself into trouble, because there is a tendency for Americans to want to do things quickly, to do them efficiently - and the third step in that process is to do it yourself. If you take that third step here, you have lost the battle...Keep in mind that when you try to do it yourself, you're imposing what is going inevitably to be viewed as a Gringo solution. When you do that, you assume the responsibility to make it work. They have a ready-made excuse if they don't like it or don't want to support it...<sup>26</sup>

Beyond the issues he notes, the limited number of advisors had some larger political advantages. Together with restrictions on the operational deployments of the advisors, the small numbers also meant that the prospect of large-scale American casualties was reduced significantly. Given the unpopularity of the war in some circles, major US casualties likely would have increased domestic opposition, and convinced some Congress members that they should withdraw US forces. During most of the war, US operations in a sense were simply not particularly noticed by much of the US public. In a domestic political sense, this likely was to the long-term advantage of the security assistance operation.

## **Operational Issues for the Advisors**

The limited number of advisors in country meant that their preparation and performance were particularly critical. A Salvadoran brigade commander offered an interesting perspective on what he looked for in US advisors: “I began looking for better advice from the North Americans. Specifically, I asked them to give me sergeants or captains but no colonels – the colonels who were here spent their time playing mini-golf and swimming in the pool. Sergeants and captains are people to train troops.”<sup>27</sup> With the limited pool of advisors, how well each performed and their relationships with their Salvadoran counterparts essentially drove individual success. As one former advisor noted, “One reason [for limited results] is that our work was local and personalized. If the unit commander, XO, or 3 liked you, you got a lot more done.”<sup>28</sup>

A number of restrictions were placed on the activities of the US advisors. In the early period, their weaponry was circumscribed, with only very minimal arms to be carried, but these restrictions later were loosened. Throughout the war, advisors were prohibited from accompanying ESAF units on field operations. There certainly was some chafing by US advisors, particularly in the early days, over the restrictions placed on them. In at least two cases, advisors were relieved for violating these rules; in one episode, an advisor was wounded as a result of flying on a helicopter on an operational mission.<sup>29</sup> The restrictions probably did have some adverse impact on short-term support since the advisors were unable to observe their assigned ESAF units in the field to assess their actual operations and were not able to provide immediate advice and support. As with the strength limitations, however, the operational restrictions almost certainly helped minimize political complications.

Several observers have noted gaps in training for the advisors. This might have been particularly critical for the Military Intelligence advisors, who likely required even more background on the Salvadoran political and security environment than did other advisors. One former MI advisor noted four training weaknesses: “deployment experience in Latin America; knowledge of the political situation; knowledge of the history of the country and the conflict; in some cases, language qualifications.”<sup>30</sup>

It is unlikely that pre-deployment training for the battalion and brigade advisors was as much a problem, since they came from the 7th Special Forces Group and already had language training and the other skills required for immediate effectiveness. Training for advisors in other positions was more problematical, however. At least in 1988-1989, training essentially consisted of a six month training course in Spanish at Defense Language Institute (if required), a brief course at the

Special Warfare Center focusing on personal protection, and a short program at the Defense Institute of Security Assistance Management, which dealt predominantly with the bureaucracy involved in security assistance cases.

The quality of US personnel selected as advisors remains somewhat a contentious issue. Ambassador Thomas Pickering argued that both the personnel and the systems for assigning them were “top notch.”<sup>31</sup> Others have suggested that the US personnel were not always the best available. One Marine Corps officer argued that:

All too often the selection criteria for duty in El Salvador is at the convenience of the personnel system. Many priorities are put upon the system, but in the end the person selected is a result of who is available for a PCS move. The Marine Corps does not have a system to screen or train personnel for such an assignment. If the Marine speaks the language, he will be found qualified for the assignment.<sup>32</sup>

It is probably fair to say that the Special Forces assigned to El Salvador were of high quality, both because of their background and training, and because many served multiple tours. It is much more difficult to assess the overall quality of the other advisors. There is little evidence to suggest that the overall military personnel system (to include the promotion system) gave any special consideration for those selected as advisors. Many of those who served as advisors were volunteers, which probably led to some self-selection of those who were motivated and desirous of the assignment, but the stress placed by the various personnel commands on identifying and assigning the absolute best remains questionable.

As with Vietnam, the one-year tour for most advisors probably led to difficulties in continuity of support.<sup>33</sup> Ambassador Pickering noted the specific problems involved:

The other thing that I fought like hell for, and had an enormous problem with, was longer tours for military people. I felt that we were constantly running people through there who had to relearn. The one-year tour did not become effective for four to six months, and it was a tragedy that we did this. We didn't have that many people who wanted to come, first, and secondly, we didn't have that many people who could pick up as rapidly on what their predecessors had done, so in a sense we were constantly relearning old lessons.<sup>34</sup>

The issue was addressed in part by establishing two-year tours for certain critical positions, but most remained one-year tours. It is difficult to see how this problem could have been easily resolved. Although generally viewed as a ‘plum’

assignment by most Special Forces soldiers, most of the rest of the military seemed to look at advisory duty in El Salvador as (in the infamous phrase) “out of the mainstream.” As such, it might have been even more difficult for the personnel systems to have provided qualified personnel.

### **The Advisory Effort and Human Rights**

The human rights performance of the ESAF also remained a major focus of the US advisory effort. Colonel James J. Steele, MILGROUPE Commander from 1984 to 1986, expressed the overall situation in terms of professionalization:

When we say professionalize, I’m talking about developing, within the military, the respect for the human rights of its citizens, to help protect the democratic process, and so on. I think...there’s been some pretty significant progress. If you look at this military and say, “Okay, have we really changed their attitude towards democracy, their role in the society, or have we just levered them into a behavioral change?” The answer is, at this point, it’s too early to tell. It’s going to take a while...<sup>35</sup>

The level of the US Administration’s concern for improving the human rights performance of the Salvadoran military also played a key role. Vice President Bush’s visit in December 1983 helped emphasize the exhortations of the advisors. According to General Adolfo Blandon, later to be Chief of Staff of the ESAF, “We all understood that US support for this war...could only be continued if we had a comprehensive program and understood what it meant...to respect the human being’s integrity and to respect people’s property.”<sup>36</sup> Likewise, in March 1989, Vice President Quayle made a similar demarche to the Salvadoran military, threatening a cutoff of aid if human rights efforts were not improved. As one author notes, however, as the US was emphasizing the importance of supporting the ESAF to preclude an FMLN victory, it was threatening to cut off aid. Just how seriously the Salvadorans took these threats may be subject to some question.<sup>37</sup>

Clearly, even with the emphasis on human rights with the Salvadoran security forces, abuses continued. Perhaps the most egregious example of the lack of complete success of these efforts was the 1989 murder of the six Jesuits in San Salvador during the last major FMLN offensive. For many observers, this incident exemplified the lack of progress in human rights. In fairness, however, there did in fact seem to be progress in this area. In 1980, there were an average of 610 murders a month; by 1987, this had dropped to 23 murders a month.<sup>38</sup>

Although necessary from both a political and larger humanitarian viewpoint, the continued emphasis by the US at both political and operational levels probably impacted on the day to day relationships between the advisors and their counterparts, and at the higher political levels. As one author notes:

Neither the United States nor El Salvador are in any way happy with the pressure that America has had to bring to bear on the Salvadoran government and armed forces to achieve the limited progress in human rights. The military and significant elements in Salvadoran society have continually been outraged at what truly amounts to unacceptable American interference in their internal affairs.<sup>39</sup>

At the working level, some of the difficulties could be alleviated by putting the human rights issues in terms of practicality: prisoners should not be summarily executed because they might be the source of valuable intelligence; civilians should not be abused since they would then become anti-government and anti-military; if the military committed human rights abuses, Congress would cut off funding; and the like. Nevertheless, the human rights dimension of the advisory effort probably did create some barriers at the operational level, even though necessary.

## **The Results**

Just how well did the advisory effort do? One author who was very critical of the underlying premises of the program argued that in many ways its underlying premise was flawed:

Fulfillment [of US counterinsurgency advice to other countries] that it has regarded as essential to defeat insurgencies in foreign lands is not within the United States' power to accomplish. It is one thing to have the key; it is an entirely different matter to force another to use it to unlock a door through which he does not wish to enter.<sup>40</sup>

More broadly, even well planned and well executed advisory programs rely upon the host countries' capabilities and mission execution to succeed. If their militaries and governments are not willing or able to adopt the measures necessary, all the US support conceivable will not make a difference.

There certainly is some validity to this argument. Almost by definition, the responsibility for successfully conducting a counterinsurgency campaign will remain with the host country's forces. US advisors and security assistance personnel can do only that: advise and assist. Clearly, their roles will continue to be limited.



The counterarguments—particularly in the case of El Salvador—are more persuasive, however. It would seem very difficult to assert that the ESAF was not significantly improved by the end of the war. By almost all accounts, it was better trained, better equipped, more capable in the field, and at least less prone to widespread egregious human rights abuses. It is conceivable that all these improvements would have taken place even without the participation of US advisors, but the counter-example of the course of the war in Guatemala (in which there was no comparable US effort) suggests that the US advisory effort did in fact make a significant difference.

Certainly, none of this is to suggest that the performance of either the ESAF or the US advisory effort reached perfection. The ESAF continued to have operational and human rights problems throughout the war. The US security assistance program continued to have some weaknesses including the somewhat arbitrary limit on advisors; continued uncertainty as to funding levels; shortfalls in the overall training system; and issues involving the selection and training of advisors. Overall, however, the advisory effort seemed to have some very positive results. The limited number of US troops involved did have a strategic impact. As such, both the strengths and weaknesses of the security assistance effort offer valuable lessons for the future.

## Endnotes

1 Counting the 'true' number of US personnel actually in El Salvador at any given time became somewhat of a political parlor game. With support personnel and temporary duty assignments, it is probable that the normal average was about 100 to 120 US military personnel, with occasional peaks of about 150. Whenever war opponents tried to use the higher figures, the Administration normally was able to demonstrate that the number of actual advisors was still a maximum of 55. For a good account of how this numbers game was used politically, see UPI, "US Embassy in El Salvador Says Forces are within Limit", published in the *New York Times*, 13 February 1985.

2 The issue of practical support for the FMLN from other countries was very contentious during the war, with critics of the US administrations claiming that the FMLN was solely an internal movement, and no weapons or other military equipment were reaching it from outside. Although US intelligence reports (some of which made it into public domain) continually pointed to significant support from Cuba and Nicaragua in particular, opponents of the war discounted these findings. It was not until 1989, with the crash of an aircraft inside El Salvador ferrying weapons from Nicaragua that clear public proof was provided. It is far from certain, however, that this changed all opponents' minds.

3 Erling Steine Larsen, *Civil-Military Relations: Continuity or Change? A Comparative Analysis of El Salvador, Guatemala and Honduras*, Unpublished Thesis, University of Bergen, February 2004, p. 76.

4 Max G. Manwaring and Court Prisk, *El Salvador at War: An Oral History*. (Washington DC: National Defense University Press, 1988), pp. 233.

5 Quoted in Manwaring and Prisk (Oral History), p. 145. Likewise, General Carlos Vides Casanova, Salvadoran Minister of Defense, recalled a meeting he had with officials in Washington in 1983 in which they expressed concerns that El Salvador would fall within 15 days; *ibid*, p. 285.

6 For a good discussion of this issue, see John D. Waghelstein (MILGROUP Commander from 1982 to 1983) in Manwaring and Prisk (Oral History), pp. 278-281.

7 Max Manwaring and Court Prisk, *A Strategic View of Insurgencies: Insights from El Salvador* (Washington DC: National Defense University, McNair Paper Number 8, May 1990), p. 18. Also see A. J. Bacevich et al, *American Military Policy in Small Wars: The Case of El Salvador* (Washington: Pergamon Brasseys, 1988).

8 The full report is available at [www.gwu.edu/~nsarchiv/nsa/publications/elsalvador2](http://www.gwu.edu/~nsarchiv/nsa/publications/elsalvador2)

9 Jose Napoleon Duarte, *Duarte: My Story* (New York: GP Putnam's Sons, 1986), pp. 170-171.

10 Manwaring and Prisk (Oral History), pp. 114-115.

11 National Bipartisan Commission on Central America, 1984, p. 102.

12 For an early Congressional expression of this fear, see Associated Press, "U.S. Escalating Military Involvement in El Salvador", 3 March 1981.

13 Rod Norland, "U.S. Running Salvador War", *Philadelphia Inquirer*, 29 May 1983.

14 COL Joseph Stringham III, MILGROUP Commander from 1983 to 1984. Quoted in Manwaring and Prisk (Oral History), pp. 148-149.

15 For some examples of the problems as viewed by some of the key players involved, see Manwaring and Prisk (Oral History) pp. 100-105.

16 For example, see Ambassador Pickering in Manwaring and Prisk (Oral History), p. 244.

17 Manwaring and Prisk (Oral History), p. 398

18 For example, see the remarks of General Nutting of SOUTHCOM in Manwaring and Prisk (Oral History), pp. 401-402. Ambassador Pickering also expresses similar views, *ibid*, pp. 485-486. For an overall assessment of US planning and execution, see Max Manwaring and Court Prisk, *A Strategic View of Insurgencies: Insights from El Salvador* (Washington DC: National Defense University, McNair Paper Number 8, May 1990), p. 9.

19 Quoted in Max G. Manwaring and Court Prisk, *El Salvador at War: An Oral History*. (Washington DC: National Defense University Press, 1988), p. 235.

20 COL John D. Waghelstein, quoted in *ibid*.

21 *Ibid*, p. 236.

22 Manwaring and Prisk (Oral History), pp. 302-304.

23 For a good description of the underlying issues with the Salvadoran handling of their NCOs, see Major Paul P. Cale, "The United States Advisory Group in El Salvador", Command and Staff College, 1996, p. 21.

24 James S. Corum, "The Air War in El Salvador", *Air Power Journal*, Summer 1998.

25 *Ibid*.

26 Manwaring and Prisk (Oral History), p. 408.

27 Colonel Sigifredo Ochoa Perez, quoted in Manwaring and Prisk (Oral History), p. 331.

28 Marcos R. Mendez, "The Role of an MI Advisor in El Salvador", *Military Intelligence Professional Bulletin*, October-December 1993 (19/4), p. 29.

29 For details, see AP, "3 Advisors Relieved of Duties in Salvador", 6 February 1983.

30 Victor J. Castrillo, "Shortcomings, and Lessons Learned from U.S. MI Training/Advisory in El Salvador", *Military Intelligence Professional Bulletin*, October-December 1993 (19/4), p. 42. For a more positive 'official' view of the preparation of MI advisors, see Victor M. Rosello, "Reflections on El Salvador", *Military Intelligence Professional Bulletin*, October-December 1993 (19/4), pp. 26-27.

31 Manwaring and Prisk (Oral History), pp. 405-406.

32 Major Robert J. Coates, "The United States' Approach to El Salvador", Thesis for the Command and Staff College, 1991. For a similar argument, see Bacevitch, et al, pp. vi-vii.

33 See Castrillo, p. 42.

34 Manwaring and Prisk (Oral History), pp. 243-244.

35 Manwaring and Prisk (Oral History), p. 291.

36 Quoted in Manwaring and Prisk (Oral History), p. 213.

37 Benjamin C. Schwarz, *American Counterinsurgency Doctrine and El Salvador: The Frustrations of Reform and the Illusions of Nation Building* (Santa Monica, CA: RAND, 1991), p.40.

38 Cited in Cale, p. 25.

39 Schwarz,, p.38.

40 Schwarz, p. 77. A generally similar argument is made by Michael Childress, *The Effectiveness of U.S. Training Efforts in Internal Defense and Development: The Cases of El Salvador and Honduras* (Santa Monica, CA: RAND, 1995).



## Day 2, Panel 5 Question and Answers

(Transcript of Presentation)

Moderated by  
**Dr. Ricardo Herrera—Combat Studies Institute**

### **Dr. Ricardo Herrera**

I'll exercise the moderator's prerogative and just make a very few number of comments. The comments are based upon the papers that I read. In each case, they were well researched, well written, thoughtful papers. Each grounded, very much so, in archival and primary research. They share common threads in their exploration of the nature and exercise of American Empire, an American Empire in these cases, whose territories were all formerly dominions of the Spanish Crown at one time, Haiti, more recently, France. Now, when I say Empire, I'm using that as a conceptual term. Something that is being explored by historians like Neal Ferguson, most recently Fred Anderson, and also Andrew Caton. They make cases for armies and security forces as institutions. Armies and constabularies as examples of nation's political characters, their characteristics, but even, if we can stretch it, armies as schools of the nation, both for the host country as well as the patron state. They also make cases for the negotiations involved and the hybrid forces and hybrid outcomes that come through these contacts.

In Dr. Coleman's paper, we see the evolution of a long-term relationship. A long-term relationship whose bonds were forged in war, a relationship whose dividends were paid because of that war. He offers important insights into the negotiation of security assistance, as well as its evolution.

In Captain Mihara's, we see the beginnings, I think, of a valuable and intriguing paper. It's a very good comparative study. I'm inclined to believe his thesis, but in the process, he seeks to prove the thesis, not so much by positive evidence of constabularies that succeeded so much as by the absence of evidence proving the argument. This is within the paper. It points to a lack of focus in these constabularies, as well as a clarity of their mission. What do they exist for? For whom? What is their purpose? Looking at the Philippines, the case is highlighted when contrasted with Haiti, nominally an independent nation state.

For Dr. Cline, he argues that the success of the American advising mission in El Salvador was that of a good enough counterinsurgency. Something that we've seen brought up recently. Counterinsurgencies cannot be good enough. They need to go all the way. Larry Cline is arguing for something that contradicts that. There's an interesting contrast within his paper about the Officer Corps and its primary loyalty to one another, as opposed to the Colombian Officer Corps, which embraced

a proud tradition of civilian oversight. We see, in fact, with El Salvador, some linkages that have more in common with Captain Mihara's paper, with the Philippines.

We see in all of these papers, armies and security forces acting as schools by which nations learn; schools by which the United States makes its positions felt; schools by which each country learns from the other. With that, I'll leave it to the panelists.

#### **Audience Member**

I wrote this question before you finished, Dr. Cline, and you answered it on the very last slide. So I'll refer it to Dr. Coleman and Dr. Mihara. How would you assess the relative importance of the host nation's acceptance of the goal, the plan, the vision, and the US Army's acceptance of the goal, the plan, the mission? Which one of those, in your view, is most important to the ultimate success or failure of the case studies you've examined?

#### **Dr. Bradley Coleman**

What I've discovered and what I've detailed across time is that there's been a collaboration in establishing what those goals and objectives, the bilateral relationships, are. It is not ... part of the dynamic of US and Colombian relations, which I didn't discuss in detail here today, is my impression that Colombia resides on a zone of the area of great US influence, which is in the Caribbean, and sort of the more distant countries, Argentina. So there is this independence that characterizes the US and Colombian relationship across time. I find, in detail, the ways in which the two countries come together to establish those goals with relative independence, But I think one facet that sort of unifies all these papers also is the degree to which the host country defines, and also sets, the agenda for the countries.

#### **Audience Member**

Thank you. I'd like to thank every panel member for a very interesting discussion. This question is for Captain Mihara. I don't know if you ran across it, but last month there was an article in the *Weekly Standard* called "Cop Out. Why Afghanistan Does Not Have a Police Force." It ... I apologize, I thought I brought it along, but I don't have it to share with you. I hope you read it, or ... but briefly, to summarize it, there's a turf battle between the Army and the State Department, the State Department's International Narcotics and Law Enforcement (INL) Division, over who gets to train the police. There's a serious policy dispute. The Army thinks that it should be ... you should have SWAT teams and sort of a police force prepared for insurrections, prepared for, not quite military, but perhaps paramilitary operations. Apparently the current police force did very poorly in the riots of

recent vintage. Whereas the INL thinks no, no, no, you shouldn't have any of this military trapping. It's not good for a police force. We should have cops that walk the beat, sort of thing. I was wondering if you might comment on that. If you can see any way out of this dilemma which is going on in Afghanistan.

### **Captain Robert Mihara**

Of course, I have all the answers. I haven't read the article, but I would say that from the experience of the Philippines and Haiti, it's not so much important who trains them as the organization has a clear mandate and purpose, and that it is integrated into a larger security architecture. What you had in the Philippines and Haiti were organizations that just filled a vacuum because there was no overall security architecture, so what you had was a constabulary doing the Army's job, and no one doing the constabulary's job. So they were competing with each other. There's nothing wrong, I don't think, with the military training a constabulary. They are, after all, a paramilitary police force. As long as they have a clear mission, a clear mandate, and they integrate well with the other security organizations, I don't think there's any problem with that at all. In fact, I would question the State Department's ability to resource something as significant as training a national police force.

### **Audience Member**

John Hoffman. I'm with the Center of Military History, and in my former life was a Marine Corps historian with some expertise in Haiti, so this is kind of more of a comment than a question, but you might want to react to it, Captain Mihara. I think your thesis was well taken, and a fresh perspective on it, but I would add that there's probably a little bit more to the failure of the Gendarmerie. Kind of come from Dr. Cline's paper, and that is how people were selected and how they were prepared to go down there and work with the Gendarmerie. In fact, Marine junior officers and NCOs were the actual officers of the Gendarmerie, not advisors. There was really no selection criteria, there was no training given them, it was just assumed if you could be a good NCO in the Marine Corps, you could be a good second Lieutenant in the Gendarmerie. As they found out, literally, more than 1/3 of those people were relieved for cause because they didn't handle that well. It goes back to something else we've talked about, culture. This was a white Marine Corps trying to develop and lead a black Haitian force, and racial attitudes would get in the way and things like that. So, good paper, and just go a little more additional reasons why things didn't necessarily work out so well.

### **Captain Robert Mihara**

Yes, sir. I concur on all counts. You see the same problem with the Philippine constabulary, with the initial screening of officers. Haiti, obviously they gave up on training them, they actually just ended up ... instead of trying to bridge the language or cultural gap, they just had them mimic ... follow after me to train the Gendarmerie. So they only got them so far, obviously.

### **Audience Member**

Dr. Stewart. Dr. Cline, you raised an interesting point on ... I think it was your last slide, or next to the last slide, and that is human rights. You raise the whole issue of leverage. This fits into all the advisor's experiences, I think, that we run into in Vietnam and in El Salvador, and probably in other places. What leverage really does a US advisor have over those people that he is advising? I mean, does he threaten to hold back support from them? Sort of cutting off his own nose to spite his face. He's undercutting his position. At the same time, especially with human rights, a lot of times, the El Salvadoran senior officers, especially the Majors and Lieutenant Colonels, weren't interested in listening to him about this human rights business. They had enough of their own authority and personnel to do what they wished. And they could sort of blow off the advisor. Expand a little bit, if you would on the degree to which leverage worked or didn't work, and whether it ultimately undercut their position on a number of occasions.

### **Dr. Lawrence Cline**

It was a nightmare, is the short answer. The standard line, because essentially just preaching human rights everybody quickly gave up on as being somewhat ... I won't say a lost cause, but if they didn't get it from a moral standpoint, they weren't going to get it. Essentially, at the upper level of MILGROUP, and for that matter, the upper level of the US government, the argument essentially was if you don't clean up human rights, Congress is not going to approve funds. We might love you like brothers, and want to sing with you, and as was already mentioned, we'll sit around and sing Kum-Bah-Yah, but you won't have the money because Congress won't support it. At the lower levels, there were some very practical things like don't shoot prisoners. Prisoners can give you intelligence. And after awhile ... I mean they would see this actually work, and it took awhile, but they saw this work. Don't brutalize the civilians, because the civilians can give you intelligence. At the lower levels, the brigade, the battalion levels, essentially those were the sorts of arguments that were used. Trying to keep it very practical. The worse your human rights record, the less chances there are of you winning the war. There were certainly ... it obviously would create some friction. In some cases, and I can't prove this, but I suspect some advisors probably lost all rapport with their units,



not particularly through the advisor's fault, but the fact that their units would not stop committing human rights abuses, and they would feel obligated to continue to try to get them to stop. So it certainly was a point of significant friction. As I say, clearly it never ... the US never succeeded completely in it. I think it is fair to say, as I say, that the east half of the Salvadoran military did clean itself up quite a bit. The other problem, though, and I won't go into this in detail because of time, but the other problem was the Salvadorans could see what was going on in Guatemala. And the Guatemalan government was winning it's war, and not worrying in the least about human rights. So they were sort of using that as a counterfactual, if you will. Why should we worry about human rights? The Guatemalan government seems to be doing quite well. And then, of course, that was ... particularly when the US funding issue would have to be brought up with them. So it always was a significant difficulty, but I think most of the advisors, ultimately, went with the practical impact rather than the larger moral impact of human rights.

#### **Audience Member**

Lieutenant Colonel Kevin Farrell. My question, again, is for Dr. Cline. Two simple questions. First, you mentioned the impact on careers for those that went to El Salvador, but I'd be surprised, was that true also for Special Forces (SF) personnel? Because I mean, wasn't that a mission they would want? My second question, perhaps somewhat related, if they were prohibited from going on combat patrols, how was it that years later they were retroactively awarded, in many cases, combat decorations to include the Combat Infantryman's Badge (CIB), and I believe other decorations for heroism?

#### **Dr. Lawrence Cline**

The second question is very easy. There is a Congressman, I believe he's from Ohio, who served as an advisor in El Salvador, that seemed to be his one political mission in Congress, was to get combat awards authorized. Because up until that point, nobody in El Salvador was a combat veteran. Overnight, ten years after the war ended, golly, combat veteran. Very honestly, I don't know, for instance particularly with the CIBs, I don't know what their criteria was. I think it was just anybody who was assigned down to brigade or battalion level as an advisor, probably was given the CIB. But being a 35 type instead of an 18 type, I don't know on that. I'm sorry, the first question?

#### **Audience Member**

How was it negative? Special Forces personnel, I would think that's a key assignment. Especially it's in their area and part of their mission.

**Dr. Lawrence Cline**

As I say, everybody in 7th Special Forces Group was fighting to get down there. Having said that, though, at least one officer I was with in 7th Special Forces Group, the 18 branch suggested to him that he not go down there. He'd not pulled the tour as an advisor. He was a Major. Because he was due up for Battalion S-3, and they considered Battalion S-3 to be more important than to be an advisor in El Salvador. So even within SF branch, there was a certain amount of that.

**Audience Member**

Major Story. I'd like to ask a question focused on El Salvador again, and the challenge appreciating what Special Forces can do without exaggerating what they can do. It comes down to this, two recent ... in the last couple of years, I've had an SF Major refer to the victory that SF won in El Salvador as proof that SF can do it all. At the same time, and this follow up is hearsay, I understood from a conference held at Fort Carson sometime in the last six months or so, that an SF Colonel suggested really all you needed in Iraq was an SF brigade. So the question goes to the heart of ... you know, in the SF community, how do they understand what they are capable of, versus perhaps what exceeds their capabilities?

**Dr. Lawrence Cline**

The US won a strategic victory in El Salvador because there's a friendly government, very supportive of the US in power. Therefore, a strategic victory. But as far as actually defeating the Farabundo Marti National Liberation Front (FMLN), that never happened. But both sides sort of ground to a halt and agreed there was no point in further fighting. We probably don't have time ... I can get with you separately on what I would consider SF able to do or not to do. SF, though, is ... again, we get into the issue of white and black SF, which has turned into a nightmare in Afghanistan, in particular. But certainly for advising and assisting, absolutely a force multiplier, but there are limitations. We can discuss this sort of off line if you'd like.

**Dr. Ricardo Herrera**

Alright. If there are no further questions, we will commence our break.

## **Expanding Global Military Capacity for Humanitarian Intervention**

(Transcript of Presentation)

### **Dr. Michael O'Hanlon—Brookings Institution**

Thank you for the very kind introduction. It's a real pleasure to be here. I had the distinct honor of having a conversation with General Petraeus and Andy Krepinevich, who I ... at the end of the conversation just now, said that it was a great tribute to be able to spend an hour with two of the Army's top ten counterinsurgency theorists, and I think the other eight are probably in this room as well. So I'm going to try to keep my remarks short enough that I learn a lot, but what I want to do is actually talk about a topic that I was asked to address here that is partly counterinsurgency, but also partly what some of you were doing in the '90s, and it's peacekeeping. Actually, I'd love to hear a conversation about the relative difficulty of Bosnia versus Iraq, and how many of the world's problem spots are more like Bosnia than Iraq. I'm hoping a lot, relatively speaking. I'm trying to essentially address a conflict that, even though it's not a type of conflict ... you know, even though it's not the one we're presently engaged in Iraq, has been historically, at least through the '90s, more the international norm. And I think a lower bar of capability is often adequate to address it. It's, nonetheless, a kind of capacity the world doesn't have much of.

I'm glad you mentioned the Congo Peace Corps experience, which, for me, is maybe a little more genteel version of my overseas service compared to what some of you have had to do in this room, if not virtually all of you. I didn't have too many people shooting at me in Congo. I had one guy try to rob me with a machete, but that was enough excitement for two years. What I saw in Congo influenced me in a way that I know all of us are influenced at certain moments in our career by defining experiences. So I'll just get this sort of autobiographical note on the table, which gives you a little bit of the context for the substance of my talk about expanding global capacity for humanitarian missions.

The context was that in Congo, most of our sins were sins of omission. That's probably true more often than not for a global super power that has to think about so many different continents and has limited resources and limited attention span. But to the extent that we could do more, especially today, in Congo, the main issue, as much as the doctrinal development that you've done here at Leavenworth and elsewhere is important, the main problem is the world just doesn't have enough half-way decent infantry to handle these sorts of conflicts. So I'll come back to

Iraq, and I hope you will too in the discussion period, but I'm trying to establish a little bit of a lower bar for capability.

I would just like to see, in the future, missions like the one in Congo that the UN is presently trying to do with 16,000 people in an area the size of the US east of the Mississippi. Missions like the one in Darfur that we've been talking about maybe doing right for three years, and still haven't, as a global community. Even as a quarter million people have died. Missions like the possible intervention in a Rwanda genocide scenario in '94 that the world didn't do and didn't really have the capacity for. And Bill Clinton felt politically incapacitated from doing that one at that moment, and so nobody else did because nobody else could. That's not a great place for the world community to be. Missions like the one in West Africa that could have been done much more assertively, much earlier. Where ultimately we brought in the Nigerians, after helping them train up for a period of time, some of you may have been involved, for all I know, to address some conflict in West Africa. Sure, it would have been nice if the Nigerians had been even better, even more selective and careful in their use of force. Bottom line is, West Africa just needed a little bit of somebody to come in with authority and some level of discipline and cohesion and stamp down those crazy wars in Sierra Leone and Liberia that were leading to small little militias chopping people's arms off. A lot of times, what the world doesn't do right is just have a basic competence of infantry forces that it can deploy. That's my motivation in talking about the topic that's on the forum agenda today.

And again, we can bring it back to Iraq, but I think the Iraq challenges are much different. Even the Afghanistan ones, from what I can tell, are somewhat different because it's a more combat oriented type of humanitarian intervention, if you want to term it that. It's the highest difficulty military intervention that I can envision, where you're doing nation building, counterinsurgency, peacekeeping, all together, all at once. The pentathlete leader that we were just talking about. And Iraq is state-of-the-art. Iraq is the sort of thing that, obviously this is testing the ability of the military of the United States, at this point, even to prevail with some modest level of victory. Whereas a lot of these other missions, frankly, I think are fairly doable in a fairly straight forward way, if the world has capacity.

Now I don't want to over simplify. Obviously, in most of these wars, you can also get into trouble if you go in naively. And we did that, perhaps, in the early Clinton years, in Somalia. And we did that, perhaps, in the early Clinton years, in Haiti until we figured out the right way to go back a little stronger the second time. Even after we went back the second time, we didn't produce a brilliant success, obviously. But at least there was some minimal level of security established in a

number of these countries. And it's often doable. It's often the sort of thing where, if you go in with modest expectations, that all you want to really do is prevent all out war and help a country get back on it's feet, I think you've got a 60, 70, 80% chance of success, statistically speaking, if you go in with a decent level of capacity. There are a lot of places where peace agreements have stuck. Mozambique. Now granted, often after a lot of warfare. It would have been nice to stop that war sooner. Cambodia, part of Central America. There are a lot of missions where we didn't really succeed as early or as well as we would have liked, but compared to the alternative of continued all out civil war, things look pretty good. And wouldn't it be nice to be able to do this better, right now, in places like Congo and Sudan?

So that's sort of the normative motivation for my talk. It's not just a humanitarian issue, though, because obviously there are strategic implications to even these smaller, more remote conflicts when you're talking about a world where al-Qaeda gets resources from some of the more failed state regions of the world where it can profit from diamond or timber trade, where it can establish sanctuaries for training. I think a lot of failed states are potential battle grounds for the opposition in the broader global war on terror. So there's always a strategic aspect to these as well. But I think there's a humanitarian aspect, in addition, that maybe even is one we should not be afraid to admit.

This may sound like a little bit of a funny talk for an Army at war, so overstressed in Iraq, so directly dealing with immediate challenges to our nation's core security interests in the Central Command (CENTCOM) theater in Iraq and Afghanistan, but a.) it's the topic asked to address, so you're going to have to listen to me on it, regardless. And b.) I think it is relevant in this broader sense, that we don't have the luxury of tolerating failed states, even in places where the stakes may be somewhat lower than Iraq or Afghanistan. We've got to think, are there practical ways to go out and make a difference?

Now don't worry, I'm not leaning towards a proposal that would have all of you take your one year you get at Leavenworth, and have to go out and deploy to Congo as your break from Iraq before you go back to Iraq yet again next year. This is not about the US military doing more in most of these, for the most part. There may be a little bit of that, but for the most part, I'm proposing a global agenda in which our role would be largely political support, catalyzing other countries to do this, strongly supporting countries like Germany and Japan to get more capacity to do this sort of thing, even though there are complicated political issues associated with such things. Maybe even encouraging countries like China to do more of this. And also providing resources for countries in Africa, where I bet some of you in this room have been involved in various training programs over the last ten years.

To do this sort of thing more systematically and more thoroughly. I know there are challenges, I know there are problems. It's not just a question of money, it's hard to make it work, and even if you have trained forces, you still have to use them in an intelligent, well designed mission. Yes, there are a lot of caveats.

But I still am going to finish this introductory part of my talk with the basic challenge, I think, to us all. We can't, in good conscience, watch a Darfur mission, or lack of mission, watch a Congo mission, or lack thereof, and say, "We wash our hands of this because we're too busy, we're preoccupied with Iraq and Afghanistan, and these just don't rise to the level of strategic significance for us to be able to afford the attention or the resources to handle them." It's not good enough for the world to say, "These places are distant, they are second order problems, and therefore we don't really care." If you have better reasons not to go do a mission, okay, let's debate the better reasons. But right now, lack of troop capacity is often the real reason for the international community at large. Not so much for us, but for the international community on the whole. This is often the main constraint in why we do these missions in such a haphazard way and you only get about one out of every three or four right in a timely manner, where I think we could actually aspire to get at least one out of every two right in the sense of making a difference in a timely way and helping these countries toward stability. So that's sort of the motivation for where I'm coming from. And this based, by the way, largely on a book that I did, a short book, three years ago at Brooking, so the numbers I'm going to quote from are largely from that book. I'll give you some rough orders of magnitude of the kinds of effort I think are going to be needed, but I wanted to motivate the basic notion here first. So that's what I wanted to introduce.

Now let me get at it in another way. That's the broad, normative, and strategic motivation for trying to improve global capacity for humanitarian military intervention. But some people would say, "Look, the world just doesn't want to do this, and the world just can't do this." Well, I grant you the world doesn't want to do it, but I would not concede the world can't do it. And what I mean is the following. Let's look at our NATO partners. And we all love to beat up on NATO, and I'm going to do a little bit of it now in terms of ... they're great allies in some ways, but they have limited capacity in others. I'm afraid that's true, but what I'm going to suggest, and I hope there are a couple of potential NATO friends in the room, or at least people who have spent a lot of time there from the US military, what I'm going to suggest is it's not that hard for NATO to do better. And some of NATO's instincts are in the right direction, and the fact that NATO is so strong in Afghanistan is pretty remarkable, given that it's pretty far from the NATO theater. And yet we're acting there as an alliance that's basically a self-protection, self-defense, Article V alliance, and yet we're several thousand miles away. So there's a lot of

good stuff happening. But what I want to remind you of is that NATO, collectively, spends close to \$200 billion a year on military operations and force structure and weapons, not counting the US, and has about three million people under arms. For all of this spending and all of this manpower, NATO outside the US, typically is able to sustain about 50,000 to 75,000 people in the field at once. So that is an abysmally low ratio.

We all know that Secretary Rumsfeld ... and I'm sorry, actually General Schumacher used to have a metaphor that he used a lot, I'm not sure if he still uses it very frequently, when talking about this same problem, which is that our NATO allies have a lot of military manpower, sort of the equivalent of the beer in the keg, but the tap is way too high on the barrel and they can only get a little bit out. It's not a bad metaphor, and it's one that I want to remind you of. If you haven't heard him say it, you can imagine he does it in his usual colorful way. It's pretty compelling. And, again, the good news is that NATO is moving in the right direction, in some ways. The NATO Reaction Force and so forth. But the bad news is that compared to three million people under arms, \$200 billion in annual defense expenditures, what NATO actually produces out of this is not nearly good enough. Part of the problem, I think, is that NATO countries don't realize they could actually make their militaries more deployable at the same cost. So I'm not going to give you a long lecture or argument on how our NATO friends can do better, since that's not really a very useful conversation to have in the heart of Kansas among Americans. But nonetheless, I would still submit, as part of our broad thinking about this problem, we should be very supportive of a German think tank's proposal that the right goal for NATO is to have up to 200,000 deployable troops, and not to be content with the 50,000 to 75,000 range that has been the norm in the post-Cold War era. I'm not talking about Iraq, necessarily. I'm talking about capacity at large, for whatever missions the Alliance ultimately decides to put these people towards.

So that's one big piece of the question. I sometimes like to tease my NATO friends, and again, I'm sorry to be doing this again among Americans. It's a little bit unfair. But I'll still use this line because I think it's a motivating line. If you imagined military operations being a game of paint ball, and as you often do at the combat training centers, essentially replace your real weapons with paint ball or a computer triggered or laser triggered equivalents, and we agreed to fight the Europeans, all of NATO together on a third continent, I submit the US Marine Corps would have a decent chance of winning the fight against all of NATO combined. What I mean by that is, of course, if the fight is on the third continent, we all have to use our logistics and our transport to get there and sustain our forces. You can't ... this has to be done fairly quickly. So if you imagine this exercise, you give people three months and you say, "Okay, the challenge is going to be to win

a notional paint ball war in Australia. And it's going to be the US against ... it's going to be the Marine Corps against all of NATO." NATO has about the capacity of the Marine Corps in that fight, if you add up the numbers. Another way to put it, maybe less flippantly, but more quantitatively, is coming from my book's research, we can deploy within reasonably short order, maybe 400,000 to 500,000 troops. If we absolutely have to at one time. We can do it within a few months. It's tough. Obviously we usually prefer a little longer build up and we usually prefer not to go to quite that number, but we could easily deploy, if we need to, 400,000 people within a few months, and sustain them once they get to wherever they are going. Even if it's pretty barren territory. The European NATO allies plus Canada together can do maybe 75,000. So that's the basic comparison.

But of course, if that's the situation with NATO, it's much worse with everybody else. The Japanese, and by the way, I think the Japanese need to moderate some of their foreign policy, some of their Yasakuni Shrine visits, etcetera, but the basic idea of having Japan more engaged globally in military operations is very good. We need them. We should encourage them. I think this is the kind of agenda that requires a greater Japanese contribution and requires us to start to get beyond World War II to the extent that we can help the Japanese figure out a little bit better message on how to do that within their own region. But even if they still meet objections from the Chinese and the Koreans and others about getting more deployable military capacity, they should do it anyway because what I'm talking about is not huge numbers. It would be nice if Japan could have 50,000 or even just 30,000 deployable forces they could sustain in the field.

I'm not suggesting Japan would deploy those to Iraq next year. We all know the limits on their Iraq mission in the past, primarily a reconstruction effort, not so much a military operation, even though it was done with self-defense force troops. But the Japanese have the capacity, I think, to contribute 25,000 or 30,000 troops to the global humanitarian intervention portfolio. We should be encouraging that. Thinking about a day when they can play that kind of a role, and moving towards it as soon as possible. Again, they can do it within existing defense budget constraints, I believe, if what they do is essentially acknowledge they don't need quite as large of a ground self-defense force any more because their territory is not really at risk. What they should be doing instead is going toward a smaller, but more deployable ground force, with maybe one division equivalent, or several brigades equivalent of easily deployable and sustainable combat capability with roll-on, roll-off ships, with mobile logistics, to be able to sustain that force in theater wherever they go.



Likewise, I mentioned earlier, I'll just mention in passing, the Chinese, the Koreans. We should encourage others to do the same sort of thing and get beyond some of the political hang ups that we don't want to see the Chinese get more involved globally. I think the Chinese will get more involved globally. They already are getting more involved globally. What we should want to do is help steer them in a constructive direction, so instead of seeing the Chinese go off and make friends with Mugabe and with the Sudanese and with the Iranians and with Chavez, which is what they tend to do if left to their own devices. If we create a competitive dynamic in interacting with them in the developing world, what we should try to do is also encourage them to play a greater role in international military humanitarian operations. The Chinese probably won't want to do a lot of this, they probably say they have a limited defense budget, only so much capacity, so on and so forth, but they also recognize that there is some validity to this argument. They do a little bit of it already. And we should encourage them on. This should be, then, one of the benchmarks we look to, to see if they are trying to use their foreign policy and their greater military might in a constructive way, for the good of international stability, or are they just focused on building up capacity to attack Taiwan? It actually gives us a tool, a metric, by which we can assess some of the purposes towards which they're putting their increased military power. So I would argue it has a sort of hard-headed, cold, strategic benefit to us, even if it's primarily a humanitarian kind of motivation at the heart of it.

So anyway, I can go around the world and talk about different major industrial regions, but I think you get the drift of what I'm suggesting that we do. I don't pretend this should be a major element of American diplomacy, that all of a sudden George Bush gets up tomorrow and says, "I want the rest of the world to get ready to intervene in Congo and build forces so they can do it within two years." I mean, I'm trying to live in the real world here too, even as I give this talk that is somewhat notional and somewhat speculative about where the future could bring us. But I think that we have to have a clear sense of what we would like to see other countries do militarily so we can have useful discussions with them at the alliance planning level, at the mil-to-mil exchange level. And to my mind, this would be a very useful way to try to steer people. Most ground forces in the world, as you know, can't do what you do, which is sustain yourself in an unpleasant, inhospitable place very long. You know, most militaries, they'd probably do about as well as us Brookings guys, most of the other militaries, at being able to go off to the middle of nowhere and actually figure out how to repair their equipment and get themselves water, and get themselves medical care. They usually ask your help if they're going to an inhospitable place because they maybe can provide a few guys with rifles, but not people to sustain them.

We all know the old idiom that amateurs, like Brookings scholars, talk strategy, but professionals talk logistics. Well, you guys talk logistics, and most of our allies still don't. That's a fundamental constraint on the world's ability to do these sorts of operations and do them well.

So that's one more piece of the problem. But in terms of real US policy, what do I suggest that we do here? Well, I think that the Bush Administration has picked up a Clinton initiative and done a very good thing with it. Unfortunately, the Congress has not been very forthcoming in providing the money. Mr. Bush hasn't always gone back to the Congress and the American people to reiterate the importance of this mission. But it's the Global Peace Operations Initiative. And what we've been doing in Africa since the late '90s, first with the Africa Crisis Response Initiative, then with the Africa Contingency Operations and Training Assistance Initiative (ACOTA) with the training of the Nigerians and with certain other missions through traditional International Military Education and Training (IMET) programs and the like, is trying to build up more capacity for these sorts of operations.

I think that the original Clinton goal of \$10 million a year was just a seed kind of funding level, and it was not very much. It was just to get the idea going. President Bush has wanted to push that number up closer to \$100 million a year. He hasn't quite gotten as much as he's asked for, but at least he's aspiring for the right kind of number. I think this should actually be a several hundred million dollar a year US initiative, with some of that money to pay our poor, often criticized, private contractors to go off and do training. Maybe they have a hard time, in some cases, in Iraq, but our private contractors will do a just fine job in most of these situations in Ghana and Mali and elsewhere. And this may be a way for them to help remind the American people of just how much they bring to the table at a time when their reputation has been a bit sullied, in some cases, by the Iraq experience. But in addition to that, I think buying equipment for some of these African militaries should be ... and I'm thinking largely about Africa, since that's where many of these conflicts occur, should be a reasonable way for Americans to spend money on a useful foreign aid program. You know, the original Clinton program, I think you could buy eyeglasses. You could buy other non-lethal gear with the money, but that was about the extent of it. We've been very unenthusiastic about doing this program rigorously. But I think it's time to say, "This is the kind of program we need." The African Union is trying to handle Darfur on its own, it can't, God bless it for trying, let's help it get better for the next one. And maybe let's help it even get better on a crash basis in time to do this one correctly, if none of the rest of us are willing to do so.

So, I'm beginning to sketch out the vision here of where I think the world needs to go. To summarize the numbers, I mentioned earlier we have maybe 400,000 rapidly deployable and sustainable ground forces in our military. What I mean by this is using the NATO metric of deployable within a couple of months, sustainable for at least a year. We could probably do even more than that on a crash basis, if we needed to, for a short period of time. Our European allies maybe have 75,000 or 80,000 combined between them. Countries like Australia have 5,000 to 10,000 they could deploy and sustain. If you add up the whole world, the whole world has maybe a total of 600,000 deployable, sustainable troops, of which we provide 2/3 of the total. That sounds like a lot, 600,000 troops, but of course, as you well know, at least in the old days we used to believe in 3:1 and 4:1 rotation rules before we started sending you all to Iraq every other year. But still, as a matter of sustainable military policy, we should be aspiring to have at least three times the number of people we might need globally in a mission, because we want to sustain this over an indefinite period, if necessary. We also don't want to have the composition be primarily American. Because the US military is otherwise preoccupied at the moment, and because these missions are not ones the US should be particularly expected to do a disproportionate share of the fighting or peacekeeping for. We should do our part when we can, but generally speaking, this has to be a global sort of responsibility.

So if I work through the numbers, and I look at all the missions that we've done in the world since the end of the Cold War, the world has typically deployed, in very broad numbers, 100,000 troops at a time for peacekeeping, roughly speaking. A lot of it was in the Balkans in the '90s. Sometimes we had bigger missions in a place like Sierra Leone or in a place like Ivory Coast, Haiti. Some of the missions have waxed and waned obviously, but if you take all the UN and non-UN peacekeeping missions and add them together, we've typically been deploying about 100,000 troops at a time. And what I did with former Congressman Steve Solars in some writing we did in the '90s, and then more recently in this book that I mentioned, is I tried to say, "Well, how many missions should we have done?" If you try to imagine stopping Rwanda genocides and Liberia genocides earlier and more effectively and more robustly. Or today, if you imagine going into Darfur with the 20,000 to 30,000 troops that are probably needed instead of the 7,000 who are there, or if Congo you do with 50,000 instead of 16,000. What kind of numbers do you get? And I would propose to you that the world should be able to sustain 200,000 troops at a time indefinitely in these sorts of missions. With Iraq being a big asterisk. I'm not counting Iraq in this. Iraq is the exception, not the rule. I'm talking about a different set of missions. I hope we come back to Iraq, as I mentioned, in the discussion, but that's not what I'm thinking about right now. So I

think the world needs to roughly double its capacity to sustain and deploy infantry forces for humanitarian military purposes.

I can go through some of the logic of that calculation if you want, in more detail, but I've given you a gist already of the sorts of missions that I think we should have done better or earlier or more robustly. That's the basic way in which these numbers get generated in my calculation. They also stay pretty steady from year to year, decade to decade. Since the Cold War ended, the world has had about 100,000 troops in the field, collectively, again, not counting Iraq, at any given time. Some of it UN run, some of it NATO. And that has been a fairly steady number. Also, it's been obvious throughout this whole period there were other missions that probably could have been done better, should have been done that weren't done, etcetera. And if you go through the numbers on these, I submit to you, obviously a somewhat subjective calculation on my part, but that you would add up to roughly 200,000 troops as what should have been the deployable number that we would have had in the field at any time.

To get up to that number, the world needs, therefore, another 300,000 to 400,000 troops that are deployable because right now, the whole non-US part of the world combined has 200,000. If we apply a 3:1 rotation rule, that means the world can't really sustain more than 60,000 or 70,000 at a time. We should have three times that capacity. So assuming the US will do some of its share in the future, especially once Iraq is over, I would submit to you that the rest of the international community needs to find a way to generate at least another quarter million to 300,000 troops who are deployable and sustainable. We should be designing our diplomatic strategy, our alliance dialogues, our NATO force planning discussions, and our Africa peacekeeping initiatives with that sort of framework in mind.

I could go on at greater length about some of the details of this, how many military police versus how many infantry forces. How do you deal with the threat that a military could pose to its own internal order? Or the possibility that you could train people that engage in civil war in their own country. All the sorts of problems that you often address when you're dealing with School of the Americas sort of issues. I mean, there are a lot of nitty gritty questions about how do you do this program right and how do you make sure you don't get into trouble. I'm happy to talk through any of that. Also, of course, there are ways in which you have to address the possibility, or the reality, that a lot of forces are going to turn over. You're going to lose a lot of people through attrition. You're going to lose a lot of people through HIV/AIDS. You're going to lose some people in some militaries through desertion. You're going to have to keep doing these programs indefinitely, in other words. You can't just do them one time and be done with them. It's like our mili-

tary. Basic training goes on all the time. Specialized training goes on all the time. It's a never ending process. So there are a lot of details to discuss about how you structure this sort of a program. How much do we integrate our new approach that I'm recommending today with the European approach? Because they're also often working in Africa on military cooperation. How much can you do through IMET? I'm happy to get into those details, but that's not what I really want to leave you with in the main talk.

I want to leave you with this vision that, again, we as the United States, cannot realistically expect you to do any more than you already are. You, as an Army. You, as American ground forces. What you're doing is incredible, despite the difficulty of the mission, despite the fact that it's not clear, to me at least, we're even going to prevail. I have incredible admiration for everybody in uniform and I know virtually all Americans share that sentiment. It would be unreasonable of us to ask you to do more. But strategically, we have to be thinking about our interests as a country. Even if we're not going to deploy our own forces in most of these missions right now, we can't afford to ignore them. I work in a think tank where foreign policy is supposed to be my job. Yet, I have to admit that I can go weeks at a time where Iraq or Lebanon or North Korea preoccupies me so much that I stop thinking about Darfur. And then three weeks later, I'm like oh, I remember that. Yeah, what's going on there now? Probably 10,000 more people dead since I last thought about it, but nothing's really happened. You know what? It's not realistic to think President Bush or Secretary Rice is going to be any different than the rest of us. Their brains are only so big and their time is only so much, and they're going to have these other problems crowd out their attention to Congo and Darfur, as well. Just to take the two latest, most prominent examples. So we need, as a matter of national policy, to figure out a framework for how to build up capacity so that it doesn't always have to be something we patch together with Scotch tape and overnight phone calls and last minute diplomacy when Darfur all of a sudden gets worse and we can't ignore it any longer. That's the wrong way to handle these things. And yet, it's always the way we do it as an international system. So I'm proposing that we get more systematic in creating military capacity.

Now, it's not going to solve the problems. Each one of these conflicts needs attention to the details of it by itself. Hearing, in the last hour, General Petraeus talk about the politics of Iraq. I mean, the challenge of getting any one of these missions right is enormous. Hopefully, not as challenging in every case as Iraq, but nonetheless, I'm not trying to pretend there's a technical military solution to the whole problem of global civil strife. But I am saying, again, to summarize and conclude on this point, we can no longer tolerate a situation where sometimes we don't address these conflicts because we just don't have the collective international

forces. That's not a good enough answer. That should never be a tolerable excuse for a world that has 20 million people under arms, that spends \$1 trillion a year, collectively, on its global armed forces, and that has so much technology and so much capacity, and so much interconnectedness. The idea that lack of infantry forces can be the major reason why we don't even have a conversation about doing Darfur right or doing Congo right is frankly not acceptable.

That may be a little bit different of a message, or a little different topic from what much of these two and a half days of your conference are about. I look forward to being brought back closer to the main topic in the discussion, but I wanted to satisfy the request of those who were kind enough to invite me here by giving a straight forward answer to the question that they put on the table, and that's what I would like to leave you with. It's a little bit of a shorter presentation, but it gives us time, again, to broaden the conversation in the Q&A and discussion. So I look forward to your reactions. Again, thank you very much for the honor of being here.

## Featured Speaker Question and Answers

(Transcript of Presentation)

### Dr. Michael O'Hanlon

#### Audience Member

Sir, Roberto Bran from the Department of State. I've read *Saving Lives with Force*, and I think it's actually a great book. I know that's where you're drawing a lot of what you were talking about when you were referencing it. I think, if you've read Michael Lewis' *Money Ball*, there's a great scene in there where Billy Bean is discussing with Michael Lewis, and he says, "I only have a \$30 million budget. The Yankee's have \$150 million. If I try to duplicate what the Yankee's are doing, I'm going to fail immediately. I'm going to buy Alex Rodriguez, and that's it. I have 24 back ups." And I think that's part of the problem with what countries are looking at if they try to build a US expeditionary capability to scale. If they just try to scale it down, they're going to buy their first C-130, or their first C-5, rather, and that's it. They're not going to have money to do anything else. So I think the solution there may be looking to some kind of compartmentalized alliance where the Canadians are providing the strat airlift. The Koreans are providing the infantry. The Salvadorans are providing the military police or the Special Forces. So on and so on. Europe would probably be the best model to start that with. But to do that, you're going to have individual countries which are going to be ... it's against their interest because now all they have is an armored battalion or whatever, and nothing else. I don't know ... how would you go about doing something like that?

#### Dr. Michael O'Hanlon

Thanks, great question. Well, I think you're right that there is a role for specialization, as long as you don't build in one point failure. Where you need the Japanese airlift fleet or you're done. That's the sort of problem ... there are only about three or four countries that are going to want to, and be able to, buy that high end stuff in capacity. So if you need the Ukrainian fleet or the Japanese fleet or the American fleet, and that's the extent of your options, then you're in trouble. So you don't ... I think you're right, as long as you don't over do it. As long as you allow for some breadth of capability across the international community.

The other point I would make, and I'm glad you set me up for making this point, I should have done it in my talk, is to say that people often over emphasize airlift, as I just did, or the high end stuff. Because to me, what impresses me about the US Army, for example, and it sort of, in a way, there are a lot of things that impress me, but as I got into this field and I started learning more about the Army, as much as anything what impressed me was roll-on, roll-off shipping that the Navy owns,

but you ask for. And trucks. People have used these sorts of metaphors before to say what's most impressive about the modern military, or about some of the great militaries in history? It's their ability to sustain operations at a distance over time. It's their logistics.

Ironically, even though it's one of the oldest lessons in the book, a lot of people still don't get this around the world. Certainly a lot of political leaders who make their defense budgets don't get it. Or maybe they do, and they just don't want to really have military capacity that's deployable, so their happy not to buy much sealift and much mobile logistics. But the bottom line is that you don't have to have a lot of money to buy two large roll-on, roll-off ships. I would submit to you that virtually any country in the Organization for Economic Cooperation and Development (OECD) should have a few roll-on, roll-off ships, of large size. Enough to carry, let's say, a battalion worth of capability, roughly speaking. Or at least a couple of companies. I mean, anywhere from a few hundred to a thousand troops' equivalent worth of equipment. And that's not that expensive. You can buy these kinds of ships for, depending on the size, \$100 million. And if you imagine this as part of your defense budget over a ... if you build this into your psychology and into your doctrine, and into your national strategy, and you've got a defense budget, let's say, of \$7 billion. You're the Netherlands or something. Buying two \$100 million ships over a seven year planning horizon, should not be, in theory, that hard. Now, in practice, of course, you've got to find it from an existing program. You've got to convince somebody else to pay the price or go to the taxpayer for more money in the defense budget. So I acknowledge it's easier to say this at the podium than it is to make it happen in a budget.

But, just to conclude, your point is right, but some of these costs are not as high as people think. Especially if you stay away from the airlift and if you stay away from the fighter support that only a small number of these missions really need. And you stay away from the satellites. Or at least you don't add any new satellite programs for this particular purpose. I think that you can actually do a lot by buying the right radios or the right trucks and the right roll-on, roll-off ships and the right kind of ammunition and the right kind of mobile hospitals and depots.

There was a very nice Congressional Budget Office (CBO) study done in the '90s that I quoted from and used quite a bit in my work that you mentioned. Basically it suggested that NATO could have the capacity to deploy four or five divisions if it spent \$50 billion in the right way over a ten year timeframe. Take \$50 billion, or \$5 billion a year, out of a collective procurement budget that was \$40 or 50 billion for the alliance as a whole, not counting the US. In other words, if you redirected 10% of the procurement budget, you could buy all the mobile logistics and all the lift you needed to do this sort of thing for several hundred thousand troops.



So yes, the money is an issue. And yes, therefore, we can allow some level of specialization, but it doesn't have to be that big of an issue because most of these operations just need halfway decent deployable infantry forces.

**Audience Member**

Steve Tenet, Command and General Staff College (CGSC). I'm curious to hear your thoughts on how, if you got this capacity, you would then lead it and what entity would provide command and control.

**Dr. Michael O'Hanlon**

Excellent question. The kind of thing, as I say, wouldn't want to pretend the forces themselves handle it. Well, it depends on the conflict. In a conflict like Liberia, let me take, or Sierra Leone. I don't want to be too flip, but I would suggest to you that, frankly, most halfway decent military planning organizations could handle the command and control of that. You basically have marauding bands of militias, high on drugs, made up of 14 year old kids using machetes to chop each other's arms off. To be blunt, that's essentially what the war was in West Africa. Led by Charles Taylor, an escaped convict from the United States, who was basically just a hooligan. And the Indian military could have done that. The Malaysian military could have done that. Obviously, NATO and the EU could have too. But I'm starting with the easy case, and maybe I'm over simplifying, and maybe you would challenge me back, and you're welcome to. But there are some cases where I think, in other words, as long as you make a clear answer to the question, as long as you say, "Give it to somebody that's got some kind of a proven track record in military operations." Most serious militaries or regional groupings could do it. As long as they've actually done something militarily before in their lives that's real. I don't want to suggest that a political alliance could automatically and immediately form an ad hoc military coalition, sharing command for the first time, working out those sorts of arrangements. I don't want to say that a bunch of Brookings guys could do it. But I do suggest to you that any military that has a track record of conducting operations could handle Liberia or Sierra Leone pretty well. Because the mission there is basically just preventing complete anarchy by providing some level of basic security in the street.

Then you can graduate up to somewhat more complicated missions, where you've got two sides fighting a real civil war. And you've got to figure out some way to either intersperse yourself between them, or defeat one of them. And that could be, for example, Jonas Savimbi in Angola. Now, I'm not trying to get into a discussion of the details of Angola. There are obviously a lot of Cold War issues and so on. I'm just saying, in a war such as that one, where you have a government and you have a major guerilla force, and neither one is too pretty of an organization. Neither one is too admirable, ethically, and you've got to figure out some strategy for

how to stop this, then there you actually need a little bit more capability in the planning and the strategy, because you've got to figure out, am I going to fight a civil war and try to defeat Savimbi? Or am I going to interpose myself along the line between the government and Savimbi and essentially have a loose partition until better political leadership emerges to solve this thing themselves? You need some kind of a clear strategy. I think in that situation, you probably ... you might still be able to delegate the military piece to, let's say, the Indians or the Malaysians. Certainly NATO could do it. But you need to have an internationally accepted decision on what your strategy is to stop the war. That's where the harder decision is. Not so much in the military operations, per se, but in the political framework.

In a place like Somalia in '93, where obviously we didn't handle it very well ourselves, I would submit to you that frankly, any one NATO country of moderate to large size that had been committed to the mission, and making the decisions in a way that involved its full national strategic leadership probably could have done an adequate job. The problem there was really a lack of will more than imperfections in the military command arrangement. I think the US certainly had the capacity, working with its partners in Somalia to run that mission well. It's just that we changed our minds halfway through what the mission was. And we weren't very committed to it.

So, I guess to summarize, I have two answers to your question, and this may or may not answer everything you were trying to get at with the very important query that you put on the table. One, militarily these missions do require clarity of command, and they require a decisiveness and discipline in the troops. But I think a lot of organizations in the world have the capacity to do most of these missions reasonably well. But two, they better know what they're getting into and be ready for it. In some cases, it's going to require combat. Because in some cases, you're not just monitoring a cease fire line, you're going off and you're defeating Jonas Savimbi. Or you're defeating the Rwandan genocide. And in those kinds of missions, obviously those are the ones that are more likely to involve us or more likely to have the world ask us to help. But even if we don't get involved, it has to be a country or an organization leading it that has the stomach for combat. Otherwise, you probably better save this global pool of new capacity for the missions that are a little bit easier. Where the only threats to the cease fire are smaller, more localized piece meal groups like in Congo today. Or where the international community has really developed a concept of operations over years of watching the conflict that would then guide the international force, as I would propose might be the case in Darfur. I think we've had enough time thinking about possible rules of engagement, we just need to decide what they are, and empower an organization to go off and do it.

So in other words, the hard part of this is sometimes the military piece, but more often it's the political piece, making sure that the world really knows what it's prepared to do with these forces before it deploys them. And that is a caveat, a big caveat to my overall recommendation. It's one of the reasons why I said in my talk, even if you had all these forces, you're not always going to succeed in stopping conflict because some of them are going to be just too messy and too hard to be able to resolve, even if you have more force. Sorry for the long winded answer, but you raised a lot of important questions and I wanted to get at some of them.

#### **Audience Member**

I was wondering if you could factor in the demographic changes in the world. As of November of last year, Japan began to lose population. Russia is losing population faster than anybody else. To such an extent that they are not sure in 2020 they'll be able to hang on to Siberia. Europe is becoming Islamified, and by the middle of the century, if demographic changes continue, trends continue, Europe will be an Islamic continent. Now all of these are going to have vast political changes on what they're willing to do and what they're able to do.

#### **Dr. Michael O'Hanlon**

Well, good point. Although on the last one I'll challenge you. But we can agree to disagree on whether Europe is going to be a Muslim continent in 20 years. But in any event, I take your broader point. And yes, I think it will be hard. I think standards have to be realistic for all these countries. In my book, what I tried to do was to juxtapose the ambitious agenda I was trying to put out there with political reality. Realizing that most of what I was saying would not be seen as politically realistic by anybody in any of these countries, but none the less, say okay, there are going to be some basic constraints. Now the Japanese, within their current defense budget, could build a ground force that could sustain 25,000 troops abroad. I have no doubt about that at all. I mean, they spend twice what the US Marine Corps does every year on their military. And the US Marine Corps could sustain 50,000 people a year. And the Japanese have the twice the budget. So, in theory, they should be able to do 100,000 a year. But let's just say 25,000. But let's be realistic, partly because of what you just said. If the Japanese built 100,000 large expeditionary force in the next five years, their neighbors really would go up in arms, because 100,000 people is actually enough to cause real trouble. So I'm suggesting let's start at a lower number where the capability is enough to make a difference in a Rwanda genocide, but not enough to go out and invade North Korea.

So that's part of what I'm trying to get at with this agenda. To lay out numbers for each country that are generally realistic, I think, in the sense that they should not be seen as overly threatening by their neighbors, and should not generally be all that expensive. So typically, Japan, South Korea, Germany, Russia, countries of

that general size and capacity, even though I just mentioned a lot of different types of countries, should probably aim for anywhere from 15,000 to 30,000 deployable troops. And if you saw most of the world's mid to large countries expand their deployable ground forces by that kind of number, you would wind up with some real serious aggregate capacity. Right now they can typically do 2,000 here, 3,000 there, and they got all sorts of legal prohibitions against deploying, or they've got to pull people out of some other kind of operation. They raise questions about their conscripts being sent overseas when it's not legally allowable.

I mean, a lot of ... part of the agenda I'm laying out, the reason why it's important to put it on the table, even though it may seem like just back of the envelope nonsense, is that only by putting out the agenda do you then get countries to say, "Well, what laws do we need to change so we can do our share?" And maybe it's easier for them to do their part if the whole world is also making an effort. Because then Japan can say to the Chinese and Koreans, "We're not doing this because of some secret desire to seize the disputed islands in the East China Sea. We're doing this because Kofi Anan and the international community at large have decided, through the Security Council and other forum, that we really should all be expanding our capacity at modest levels. Not with tanks and aircraft carriers, but with infantry troops and armored Humvees and roll-on, roll-off ships." I think politically, it's still very ambitious. I grant your point. And the demographics complicate it, and the regional politics complicate it. But I've tried to diffuse at least some of the big arguments against with this sort of share the burden kind of approach that has ambitious, but still finite demands on each country.

#### **Audience Member**

Thank you. Mark Wilcox from the Department of Joint and Multinational Operations here at CGSC. In describing the sort of light infantry force that you're mentioning, it seems clear that the mission would be basically get in, stop the fighting, stop the killing. Now the other part of the equation, of course, is the fact to create the conditions whereby this force can eventually leave, someone else is going to have to come in and do the other work, be it international organizations, Nongovernmental Organizations (NGO), etcetera. And there would seem to be some expectation that whatever force is put in will somehow provide some support to these follow-ons, whether it be security, or perhaps some kind of sustainment. What do you see as the relationship between this kind of humanitarian intervention force and those other organizations that come in and help, and is there a possible hazard that you won't bring enough sustainment in with the military force to meet the expectations of these other organizations?

#### **Dr. Michael O'Hanlon**

Yeah, that's a great question. You've probably done as good a job, implicitly, in

answering it as I can now. Yes. It's a huge constraint. We see it in the United States. My current boss, Carlos Pasqual, had the job at State of building capacity there, which we all recognized, even in our country, was badly over due. When we were lucky enough to have a chance to talk with Mr. Rumsfeld back in May, the Secretary asked Carlos how he could possibly have deserted this incredibly important position at a crucial moment, and couldn't help but tease Carlos a little bit. But we are glad at Brookings he made the decision he did. But it just goes to underscore your point, that the world doesn't have this kind of capacity. I guess we need a follow-on study to ... I took one piece of the puzzle. And you're right, by itself it wouldn't do the trick.

I have no doubt that getting security off to a good start in many of these places would be a huge improvement already over where we've been. And in some cases, make the NGOs job easier, compared to what it is now. There are a lot of NGOs trying to operate in Congo or in Darfur. They're just not able to work very well, because they've got to worry about their security most of the time. So even if we didn't get any improvement in capacity on the civilian side in the short term, I would still submit to you we would be in a better place if the global military and policing capacity were improved. But it's not really a good enough answer. Your question, I think, is right on the money, that we should envision a parallel effort to do what State is now trying to do in the US And that requires everything from police to legal advice to development assistance and so forth. And to do it in rapidly deployable ways.

Beyond that, I just agree with your argument. It was really more of, I think in many ways, more of a statement than a question, and I think you were right to point out that limitation to my argument. There's additional capacity above and beyond the military that's needed.

**Audience Member**

Colonel Jim Kauffman from Assistant Secretary of Defense for Special Operations and Low-Intensity Conflict (ASD SO/LIC) at the Pentagon. I have a question that you might comment on, reference private military companies taking up some of this additional capacity that you're advocating. Take a look at some of the examples of executive outcomes in Angola and in Sierra Leone, and then currently there are reports, or news reports anyway, that Blackwater in the United States is preparing a deployable brigade for possible employment in places like Darfur. And I'd like you to comment on what role in this capacity building that you'd see for the private military companies (PMC) and some of the obvious political difficulties with that.

**Dr. Michael O'Hanlon**

That's a great question. First, let me say most of what I was talking about was the military contractors doing training. And in some cases, you know, dangerous training. And I think to the Bosnia Train and Equip Program, operations like that. Training the Nigerians on a crash basis so they could go off to West Africa. That's mostly what I had in mind. But I take your point. There are interesting examples where you've actually seen private combat forces achieve something, which sometimes has been good, compared to the alternative. I guess ... we still, however, need to be a little nervous about that kind of operation because who's to say who's going to do it? When? And for what purpose? What if, all of a sudden, the rules are that you can go in and stop a conflict and you keep 50% of the wealth that you are able to control in the diamond producing part of Eastern Congo or something? If that's the situation, then all of a sudden, people's incentives may deteriorate compared to what they should be. There's more of a desire to go in there and drive out difficult people into a different part of the country where they don't get in the way of your diamond operation, as opposed to actually stabilizing the country.

So I think that the short answer has to be that, in most cases, these groups should not be leading operations. They should not be ultimately responsible for the success of the operation. And in some cases where they can go in and supplement a government in a specific, limited way in a given country, I'm not going to be so absolute as to say it's always a bad thing. It always makes me nervous. But compared to the alternative of sometimes seeing a conflict rage on, I'm not going to categorically say it's always wrong. But in that case, the government that brought them in has the responsibility for what they're doing. If the international community is in charge of a mission, it better have pretty clear guidelines on how these contractors vet their own soldiers, what kinds of internal discipline procedures they have for people who do inappropriate things, how they make sure they're not being used as ways to just enrich the individuals involved. It's going to have to be a lot of oversight.

My colleague, Peter Singer, has done a nice job on the kind of regulation that's needed for PMCs, and I think it's generally the best answer I can give to your question. We should always be nervous about these kinds of companies being involved in combat missions. Occasionally, it may be tolerable, but usually you'd be better to keep them in the training and equipping and logistics side of things. That's my overall take. It's probably sort of an obvious answer, but I guess the only ... it's always easier to say I'd rather not have them do this if we can avoid it, but I would admit to you, well, what if there's no other way to do the mission? And what if executive outcomes really did stop a war that probably would have continued otherwise? Well, in some cases, I'm going to judge by the results. If executive outcomes really made a positive difference in a couple of places, as I think it probably

did, then I'm not going to get too holy about saying that because they were private, therefore what they did was wrong. But they'd still make me nervous, and I'd want to make sure we had an international mechanism for transparency and monitoring. Still not a great answer, I know. It's a hard problem.

**Audience Member**

Gary Galt, Air Staff. I would like to ask you, in the case of the Liberia operation, I believe that we were supposed to support the Economic Community of West African States (ECOWAS). So what's your take on ECOWAS and how that operation went? Just what you observed.

**Dr. Michael O'Hanlon**

Probably people in the room would know the Liberia operation better than I, and you're invited to answer after I give my attempt. But I think that overall, what we saw was an organization that didn't have the capacity to do the mission it was asked to do. In this case, going back to your colleague's earlier question, it probably was an organization that just was not up to it militarily, in addition. So it was an exception. I think in most of these cases, if the mission fails, it's a lack of a good strategy or a lack of political will from the international community. But in this case, it may actually have been a mission that was just too hard for the organization being asked to do it. That's my impression, having watched this from a distance, not really being a big student of it.

So I think that what we recognized at the time, and again, if others know the mission better, feel free to correct me, is we needed somebody with a little bit more oomph and a little bit cleaner line of command and control, essentially, the Nigerian government and the Nigerian Army, to be responsible for this mission. Even if there were going to be some abuses and some imperfections, having one country that had actually done some military operations itself, and had some experience in making things happen on the ground, and had some real discipline, or at least some limited discipline of its own forces, was better than this regional patchwork organization that was trying to function as a military alliance, but which was really closer to a political association.

So that's my overall impression, that we needed to give one country more clarity of command and responsibility, unless we could find an organization like NATO to do it instead. Anybody else want to give a better answer, because some of you may be able to.

**Audience Member**

Sort of a comment/question. Some might argue that in the case of ECOWAS Monitoring Group (ECOMOG), the problem was that the Nigerians had too much power, and used it both for corrupt purposes and to increase their regional oomph. That

would seem to be a problem with this issue, that ... and I think ECOMOG might be a good example of that, with some of the problems that arose with the Nigerian forces, in particular. That if we do build capacity for countries, how do we keep them from using it for mischief? Supposedly in the name of the international community. I throw that out as a question, please.

**Dr. Michael O'Hanlon**

Yeah, it's a good question and a good observation. Let me start with the observation, though. My overall impression is that if this gave Nigeria a little more prestige in the region, it was still a small price to pay compared to the alternative, which had been eight years of one of the most wantonly cruel and ruthless wars that I've ever witnessed, at least from the distance I saw it. I mean, most wars have at least one party that you feel is acting in an immoral or inappropriate way. This war was just nuts, even by the standards of crazy militia wars. This was just ... you know, people on drugs cutting off arms of children. You know, every war can be caricatured in a somewhat over simplified, graphic way, but I think for the West African wars, that's what you had for a long time. And if the Nigerians stopped it at the price of a few corrupt soldiers doing a few inappropriate things, I'm prepared to live with it overall. And I don't think the Nigerians got unusual regional clout or benefit out of it, even if it gave them a little more stature. I would say it was stature that was generally deserved in this case. We probably could have a long conversation about that, but I'm glad for your alternative observation, just to remind us all of the complexities of any of these.

Which then gets to the broader issue of how do you wrestle with these complexities in general? Well, I think one thing you do is make sure you don't depend too much on any one country, or any small group of countries. So you don't want to make the Nigerians and the South Africans and the Kenyans the only three powers in Africa that can do this stuff. You want to build two or three brigades in as many countries as have reasonably democratic systems, or reasonably progressive governments if you can't find a democracy. That gives you some balance and also limits the numbers in any one place, so that, yes, they can still wreak mischief internally. Two or three brigades can still make a lot of trouble in their own country, and they can probably invade a neighbor and take a swathe of territory, but for the most part, I think they're going to be small enough capabilities that they're not going to be in the business of taking over each other's countries with the kinds of forces we would envision for this project. I'm talking about 10,000 well trained troops per country. I'm not suggesting we give these 10,000 troops, in all cases, C-130Js and supporting Air Forces or attack helicopters. I think in some cases, you would get back to the specialization question. You'd say let them do infantry operations with some tactical rogue mobility.



And that partially addresses your question. That in countries that make you a little nervous because they're heading in the right general direction, but they still have a volatile political system, you don't give them too much capacity to make them a big danger. But I can see your point. It's always going to be a risk. You're going to get some of these wrong. And the human rights community is sometimes going to beat up on this kind of a program. And people like me have to be willing, and people in general have to be willing, to say the benefit is greater than the occasional abuse. Because I firmly believe that's the case. If we had more countries that could stop Darfur, I think it would have been stopped two years ago. If we simply had more infantry capability. Now if you asked the Sudanese government would have said no, and the peace accord in the south would have been at risk. And there would have been a lot of political reasons we would have been nervous about being more forcible in that situation, but I still think there's a very good chance, if the world had more capacity, militarily, to do this mission, we would already be doing it. And doing it much better and saving a lot of lives.

So when I hold up that alternative vision compared to the worry about a hypothetical human rights abuse or a hypothetical occasional misuse of one of these brigades in it's own country, I'm prepared to run the risk. And we have a US military that has a lot of experience in it's School of the Americas program and other sorts of issues, IMET, in dealing with these kinds of trade offs. You don't always make the Congress happy, we don't always make the Congress happy in the choices we make, but in the world in which we live, the alternative is to tolerate Darfurs and Rwandas, and I think that's a bad choice. So all I can do is make the argument and then I think, politically, at the end of the day, if you have a few success stories to point to, it's a pretty powerful counter argument to those who would emphasize only the abuses and misuses.

**Audience Member**

What do you see, or do you have in mind particular trigger points if such a force or a resource existed? What would be the trigger points that would actuate it, given sometimes individual country's interests, perhaps, in undertaking a particular mission on their own, when their interests may conflict with the group's interest that makes the alliance?

**Dr. Michael O'Hanlon**

Right. Good question. Well, I guess the first answer would be I wouldn't create a new mechanism automatically, necessarily. To some extent, the world has a lot of mechanisms for debating the appropriateness of these sort of interventions. We're obviously still trying to figure out which mechanisms are appropriate. NATO intervened in Kosovo without UN authorization. The United States-led Coalition intervened in Iraq without a second resolution, and obviously there's been a lot

of debate about both those cases, especially the second. So we're still working through the proper approach, but I don't think there's going to be a definitive answer. I don't think this kind of a solution requires a definitive answer because what I'm proposing is not an international capability that Kofi Anan controls.

I'm proposing to give each country that wants, more capacity within its own existing armed forces, so if it chooses to contribute to a mission, it can. So we have the same debates the same way. Hopefully maybe a little better as time goes on, but basically the same mechanisms using our associations of regional states of democracies, NATO, the UN, African Union, etcetera, and then we have the capacity ultimately reside within the individual nation states who ultimately choose themselves if they want to contribute forces or not. This is not a UN force I'm proposing. So I'm glad for the chance to clarify that. I should have said that in my talk, and you've helped me make that clear. So I think, you know, ultimately using forces, always political, always requires good strategic thinking, and is always going to be controversial and difficult, and can always fail if you do it wrong. So nothing about a technical roadmap for improving capacity can change that. And I think in the end, therefore, the current mechanisms are the appropriate ones, for the most part, to use.

#### **Audience Member**

Dr. O'Hanlon, I wonder if you could comment on the implications of such a force with regard to international law, rules of war, the international criminal court (ICC) and those sorts of things. How would you ... or how would anyone decide what is appropriate and what's inappropriate before, during, and after the intervention did take place.

#### **Dr. Michael O'Hanlon**

That's an even harder question than most of them, but it's a very good question. Just like all these have been, so thank you for the challenge. I think that ... I guess, again, I'd begin with the same kind of answer I just gave which is similar rules to what we've got now are the right way to start. Because this is not an international capability, it's nation state capability aggregated, you still have the same kinds of rules in place. We can still have the same debate about the International Criminal Court we were already having. But in this case, we're talking about having a debate in reference to 50,000 well armed troops in Congo instead of 16,000 mediocre troops in Congo. So you know, if anything, as capacity improves, as oversight improves, as the sheer numbers of people on the ground improve, and more of them have been well trained, I think we'll probably get more timely notification of some of the abuses that are undoubtedly happening already and anyway.

But let me tell you, as a person who was in Zaire in '82 to '84, one of the things that people back then appreciated, at least out of Mobutu, as much as they despised many other aspects of his rule, was the stability. And yes, there were abuses. Yes, you really didn't trust the police forces and they were corrupt and they would sometimes physically mistreat people and the prisons were horrible, but at least people weren't in open conflict. And the Zaire Wah and the Congo Leh appreciated the fact that in the '80s, the society they lived in was better than the one that they had in the '60s when there was open civil war. And today, they are back to the open civil war.

I think this is a point that shapes a lot of my thinking on humanitarian intervention, and it may or may not be true in Iraq. But I think in most parts of the world, when people are faced with sheer anarchy and wanton killing, they actually will typically prefer a competent occupying force to the alternative. That's maybe a somewhat naïve comment and we're learning just how controversial an outside force can be, yet again, in Iraq. But my experience, in many of these African civil conflicts at least, is that the abuses that you're talking about that we have to make sure we prevent or use the rules of law and Geneva Conventions and ICC to prosecute when they occur are real worries, but they're not show stoppers. In fact, the kinds of debates and mechanisms we're already having and already creating are acceptable. They are good enough to allow this idea to still go forward. I wouldn't require anything new or radically different. What I want is just more well trained forces operating under proper international auspices, and I think for the most part, those forces are preferable to the alternative. So whatever answer you give me, on the ICC debate for example, I'll still want to have this capacity as compared with the alternative of mayhem and anarchy in Eastern Congo or in Darfur.

My own view, you go through the specifics that you raised, my own view on the ICC is, frankly, that I think it's a risk worth taking for the United States. I think it's probably more beneficial to us and to our interests than it is a risk to our troops. That's just my view. We could talk about that at greater length. But whether you agree with me or not, I don't think the issue rises to the level of being a show stopper for the overall need to improve capacity.

#### **Audience Member**

Dr. O'Hanlon, Bill Latham from CGSC. You mentioned the moral and strategic reasons for pursuing this course of action, and it does sound like a great idea, particularly for us out of enlightened self-interest. But it's hard to imagine the Japanese Minister of Defense waking up tomorrow morning and realizing Dr. O'Hanlon's got a great idea, we should get out our checkbook and develop this capability over the next ten years.

**Dr. Michael O’Hanlon**

I tried it on him, but I’ll tell you in a minute what he said.

**Audience Member**

Okay. If you did not come away with a sale, who do you see making this sales pitch successfully?

**Dr. Michael O’Hanlon**

I was just thinking as you said, “A couple more questions,” it’s still like four hours until the Red Sox and Royals game, so we do have time. But the way to sweet talk the Japanese this year is to remind them that they won the International Baseball Championship, because no one ever talks to them about it. And when you go to conferences in Japan these days, just bring that up and they’ll love you for the rest of the conversation. But I take your point. It may not actually translate into buying roll-on, roll-off ships. So I think the Japanese are obviously at a fascinating point in their history. Just to take that case that you raised. Shinzo Abe and many of the other top Japanese leaders are trying to sort out what they want their country to become. They do want it to be more of a normal country. There’s no doubt about that. I’m struck at how far the Japanese have evolved already in their thinking on security.

For those of you who watch them in Iraq, you may have mixed feelings. It appears they did a pretty good job on the reconstruction, but still extraordinarily tepid about ... or totally against the idea of putting their forces at risk. They’ve got a long ways to go still in their international military role. I’m not proposing that if they had 20,000 forces we should have asked them to be sent to Iraq. I’m suggesting maybe Congo would have been a good candidate for the Japanese, where the challenges are largely logistical and largely just basic competence. You know, walking the streets, providing some level of security. You might lose a couple troops doing that, but in the Congo sort of environment, I think that you would have still made a big difference, even if you had very minimal rules of engagement, limited use of force. It’s a stretch, but you know, it’s a conversation you can have with them now. And if the conversation doesn’t happen for awhile, the policies sure won’t happen either. You know, if Shinzo Abe becomes Prime Minister in a month or two, he’s going to want to pound his chest a little. He’s going to want to have some kind of a Japanese security policy that is tougher and different and more assertive than what Japan has done for 60 years. My fear is that he’ll do it over the disputed islands with the Chinese or something like that. Wouldn’t it be nice to be giving him an alternative? Now maybe peacekeeping in the forests of Congo doesn’t seem all that muscular to the Japanese public and they probably don’t get that much pleasure out of thinking of themselves as reconciling differences between different Bantu tribes 6,000 miles away, but I would still want to give it a try.

**Audience Member**

[inaudible] ripple effect on the North Koreans?

**Dr. Michael O'Hanlon**

Yeah. I mean ripple effects could work positive or negative. But I think, again, I would try to sell this as an idea that the South Koreans should be considering as well. And if the South Koreans are less and less interested in preparing for a fight with the North, the good news is their defense budget is still pretty robust and they're down sizing and modernizing their ground forces and doing a lot of smart things, as far as I can tell, even as their politics are a little bit too friendly toward the North simultaneously. But they can afford to deploy a brigade or two overseas, given where that confrontation is now. I don't think we're likely to see war at any given moment, and deterrence is pretty robust, I think. The South Koreans, together with the Japanese, together with the Chinese, could do some of this stuff. Each work to have a couple of more brigades deployable by 2015. I mean, that kind of a regional ... you know, people in Asia, for those of you who are part of Asia and security dialogues, and have spent time in that region, and I know many of you have, they're always looking for ways to give their security dialogues more meaning, more beef, more teeth, more of an equivalent to what NATO does on the other side of Eurasia. Again, they may not love this idea, but it's something real. Apart from just wondering how they're going to manage or mismanage the next dispute over disputed islands.

**Audience Member**

You know, Korea actually does have a brigade in Iraq. A brigade plus, actually. Admittedly, it is in the Kurdish region, which they searched to find a safe place before they deployed it, but it is there. It did have to convoy all the way through the rest of Iraq. It does convoy on a daily basis. And they are fairly robust in what they're doing. So they should get some credit for that. Considerable credit.

**Dr. Michael O'Hanlon**

It's remarkable that that's happened in the context of this generally tough US and Republic of Korea (ROK) relationship in the last five years, and they've still gotten their assistance there.

**Audience Member**

Sir, good afternoon. My name's Lieutenant Colonel Marcus Fielding. I'm the Australian Exchange Instructor at CGSC. You will be pleased to know that Australia is growing its light infantry capability. We're buying two ships and five C-17s. That's our small contribution to your concept. I'm not sure if you spoke to my Prime Minister on that, but I'll put it down to something. You mentioned China

just briefly a little while ago. I'd be interested to hear your perspective on whether you think China should be a player in this expeditionary capability. It's got about a million light infantrymen. Not a lot of expeditionary capability, but it's clearly a growing stakeholder in the global order. So where would you see China's role in reducing the gap?

**Dr. Michael O'Hanlon**

Well, I won't completely punt on your question, but I will begin by saying that I think our Australian friends have one of the best reads on how we should handle China of anybody in the region. I hope that dialogue continues to be strong because I think the South Koreans are inclined to be, at times, a little too friendly to China, and the Japanese are inclined to be a little too unfriendly to China and vice versa. So you live in a region where, with your strong alliance with us, and yet, your strong need to get along with China, you provide very good advice. So having said that, since you walked away from the microphone, I won't be able to ask you for your advice. I'll give you mine. You can give it ... yeah, please do.

But my overall take is two or three brigades would be fine. It would help focus their military on a different set of missions that would engage them more, create more of a stakeholder concept, to use Bob Zelick's phrase, for China's role in the broader international system. Right now, their overseas military presence seems more designed to make friends with the Chavez' and the Mugabe's of the world, with small advisory missions, etcetera. It seems more geostrategically competitive with us. This is a way to also make it somewhat cooperative.

**Audience Member**

I don't disagree. I don't understand why we don't have a division of Chinese sitting in Iraq looking after a particular sector there. It seems to me that they've got a lot of interest in making sure that that's a success story.

**Dr. Michael O'Hanlon**

Interesting. Thank you.

**Audience Member**

Good afternoon, Doctor. Tim O'Hagan from the Department of Joint and Multinational Operations here at CGSC. Question is kind of related, but it involves North Korea. Would you see excluding them from contributing capability, them or any other country? If so, what would that criteria for exclusion be?

**Dr. Michael O'Hanlon**

At the risk of offending any North Korean friends that might be in the audience, probably not a whole lot of them. I'll say that if there were any missions on the moon, the North Koreans would be great candidates because they already live

there. And I don't say that just to be ... I'm sorry, that was a little too pejorative towards them. I don't mean that they are not capable of this. I mean, they have no language skills, no international coalition skills. They live in a totally insular community, and the number of North Korean military officers who have had even five minutes of contact with our general officer corps, our colonels, I think is miniscule. I think it's the people who might accompany their ambassadors to the UN I think you need, and again, people in this room, starting with General Petraeus and many of the rest of you, know far more about this than I do, but you need some ability to work with other people. Or to use a term that you folks sometimes use, to play together nicely in the sandbox. To use the casual way of putting it. And the North Koreans can't do that right now, with anybody.

So I love the idea. Let me come back and be more serious. I love the idea. It would be great to say to the North Koreans, "Here is an idea we'd love to pursue with you, but this is one of the reasons why there'd be benefits, at least for us, to seeing you open up to the world and talk more to the world. Because right now, you can't even be in the conversation." Leave aside the language barrier, maybe we could have the South Koreans be our bridges to the North Koreans on language, if that were the only problem. But these people are just not really operating on planet Earth, in any kind of a way that the rest of us do. It's just the most insular country, by far, on the planet. So they're not capable of it now. And yet, their infantry forces, you know, in 2025, maybe even today, but their infantry force capability is probably good enough, if their officer corps can learn how to deal with the rest of the world. But that's going to take a long time. I don't know how to make it happen.

So I love your idea, but again, I think there has to be a certain amount of practice that goes into this, and a certain amount of conversation and sharing of at least officer exchanges and that sort of thing. And then preferably, some practice in the field before you do anything too extensive. And the North Koreans, of course, are totally unopen to any of that. So they can't really be a top candidate. If you disagree, I'd love to hear it, but that's my read.

#### **Audience Member**

I was just looking for criteria to allow or disallow countries ...

#### **Dr. Michael O'Hanlon**

I think anybody's allowed who ... yeah, it's good that you put it that way because I wouldn't say we should go out of our way to tell the North Koreans they're not welcome in this initiative. If they just say, "Oh, this is the one way we can talk to you constructively about some problem that doesn't divide us." Sure, we should listen to the conversation. Even if we ought to be awfully wary about their actually deploying forces anywhere. But there's no reason why we couldn't at least start to talk to them about how this should be a purpose for international forces in general,

and if someday, maybe operating with the South Koreans, they want to each contribute a couple of battalions to an integrated Korean combined brigade, why not let that conversation happen? But the purpose of it would be less to advance my agenda today, than to advance inter-Korean working together and then opening up North Korea to the outside world. So yeah, I like that aspect to your question.

**Audience Member**

I hate to let the opportunity pass up, so I'll just come in. The issue of sovereignty comes up here. Talking about with the Chinese being involved, or probably not because they really don't like people messing with sovereignty. We look at maybe the poster boy for this kind of humanitarian intervention, allied force was done in violation of the sovereignty of the state involved. How much do you see that as being a problem for pulling countries together to get involved? To provide a capacity and to get involved in these sorts of operations?

**Dr. Michael O'Hanlon**

That's part of the benefit of proposing this as a way of increasing individual nation state capacity. Viewing questions like the very good one you raised, as essentially separate questions. In other words, we can still have our previous positions on sovereignty and what kind of mechanisms are needed to legitimate the deployment of a force. The Chinese can still refuse to deploy to any Chapter VII operation that would infringe upon the sovereignty of the country in question. So if the Chinese wanted to be part of this, they might agree to go to Congo, where there is a basic agreement with the government that the international force should be there. It's not a forcible imposition of military capability. It's a cooperative effort where the international forces are doing something the government and Kinshasa wants to see happen but can't do itself. The Chinese might be willing to do that. In fact, they've been in Congo before and places like that.

So I think that's where you have to allow individual states, ultimately, to make their own decisions about which operations they're going to contribute forces to and which ones they're going to sit out. And that's part of the reason why I prefer to do this at the nation state level. Create the capacity at the nation state level, instead of trying to get all these questions to be impediments to even getting down to square one on the idea. Because if you created an international capability that Kofi Anan could deploy with the permission of the Security Council, maybe the Chinese could live with that because they have a veto, but other countries might not be able to live with that. So you don't want to have most of the force be at Kofi Anan's fingertips. He's not the deploying commander. The deploying commander is ultimately the President and the General of whatever country you're talking about, as they decide whether to be part of an operation or not. I would hope that would address a lot of the concern.



**Lieutenant General David H. Petraeus**

Now, what some of you may have picked up ... hang on here, is that Michael and I went to the same graduate school. So we're products of the great Woodrow Wilson School of Public and International Affairs. And that university has a wonderful model called "In the Nations' Service." A lot of good Princetonians take that pretty seriously, and Michael is among them. So we thought that an appropriate gift to him would be, also, a copy of a book that talks about service. In fact, three centuries of service, which is what this great historic post has rendered to our country. So to one who is also in the nation's service, we thank you for a great presentation here, and we thank you, more importantly, for all you've done in recent decades and will continue to do in the years ahead. Thanks very much.

**Dr. Michael O'Hanlon**

Thanks, General. He did his Ph.D. in half the time it took me, by the way. We started together.



## **Security Assistance and Counterinsurgency: The British Experience in Oman, 1964-1975\***

**Walter C. Ladwig III—Merton College, Oxford**

This paper examines the British security assistance effort to Oman during the “Dhofar Rebellion.” From 1964 to 1975, the British-backed Sultanate of Oman waged an ultimately successful counterinsurgency campaign against Marxist rebels belonging to the Popular Front for the Liberation of the Occupied Arabian Gulf (PFLOAG). Like the US experience in El Salvador, the Dhofar Rebellion was a case where, due to political constraints, only a small number of British officers and Special Forces trainers were dispatched to train and advise the host nation’s armed forces in resisting a foreign-backed insurgency. Though little studied outside of the United Kingdom, the Dhofar Rebellion has been praised as “probably the best conducted counterinsurgency campaign ever fought.”<sup>1</sup> It has even displaced the famous Malayan Emergency as the standard case study for the British Army’s Junior Command and Staff Course.<sup>2</sup>

Since the 2006 Quadrennial Defense Review has put increased emphasis on the expansion of US Special Operations Forces for the purposes of training and developing foreign counterinsurgency forces, the lessons from this successful effort to provide security assistance to a nation in the midst of an insurgency could have value for US military leaders and policy makers alike.

This paper is divided into six sections. The first section provides a discussion of the physical and political situation in Oman during the period in question, followed by a brief overview of the insurgents, particularly the Popular Front for the Liberation of the Occupied Arabian Gulf. Section three discusses in detail the composition and many short comings of the Sultan’s Armed Forces (SAF). The British assistance effort to Oman is taken up in section four. After an outline of the British-assisted Omani counterinsurgency campaign in section five, the paper concludes with an assessment of the British efforts and notes several points that have broader applicability for security assistance in future counterinsurgency campaigns.

\*Please do not cite without the explicit permission of the author

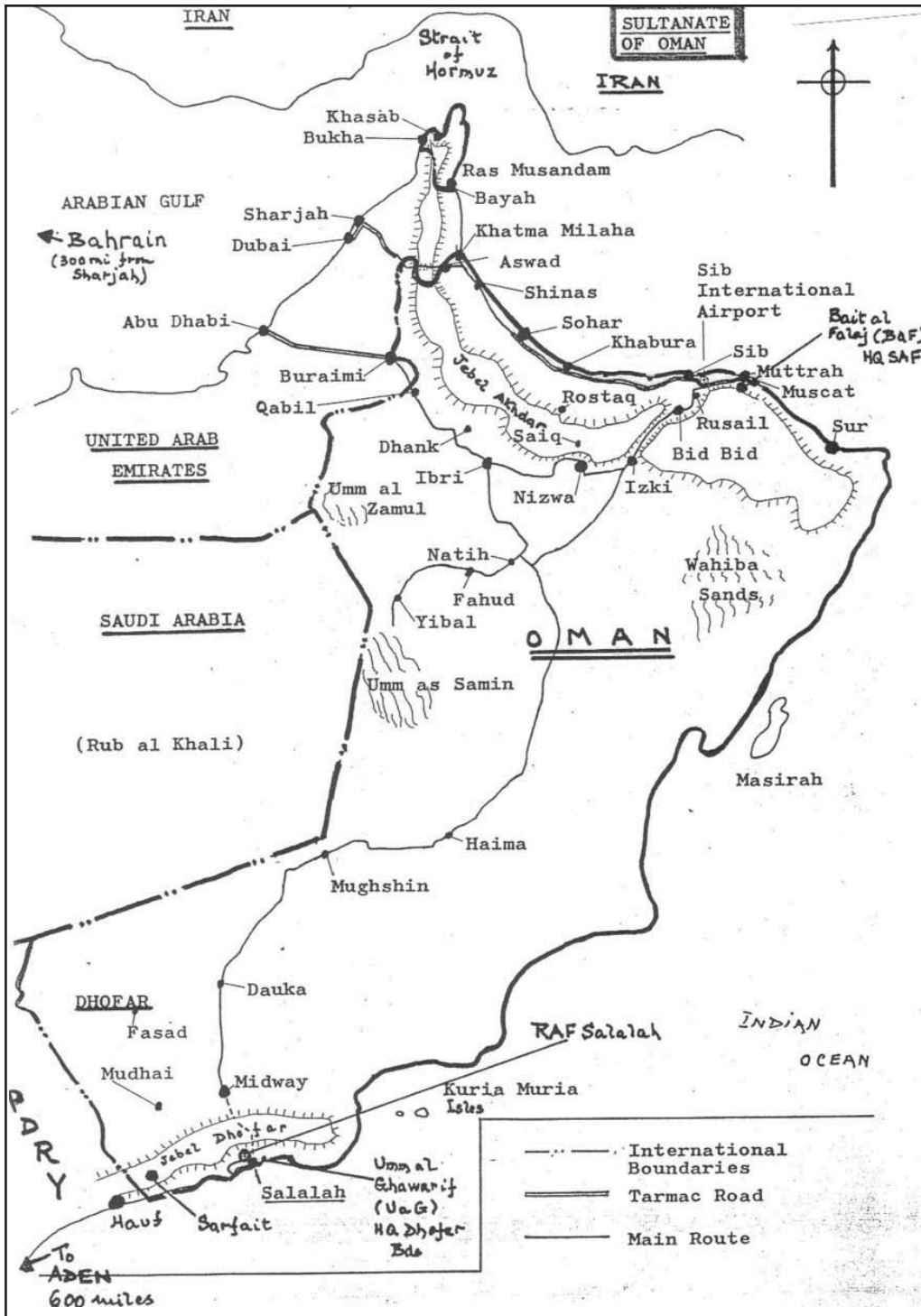

CSAF's MAP OF OMAN CIRCA 1970 FROM THE PAPERS OF J.D.C. GRAHAM

## The Physical and Political Environment

*“If your path is blocked by a snake and a Dhofari, kill the Dhofari first.”*

—Northern Omani saying

Situated in the southwest corner of the Arabian Peninsula, the Sultanate of Oman is bordered by the United Arab Emirates on the north, Saudi Arabia on the west and Yemen to the southwest. Oman is strategically located adjacent to the mouth of the Strait of Hormuz—the vital waterway through which oil from the Gulf makes its way to market. Part of the deep water channel through which oil tankers transit the strait actually lies in Omani territorial waters.<sup>3</sup> With a population of nearly half a million in the mid-1960s, the majority of Omanis lived in the northeast of the country on a coastal plain that included the capital of Muscat. While most of the population in northern Oman was Arab, a sizeable minority of Baluch settlers from Gwadar in Pakistan (which was owned by the Sultan of Oman until 1958) lived in Muscat and the coastal areas.

Five hundred miles southwest of the main population center of Oman lies the province of Dhofar. Linked to Muscat by a single graded but unpaved road, Dhofar has been described as an island, with the Arabian Sea to the south and a vast expanse of desert that eventually links to Saudi Arabia’s Empty Quarter to the north. The only major towns in Dhofar, including the provincial capital of Salalah, are located in a tropical coastal strip thirty-seven miles long and nine miles deep that is capable of sustaining vegetation due to the monsoon that visits the area between June and September.

Separating the lush coastal plain from the desert is a 150-mile long plateau known as the Dhofar Jebel. The most significant geographic feature in Dhofar, the Jebel rises steeply from the coast to a height of over 3,000 feet in some locations. The Midway Road, the only route linking Dhofar to the rest of Oman in the early 1960s, ran across the Jebel. Despite its foreboding geography, the Jebel was inhabited by nearly 10,000 nomadic herders who made their homes there according to the season. Ethnically distinct from both Northern Omanis and the coastal inhabitants of Dhofar, and speaking a language closer to Aramaic than Arabic, the Jebelis were an independent people with little regard for the Sultan of Oman. Life on the Jebel was difficult and tribes living there constantly fought each other for access to water and grazing land for their herds. In Jebeli society, all men carried rifles “as a badge of masculinity and status as well as for protection.”<sup>4</sup>

From a military standpoint, the environment of Dhofar made operations in the province extremely difficult. The annual monsoon, combined with the lack of

“finished” roads, hindered the mobility of the Sultan’s forces and prevented the use of air support nearly four months out of the year.<sup>5</sup> A side effect of the monsoon was a heavy rolling surf along the entire coast of Dhofar that made it nearly impossible to land boats on the shore, even outside of monsoon season.<sup>6</sup> The rough terrain of the Jebel became the primary battleground for the insurgents as many of the advantages that the Sultan’s conventional forces possessed in open terrain—such as superior mobility, employment of heavy weapons, and the ability to concentrate forces—were ineffectual on the high plateau. On the Jebel itself, the hunt for water dominated most aspects of life. The need for water limited the mobility and flexibility of the Sultan’s forces: The scarcity of potable water sources limited the number of available base camps, while the range of patrols was constrained by the amount of water that could be carried.

The political environment of Dhofar was as daunting for a counterinsurgency campaign as the physical environment. Oman of the mid-1960s could charitably be called a medieval state. Basic health care and education were lacking. The country’s single hospital struggled to treat endemic malaria, trachoma, and glaucoma while none of the three state-run schools in Oman offered an education beyond the primary level.<sup>7</sup> The Sultan of Oman, Said bin Tamur, ruled like a feudal lord: No Omani was allowed to leave the country, or even his home village, without the Sultan’s explicit permission. He banned all symbols “of the decadent 20<sup>th</sup> century...from medical drugs and spectacles to books and radios” and he flogged his subjects for adopting Western dress.<sup>8</sup> Dhofar was the Sultan’s personal domain, where he resided in seclusion year round, despite the fact that the nation’s capital was 500 miles north in Muscat. Although he took a Dhofari wife, who was the mother of his son, the Sultan disliked and distrusted his Dhofari subjects, the Jebelis most of all.

The Sultanate’s diplomatic relations with the outside world were limited to Britain, America, and India.<sup>9</sup> Of these three, the most notable relationship was a treaty of friendship between Oman and the United Kingdom that dated to 1800. As part the agreements between the two countries, the British Royal Air Force had access to an air base at Salalah in Dhofar in return for maintaining and operating the facilities.

The Sultanate faced a number of challenges to its external and internal security in the decade leading up to the Dhofar Rebellion. The Sultans of Oman had warred with Wahhabists on the Arabian Peninsula for centuries, most recently in a border dispute with Saudi Arabia (the successors of the Wahhabi) over control of the Buraimi Oasis. Having been defeated in their attempts to seize the disputed ter-

ritory in 1952, the Saudis looked for any opportunity to undermine the Sultanate. That opportunity was not long in coming.

In 1958, the Imam Ghalib bin Ali, the traditional spiritual leader of the tribes of the interior of Oman, and six hundred of his armed followers launched a rebellion against the Sultan. Occupying a strategic mountaintop position that allowed them to dominate all of Northern Oman, the Saudi-backed insurgents were only defeated thanks to the intervention of the British. The defeat of the Imam did not end the threat of rebellion in northern Oman. Many of the Imam's supporters escaped to exile in Saudi Arabia, while Sultan Said's reliance on British support earned him the enmity of proponents of Arab Nationalism such as Egypt.

### **A Revolution Hijacked**

The subsequent uprising in Dhofar was a classic example of a nationalist rebellion based on legitimate grievances that was taken over by radical Marxists for their own purposes. The revolt against the Sultan began in 1963 when Mussalim bin Nufl, a disgruntled former member of the Sultan's household, led a group of fellow Dhofari tribesmen in an attack on the camp of MECOM oil—an American firm exploring for oil in the desert north of the Jebel. After destroying a vehicle and shooting a local security guard, the group fled to Saudi Arabia—but not for long. Having received arms and supplies from the Saudis and military training in Iraq, bin-Nufl and fifty of his followers returned to Oman in 1964 as the Dhofar Liberation Front (DLF), dedicated to freeing “Dhofar for the Dhofaris.”<sup>10</sup>

Over the next few years, the DLF staged a number of operations, including mining the Midway Road, attacking MECOM facilities, destroying vehicles belonging to the RAF base at Salalah and—most daring—organizing a failed attempt to assassinate the Sultan.<sup>11</sup> Belatedly recognizing the threat that revolutionary groups such as the DLF posed to “traditional monarchs generally,” King Faisal cut Saudi support to the group.<sup>12</sup> Despite their ability to operate unhindered on the Jebel, without external support, the DLF lacked the strength to decisively defeat the Sultan's forces in Dhofar. By 1967, the situation in Dhofar appeared headed for a long-term stalemate. However, the state of affairs quickly changed due to events in neighboring Yemen.

When the British left Aden in November 1967, the area rapidly fell under the control of the Marxist-oriented Front for the Liberation of South Yemen, which founded the People's Democratic Republic of Yemen (PDRY). Inspired by their apparent success in driving out the British, the new Yemeni government turned its attention to neighboring Oman. Through a support base established in the Yemeni

village of Hauf, large amounts of Chinese and Russian weapons flowed to the Dhofari insurgents. With them came advisors, support, and an enthusiastic cadre of true believers dedicated to spreading Marxist revolution throughout the Gulf. Chinese agents provided training and indoctrination while 250 regular soldiers from the PDRY operated in the border region.<sup>13</sup>

By late 1968, the nature of the insurgency in Oman had changed dramatically. Bin Nufl and his nationalists were forced out of the leadership and the movement was renamed the Popular Front for the Liberation of the Occupied Arabian Gulf (PFLOAG).<sup>14</sup> Expanding its goal beyond Oman, this new organization sought to unify all of the Arabian emirates into a single socialist state.<sup>15</sup>

The military wing of PFLOAG was capable of putting 2,000 fighters into the field for offensive operations and had another 3,000 militia members on the Jebel capable of defending the insurgents' "liberated areas." Altogether, the number of armed insurgents in Dhofar eclipsed the total number of men under arms in the Sultan's forces throughout Oman.<sup>16</sup> Many of the Dhofari insurgents were experienced fighters, having previously served abroad in the Kuwaiti Police or the Trucial Oman Scouts. The best among them were sent to China for specialized military training at the Anti-Imperialist School in Beijing.<sup>17</sup>

The insurgents divided Dhofar into three zones, East, West and Center, and each had an under-strength regiment of fighters. The basic operational unit was a company-sized grouping of 100 men with organic heavy weapons. Lavishly equipped by their Communist patrons, PFLOAG riflemen carried Kalashnikovs while fire support consisted of machine guns, 60mm and 81mm mortars, RPG-7 antitank grenade launchers, 122mm Katyusha rockets and SA-7 anti-aircraft missiles.<sup>18</sup> Man-for-man the insurgents were easily the equal of their opponents. As a former British brigade commander recalls, "with anything like fair odds [the insurgents] would usually come off best in contact with the SAF."<sup>19</sup>

By the spring of 1970, the PFLOAG had established itself across the Jebel and had successfully cut off the Midway Road, severing the only link between Dhofar and the rest of Oman. Those Dhofari civilians who were not actively supporting the insurgents showed no affection for the Sultan. The Sultan's forces were forced off the Jebel and the insurgents were able to regularly shell the RAF base at Salalah with impunity. In the words of one senior British officer, "the outlook was not encouraging..."<sup>20</sup>



## **An Unready Army**

The Sultan's Armed Forces (SAF) of the 1960s were in no position to defeat the insurgency in Dhofar. Following the suppression of the Imam's uprising in 1958, the SAF had been reorganized to conduct internal defense missions in the north of Oman. A force of 2,000 men under arms, the SAF consisted of two infantry battalions and a small gendarmerie that patrolled the border with Abu Dhabi. The SAF was not equipped or prepared to conduct operations in Dhofar across 600 miles of desert, nor was it allowed to: The Sultan had decreed that security in Dhofar would be provided solely by the Dhofar Force, a company-sized private bodyguard led by a Pakistani Lieutenant-Colonel.

### *Force Composition*

After the conclusion of the 1958 campaign, the British agreed to the Sultan's request to provide a limited number of seconded and contracted British officers to lead the SAF. At the highest levels, command of the SAF was convoluted. The forces themselves were led by the Commander Sultan's Armed Forces (CSAF), a seconded British officer to whom the commanders of the Sultan of Oman's Air Force (SOAF) and the Sultan of Oman's Navy (SON) were subordinate. However, the Sultan residing in Dhofar remained the Commander-in-Chief of all armed forces in Oman. He communicated orders and instructions to the CSAF via his Military Secretary, a retired British Brigadier based in Muscat, who spoke to the Sultan once a week on the radio-telephone.<sup>21</sup>

The composition of the SAF itself was multi-national. The rank and file was a mix of locally recruited Omani Arabs and Baluchs with an equal number of Makran Baluchs recruited from Gwador in Pakistan. Due to the Sultan's reluctance to provide educational opportunities for his subjects, the majority of soldiers were illiterate upon enlistment.<sup>22</sup> Platoons were commanded by Arab or Baluch Staff Sergeants who had been promoted from the ranks. A very small number of locals were promoted to officer ranks, but these men were not allowed to command troops and were prevented by law from rising above the rank of Lieutenant.<sup>23</sup>

The lack of Omanis with sufficient military or educational training meant that the Sultan's Armed Forces had to rely heavily on expatriate officers. British officers commanded the infantry battalions, as well as units such as the nascent artillery and signal troops, while all battalion headquarters were assigned four British staff officers.<sup>24</sup> Each rifle company had three British captains, but a combination of sickness, wounds and leave usually left only two available for operations at any one time. As former CSAF Major General J.D.C. Graham points out, "rifle companies tended to operate in two halves, each commanded by a single British Officer

who, among his other preoccupations, had to control the mortar and artillery fire and air strikes.”<sup>25</sup>

Support functions for the SAF, such as supply, transport, and clerical duties, were carried out under the supervision of junior commissioned officers seconded from the Pakistani Army. Technical support for intelligence, signals and mechanical functions were supplied by seconded British and Pakistani non-commissioned officers.<sup>26</sup>

### *Equipment*

Equipment for infantrymen in the SAF was basic and of low quality. Most gear was unsuitable for the rough conditions of Dhofar: Cheap desert boots cracked within days and clothing rotted away during the monsoon season. Uniforms with “the seats of their trousers and backs of their shirts worn through” and canvas gym shoes “torn and out at the sides and virtually held on by string” were the norm for the enlisted ranks.<sup>27</sup> Moreover, the SAF uniforms, with their sandy khaki color intended for operations in the deserts of northern Oman, were said to “stand out a mile” on the green and brown terrain of the Jebel.<sup>28</sup>

SAF riflemen were armed with .303 bolt-action British Enfield rifles and fire support consisted of World War II-era Bren light machine guns, 3 inch mortars and obsolete 5.5 inch artillery pieces. “In terms of range and weight of fire,” the SAF infantry were outgunned by the PFLOAG.<sup>29</sup>

### *Air Force*

Air support by the Sultan of Oman’s Air Force (SOAF) consisted of a small number of strike aircraft and four Beaver cargo planes with a capacity of less than a ton—with the majority forward deployed at RAF Salalah.<sup>30</sup> Ten Royal Air Force (RAF) officers seconded to the Sultan’s service made the Air Force run. In the early stages of the war, systematic air support for infantry operations did not exist.<sup>31</sup> Unlike their seconded infantry counterparts who attended ten weeks of colloquial Arabic training prior to arriving in Oman, RAF pilots did not attend language courses before joining the Sultan’s service. As a result, since few of the Omani Arabs and Baluchs spoke English, if ground troops were in contact with the enemy without a British officer present, there was no way to coordinate Air Force fire support.

### *Intelligence*

By late 1964, the insurgency in Dhofar had grown to the point where the Sultan was forced to reverse himself and order the Sultan's Armed Force into the province. Since operations outside of Northern Oman had never been part of the SAF's responsibilities, it was not prepared for the task. The first armed reconnaissance of Dhofar, an area the size of the State of New Jersey, had to be conducted without proper maps of the province because the SAF had none.<sup>32</sup> Colonel A.D. Lewis, CSAF from 1964-1967, recounts the scope of the challenge:

I was therefore faced with a problem far greater than any military staff college could invent. I had been asked to move a force by an unknown route across 600 miles of desert to a country also unknown to us, as big as Wales but of worse terrain. I was to search out a rebel force that lived in the inhospitable Jebel country north of the Salalah plain about whom I knew nothing.<sup>33</sup>

Detailed information on Dhofar was slow in coming. A British officer operating in the province four years after the initial reconnaissance recalls being issued "a set of maps of the mountains, quite unlike any maps I had seen before, being 0.63 inches to the mile. There were very few place names and most of those that were had the words, 'Position Approximate' or simply a question mark, in brackets beside them."<sup>34</sup>

These difficulties were further compounded by a lack of any useful intelligence assets. There was no police force in Dhofar, and therefore no Special Branch (political intelligence) to provide detailed local knowledge to the Sultan's forces.<sup>35</sup> Furthermore, the SAF did not contain any Dhofaris and was viewed by much of the local population as "a virtual army of occupation."<sup>36</sup> The Sultan did not help matters when he ordered the CSAF not to bring any intelligence officers to Dhofar. This order was wisely ignored and a small intelligence cell was established in Dhofar, but useful information was hard to come by.

### *Counterinsurgency Strategy*

Whereas many counterinsurgency campaigns feature some form of "hearts and minds" campaign to win public support or secure the defection of rebels to the government side (both important sources of information), Sultan Said refused to sanction any program that showed leniency toward his rebellious subjects. The only tool to be employed by the SAF against the insurgents was repression. Under the Sultan's orders, wells were cemented over, homes of suspected insurgents were burned, and civilians from the Jebel were denied access to the markets in the towns on the plain where they traditionally sold their livestock. The execution

of these measures virtually forced the uncommitted Dhofari population into the rebel's arms.<sup>37</sup>

### *Medical Care*

The SAF's medical care was as deficient as the intelligence support and its counterinsurgency strategy. The SAF had a single surgeon, seconded from the Pakistani Air Force, but he had no facilities for surgery and his contract forbade him from deploying into areas with active operations. Oman's sole hospital was in Muscat, 600 miles from Dhofar. Moderately wounded SAF personnel could be sent to the capital for treatment, evacuated either by a three-day drive across the desert or by aircraft if one was available.<sup>38</sup> For severely wounded soldiers, the best the SAF medical staff could do was keep them alive with drugs and blood plasma until they could be transported to a surgical facility, the closest being the British Forces Hospital in Bahrain. Due to the scarcity of transport aircraft in the SOAF, requests had to be made to the RAF to transport serious casualties from Dhofar to Bahrain.

The lack of helicopters in the SOAF resulted in the most primitive system of casualty evacuation. Case in point: While on a patrol, Major Richard John was shot and severely wounded. It took twelve hours to evacuate him, by donkey, to the nearest flat plain where he could be extracted by aircraft, but the morphine supply on hand lasted only for three hours. After receiving a field dressing for his wound, he was "loaded on to an RAF plane and finally received the first necessary surgery some 900 miles and 36 hours after being wounded."<sup>39</sup>

### *Limited Operational Capacity*

In order to meet the insurgent threat, the Sultan's British advisors urged him to expand the SAF, but he refused. More troops cost more money and Sultan Said intended to end the conflict while spending as little money as possible. In the first few years of the war, the SAF was able to deploy only two companies in Dhofar at any one time. As a result, SAF sweep operations designed to harry the insurgents gained little of long-term value as the SAF lacked the manpower to secure the swept areas.

In addition to the lack of numbers, forces deployed to Dhofar were limited by two other factors. The first was the inability of the SAF logistical system to support any more troops in the rough terrain of Dhofar. As Col. Lewis recounts:

The two companies were dispersed widely into six locations which had to be supplied by the two Beavers we had to give them on this

occasion. Jerricans of water, boxes of ammunition, food and radio batteries were free-dropped at low levels using our own primitive methods of padding these items to prevent them from bursting upon impact with the ground. Soldiers had to exist on half a gallon of water per day, as in the Western Desert in World War II.<sup>40</sup>

The second limitation was imposed by the Sultan. Paranoid about the prospect of another uprising in northern Oman, he mandated that at least one battalion of the SAF remain in the north at all times.

Units were deployed to Dhofar for 9 months and then spent 18 months in the north on garrison duty. The problem with this arrangement was that most contract officers were only committed to 18 month tours with the SAF, while seconded officers served the Sultan for 24 months. As a result, officers with combat experience in Dhofar were not necessarily still with a unit when it returned to Dhofar a year and a half later. The lack of continuity in many command positions led some to comment that the SAF did not have six years of experience in Dhofar, rather it had one year of experience six times.

### *Stumbling Toward Defeat*

Despite the fact that the Sultan eventually agreed to raise an additional infantry battalion, the war was clearly going the insurgents' way. By 1970, the only parts of Dhofar under the Sultan's control were the towns of Taqa, Salalah and Mirbat.<sup>41</sup> An internal SAF assessment of the situation highlighted shortcomings of the government's strategy in Dhofar:<sup>42</sup>

SAF OVERALL AIM Purely military: TO KILL THE ENEMY. No political aim aside from unconditional surrender, therefore no political or civil aids to the war. None of the established civil measures for counterinsurgency exist.

- a. No police or Special Branch
- b. No resettlement of the population
- c. Scant food control
- d. No surrender or amnesty terms
- e. No psyops or propaganda
- f. No hearts and minds
- g. No civil govt on the Jebel
- h. Comparatively little intelligence

Sultan Said's fears of a northern uprising proved justified in June 1970 when a group calling itself the National Democratic Front for the Liberation of Oman and the Arabian Gulf attacked several northern towns. Although they were quickly defeated, the revolt made it clear how isolated and unpopular Sultan Said was. On 23 July 1970, with the assistance of a group of British officers, Qaboos bin Said, the Sultan's Sandhurst-educated son, overthrew his father in a bloodless coup. Across Oman, Sultan Qaboos' accession was instantly met with great rejoicing.<sup>43</sup> After the coup, the character of the counterinsurgency campaign changed decisively.

### **Assisting Counterinsurgency**

Although Britain had treaties of friendship with the Sultan of Oman dating back to the early 1800s and the British Army had been providing officers to the SAF since 1958, significant military assistance did not occur until after Sultan Qaboos overthrew his father. Requests for assistance that had previously been stonewalled in London were quickly approved to support the new reform-minded Sultan. Politically, British assistance to Oman faced a number of constraints. The Labour government of Harold Wilson, in power during the first part of the rebellion, was overseeing a major drawdown of British forces from the Gulf and had no desire to be seen as engaging in a neo-colonial enterprise, particularly on behalf of someone as repressive as Sultan Said. Ted Heath's conservative government, elected a month before the coup, was more inclined to intervention, but soon found that increasing unrest in Northern Ireland was draining available political and military resources. As a result, even at its height, the entire assistance team in Oman remained fairly small: 150 active duty officers seconded to the SAF, another 300 contract officers, and two squadrons of the Special Air Service that operated under the pseudonym of the British Army Training Team (BATT).<sup>44</sup>

The guiding principle of the British support strategy was to provide "breathing room" for the Sultan's forces to develop to the point where they could win against the PFLOAG. Britain would not win the war for Oman, and under no circumstances would British combat troops be deployed. Furthermore, with the exception of the SAS, whose participation was shrouded in secrecy, "formed units" were not directly deployed for service in Dhofar. British personnel were seconded or deployed as individuals.

Close coordination between the Sultan's forces and the British government occurred at the country team level. The CSAF met daily with the British embassy's defense attaché, and weekly on an informal basis with the British ambassador. This system was adopted to deflect criticism that the British Commander of the Sultan's Forces meeting daily with the British ambassador was a clear indication that Lon-

don was really running the show in Oman.<sup>45</sup> However, the ambassador spent time visiting the Sultan's units in the field and was a keen advocate to the Foreign and Commonwealth Office and the Ministry of Defense on the SAF's behalf.

In their support to Oman, the British provided assistance in four key areas: developing a plan for victory; training and expanding the Sultan's Armed Forces; providing experienced leadership and technical skills; and equipping the SAF for counterinsurgency.

### *Victory Plan*

When it became clear in 1970 that British involvement in Oman was going to increase, the commander of the 22<sup>nd</sup> Special Air Service Regiment, Lieutenant Colonel John Watts, conducted a survey of Dhofar and was shocked by the heavy-handed tactics employed by Sultan Said against the Dhofaris. Based on past British experience with successful counterinsurgency operations in Malaya, Watts created a five-point plan for victory in Dhofar:

1. A medical campaign to provide basic medical and dental care to Dhofaris, including those living on the Jebel.
2. A veterinary campaign to increase agricultural yields and provide fresh water for the Dhofaris' livestock.
3. An organized intelligence operation.
4. An information campaign designed to counteract communist propaganda and to persuade rebels to change sides.
5. The recruitment and training of Dhofari soldiers to fight for the Sultan.

Civil assistance tasks were purposefully given precedence over military tasks in Watts' formulation. He also emphasized that the past practices of indiscriminate reprisals against civilians on the Jebel had to end.<sup>46</sup>

This strategy was embraced by Sultan Qaboos and money began to flow from the royal treasury to civil development projects in Dhofar. Between the costs of civil aid and military operations, the war in Dhofar was soon consuming 50 percent of Oman's GDP.

To help execute the civil development aspect of Watts' strategy, the Special Air Service helped form Civil Aid Teams (CATs) that sought to provide the civilian population with tangible benefits that could win them to the government's side. CAT efforts ranged from the provision of simple medical care to the creation of a model farm that taught Dhofaris how to improve crop and livestock yields.<sup>47</sup>

## *Training and Expanding the SAF*

### Training New Recruits and Technicians

Upon assuming power, Sultan Qaboos set about expanding the Sultan's Armed Forces. He authorized the raising of new infantry regiments as well as guard units that could undertake static protection missions. Additional resources were provided to the artillery regiment and the armored car squadron and additional aircraft (including helicopters) were purchased for the Air Force. Before the coup, in 1970, the SAF numbered 3,000 men under arms; less than two years later that number had passed 10,000. Tripling the size of the SAF required additional personnel for the SAF Training Regiment, so an experienced training officer and eight NCOs were detached from British battalions stationed in Bahrain and Cyprus and sent to Oman.<sup>48</sup> Rather than deploy trainers on a rotating three-month basis—as had happened in the past—these instructors were seconded on a longer-term basis, which allowed continuity in the training efforts and permitted the trainers to further develop language skills.<sup>49</sup>

SAF recruits received six months of basic training that included instruction in rudimentary reading and writing in Arabic. Training schemes for Omanis in technical functions such as medicine and mechanical engineering were also established within the SAF.<sup>50</sup> Given the widespread illiteracy in Oman, a boy's school was started to provide a source of educated recruits for the SAF's technical support branches.

### Training an Officer Corps

With an eye toward the future, the British trainers assisting the SAF helped develop proper professional training courses so Omani (Arab and Baluch) officers could progress beyond the rank of lieutenant.<sup>51</sup> Practical training programs in map reading, small unit tactics, signals, and unit administration were created to prepare local officers for promotion to the ranks of captain and major.<sup>52</sup> A proper career structure for Omani officers was also established. The first group of 21 Omani officer candidates was commissioned in late 1971, and by the end of 1972 almost a hundred Arab and Baluch officers had been commissioned or sent to attend military academies in the UK or Jordan.<sup>53</sup>

### Operational Training

Training support was not supplied just to new recruits. The SAS, acting as the British Army Training Team, conducted exercises and drills for the rifle companies of the battalions preparing to deploy to Dhofar. Six years of indecisive clashes with



the insurgents, who inflicted casualties on the SAF while appearing to grow in strength, combined with an inability to hold territory on the Jebel, had infected a number of junior officers and enlisted personnel with “Jebelitis”—a defeatist belief that the Jebel couldn’t be conquered. To counteract this attitude, 40 SAS trainers provided extensive programs of live fire exercises, close quarter battle drills, night patrolling and other techniques required for “fighting in bush country.”<sup>54</sup> Emphasis was put on instructing the Omani NCOs, who were the platoon leaders, in the command and tactical handling of infantry sections.<sup>55</sup>

### The Firqat

One of the most significant contributions made by British support elements was the raising of irregular militia from among the tribes of Dhofar to fight on behalf of the Sultan. Previous attempts to recruit Dhofaris into the Sultan’s service were met with such a degree of failure that one CSAF remarked, “The Dhofari seems reluctant to volunteer for any service or employment whatsoever. He is considered by many of us to be the most selfish, idle and volatile creature we have ever encountered.”<sup>56</sup>

The *firqat* were platoon to company-sized units of tribal fighters that were built around a core of 6 to 10 SAS personnel who provided command and control functions as well as medical aid, organic fire support (machine gun and mortar), and coordination with artillery and air strikes. Drawing their membership from some of the very same tribes that were supporting the PFLOAG, the *firqat* provided a critical source of local knowledge and intelligence for an army that contained few Dhofaris, let alone Jebelis.

Regular SAF personnel did not possess the temperament or the training to manage the *firqat*, who could be tenacious fighters when they wanted to fight, but had social customs that were not in keeping with traditional military discipline: They didn’t like to operate outside of their own tribal areas; they felt they had the right to vote on any major decision (including electing their unit leaders); and they saw nothing wrong with refusing to take part in an operation or comply with a decision with which they did not agree.<sup>57</sup> However, the SAS, with their experience in employing indigenous irregular forces in Malaya and Borneo, were able to turn the irregular *firqat* into first-rate soldiers. Eventually numbering over 2,000, the *firqat* functioned not only as scouts and guides for SAF operations, but also as “home guards,” consolidating and defending tribal areas on the Jebel after they had been swept clean of insurgents by the SAF.

## *Leadership and Technical Skills*

### Unit Leadership

The expansion of the SAF increased the demand for company-grade British officers to provide small-unit leadership. Continuing the role they had played since 1958, contract and seconded British officers filled these leadership roles. Both the British Army as a whole, as well as a number of the individuals assigned to Oman, had experience in leading non-Western soldiers: particularly Arabs and Baluchs. Methods of command suited for the British Army required modification for the Sultan's forces: It required "careful handling and encouragement blended with the occasional tough word to get the best from Omani and Baluch soldiers."<sup>58</sup> The presence of experienced officers who knew how to adapt themselves to the customs of the local troops eased the potential problems of commanding a multi-ethnic force such as the SAF.

The provision of additional officers allowed the Sultan's army to improve its command and control in Dhofar. A permanent SAF headquarters unit was established at RAF Salalah and it was given operational control over all SAF units, including the Air Force (SOAF) and Navy (SON), assigned to the province. For the first time, the counterinsurgency operations in Dhofar had continuity of leadership.

### Medical Aid

The meager ability of the armed forces to treat battle casualties was bolstered by the deployment of a British Field Surgical Team (FST), which consisted of three surgeons assisted by a team of nurses and technicians, to RAF Salalah to treat battle casualties in theater. Not only did the FST transform the recovery rate for wounded SAF personnel, but also the mere presence of skilled surgeons in Dhofar had a significant impact. As a former commander of the Dhofar headquarters noted, "Their contribution to the morale of the whole force was beyond price. The knowledge that anyone who was hurt would be flown to Salalah for expert surgery and resuscitation, usually within half an hour of being hit, must have been a factor in the bravery shown by so many people."<sup>59</sup> The FST also provided treatment to Dhofaris at a new public hospital opened in Dhofar as part of Lieutenant Colonel Watts' counterinsurgency strategy.

### Intelligence

Intelligence support to the SAF in Dhofar was provided by an SAS intelligence troop. Establishing themselves in the major towns in the province, 25 SAS

intelligence personnel went to ground among the locals and employed their training to cultivate native contacts and information sources.<sup>60</sup> Disparate pieces of information from across Dhofar were fed back to the two NCOs of the coordination cell.<sup>61</sup> Within a few months of arriving, the intelligence troop was able to assemble “an enemy order of battle showing unit names, boundaries, personalities and re-supply routes in unprecedented detail,” information that had eluded the SAF for the first six years of the conflict.<sup>62</sup> As the *firqat* bands grew, and more and more Dhofaris came over to the Sultan’s side, the level and detail of information provided by the intelligence troop expanded as well. In their spare time, the members of the intelligence troop trained SAF personnel to take over intelligence-gathering responsibilities.

### Psychological Operations

British PSYOPS experts developed a propaganda campaign designed to isolate the nationalist Dhofari insurgents from the communist “true believers” by emphasizing Sultan Qaboos’ civil development projects in Dhofar as well as the Marxists hostility to Islam. A printing press and broadcasting equipment from Britain allowed the Sultan’s information services to begin operation. Radio Dhofar broadcast news updates about the government’s plans and actions to the people of the province. To ensure that these broadcasts were received, subsidized transistor radios were put on sale in markets across Dhofar.<sup>63</sup> Guided by British advice, Radio Dhofar presented the news without spin or fabrication, in direct contrast to the insurgents’ exaggerated propaganda broadcasts which, over the course of the conflict, claimed to have killed three times the actual number of soldiers in the SAF.<sup>64</sup>

### Engineering

The SAF lacked combat engineers and the low state of education in the country meant that local skill in this area was unlikely to be forthcoming. Elements of the Royal Engineers provided invaluable support in Dhofar, assisting the execution of the Watts plan by drilling wells in the Salalah Plain and building schools and clinics in the major settlements.<sup>65</sup> The engineers also assisted military operations by building roads and constructing obstacles to hinder insurgent movement.

### Protection of RAF Salalah

With the Chinese and the Russians providing longer range mortars and Katyusha rockets to the PFLOAG, the joint RAF/SOAF base at Salalah became extremely vulnerable. In many cases, the insurgent mortar men were able to “shoot and

scoot” before the SAF could respond. The deployment of a Royal Artillery counter-battery team with advanced ground defense radar and an RAF mortar detachment with skilled spotters (collectively known as the “Cracker Battery”) provided an important defensive capability that the SAF could not easily supply. A squadron of security personnel from the RAF regiment was also deployed to provide perimeter security—freeing the SAF from an important static protection duty.<sup>66</sup>

### *Equipment*

As the SAF expanded and improved its force, Britain was the primary equipment supplier. Infantry weapons were upgraded from the old .303 Enfield to the semi-automatic *Fabrique Nationale* L1A1 rifle then in use by the British Army. The British General Purpose Machine Gun (GPMG) was also introduced to the SAF. With a range of 1800 meters and a more powerful 7.62mm bullet capable of penetrating the undergrowth on the Jebel, the GPMG became the workhorse of the Sultan’s army.

SAF equipment requests reflected practical needs: Night firing devices, artillery ammunition, armored cars, field radios, entrenching tools and so forth were all procured from British Army stores. When the British were unable to supply items sought by the Sultan, such as the Bell Augusta helicopters used by the SOAF, Foreign and Commonwealth Office personnel acted as intermediaries to approach third countries on the Sultan’s behalf.<sup>67</sup>

In equipping the SAF, the British used their influence to focus the Sultan on materials that were directly applicable to the counterinsurgency campaign being waged. They deliberately avoided steering the SAF toward “expensive and sophisticated equipment” and when necessary, the British were not afraid to tell their client “no.”<sup>68</sup> At one point, Sultan Qaboos asked the British to supply his Air Force with napalm because he felt that the fragmentation bombs then in use did not have a large enough blast radius. Concerned about the effect the use of napalm would have on uncommitted civilians on the Jebel as well as international public opinion, the Ministry of Defense and the Foreign Office rejected his request on the grounds that the political repercussions far outweighed the military benefit.<sup>69</sup>

### *No Free Lunch*

While the British provided a wide spectrum of direct and indirect support to the Sultan’s Armed Forces, there was one catch: All of it came with a price tag. Initially, the Sultan was charged for every bit of aid received, including equipment

provided from existing British Army stores. The RAF even charged the Sultan for cargo flights chartered to deliver materials to Oman.<sup>70</sup>

“Pay for Support” also extended to personnel. The Sultan was billed for all British servicemen deployed to Oman. In recognition of the important operational experience gained in Dhofar, for some units, such as the SAS and the Field Surgical Team, he was charged only for “extra costs,” the difference between maintaining the unit at its home base and its deployment in Oman. However, for the large majority of British personnel, including all of the seconded British officers, the Sultan paid the full cost of salaries and benefits. At one point, the cost of seconded officers alone approached \$9.9 million per year in today’s terms.

While the practice of charging a host nation for security assistance is not unheard of, at that time, unlike many of the emirates to the North, Oman was not an oil-rich country. In 1971, Oman’s gross domestic product was the modern equivalent of \$850 million. As the cost of prosecuting the conflict began to reach an unsustainable level of 50% of GDP, the SAF began objecting to the high cost of British support. Seeking to reduce the burden on its ally, the British provided a one-time grant of \$8.6 million worth of ammunition, equipment and SAS support.<sup>71</sup> Concerned that they were “pricing themselves out of the market,” in 1973, the British began subsidizing half of the cost of the seconded personnel in the Sultan’s service.<sup>72</sup>

### **Other Support**

Despite the expansion of the SAF, Oman still lacked enough ground troops for the operations required to defeat the insurgents. London had made it clear that the deployment of British combat troops was not an option, so Oman had to look elsewhere for help. Under the guidance of his British advisors, the new Sultan took steps to end Oman’s diplomatic isolation—joining the United Nations and the Arab League as well as establishing diplomatic relations with anti-communist regimes in the region such as Iran and Jordan.<sup>73</sup>

Diplomacy paid off as both Iran and Jordan provided troops to Oman. The Shah of Iran had no desire to see a revolutionary government controlling the other side of the Strait of Hormuz. To support Oman, in late 1973, he dispatched a battle group of 1,500 soldiers backed by fighter aircraft, helicopter troop carriers and artillery.<sup>74</sup> While this heavy force was not well-suited to small-unit counterinsurgency operations, it was very able to hold territory and to defend static positions. For its part, Jordan sent Oman several intelligence officers to bolster the SAF’s information gathering network, as well as combat engineers.<sup>75</sup>

## Defeating the Insurgents

With an expanded force, as well as material and diplomatic support from abroad, Sultan Qaboos was finally ready to reclaim the Jebel. With the RAF providing security to the airbase at Salalah and the newly formed guard units (the equivalent of 2 battalions) protecting secured areas, the expanded SAF was able to maintain two infantry battalions, as well as supporting artillery and armored car units, in Dhofar at any one time—a force equal in size to the entire pre-coup SAF.<sup>76</sup> These ground units were supported by a strike squadron configured for ground support and a helicopter squadron for enhanced mobility and resupply.<sup>77</sup>

Efforts to permanently clear the Jebel of insurgents followed a regular pattern. As a former commander of Dhofar headquarters describes:<sup>78</sup>

1. A SAF operation in strength supported by a Firqat secures a position of the Firqat's choice which dominated its tribal area.
2. Military engineers build a track to the position giving road access, followed by an airstrip if possible.
3. A drill is brought down the track [to bore a well for the local civilians] followed by a Civil Action Team [who set up a] shop, school, clinic and mosque.
4. SAF thins out to the minimum to provide security.
5. Water is pumped to the surface and into the distribution systems prepared by military engineers to offer storage points for humans, and troughs for animals.
6. Civilians come in from miles around and talk to the Firqat, SAF and Government representatives. They are told that enemy activity in this area will result in the water being cut off.
7. Civilians move out in surrounding areas and tell the enemy not to interfere with what is obviously 'a good thing.'
8. Enemy, very dependent on civilians, stops all aggressive action and either goes elsewhere or hides.
9. Tribal area is secure.
10. All SAF are withdrawn.

As the PFLOAG fighters were denied easy access to civilian support, they were forced to choose between fighting government forces simply to acquire enough provisions to sustain themselves, or breaking into smaller units that were less effective militarily.

At the same time, the SAF sought to cut off the insurgents' supply lines. All PFLOAG supplies were transported along a single route from their secure supply

base at Hauf in Yemen. Not only did clothing, ammunition and money flow into Dhofar along this way, but it was also the route used to evacuate wounded and move units back to a sanctuary for rest and retraining.<sup>79</sup>

With the assistance of combat engineers from the United Kingdom and Jordan, the SAF established a series of fortified lines consisting of obstacles, mines and barbed wire, similar to the *barrages* used by the French in Algeria.<sup>80</sup> Manned by SAF and Iranian troops, these fixed lines were designed to interdict the insurgents' supply route. As popular support for the PFLOAG lessened due to Firqat/CAT operations and the reduced flow of supplies weakened the insurgents, interdiction lines were built to box in the rebels from all directions. In the end, the only escape for the remnants of the PFLOAG and the PDRY troops who were supporting them was to flee under the cover of night, across the border into Yemen. On 11 Dec 1975, Sultan Qaboos announced that order had been restored in Dhofar.<sup>81</sup> Even with Sultan Qaboos reforms, a viable counterinsurgency strategy and allied support, it still required five years of fighting after he took power to bring the conflict to an end.

### **Assessment**

The successful campaign in Dhofar was one of only a few instances where an active Marxist insurgency was defeated by a Western-backed power during the Cold War. That fact alone makes the British support effort to Oman of interest to historians. However, there are a number of lessons to be drawn from this case about the organization and conduct of security assistance to counterinsurgency that have implications for future security cooperation efforts.

#### *Proper Vision*

**Ensuring that the host nation's plan of action is sound is one of the most important elements of supporting counterinsurgency.** Sultan Said did not have a viable strategy for defeating the PFLOAG: applying repression and military force to what was essentially a political problem. On the other hand, the British provided the Sultanate with a real strategy, in the form of the Watts plan, which was based on their years of experience in a number of "small wars." The counterinsurgency plan properly focused on the people of Dhofar and emphasized the roles that the government (including the SAF) could play in improving their lives.

The British also had a proper vision of their own role in the conflict. Aid and support was merely a stop gap measure until the Omanis could develop the capacity to handle the situation themselves. The training of Omani soldiers in technical

fields and the creation of career paths for native officers in the SAF are examples of implementing this vision.

#### *Consistency of Support*

**To be effective, support to a host nation must be consistent.** Once committed to assisting Oman, the government in London remained dedicated to that task as a national policy and cultivated the image that they were “there to stay.” Even after the Labour party came back to power in 1974, they continued the previous government’s policy of supporting Oman despite the fact that it may have antagonized segments of their left-leaning political base.

#### *Targeted Deployment of Skilled Personnel*

**Specialist personnel can provide an invaluable supplement to the armed forces of a developing nation.** The most significant assistance rendered by the British was the provision of experienced officers and technical support personnel. Given the widespread lack of education in Oman and the absence of professional military training, these capabilities could not be obtained domestically. British officers commanded the Sultan’s forces at all levels from company commander to supreme commander. The multi-unit combined-arms operations that characterized the second half of the campaign required the kind of training and operational experience that the British possessed. Dhofar has been called a “company commander’s war” and it remained the case throughout the conflict that, “the fighting capability of any sub unit is as good or bad as the standard of its British officer.”<sup>82</sup>

The technical support rendered by British personnel was also noteworthy. For example, the impact that the 14-man Field Surgical Unit had on SAF morale was disproportionate to its size. Similarly, the RAF pilots, ground defense radar teams, and Royal Engineers employed skills and equipment that were beyond the Omanis’ capabilities. Deployment of British specialists also had the important effect of freeing up SAF units for offensive action. For example, withdrawal of the “Cracker Battery” would have meant the withdrawal of all Omani artillery officers supporting operations in Dhofar in order to defend RAF Salalah, stripping SAF infantry of necessary fire support.<sup>83</sup>

The Special Air Service, with its experience in unconventional warfare, filled a niche that neither Omanis nor regular British soldiers could provide. Their ability to raise and lead the *firqat*, as well as the Civil Assistance Teams, was a prime reason that Sultan Qaboos was able to regain the upper hand from the PFLOAG.



The training that the SAS provided to the infantry regiments of the SAF was also important. Overcoming the morale-sapping “Jebelitis” required the kind of tough, realistic training only the SAS could provide. As British counterinsurgency practitioner Julian Paget notes,

No troops can operate efficiently in undeveloped country in small numbers without experience and the confidence that springs from it. Ultimately the will to master the terrain and the enemy is the decisive factor, which gives the infantryman his mobility in action. This precious quality can only be acquired by hard training; it cannot be issued like a piece of equipment.<sup>84</sup>

### *Secondment*

**Attaching officers directly to the host nation’s service provides an alternative to the “advisor model.”** The manner in which most British officers were deployed to Oman, not as advisors but as integral parts of the units they served, had several advantages. Rather than having to persuade the man with power to issue an order, they were empowered with executive authority. In carrying out their duties, they provided an example for Omani junior officers and NCOs on how to plan, conduct and sustain operations. Living and working with the Omanis on a daily basis allowed the British to develop a detailed understanding of their units’ capabilities and their requirements.

Making themselves part of the SAF’s force structure, and therefore ultimately under the Sultan’s command, sent a strong message to Omanis that the government in Muscat, not London, was calling the shots. Seconded officers took their duty to the Sultan quite seriously, and there are accounts of high-ranking seconded officers withholding information from London about impending operations, particularly those against Yemen, because the British government might have political objections to the proposed action.<sup>85</sup>

### *No Combat Troops*

**In a counterinsurgency, the armed forces of the host nation should bear the brunt of the fighting.** In providing personnel, the British kept that point in mind as they focused on supplying capabilities and expertise lacked by the Omanis. Despite the need for large numbers of combat troops, the British declined to provide regular soldiers for combat operations in Oman. This had two effects. First, it required Oman to provide its own soldiery, which it did by tripling the size of the SAF between 1970 and 1972. Second, when this proved insufficient, Oman reached out to regional allies. The deployment of combat troops from a Muslim

country like Iran was far more politically acceptable than British troops would have been. Tangible support from Jordan and Iran also helped deflect criticism, particular from the Soviets and the political left in Britain, that the British were engaged in a neo-colonial enterprise or that Oman was simply a puppet state.

### *Scale and Structure of Support*

**When providing assistance, particularly during an active conflict, it is important that the host nation is made to be as self-reliant as possible.** Careful planning should be undertaken to ensure that foreign support does not exceed the host nation's ability to absorb and employ it effectively. Despite complaints from SAF officers that the British should have supplied more aid, this case illustrates Robert Thompson's principle that "the less aid given and the more the threatened country is compelled to rely on its own resources, the more effective the results will be."<sup>86</sup> The goal is to assist the host nation in key areas, not make them dependent on external support.

While the diplomatic staff at the British embassy in Muscat and many officers in the Sultan's service objected to charging Oman for support, this approach had positive aspects. Equipment procurement was focused on very practical items. When the British did provide direct aid, it was in the form of grants of supplies and services rather than straight budget transfers. The logic behind the British approach is fairly straightforward. To paraphrase economists Milton and Rose Friedman, when you spend your own money on yourself, you are motivated to get what you *need most* at the best price. When you spend other people's money on yourself, you get what you *want most* but price doesn't matter. It wasn't until the tail end of the war, when oil prices were through the roof, that the Sultanate began to shop for expensive military toys such as top-of-the-line jet fighters and sophisticated air defense systems.<sup>87</sup>

### *Coordinated Support Effort*

**The supporting nation must speak with a single voice, be well coordinated with the host nation's decision makers, and avoid overshadowing the host nation's own efforts.** The British ambassador was the point man for the assistance effort in Oman. Daily meetings between the CSAF and the defense attaché, as well as weekly meetings between the ambassador and the CSAF, ensured that the British were well-acquainted with the campaign progress. Despite the fact that the CSAF briefed the British General Staff from time to time, all inter-governmental communications and official requests for aid flowed through the embassy in Muscat. This ensured that the British delivered a consistent message to the Omani

government, and that the country team was not bypassed by officials in London who could potentially send conflicting signals.

When an outside power supports a host nation against an insurgency, it is critical that the host government appear to be in charge, with the ally in a supporting role. As counterinsurgency practitioner Frank Kitson noted:

The way in which an ally's help is delivered is as important as the help itself...If there is the slightest indication of the ally taking the lead, the insurgents will have the opportunity to say that the government has betrayed the people to an outside power, and that they, the insurgents, are the only true representatives of the nation.<sup>88</sup>

The ambassador and his staff conscientiously took steps to project the public image that they were the supporting power. As former British Ambassador to Muscat Sir Donald Hawley recounts: "Frequent contact between Ambassador and CSAF was obviously vital. It was, however, neither appropriate nor necessary that we should meet too often at the Embassy or elsewhere."<sup>89</sup>

#### *Host Nation Structure for Coordinating Counterinsurgency*

**Without a structure to control and coordinate the host nation's civil and military efforts, no amount of aid or advice will achieve the desired result.** The reciprocal of the previous lesson is that the host nation government itself must be properly organized if the support effort is to be put to good use. In the case of counterinsurgency, this means an effective integration of the host nation's civil and military powers. Oman represents an extreme example as Sultan Qaboos' position as head of state and Commander-in-Chief, backed by his ability to rule by decree, created a level of unity between the civil and military aspects of the government's counterinsurgency campaign that is not likely to be found in other settings. Unlike his father, Qaboos did not interfere with military decision-making or use his position as Commander-in-Chief to the detriment of military efforts. The CSAF's position as commander of all land, sea and air forces in Oman allowed the military aspects of the counterinsurgency campaign to be carried out without the inter-service rivalries and bureaucratic conflicts that can be found in other militaries.

#### *Timing of Intervention*

**In planning to support a foreign counterinsurgency campaign, careful attention must be paid to the domestic political situation in the host nation.** A number of British officers serving the SAF, including a former CSAF, Major General Corran Purdon, have criticized the British government for failing to provide

timely aid to Sultan Said. As Purdon writes, “if they gave us what we asked for straight away—very little at the time—we could crush the rebellion. They had to support SAF with far more aid and consequent expense later. The old principle of ‘Firm and Timely Action’ had to be learned yet again at the expense, as always, of lives and limbs.”<sup>90</sup> Such sentiments are understandable, particularly when expressed by soldiers on the ground. However, as important as the British support was, it only succeeded because of a favorable change in Oman’s political environment. Without the accession of Sultan Qaboos and his approval of the reforms and civil development efforts that undercut the popular support for the PFLOAG, the war would likely have been lost. Enhanced aid and support to Sultan Said would only have prolonged a failing effort. There is no evidence that after 1970 he would have reversed course and spent the money for more troops or undertaken the political reforms necessary to defeat the insurgents. If anything, increased aid would have caused him to resist change all the more, while closely associating the British government with his autocratic rule.

Without downplaying the importance of the other lessons previously discussed, the most significant finding from this case is that while security assistance to a foreign counterinsurgency campaign can reinforce positive political efforts, it is not enough on its own to bring about a victory in an unfavorable political environment. An outside power must carefully assess the domestic political environment of an allied nation before committing to support counterinsurgency operations there. If there is little prospect for reform or political accommodation to accompany military action, a nation should be wary of undertaking an open-ended support mission. If the stakes are high enough to compel involvement despite the unfavorable political circumstances on the ground, the supporting power must make maximum effort to favorably alter the political situation. Assistance plans should be specifically structured to encourage reform or modify the host nation’s strategy.

## **Conclusion**

There are several elements that make the Dhofar Rebellion a unique case. First, the overall scope of the conflict was quite small, with brigade-size operations being the largest military formations employed. Unlike in Vietnam, where American troops had to fight a television war, operations in Oman were conducted outside the media’s glare as most foreign journalists were not permitted into the country. Finally, the sparse population of the Jebel allowed a greater freedom of action, with less concern for collateral damage than might be found in other settings.

Those caveats aside, the British experience in Dhofar demonstrates that a small number of Western officers and special forces trainers can lead an indig-

enous force to victory in a counterinsurgency. While this approach has a number of important pre-conditions for success, the most significant of which are the political developments in the host nation, it can be a way of achieving success in peripheral conflicts. As US national security strategies put increased emphasis on the training of foreign security forces to combat terrorists and insurgents, it would be wise for political and military leaders to pay attention to important lessons learned in Dhofar.<sup>91</sup>

## Endnotes

The author would like to thank the trustees of the Liddell Hart Center for Military Archives, King's College London, for permission to quote from the papers of Peter Thwaites and the Warden and Fellows of St. Antony's College, Oxford for permission to quote from the papers of John Graham.

- 1 Tony Jeapes, *SAS Secret War: Operation Storm in the Middle East* (London: Greenhill, 2005), 1.
- 2 Thomas R. Mockaitis, *British Counterinsurgency in the Post-Imperial Era, War, Armed Forces and Society* (Manchester: Manchester University Press, 1995), 88.
- 3 "The Sultan's Dhofar War," *The Economist*, March 8, 1975, 52.
- 4 Tony Geraghty, *Who Dares Wins: The Story of the SAS 1950-1992*, (London: Little, Brown and Company, 1992), 180.
- 5 Bard E. O'Neill, William R. Heaton, and Donald J. Alberts, *Insurgency in the Modern World* (Boulder, Colo.: Westview Press, 1980), 219.
- 6 John Akehurst, *We Won a War: The Campaign in Oman 1965-1975* (Wilton, Salisbury, Wiltshire: M. Russell, 1982), 6.
- 7 See John Pimlott, "The British Army: The Dhofar Campaign, 1970-1975," in *Armed Forces & Modern Counter-Insurgency*, ed. Ian F. W. Beckett and John Pimlott (London: Croom Helm, 1985), 27. and Address given by H.M. Sultan Qaboos bin Said on Radio Oman, Muscat, 23 April 1971, Graham Collection GB165-0327, Box 3/3, MECA.
- 8 See, Pimlott, "The British Army: The Dhofar Campaign, 1970-1975," 27 and Mockaitis, *British Counterinsurgency in the Post-Imperial Era*, 73.
- 9 "Muscat and Oman: Half Sovereign?" *The Economist*, October 18, 1969.
- 10 Peter Thwaites, "The Dhofar Campaign, 1967-70," *Sultan's Armed Forces Association Newsletter*, no. 38 (March 1989), 22.
- 11 A.D. Lewis, "The Story of the Sultan's Armed Forces 1964-67," *Sultan's Armed Forces Association Newsletter*, no. 37 (Feb. 1988), 35.
- 12 British troops across the border in Aden also broke up a DLF support network there that had been smuggling weapons into Oman. John McKeown, "Britain and Oman: The Dhofar War and Its Significance" (M.Phil dissertation, University of Cambridge, 1981), 32.
- 13 Akehurst, *We Won a War: The Campaign in Oman 1965-1975*, 156.
- 14 In 1971, the group again changed its name to the Popular Front for the Liberation of Oman and the Arabian Gulf.
- 15 O'Neill, Heaton, and Alberts, *Insurgency in the Modern World*, 217.
- 16 C.C. Maxwell, *Sultan's Armed Forces Association Newsletter*, no. 2 (April 1969), 3.
- 17 McKeown, "Britain and Oman: The Dhofar War and Its Significance," p. 36.
- 18 O'Neill, Heaton, and Alberts, *Insurgency in the Modern World*, 222-224.
- 19 Akehurst, *We Won a War: The Campaign in Oman 1965-1975*, 24-25.
- 20 J.D.C. Graham, "The Sultan's Armed Forces: March 1970 to September 1972, Part I March to July 1970," *Sultan's Armed Forces Association Newsletter*, no. 31 (June 1983), 53-54.

- 21 Lewis, "The Story of the Sultan's Armed Forces 1964-67," 28.
- 22 Sultan's Armed Forces Headquarters, Bait-al-Falaj, Muscat, "A Brief on Muscat and Oman," June 1965, Thwaites Collection GB 0099, Box 2/2, Liddell Hart Centre for Military Archives, King's College London (hereafter referred to as LHCMA.)
- 23 McKeown, "Britain and Oman: The Dhofar War and Its Significance," 52.
- 24 Headquarters, "A Brief on Muscat and Oman," For a discussion of HQ staff, see Corran Purdon, *List the Bugle: Reminiscences of an Irish Soldier* (Antrim: Greystone Books, 1993), 195.
- 25 Graham, "The Sultan's Armed Forces: March 1970 to September 1972, Part I March to July 1970," 52.
- 26 Headquarters, "A Brief on Muscat and Oman,"
- 27 Purdon, *List the Bugle: Reminiscences of an Irish Soldier*, 195.
- 28 Jeapes, *SAS Secret War: Operation Storm in the Middle East*, 65.
- 29 Graham, "The Sultan's Armed Forces: March 1970 to September 1972, Part I March to July 1970," 52 and Lewis, "The Story of the Sultan's Armed Forces 1964-67," 28.
- 30 Lewis, "The Story of the Sultan's Armed Forces 1964-67," 28.
- 31 Geraghty, *Who Dares Wins: The Story of the SAS 1950-1992*, 184.
- 32 McKeown, "Britain and Oman: The Dhofar War and Its Significance," 23.
- 33 Lewis, "The Story of the Sultan's Armed Forces 1964-67," 31.
- 34 Ranulph Fiennes, *Where Soldiers Fear to Tread* (London: Hodder and Stoughton, 1975), 61.
- 35 Sultan's Armed Forces Headquarters, Bait-al-Falaj, Muscat, "The Dhofar Lessons," Section 8, Some Misconceptions on Dhofar, 1972, Graham Collection GB165-0327, Box 2/2, MECA.
- 36 McKeown, "Britain and Oman: The Dhofar War and Its Significance," 46.
- 37 For examples of SAF tactics under Sultan Said see Geraghty, *Who Dares Wins: The Story of the SAS 1950-1992*, p. 182 or Thwaites, "The Dhofar Campaign, 1967-70," 7-8.
- 38 Lewis, "The Story of the Sultan's Armed Forces 1964-67," 32.
- 39 Thwaites, "The Dhofar Campaign, 1967-70," p. 75. Richard John's story is also mentioned in Fiennes, *Where Soldiers Fear to Tread*, 13.
- 40 Lewis, "The Story of the Sultan's Armed Forces 1964-67," 33.
- 41 Pimlott, "The British Army: The Dhofar Campaign, 1970-1975," 30.
- 42 SAF Report, "Dhofar Ops as of Jan 70," Thwaites Collection GB 0099, Box 1/2, LHCMA.
- 43 "The Salalah Coup," Graham Collection GB165-0327, Box 3/5, MECA.
- 44 Mockaitis, *British Counterinsurgency in the Post-Imperial Era*, 72. An article in *The Economist* from the period puts the number of British servicemen in Oman at 750 with "300 RAF and Royal Artillery regulars guarding the air base at Salalah, 160 officers seconded to the Sultan's armed forces, about 170 more on contract to the Sultan and about 100 men of the Special Air Service." "The Sultan's Dhofar War," 52.
- 45 Donald Hawley, "Recollections of Muscat, Part II," *The Journal of the Sultan's Armed Forces Association*, no. 43 (April 1994). Accessed on CD-Rom at MECA.
- 46 Hereford 22 SAS HQ, "An Outline Plan to Restore the Situation in Dhofar Using Special Air Service Regiment Troops," 6 April 1970, FCO 8/1437, National Archives of England, Wales and the United Kingdom (hereafter referred to as NAUK). For a further

discussion of the strategy of "Operation Storm" see Geraghty, *Who Dares Wins: The Story of the SAS 1950-1992*, 183-184. and Jeapes, *SAS Secret War: Operation Storm in the Middle East*, 31-33.

47 Peter De la Billiére, *Looking for Trouble: An Autobiography -- from the SAS to the Gulf* (London: HarperCollins, 1994), 269-270.

48 J.D.C. Graham, "The Sultan's Armed Forces: March 1970 to September 1972, Part II Autumn 1970 to Spring 1971," *Sultan's Armed Forces Association Newsletter*, no. 32 (December 1983), 50.

49 "SAF Training Regiment," *Sultan's Armed Forces Association Newsletter*, no. 9 (June 1972), 26.

50 *Ibid.*, 37.

51 *Ibid.*, 26.

52 Sultan's Armed Forces Training Regiment, "Framework for Omani Officers' Promotion Exams," 15 March 1972, Graham Collection GB165-0327, Box 1/4, MECA.

53 Graham, "The Sultan's Armed Forces: March 1970 to September 1972, Part II Autumn 1970 to Spring 1971," 50.

54 Jeapes, *SAS Secret War: Operation Storm in the Middle East*, 30-31 and Memo by A.A. Acland, "SAS in Dhofar," 1 February 1971, FCO 8/1688, NAUK.

55 Letter from Lieutenant Colonel W.M.L. Adler Foreign and Commonwealth Office to J.H.A. Thompson, Ministry of Defence, "SAF Build-Up," 8 July 1970, FCO 8/1437, NAUK.

56 Umm al Ghawarif Camp, "CSAF's Review of the Situation in the Sultanate, July 1971," 17 July 1971, Graham Collection GB165-0327, Box 3/6, MECA.

57 Jeapes, *SAS Secret War: Operation Storm in the Middle East*, 53-54.

58 Ranulph Fiennes, "Under a Foreign Flag," *The Daily Telegraph Magazine*, 23 April 1971, 32.

59 Akehurst, *We Won a War: The Campaign in Oman 1965-1975*, 37.

60 Acland, "SAS in Dhofar,"

61 Jeapes, *SAS Secret War: Operation Storm in the Middle East*, 36.

62 Graham, "The Sultan's Armed Forces: March 1970 to September 1972, Part II Autumn 1970 to Spring 1971," 51.

63 Jeapes, *SAS Secret War: Operation Storm in the Middle East*, 164.

64 McKeown, "Britain and Oman: The Dhofar War and Its Significance," 70.

65 Graham, "The Sultan's Armed Forces: March 1970 to September 1972, Part II Autumn 1970 to Spring 1971," 51.

66 Akehurst, *We Won a War: The Campaign in Oman 1965-1975*, 32.

67 Telegram no. 1 from Washington to Consulate General Muscat, "Helicopters for Muscat," 20 October 1969, FCO 8/1091, NAUK.

68 Defence Policy Staff, "United Kingdom Defense Activity in Oman During 1973, Appendix 1: Guidelines for UK Defence Activity in Oman," 31 October 1972, FCO 46/835, NAUK.

69 See the various communications between the Ministry of Defence, Foreign and Commonwealth Office and the Embassy in Muscat contained in FCO 8/1687, NAUK.

70 Letter from Mr. J.F. Rickard Ministry of Defence to Lieutenant Colonel W.M.L. Adler, Foreign and Commonwealth Office, 16 May 1969, FCO 8/1091, NAUK.



- 71 Letter from Tom Bridges Prime Minister's Office to Anthony Acland, Foreign and Commonwealth Office, 22 August 1972, FCO 8/1857, NAUK.
- 72 Note from F.A. Heaton Treasury to A.E. Davidson, Foreign and Commonwealth Office, "Military Assistance to Oman," 6 February 1973, NAUK.
- 73 Donald Hawley, "Recollections of Muscat, Part I," *The Journal of the Sultan's Armed Forces Association*, no. 42 (March 1993). Accessed on CD-Rom at MECA.
- 74 *New York Times* December 31, 1973
- 75 McKeown, "Britain and Oman: The Dhofar War and Its Significance," 70.
- 76 Akehurst, *We Won a War: The Campaign in Oman 1965-1975*, 33-34.
- 77 Headquarters, "The Dhofar Lessons," Section 7, Own Forces in Dhofar.
- 78 Akehurst, *We Won a War: The Campaign in Oman 1965-1975*, 63-64.
- 79 *Ibid.*, 28.
- 80 Jeapes, *SAS Secret War: Operation Storm in the Middle East*, 164.
- 81 *Ibid.*, 230.
- 82 Sultan's Armed Forces Headquarters, Bait-al-Falaj, Muscat, "Assessment of the Situation by Major General Tim Creasey Commander Sultan's Armed Force," 16 October 1972, FCO 46/835, NAUK.
- 83 *Ibid.*
- 84 Julian Paget, *Counter-Insurgency Campaigning* (London: Faber, 1967), 165.
- 85 Purdon, *List the Bugle: Reminiscences of an Irish Soldier*, 218.
- 86 Robert G. K. Thompson, *Defeating Communist Insurgency: Experiences from Malaya and Vietnam* (London: Chatto & Windus, 1966), 163.
- 87 See the discussions contained in "UK Arms Sales to Oman" FCO 8/2234, FCO 8/2235, and FCO 8/2236, NAUK.
- 88 Frank Kitson, *Low Intensity Operations: Subversion, Insurgency, Peace-Keeping* (London: Faber, 1971), 57.
- 89 Hawley, "Recollections of Muscat, Part I." Accessed on CD-Rom at MECA.
- 90 Purdon, *List the Bugle: Reminiscences of an Irish Soldier*, 276-277.
- 91 The *National Strategy for Victory in Iraq*, issued in November 2005, identifies the building of Iraqi security forces as a key step to defeating the insurgency there. The March 2006 *National Security Strategy of the United States of America* emphasizes the need to work with allies to develop capable indigenous security forces that can combat terrorist and insurgent threats.



## **The Role of Advisory Support in the Long War Against Terrorist Extremist Groups**

(Transcript of Presentation)

**Dr. Thomas G. Mahnken—The Johns Hopkins University**

Well, good morning. Thanks for having me. I'm going to be a little bit of a radical today and not use Power Point. So we'll see how that goes. Before I begin, the topic I'm going to address today is *The Role of Advisory Support in the Long War Against Terrorist Extremist Groups*. So it's a fairly forward looking topic, but before I begin, I want to reassure everybody that, although I'll be talking about the present and the future, I am, in fact, a card carrying historian. So you can all feel safe.

What I want to talk about is based upon a project I've been working on in recent months, looking at how the US can improve it's capacity to advise foreign militaries, based both on our historical experience, what we're currently doing in Iraq, Afghanistan, and the Philippines and elsewhere. Based upon the British and Australian experiences, and so forth. What I'd like to do with the time I have today, I think, in a way, is to maybe take up where the last presentation left off, which is to talk about the role of advisory support in the long war against terrorist extremist groups.

Both the national military strategic plan for the war on terrorism, and the 2006 Quadrennial Defense Review (QDR) describe an indirect strategy, or should I say sketch out an indirect strategy, to defeat extremist groups. One that gives advisory support an important role. Most prominently, advisory support is key to our effectiveness today in Iraq and Afghanistan, but obviously other less well publicized efforts are also important. Such as USEUCOMs Pan-Sahel Initiative, Combined Joint Task Force—Horn of Africa, and Operation ENDURING FREEDOM—Philippines.

What I want to do in the time that I have is to flesh out this vision of an indirect strategy and raise some questions for future research. So I'll do so by addressing five topics. First, I'll take a couple minutes to discuss the indirect strategy as presented in Department of Defense policy documents. I'll then ask three questions, specifically pertaining to advisory support. How may advisors be used as part of the indirect strategy? What tasks may advisors be called upon to perform? And then, who should be our advisors? Then I'll conclude with some recommendations and questions for further research.

So to begin, let's just talk for a couple of minutes about the so-called "indirect strategy." Both the national military strategic plan for the war on terrorism and the 2006 Quadrennial Defense Review outline an indirect strategy for the long war. Both argue that working indirectly with and through foreign partners will play a central role in achieving success against terrorist extremist groups. As the QDR puts it, and I quote, "Long duration, complex operations involving the US military, other government agencies, and international partners will be weighed simultaneously in multiple countries across the world, relying on a combination of direct, or visible, and indirect, or clandestine approaches. Maintaining a long term, low visibility presence in many areas of the world where US forces do not traditionally operate will be required. Building and leveraging partner capacity will also be an absolutely essential part of this approach, and the employment of surrogates will be a necessary method for achieving many goals. Working indirectly with and through others, and thereby denying popular support to the enemy, will help to transform the character of the conflict. In many cases, US partners will have greater knowledge and legitimacy with their own people and can therefore more effectively fight terrorist networks. Setting security conditions for the expansion of civil society and the rule of law is a related element of this approach."

So, the QDR, among other documents, envisions counterinsurgency on a global scale. And this indirect strategy has three main elements. First is the need to integrate all instruments of national power. In some cases, the role of the military will be to take the lead. More often, however, the role of the military will be to hold the line against extremists to buy other agencies the time they need to restructure the environment so as to make it much less hospitable to extremism.

Second, it requires that we work with and through partners, probably in dozens of countries simultaneously, to combat extremism at the global level, regionally, and then locally.

Third, in many cases, it will require that we maintain a small footprint. Now, that's not true in all cases. In some cases, we actually may want to have a very large and visible presence, but in many other cases, we're going to want to maintain a small footprint. Our posture should be designed to bolster the legitimacy of local governments and undercut Jihadist propaganda concerning American occupation. I believe that the indirect strategy is both the right thing to do, in other words, it's well suited to the conditions that we face, but it's also sustainable. I think it's the only sustainable strategy, politically, in the United States.

One of the tasks that the Defense Department is currently facing is how to implement the indirect strategy. So in the time I have, I want to move this ball down

the field a little bit by answering ... trying to answer three basic questions. How will advisors operate in implementing an indirect strategy? What will advisors do? And then, who should advisors be?

So to the first question, how? In other words, the role of advisors in the indirect strategy. Well, it's clearly a crucial role. The United States needs to work with friends and allies to help them counter extremism on their own soil. We also need to be able to conduct unconventional warfare in areas that are either ungoverned or hostile to the United States. So both to work with existing governments, and then also work with non-governmental groups as well. It is not an understatement to note that these men and these women, these advisors, will win the war for us. At least as far as the US Armed Forces are concerned. They will be at the forefront of this war.

Now, the most prominent current advisory efforts underway are obviously those in Iraq and Afghanistan, and I can't overstate the importance of those efforts. Building effective Iraqi security institutions is the lynch pin of success in Iraq. And in Afghanistan, helping the Afghan government extend its sovereignty across the country is crucial to its success as well. It would be wrong, however, to view either of these very important operations as the template for future advisory efforts, or even contemporary advisory efforts in other areas. There's certainly a lot that we can learn from our experience in Iraq and Afghanistan, but we shouldn't be planning the next campaign to be a repeat of either of these. Certainly we may again have to overthrow a hostile regime and build new security institutions, as we're doing in Iraq. We may again have to transition from what was essentially an unconventional warfare campaign to foreign internal defense, as we are doing in Afghanistan. Both are possibilities that we need to prepare for. But we are not going to win the long war by overthrowing one regime after another. Rather, we will do so by helping, often indirectly, local governments and non-government actors in their struggle with Islamic extremism. In other words, the pattern of future operations may resemble Iraq or Afghanistan less than our advisory efforts in the Philippines, our long term advisory efforts in Thailand, or even a number of the historical cases that we've heard about in this conference. In other words, we're likely to achieve success by establishing long term ties to key militaries in important regions.

What considerations should govern US advisory missions? First, US forces should be small, and should maintain a low profile. Second, they should be stationed abroad, perhaps for years, rather than months. Third, they must develop deep knowledge of the countries and societies that they are assisting. Fourth, and related, they should work with local forces, not supplant them. We would do well

to heed T. E. Lawrence's injunction ... I know this is one of General Petraeus' favorites, not to "try to do too much with our own hands." As Lawrence wrote, "Better the Arabs do it tolerably than you do it perfectly. It is their war and you are there to help them, not to win it for them." I think that's an important injunction for us to remember as well.

Another caveat is, you know, we're here at Fort Leavenworth. I'm here as a guest of the Army, and certainly much of this effort will involve ground forces. But the Navy and Air Force also have an important role to play in advisory support. A number of countries that are under threat are under threat, in part because they are unable to govern all of their sovereign territory. They lack access to great parts of their territory. Air advisory support and Naval advisory support can help address that. For that matter, the US Coast Guard has a role to play in advising foreign militaries, as well, and has a fairly capable, if small, advisory capability already.

So some of the questions that need to be answered, as we move forward and think about the how, is what level of presence do we need in various areas across the world? Second, where do we need persistent presence? Where do we need to be there all the time, and where do we need periodic presence? Third, a thing I touched on just a minute ago, what length of tour would be appropriate to both allow advisors to build and capitalize on local knowledge, but also give them the quality of life that they expect in a military career? Fourth, and something I'll come back to later, what role can US allies play? I think it is a key role.

Okay, second question. What types of tasks may advisors perform? We talk about security assistance, we talk about advisory support. I think, as many of us know, there's a lot that's subsumed under that label. First, US advisors will be called upon to perform a spectrum of tasks. We need to keep that spectrum of tasks in mind as we think about what our advisory capability needs to look like in the future. Now these tasks will range from training foreign troops in basic military skills, to training trainers, training foreign trainers, to advising foreign military units, to providing combat advisory support, to providing direct US military support, such as artillery fire support, intelligence, logistics, to foreign units. Each of these tasks, obviously, calls for different skills, different types of capabilities.

Second, each of these efforts will vary in scale from small security assistance missions that could be performed by a military training team, to direct combat by US Forces in support of local forces, as we see in Afghanistan. So we have a spectrum of tasks, we have differing scale, and then finally we have a variety of circumstances in which US advisors may be called to operate. In some cases, they'll be training and advising existing military units in an attempt to make them

more effective. Classic foreign internal defense, if you will. In other cases, they'll be working with surrogates or with auxiliary forces, classical unconventional warfare. And then in still other cases, they will need to create new military formations, as we are doing in Iraq and Afghanistan.

The key challenge that the Defense Department faces is how to reflect all of these variables, all these considerations, in force structure. In other words, how much of an advisory capability do you need, and where should it reside? The other important thing to note, too, is that much of what I have described is likely to be a steady state activity. There may be some contingencies. Again, I won't dismiss a future Iraq where you would need to rebuild security institutions from the ground up, but much of what I'm talking about is a steady state activity. It will be going on, continuously, across the globe. It will be the bread and butter mission for a good portion of the US military. There will certainly need to be a surge capability to deal with a large scale unconventional warfare campaign, or something like that, but much of what I've described will be the bread and butter mission of parts of the US Armed Forces.

Now of course, none of this is new. Much of what needs to be done involves rediscovering the lessons of the past and adapting them to current and future circumstances. In fact, I would argue that historically, this was seen as a bread and butter mission for large parts of the US military. For various reasons that we can talk about, it became, over decades, more of a peripheral mission. Bottom line is, it needs to come back to being a central mission for the US military.

Well then, this leads us to the third question, which is who should be advisors? Where should our advisors come from? Special Operations community, general purpose forces, allies, contractors? Well, different communities within the US military have important skills to bring to bear on the problem. But we also need to acknowledge the fact that each of these communities also has cultural barriers to this type of advisory work.

To cut to the chase, before I talk about the different communities and what they bring to bear, I think, if for no other reason than demand, and a substantial demand for advisory capability, our advisory force is likely to be made up of a mixture of Special Operations forces, general purpose forces, and allies. If one just adds up ... takes the best case and looks at a fully expanded Army Special Forces (SF) in line with the QDR, look at the number of training days that would be available. If that's all that SF did was train foreign militaries, and add in the Marine foreign military training units. And add in the Air Force's 6th Special Operations Squadron. Add in all the training days that are available with those units, it's still a fraction of what's

really needed to meet the demands to train and advise militaries in regions that we really care about. So demand will outstrip supply for the foreseeable future.

Let's talk about the various communities and what they bring to bear. First is Special Operations community, and most specifically Army Special Forces. The SF community is well suited to advisory support. Indeed, it is the only community in the US Armed Forces whose members are specifically selected and assessed based on their ability to work with foreign militaries. SF personnel are selected, at least in part, on cross-cultural communication skills, their training emphasizes advisory support, and advisory support is seen as central to their identity. But, as I've already said, first off, there are not now, and will not be in the foreseeable future, enough SF to go around. Moreover, there is a split within the Special Operations community, and also within the SF community more narrowly, between emphasis on unconventional warfare and foreign internal defense, and direct action.

Since 9/11, there has been a lot of emphasis on direct action, and at least according to a lot of the SF officers that I've interviewed as part of my research, there's at least a perception that the incentives for command, promotion and so forth, favor those on direct action missions over those doing unconventional warfare and foreign internal defense. Now of course, it's not a true dichotomy. You do foreign internal defense, you do unconventional warfare, to develop opportunities to strike bad guys, to do direct action missions. But still, this dichotomy is appearing and it's a concern in the SF community. Moreover, Operation ENDURING FREEDOM and Operation IRAQI FREEDOM have disturbed the traditional relationship between the numbered Special Forces groups and their regions. It's disturbed that historic pattern of building regional relationships. So clearly the SF community has a lot to bring to bear, but it's not enough. As I would put it, this is a task that's too important, too central to US strategy, to be given to a community with the adjective "Special" in its name. It needs to be a central role.

So what about general purpose forces? Historically, advisory support was a mission of general purpose forces, right? The vast majority of advisors in Vietnam were from the combat arms, the basic combat arms. That changed for a number of reasons. I think it changed, in part, because of the Cold War and the dominance of the central front. It certainly changed with the aftermath of Vietnam. And it definitely changed with the Nunn-Cohen Amendment and the establishment of US Special Operations Command, really gave that advisory mission over to Special Operations forces. And, I would say, allowed general purpose forces to move that mission over onto Special Operations forces.



As a result, today, aptitude and working with other cultures is not considered an important selection criteria in general purpose forces. There's little to no training in advisory support, although that is clearly changing for both the Army and the Marine Corps. And advisory support is seen as peripheral to the identity of general purpose units. That clearly needs to change, and it can change in a number of ways. Perhaps by establishing specialized units, new promotion paths, new career fields, and so forth. Something I'll come back to at the end.

The third community that we need to pay attention to when it comes to advisory support is allies. Many US friends and allies have great expertise in advisory support. We clearly just heard about the British in Oman, we know that canonical case of the British in Malaya and so forth. A number of our close allies know areas that we are concerned about quite well. Often they have long standing relationships with local forces. The British, in many of their former colonies. The French in Africa, the Australians in Southeast Asia. They've also developed interesting arrangements for advising foreign militaries, and we need to both learn from them, and work with them to share the burden.

Another way to think about who advisors should be, as not sort of organizationally, but in terms of the qualities of a good advisor. What are the personality traits? One of my hobby horses with the US military as a whole, the Defense Department as a whole, you could say the government as a whole, is we still do use kind of industrial age, industrial approaches to personnel management. We deny that we do it, but we more or less treat people as interchangeable parts in the machine. I think if the historical experience of advisory support teaches us anything, it teaches us that personality does matter. That individuals do matter. That certain qualities matter. And I think one of the reasons that SF does well in this area, is that it actually does select for a certain personality type.

What are the qualities of a good advisor? A good advisor should be culturally sensitive, competent in his or her Military Occupational Specialty (MOS), open minded, patient, humble, disciplined, self confident, capable of dealing with moral dilemmas, and tolerant of uncertainty. Not always personality traits that the military as a whole screens for. In some cases, not even personality traits that the military values above others. I know there's a tendency, I hear it quite often, to say, "Well, we need to find the next T. E. Lawrence." Which leads to several questions. One is, do you just go out and discover these people? Second, how many of them are there? Third, if you look at Lawrence's career, I don't know that you'd really want a lot of T. E. Lawrence's in the US military. He was a little bit of a discipline problem. But I think the better news, looking historically is, you don't need T. E. Lawrence.

History shows us that good officers, good, well rounded officers, can do advisory missions. My favorite example is John Pershing. If you look at Pershing's career, he began his career with the 6th Cavalry in New Mexico, leading a platoon, and later a company, of Sioux Indian scouts. What I would say is sort of the equivalent of advisory duty. Then commanding a company of the 10th Cavalry, the Buffalo Soldiers, at the Battle of San Juan Hill. Then assigned to the Philippines, where he earned the respect of the Moros. Then led the punitive expedition against Poncho Villa. Then, and only then, led the American expeditionary force in World War I. He really covered the full spectrum of operations in his career. But, I think beyond just his experience was his personality. As one of Pershing's biographers wrote, "Commanding a company of Sioux Indian Scouts was Pershing's first experience in handling men not of his own race or culture. He succeeded with them, just as he succeeded later with American Negroes and Philippine Moros, by treating them with respect and consideration. He did not tolerate them. He liked them." Those are the types of people that we need to find, we need to cultivate.

So what are my recommendations? I have a half dozen of them. The first, most basic one is that we need to think strategically about the mission of advisory support. We need to think of advisors as a strategic asset for the long war. They are—and to use the hideous jargon of the Pentagon—they are high demand, low density assets. Or, as Secretary Rumsfeld likes to say, more simply, stuff we don't have enough of. Or stuff we didn't buy enough of. Or, in the case of advisors, I think stuff we can't get enough of. So they need to be treated as a strategic asset. We need to think strategically about their employment. We need to manage advisory missions at the strategic level, at the joint level. And we need to deploy and maintain and assess advisory missions in consonance with a broader strategy for the long war. We, similarly, need to be able to measure partner capacity and success. We need to figure out how well we're assisting foreign militaries, when we need to scale back, when we need to ramp up, and so forth.

The next several recommendations have to do with the capabilities we need to implement this strategy. And I think it's useful to sort of think of it as a pyramid of capabilities. So second, I would argue that SF needs to get back to its roots. Its roots of unconventional warfare and foreign internal defense. The capacity of SF to conduct these missions needs to be preserved, needs to be enhanced. The fact is that there are other communities that can do direct action as well as SF, but there are no other communities that can do unconventional warfare and foreign internal defense as well. So SF needs to get back to its roots.

Third, and related to that, as soon as possible, we need to reestablish the regional orientation of Special Forces groups. The heavy use of Special Operations

forces in Iraq and Afghanistan has disrupted the traditional regional orientation of Special Operations commands. As soon as practical, we have to get that orientation reestablished. We need to get that dedicated, long term relationship reestablished.

But, as I said, Special Operations forces, Special Forces, are not going to be enough. So fourth, there's a need to establish a broader community of advisors. Here, I think there's room for innovation. I think what we're really looking for is something of a hybrid between a foreign area officer, an intelligence officer, a Special Forces officer, maybe with some engineering and Civil Affairs thrown in to boot. We may need to establish dedicated advisory units as well.

More generally, we need to do a better job of tapping into, first of all, the resources we already have in the US military, but more broadly, the resources that we have as a society. We have extraordinary resources in American society. We have citizens that speak every language in the world as their native tongue. We have people who can speak more eloquently about democracy, about freedom, than the highest paid Madison Avenue advertising executive. We need to get them involved. We need to get them mobilized as part of this effort. To do this, we need to have some sort of a selection process for advisors. Something that mirrors, if you will, the SF selection process, but is much more broadly based, to be able to get, not necessarily the best and the brightest, but the best suited to advisory missions, and get them in that career path.

Fifth, and this is something a lot of people have talked about, but it's worth repeating. We need a broad base of officers and noncommissioned officers with greater cultural knowledge and language skills. Again, we're under performing in tapping into our society's rich resources here. I think we need to think about this as a long term effort. Right now there's a tendency to view language and cultural knowledge as a training and education issue. In other words, we need to bring in adults and teach them foreign languages and teach them about other cultures. I think the services are doing about as good a job as they can, doing that with adults. But in fact, I think over the long term, it's not a training and education issue. It's a recruitment and retention issue. Language skill, cultural knowledge should be basic professional skills. Why not, for example, make four years of a foreign language mandatory for attendance at a military academy or an ROTC scholarship? God knows we make other requirements mandatory. There's no reason you couldn't make four years of a foreign language mandatory. Again, the skills that will be needed for us to succeed in this war are cultural, they're linguistic, they're people skills. We need to reward people for having those skills. I would say that having language skills is just as important as having jump skills or dive skills or things like that where you get special incentive pay. Maybe even more so.

And then this leads me to my final recommendation, my final point, which is that the services need to provide incentives for advisors. We need to establish career paths, command opportunities, so that those who are attracted to this field are taken care of, are promoted, and have a career. We need high level statements that advisory duty is the number one priority. Officers, justifiably, look at promotion rates and advisory duty needs to be rewarded with promotion. Similarly, and this is where I think the idea of dedicated advisory units comes into play, you need to have command opportunities as well.

So I've tried to sketch out a path to take the broad, kind of strategic guidance contained in the QDR and other documents, and move it down the field. And I would certainly welcome any questions and discussion and thoughts about how we would do that. Thank you very much.

## **Day 3, Panel 6 Question and Answers**

(Transcript of Presentation)

**Moderated by  
Mr. Matt Matthews—Combat Studies Institute**

### **Mr. Matt Matthews**

We'll go ahead and open it up for questions now. Yes, sir.

### **Audience Member**

Thank you, both of you. Excellent presentations. I have two questions for Mr. Ladwig. The first one is, to what extent did the British enlarge their footprint in Oman by seconding their British officers directly into the force structure rather than advisors? And the second, I just wonder if you could talk a little bit about civil assistance and how big a role it played. And whether the civil assistance applied had an effect on the evolution of Oman from a medieval state 30 years ago to what's a fairly modern state today.

### **Mr. Walter Ladwig**

Both very good questions. I don't necessarily believe that the visible footprint of the British officers was all that large. On the one hand, to take one segment, the support efforts, the deployment of the surgical teams and the engineers and units like that were based out of the RAF facility. So they largely remained in the compound. So there was an awareness the British were there and it was a joint facility, but it didn't really register or resonate with the larger populace that there were these masses of troops there. On the side of the officers themselves, now they certainly undertook efforts to sort of not emphasize their presence. They dressed in the same uniforms as the locals, they wore the same ... I have no Arabic, so I don't know ... the headdress, things like that. Also, when opportunities presented themselves, they went out of their way to minimize their visible presence. So, for example, when there were National Day parades or celebrations of successful operations, the only people you'd see marching in the parades were Omani soldiers, perhaps the sultan, and a few of the local officers. They lived with the units in the field, they really lived a bare bones existence. They did everything in their power to not draw attention to themselves.

As to the second question, I think absolutely these ... I didn't really get into them in this presentation, but these civil assistance teams which do have a lot in common with PRTs and similar organizations that were built around Special Forces personnel, I think the base was a unit of six that had one SAS officer, a teacher, a medic,

either civilian or military, a veterinarian, and then depending on the needs of the local area, perhaps an engineer or something like that. Absolutely kick started development in a number of places, and of course, as presentations before have indicated, became a major source of intelligence as the people got to know, saw the government was working in their favor, saw things were on their way. Now, that being said, in the case of Oman, what really helped a lot too was a.) the discovery of oil, and b.) the fact that in the late '70s, the price of oil shot through the roof, and suddenly pockets were lined and money could be poured into civil development. But in a lot of the remote places, I'd say that was an absolutely critical aspect.

#### **Audience Member**

This is for Dr. Mahnken. Sir, you've got your foot square in what my organization does for it's existence. In all respects, pretty much spot on. What you said was an excellent presentation. I think, though, in the short and the long term, the language skills are going to be the long pole on the tent. Fortunately, the good news is everything that you're talking about for the characteristics of an advisor, every single part of it is trainable. TRADOC is thinking really hard now on how they're going to do that, how they're going to train forces to train and to technically advise on the longer term. But I would say that one of our greatest problems in the recruitment side is going to be that the skills that you talked about are also important for the global business community, and we have to compete with them for those people. Every kid out there should be getting language, but what he thinks he should be getting it for is so that he can be a global business man.

#### **Dr. Thomas Mahnken**

I think you're right. And in particular when it comes to say, recruiting among the Arab American community. There are even greater challenges, which is that the first generation, second generation folks, the folks you'd really like, well, most of them are in the United States because they left their former country because they didn't like it. And most of those countries, the military is seen A., as not a very high prestige career field, and it's an instrument of oppression. So from everything I know, it's been extremely difficult ... I mean, I know we've made a lot of efforts, but it's been extremely difficult to recruit the Arab Americans for these types of things. It's difficult, but yes, the military needs to compete with private industry. Of course, we're not ... by relying so much on contractors on the battle field, we're also competing against ourselves, so it's even worse. Point well taken.

#### **Audience Member**

To get back to the seconded officer business, I find that interesting because that seems to be one of the instances where the lesson learned that you say was a posi-

tive thing for this particular, very small counterinsurgency, is directly opposite to most of the lessons that we've been talking about for the last couple of days, saying that we've got to let them do it themselves, we advise them, but let them lead. And yet, this seems to be an instance where it worked just the other way around. To what extent did the government, at the same time that this was going on, work out a way for leaders to, I don't know, to go side-by-side with them or establish leadership training schools so that this was just a temporary stop gap, just long enough to hold back the insurgency?

**Mr. Walter Ladwig**

Certainly. The British always had the view in mind of turning things over to the Omanis. But you have to recognize that they were starting at a pretty low level, given the lack of basic education, any professional military education, among most of the populace. So the advantage of this particular model was that they could rather quickly plug capability into the units. The fighting men themselves were quite competent, but there was no higher level military skill available in the sultan's forces. There was an establishment, as soon as the British involvement ramped up, of Officer Candidate School or basic officer training. The British did pay to send several Omanis to Sandhurst. I didn't get into the foreign relations, but Jordan took a number of officers. So there were attempts under way to develop these. The very small existing pool of Omani Lieutenants were provided with real on-the-job training programs to equip them with the skills they'd need to become Captains and Majors. How this particular case plays out, though, from sort of the enhanced British involvement to the end of the counterinsurgency is, at most, a period of about four years. So really, by the end of it, you just saw sort of the first Omani Majors starting to take an active involvement. However, once this conflict ended, the British continued to provide the assistance, and the Omani government continued to train to the point where the last British commander of the sultan's forces, I believe, was in the early 1980's. So there was absolutely a desire to turn this over. I mean, it wasn't just a belief that we'll lead them and they'll do the fighting. There was a desire to develop the capacity, it just simply did not exist. But I do take your point, that I'm a bit perplexed that it is sort of the outlaw in terms of the lesson that might be learned. But perhaps because of it's peripheral nature, being sort of a sideline conflict.

**Audience Member**

Desire and a plan. I mean there was, indeed, a plan.

**Mr. Walter Ladwig**

Yes. Yes, there was, indeed, a plan.

### **Audience Member**

I'd like to follow up with Dr. Mahnken on his point about the need to provide incentives for advisors. As you undoubtedly know, during the long involvement in Vietnam, we made strenuous efforts to do that type of thing, and I would say, with limited success. Being an advisor was, by far, the most difficult role in Vietnam. Most of the line officers, at least those in combat arms, if given a choice, would have preferred to serve in a US unit, probably because they saw that as a route to advancement. They also saw it as sort of the kind of thing they signed up for, and maybe more exciting and more heroic, and lots of other things that I know you know about. So what I'd like to ask you to do is comment on the possibility that you really can't incentivize a combat arms officer leaders to want to be advisors, and maybe we need a separate sort of parallel organization in which people with those kinds of aspirations, and I suggest, a significantly different set of skills, you mentioned people skills, for example, would be attracted to that and could move up that path and not have to compete with these other people. Would you comment on that?

### **Dr. Thomas Mahnken**

Yeah. That's an excellent point. I think you're right. It's something I should have developed when I was talking about this idea that you go look for Lawrence's. I mean, the best the military can do is try to attract people who are suited to this mission, and then give them a home, a path of advancement, and so forth. So that those people who are naturally attracted to this mission stay in. I think, essentially, that's sort of what you have with Foreign Area Officers. Well, somebody like Carl Eichenberry has done quite well for himself, but most Foreign Area Officers realize that they're not going to be Chief of Staff of the Army and so forth, but they have a good career path and they know they'll make it along. I think something similar in the advisory field might make a lot of sense. The danger, of course, is too much of a separation between classic combat arms and advisors. Simply because, you know, a lot of your legitimacy as an advisor derives from your skill in your MOS, that you're a skilled war fighter. So that clearly needs to be maintained as well. But yeah, I do think that there needs to be some new career areas, maybe some new organizations.

Of course, the difference, I would say, between now and Vietnam is that we don't have the central front. There was always the central front, as bad as the loss in Vietnam was, it was not as bad as a loss on the central front would have been. So, when Vietnam fell, you could always retreat to the central front. Well, there's no central front to retreat to today. So I think the advisory duty today, as compared ... well, it is comparatively more important, more central. So that should help. But I agree with your central contention, that basically what you need to do is create a congenial home to take care of the advisors.



## **A Historical Overview of Romanian Diplomacy and Great Power Security Assistance**

**Joseph M. Isenberg—Iowa State University**

### **Introduction**

American defense policy has undergone many radical changes since the end of the Cold War. American policy makers have, as a result, a host of new opportunities and challenges. Among the challenges, one difficulty of some significance is posed by the accession to NATO of a number of former Warsaw Pact countries. These states are possessed of their own history, diplomatic and strategic traditions and aspirations. Because the former Warsaw Pact countries were largely cut off from the West for at least fifty years, if not more, and because history in that period was largely viewed through an ideological lens, it is understandable if American policy makers are unfamiliar with the history of Southeastern Europe.

The purpose of our panel today is to examine one of the new NATO states, Romania, a recipient of considerable American security assistance, and to place its current foreign and defense policy in the context of pre-war history. We then hope to examine questions:

1. How can the Romanian-American alliance be explained, not in terms of immediate benefit to Romania, but in terms of traditional Romanian foreign and defense policy of long standing?
2. How have past Romanian governments dealt with alliances?
3. What is the cultural milieu that informs Romanian foreign relations with the West?
4. What are the implications of traditional Romanian foreign policy strategies for American policy makers, and what opportunities and hazards are created as a result for the United States?

It is the contention of the panelists that by careful consideration of previous Romanian alliances, and previous Great Power efforts at security assistance to Romania, a picture of Romanian objectives, consistent over time, will begin to emerge. The assertion that Romania has, over the last hundred and fifty or so years, operated with a consistent diplomatic strategy that has persisted through monarchies, authoritarian dictatorships, communist dictatorships, and which seems to have survived the 1989 Revolution may come as some surprise to American ana-

lysts. Nevertheless, careful consideration of the evidence and the possibilities implicit as a result of this conclusion may be of some value in formulating American policy towards Romania.

The Romanians have, in an effort, first to gain and then maintain independence since 1856, pursued a 'high-risk, high-payoff' strategy designed to achieve the creation, perpetuation, and restoration of the Romanian ethnic homeland. Because Romania was (and is) located in a dangerous and highly unstable part of the world, this has necessarily involved cooperation and alliance with the various Great Powers of Europe, and now, in 2006, with the United States. These alliances are not entered into frivolously, nor are they lightly discarded, though an aggrieved ally may indeed make such allegations. While in effect, the Romanian government has tended to execute its obligations scrupulously, though it may also attempt to drift away from one alliance in favor of another. When alliance obligations are kept, the Romanian government keeps its bargain even at the price of great national hardship. Indeed, in times of war, the Romanian government is willing to risk continued national independence on its obligation to the Great Power ally if there is some reasonable prospect of success.

At the same time, the Romanians can be counted on to enact three other policies, regardless of the wishes of the Great Power ally:

1. Romania has historically had its enemies or threats to its security, like Russia, the Ottoman Empire, Bulgaria, the Austrian Empire, Hungary, and today, Ukraine, right on the border. On the other hand, the Romanian preferred allies, Germany, France, Great Britain, and now the United States, have tended to be not only far away, but blocked from assisting Romania by a potential foe. Romania has thus tended to keep a large standing army of its own, disproportionate to the size and the resources of the country. The Romanians have historically viewed the military as one of the pillars of the state, and Romanian policy makers have usually tried to enhance their own military capability by bringing it as near as possible to the standard of the Great Power ally whenever possible. As an aside, it should be noted that the United States agreement to place bases on Romanian policy is a novelty for the Romanians, from a historic point of view. As a further aside, it will be seen that the Romanian effort at military upgrade has not always been an unqualified success, but is heavily dependent upon the resources available to the country.

The Romanian military has sometimes been placed at the disposal of the Great Power ally and has, when properly armed and supplied given a

good account of itself. The implications for American security assistance policy should be obvious.

The maintenance of a strong national defense, coupled with the guarantee of assistance from a Great Power or a combination of Great Powers to avoid trouble in the first place is what Mr. Florea describes as the Romanian 'double-security guarantee,' and will be further discussed in his paper. What is important to note for our purpose is that both prongs of the guarantee are important, perhaps equally important, to Romanian policy makers, the first being conventionally thought of as defense policy, and the second as foreign policy, though they are not so easily disentangled in this formulation.

2. The second aspect of diplomacy that Romanian policy makers can absolutely be counted upon to explore, sometime to the chagrin of allies, is multi-lateral in nature. The best way to prevent a threat to Romanian national state from developing is to keep peace generally. Therefore, the Romanian government, whether under the monarchy or under the Communists, laid great stress upon international organizations like the League of Nations and the United Nations. The Romanians were also great advocates of the Kellogg-Briand Peace Treaty movement between the World Wars, and developed an extensive diplomatic structure of their own designed to prevent revision of the Treaty of Versailles. Though it is beyond the scope of this paper, the Romanian leaders sought eagerly to forestall the invasion of Czechoslovakia in 1968, and approached the Americans to that end through the United Nations. Though they could do little for Czechoslovakia, they did manage to prevent whatever lay in store for them, which was the object of the exercise. The Romanians also worked to offer themselves as intermediaries between the United States and the People's Republic of China in the early 1970's, though they were ultimately ignored by the Chinese in favor of the Pakistanis. While this appeared to be an effort to reduce international tensions, none of this was probably looked upon with much favor by the Soviet Union, ostensibly Romania's ally and protector.

3. The Romanian government will properly fulfill its bargains, even if things go badly for the Great Power ally. However, the alliance serves the purpose of the defense and advancement of the Romanian government, not the other way around. Thus, Romanian governments have not hesitated to look around for different allies if it appears that there is a better fit available for Romanian policy.

Thus, the Romanian government abandoned the pro-German alliance in World War I, in favor of an alliance with France, Britain, and Russia. The

Romanian leadership of the period perceived the new alliance as better able to deliver at least some of the territorial demands of the Romanian state against German allies. The Romanians maintained an alliance with Nazi Germany in World War II, not out of any deep ideological conviction, but out of a determination to recover territory lost to the Soviet Union, Bulgaria, and Hungary at the start of the war. Throughout the war, the Romanians maintained some sort of diplomatic contact with the Allies, and, when it became apparent that the Germans would not advance Romanian interests any further, a switch was made, and the Romanian army fought with as much, or more, enthusiasm against the Hungarians as it did against the Soviets.

This paper will provide an introduction to Romania, and a brief survey of the diplomatic and military history of the country, and of security assistance efforts down to 1945. The oral presentation at conference will focus on security assistance in World War I, the inter war period, and World War II as a case study that provides examples of the tenets of Romanian diplomatic and security policy in operation, the Romanian behavior in the 1920's and 1930's and the response of Britain, France, Germany and the Soviet Union as a result being of particular interest. No pretense is made here to highly original scholarship, or to extensive consultation of primary sources, rather, given that Romania and Romanian history may not be highly familiar to an American audience, an overview is sufficient to provide a context for the work of the able Messrs. Florea and Hariton, and of Major Schumann to be fully understood.

### **Romanian Geography**

Romania is a country located in Southeastern Europe, on the Black Sea coast. Romania has an area of approximately 92,000 square miles. This is somewhat smaller than the State of Oregon, which has just over 97,000 square miles.

The population of Romania in 2006 is estimated at some 22 million people. Of these, 89.5% of the population are ethnic Romanians, 6.6% are Hungarians, 2.5% Rroma, which disparagingly used to be called 'Gypsies,' .3% are Ukrainians, .3% are Germans, .2% are Russians, and .2% are Turks. It should be borne in mind that the percentages of Hungarians and Germans used to be far larger, and this was viewed as a problem for Romanian policy makers in the period under consideration.

The vast bulk of the population are Orthodox Christians, the Hungarians, Germans and Rroma provide the basis for Roman Catholic and various Protestant denominations. Most of the Romanian Jewish population survived the war, and then

emigrated to Israel before the Revolution of 1989. Similarly, most of the German population emigrated to Germany after the end of World War II.<sup>1</sup>

Geographically, the country is bordered by Bulgaria in the south, Serbia in the west, Hungary in the north-west, Ukraine in the north and in the south-east, the Black Sea in the east, and the Republic of Moldova in the north-east. Rather confusingly, Romania contains a region called Moldova or Moldavia, and the Republic of Moldova is a region that used to be known as Bessarabia. In this paper, the region in modern day Romania will be called Moldavia, and the area that is the modern Republic of Moldova will be referred to consistently as Bessarabia.

Much of the countryside, especially in the southern part of the country, known as Wallachia, would look surprisingly familiar to an American visitor from the Midwest. The region has gently rolling countryside, and patchy woods, which gets more rugged as one approaches the mountains, and corn fields and small villages. The terrain, and the fields, would look very much in place in southern Iowa or northern Missouri. In Moldavia, the countryside is somewhat more rugged, and drier, and looks somewhat more like the eastern parts of Wyoming or western Nebraska, or some parts of the Dakotas. Running across the whole country, like a backwards letter 'L' are the Carpathians and the Transylvanian Alps, which separate Wallachia and Moldavia from the Transylvanian Basin and the Great Hungarian Plain to the northwest. The mountains form a considerable barrier to travel. Northwest of the mountains, the land again reverts to a rolling countryside.

The Romanians speak Romanian, a language derived from Latin, and so similar to Italian, Portuguese, French and Spanish. The preferred religion is Orthodox Christian, derived from the religion of the Byzantine Empire and Russia. Romanian culture has thus occasionally been torn between Western European and Eastern European ideas, and Romanian leaders have, as inclination and occasion suited them, posed as the eastern-most outpost of Western Civilization, as good Orthodox Christian rulers defending against a (usually Turkish) onslaught, or as the heirs of the Byzantine tradition, depending on circumstances.

### **Roots of Romanian History**

By the start of the nineteenth century, the bulk of the Romanian population lived in two quasi-independent principalities, which are usually named in English, Wallachia and Moldavia. These states were nominally subject to the Ottoman Empire. In addition, Romanian-speakers had migrated into immediately surrounding districts, both within the Ottoman Empire, and outside it, in the Austrian Empire. Within the two principalities, Romanians formed the vast majority of the popula-

tion. In the outlying districts, on the other hand, the Romanians lived among Serbs, Bulgarians, Hungarians and Germans.

Wallachia and Moldavia can be thought of only as quasi-independent, because while they had considerable local autonomy, they were ultimately dependent upon the Ottoman Empire for the conduct of foreign affairs and defense. The Turks collected an annual tribute, and also appointed a ruler for each principality, after 1711, these individuals were decidedly not of Romanian origin. Though this was a far from ideal situation for the Romanians, the Turks had refrained from incorporating the territory fully into their empire, and the ambiguous status of the principalities would eventually furnish the basis for independence and unification into the Romanian state.

Diplomacy figured prominently in Romanian efforts to gain independence from the Ottomans. The Romanian Principalities looked to Russia, Austria, Prussia, Britain and France for assistance in expanding their right of self-governance to national freedom. Since the Great Powers had their own interests in the Ottoman Empire, the Romanians were usually able to find some nation willing to meddle with the Turks for mutual benefit. The end of the Crimean War brought the Romanians in Wallachia and Moldavia the opportunity to select their own princes, rather than accept a Turkish appointment. In 1859, the Romanians in each principality selected the same individual, A. I. Cuza, to serve as Prince, and so achieved a sort of national union. They remained, however, subject to Turkish supervision.<sup>2</sup>

Because of internal dissent, the Romanians replaced Cuza in 1866 with a relative of the Prussian royal family, Karl of Hohenzollern-Sigmaringen, who took the regnal name of Carol I. Carol inclined to a pro-Prussian, and, after 1870, a pro-German policy.<sup>3</sup> A Bulgarian revolt in the territories south of the Romanian lands led to a Russo-Turkish war in 1877. The Romanians were confronted with the choice of remaining neutral, and attempting to have that neutrality confirmed and guaranteed by the Great Powers, as had been done with Belgium, or by actively participating in the war on the side of the Russians in an attempt to gain full independence.

The matter was debated in the Romanian Chamber of Deputies, and, in considering the declaration of war against the Ottomans, several opponents of the government wondered whether the Great Powers would protect the Romanians from reprisals in the event that the Russians lost the war, or did not come to the assistance of Romania. A member of the government, Dumitriu Bratianu, replied, “[t]his guarantee we must first seek among ourselves.”<sup>4</sup> This slogan summed up the government mood, and was used for some time by the governing Liberal Party

as a campaign slogan. Despite such bravado, however, the Romanians were forced to seek alliances which would help secure Romanian independence.

The Russians, initially, proved uncooperative, and declined the intervention of the Romanian army, hoping to win the campaign on their own, in order to forestall Romanian claims in any peace conference. The Romanians, for their part, were ill-prepared for war. The Romanian army at the outset of the war consisted of about 120,000 troops, of which fewer than half, or 58,000 could be deployed as a field army. Even the field army was badly equipped. Only about one-fourth of the troops possessed a serviceable rifle, and the government was obliged, half a year into the war, to launch a public charity drive to buy weapons for the army. Supplies and ammunition were also largely unavailable. Nevertheless, the Romanian contribution, though small, became decisive after the Russians began to suffer some setbacks in their campaign in Bulgaria, and required reinforcements. The appearance of the Romanian army, led by Prince Carol in person, enabled the Russians to defeat the Turks, and force the opening of negotiations.<sup>5</sup>

What the Romanians gained on the battlefield, however, they lost in the peace negotiations. Romanian independence was recognized, albeit grudgingly, by the main powers of Europe. However, several territories, most notably Bessarabia, were denied to the Romanians, and they thus had outstanding claims against their neighbors. The issue of Bessarabia, which was retained by Russia, would bedevil relations between the two countries to the end of World War II. Rectifying the borders of the Romanian state and building the Romanian nation would become a major preoccupation of Romanian leaders for the next seventy years.<sup>6</sup>

The Romanians concluded alliances with Germany and Austria. This was due partly to personal preference of the King, and partly due to perceived economic benefits received from German investment. Nationality issues, of the treatment of Romanians living in the Hungarian region of Transylvania, complicated these relations, and the Romanians began to drift away from the alliance with Germany and Austria-Hungary and towards an alliance with France and Britain as a result of the Second Balkan War, which the Romanians entered largely in order to relieve Bulgaria of some disputed border territory.<sup>7</sup>

### **Romania in the First World War and the French Military Mission**

At the outset of World War I, Romania was still nominally allied to Germany and Austria-Hungary. Public sympathy, and indeed the sympathies of most of the members of the government, lay very much with the British and French. The onset of the war made it plausible that Romania could incorporate some or all of the Ro-

manian-majority districts in Transylvania and Bukovina, and reopen the Bessarabian question in the event of an Allied victory.

Romania was, however, in no way prepared for war, and, given the difficult position of the monarchy, the only advocate of the German alliance, the Germans did not press the Romanians to honor the terms of their alliance, but preferred quiet neutrality. The position of the other Central Power, Italy, which also had territorial claims upon the lands of the House of Habsburg, proved dispositive for the Romanians, and, when the Italians declared neutrality, on the grounds that the Austrians had failed to consult them before delivery of the ultimatum to Serbia, the Romanians followed suit.<sup>8</sup>

There followed, from 1914 to 1916, a sort of bidding war, in which both the Central Powers and the Allies attempted to persuade Romania to agreement. The Germans and the Austrians could not hope to win this dispute, as the Allies could offer Romania territorial compensation from Transylvania and Bukovina, which the Germans could not hope to match. The process was accelerated by the death of Carol I in December, 1914, and the accession of his nephew, Ferdinand as King of Romania.

From the point of view of the Romanians, however, the mere offer of territory at the expense of Austria-Hungary was insufficient to induce them to enter the war. The Romanians also demanded, as a precondition of their entry:

1. A substantial amount of military equipment, including at least 300 tons of munitions per day from Russia and Italy;
2. A technical mission, ideally supplemented by a large number of British, French and Russian troops, and;
3. Simultaneous offensives in France, in Italy, and in Russia to relieve pressure from the Romanian front upon Romanian entry, together with either a Russian offensive against Bulgaria to be launched from Romania, or a British and French offensive against Bulgaria to be launched from Greece. The Romanians did not wish to enter the war, in other words, if the first benefit they would receive was the immediate and undivided attention of their enemies.

This proposal was resisted by the Russians, who did not believe that they could accommodate the Romanian military demands, and who did not wish to grant the Romanians any promises of territorial aggrandizement at the peace settlement, lest the issue of Bessarabia also be brought up. The way forward was shown by



the French, who persuaded the Russians that the military benefits outweighed the costs, and that the Romanians could be ignored if their demands proved too inconvenient at the final peace conference.<sup>9</sup>

The Romanians were thus promised most of what they requested, in exchange for Romanian entry into the war not later than August 28, 1916. The Romanian army that entered World War I was, if anything, less prepared than the one that had fought the Turks in 1877. The force had doubled in size, to 830,000 men, from the time of the Second Balkan War in 1913 to the time of Romanian entry into World War I. However, the purchase of weapons had not kept pace. Romanian divisions had half the number of artillery pieces and between one-third and one-fourth the number of machine guns as were found in the Austrian army, which was not necessarily well equipped compared to the Western Allies or the Germans. Romanian industry could provide only one rifle cartridge per man, and two shells per artillery piece, per day. Any other munitions, and most equipment, had to come from overseas. This meant, since the Bulgarians had cut the railway lines from Serbia to Romania the year before, any assistance to the Romanians had to come from Russia, either via Archangel or via Vladivostok, throughout 1916 and 1917. The Romanians had attempted to rectify this situation by purchasing weapons and munitions from France, beginning in March, 1915, but these were still largely unavailable when the Romanians entered the war. The matter was further complicated by the fact that the French insisted upon payment for the weapons, which would bedevil post-war Romanian attempts to rearm.<sup>10</sup>

In lieu of a sizeable contingent from the Western Allies, the Romanians received a small British air contingent, and a group of French military advisors, under General Henri Berthelot. Some Russian troops appeared alongside the Romanians, but it proved impossible to send any other Allied forces until November, 1918, when the collapse of the Central Powers allowed the British and the French the opportunity to advance from Salonika. The simultaneous offensives, at least, did go off in July, 1916, but were largely spent by the time the Romanians entered the war. The worst fears of the Romanians were thus realized—the Brusilov offensive, despite its initial promise, did not succeed in its objectives, but did draw a large number of Central Powers troops into the area. These troops were thus in the region, and largely unemployed when the Romanians began their offensive.

The Romanians divided their forces into two main armies, a larger one, of 420,000 troops, to undertake the invasion of Transylvania, under Constantine Prezan, and a smaller one, of 140,000 troops, to guard the Bulgarian front, ultimately under Alexander Averescu. The Romanians expected that their small army would

be joined by a substantial number of Russians, who would assist in a campaign against the Bulgarians.<sup>11</sup>

From the start, things began to go badly from the Romanians. The Romanian army in Transylvania found no determined resistance, but was unable to move quickly enough to exploit the situation, advancing only one or two miles per day. Thus, the Austrians were able to move troops from Galicia to counter the Romanian advance before it could become truly threatening to their position. The Romanians stopped altogether on September 8, with their main army in an indefensible position on the wrong side of the mountains.<sup>12</sup>

The halt was caused by unforeseen developments on the Bulgarian front, coupled with the intervention of the French military mission. The combined German-Bulgarian army had begun an offensive immediately upon German and Bulgarian entry into the war, and had made a couple of advances. The French, for their part, counseled the central government to launch a counter-attack. This was agreed despite the objections of Prezan. To prepare for this, the Romanians began shifting troops from Transylvania to their southern front, and, on September 19, launched the 'Flamindina' operation. This failed to gain any territory, and the weakened northern army was forced back into the mountains, where the Germans and Austrians simply pushed it out of its defensive positions through attrition by November, 1916. Once the mountain positions were lost, the Romanians were pushed eastward towards the Romanian-Russian border. As a result of the failed offensives, the retreat, and the French advice, the Romanians lost 250,000 men, 290,000 rifles, 250 machine guns, and 450 artillery pieces.<sup>13</sup>

The destruction of the Romanian army led to proposals to place them under the direct command of the French military mission and General Berthelot. Most Romanian officers opposed this, Prezan considering it to be highly insulting. While the idea was formally abandoned, something similar was carried out by distributing the members of the French mission as 'technical advisors' throughout the Romanian military. Thereafter, Prezan was appointed Chief of Staff of the Romanian army, and his former chief of staff, Ion Antonescu, was appointed as Chief of Operations for the army. In 1942, Antonescu would remind one of the leaders of the Liberal Party, which had been responsible for the French alliance, of the consequences of the French military mission:

[The French sent us] a military mission 'to teach us to make war,' which, it is true, they did teach us, but which also humiliated us daily from a lack of tact and from vainglory. Have you forgotten that alongside every Regimental Commander, every Divisional Commander, every Commander of an Army Corps, and of an Army, there were

several so-called 'technical advisors' who, in very many cases, were in serious and permanent conflict with dignified commandants and competent command staffs, because they would attempt to redefine their roles from advisor to chief. Many operational errors with very grave historical consequences — political and military — were committed before the arrival of Marshal Prezan to the head of the General Headquarters, due to the fact that General Iliescu, who had lost all of his authority because of his notorious incapacity and immorality, had forced the army and its commanders to execute without question the orders and the requests formulated by General Berthelot, many times while beating his fist on the table....[The Romanian army] was placed — in reality even if informally — under the illegal command, illegal and humiliating for a people and its history, of a general who may have been — and was — very capable, but who had not a single responsibility before our history. He sought at any price, and rightly so, the salvation of the French front, even if that required the total sacrifice of all of France's allies. The necessity to relieve the Verdun, entailed the sacrifice, in many instances useless, of our soldiers on the crest of the Carpathians and in the unequal combat of Jiu and Cerna. I remind you, Mr. Bratianu, that on the arrival of Marshal Prezan and myself to the General Headquarters in December, 1916, we found French 'technicians' installed in all of the bureaus and sections of that institution of military leadership who, although the majority were lower in grade than their responsible Romanian chiefs, were invested, with the agreement of your brother [the Prime Minister] and on the order of General Iliescu, with discretionary leadership powers. It was the greatest humiliation that could be imposed on an army, even on a beaten one. Because of this, the moral depression provoked by the great and shameful defeats suffered up to then was aggravated while the activity of the General Staff was, in some compartments, paralyzed, because not all 'advisors' were fully competent, and not all [Romanian] chiefs of sections and services were without expertise. The superior military leadership, incompetent and without prestige, placed them in a position where it was impossible to evaluate their qualities. There was a great battle between Marshal Prezan and General Berthelot, in order to convince Berthelot to agree to confine the technical advisors to their advisory roles, and an even greater one, waged by me, in order to rid the bureau of operations, whose chief I had been named, of the French Colonel who I had found installed at my desk. Due to this dignified attitude, the bureau of operations was the only one which, throughout the entire period of the campaigns, did not have a technical advisor, because it did not agree to accept one, not because of personal vain-glory, but from a sense of national pride.<sup>14</sup>

This experience would ultimately color Antonescu's attitude towards foreign assistance while he was the dictator of Romania from 1940 to 1944, and the role of the German mission in World War II was thus very different from the role of the French one in World War I.

Despite adversity, and a certain amount of inter-allied hostilities, the Romanians and the French military mission managed to organize and train a second army of about a half-million men, for which the Romanians ordered equipment. This army won some victories, planned by Antonescu, in 1917, while the Romanian government weighed its options. The onset of the Soviet Revolution, in November, 1917, temporarily closed off any hope for continued Romanian participation in the war. The Central Powers, able to move forward across the Russian front at will, were able to surround any Romanian position in Moldavia and Bessarabia at their convenience. The Germans thus demanded the immediate surrender of the Romanian government, with the implied threat that Romanian independence would be extinguished if surrender were not forthcoming. Despite this danger, the King of Romania found it difficult to find politicians willing to accept the German terms. Therefore, it was not until December 9, 1917, that the Romanians entered into an armistice with the Germans and Austrians, and not until May 7, 1918, that a peace treaty was signed. Though the terms of the treaty were harsh, the Germans did concede to the Romanians the right to administer Bessarabia. The Romanians were expected to disband the army that they had carefully built up after 1916, but, through delay, the Romanian General Staff was able to hinder the disarmament to some extent, and preserve a force as a nucleus for future operations.<sup>15</sup>

Upon the collapse of the Central Powers in October and November, 1918, the Romanians reentered the war on the side of the Allies, formally re-declaring war on November 10, 1918. The German and Austrian armies were already withdrawing towards Transylvania, and the Romanians, accompanied by a French army from Salonika, followed them even after the conclusion of the Armistice, to begin the occupation of Transylvania and Bukovina. Romanian populations in those territories, and in Bessarabia declared for union with Romania, and this formulation was accepted by the Paris Peace Conference.<sup>16</sup>

The Romanians had thus managed to survive the war, with or perhaps despite French help. They had managed to re-enter the war in time to obtain the great object of Romanian policy, the creation of Greater Romania, with almost all of their territorial aspirations fulfilled. On the whole, the nation had a bad war, but a reasonably successful peace, unlike most of the other participants in the conflict. The nation that emerged was no longer ethnically homogeneous but had substantial German and Hungarian minorities in the territory acquired from the House of

Habsburg. Those minorities, and the Romanian government, could reasonably expect some effort at revenge from the defeated Central Powers, Germany, Austria, Bulgaria, and Hungary, which might lead to a revision of the settlement. In addition, chaos in Russia, now the Soviet Union, could not be expected to go on forever, and the Soviets might, as soon as their own affairs were in order, be expected to revisit the issue of Romania's eastern border. Time and the success of the peace settlement might be expected to solve most of these problems, to the extent that the Romanians were able to build either a just state, able to claim the loyalty of its residents, or one that assimilated the minorities, or both. That would be a problem of Romanian domestic policy.<sup>17</sup> To buy the necessary time for the government to accomplish its goals, on the other hand, was a problem for diplomacy and defense. In the event, of course, the Romanians would fail, just as the post-war settlement failed generally.

### **Romanian Defense and Diplomacy in the Inter-War Period, and its Failures**

The Romanian government, having achieved its war aims, had a vested interest in the maintenance of the status quo created by the Versailles peace settlement, perhaps more so than any other nation, including France. On the other hand, many of the tools necessary for the Romanians to maintain the status quo were deficient, or lacking altogether. The Romanian military, perceived as central to the maintenance of the Romanian state, had been nearly destroyed in the fighting, and needed extensive re-equipment and re-organization. The Romanians had failed to gain much from the reparations scheme created at the end of the war. The collapse of the payment system in the 1920's deprived the government of whatever hope it had of revenue from that source, and the financial situation of the government was exacerbated by the onset of the Great Depression in the 1930's. The Romanians were thus forced to rely upon extensive improvisation in both defense and foreign policy in an effort to serve the domestic requirement for stability.

The difficulty of supply during World War I led the Romanians to attempt greater self-sufficiency in arms production. In 1925, the Romanian government created a series of factories for national defense, to supply the army with small arms, munitions, and artillery. This was carried out with the assistance of the British firm, Vickers. At the same time, the Romanians created three aviation factories, in an attempt to build a local airpower. SET was founded in 1923, IAR in 1925, and ICAR in 1932. A stamp tax was instituted to raise money for aircraft purchases, though this was of limited value due to corruption, and due to the modest technical base with which the Romanians started. The Romanians both designed their own aircraft, and licensed French designs.<sup>18</sup>

The difficult financial position of the country prevented much headway in this effort. Romania spent less on defense than any other country in Europe; Germany and Hungary, allegedly disarmed, spent seven and five times as much, respectively, as the Romanians.<sup>19</sup> At the same time, the Romanians were required to pay for munitions ordered before or during the war, and either expended, lost, or only now arriving from France. The Romanian effort at building factories would prove of eventual, but not immediate, use in rearming the country, and the aviation plants were especially expensive. The factories and the obsolete French weapons previously ordered would, between them, absorb about 95% of the Romanian expenditures for weapons between 1920 and 1930, and IAR would, alone, take up half of that.<sup>20</sup>

Quality suffered as a result, as the troops were badly supplied with inadequate amounts of obsolete weaponry. One officer, Lieutenant Colonel Ioan Cernoianu described the state of the Romanian military as “a painful situation, which although extremely difficult to become accustomed to, nonetheless remains brutally real.” By 1932, one British observer called in to review the state of the Romanian military discovered that for rifle practice for the infantry, only three rounds per soldier were available in one unit examined, and that these were not even expected to be fired.<sup>21</sup>

In the cavalry units, a joke began making the rounds in which a cavalry officer lamented to the Minister of Finance, “I have told my men to pillage the countryside. I have told my officers to charm wealthy widows. But what do I tell my horses?”<sup>22</sup> The answer of the Quartermaster’s Department, implemented in 1933, was to advise military units to seek as much agricultural work as possible, as sharecroppers for local peasants, in order to provide fodder for the horses.<sup>23</sup>

One logical alternative, given that Romania was at the time the sixth largest producer of oil in the world, would have been to accelerate motorization of the army, and retire the horses, and fodder, in favor of tractors, trucks, and tanks. Though this was advocated by some officers, beginning in 1920, and though Antonescu created a small motorized unit in 1934 while Chief of the General Staff, motorization of the army was never seriously pursued as being too expensive and beyond Romania’s limited manufacturing capacity. As late as 1938, Romania possessed only about 35,000 motor vehicles of all sorts. The only manufacturing capacity in the country consisted of a Ford plant, capable of delivering between six and ten specimens per day, so long as the supply of imported parts could be maintained, and a factory established in 1937 specifically to produce 300 Renault gun chenillettes under license from the French.<sup>24</sup>

Since it was clear to the most casual observer that the Romanian army was in no state to defend the Kingdom, great efforts were made to enhance Romanian security through diplomacy. The architect of the interwar diplomatic strategy was the Romanian Foreign Minister, Nicolae Titulescu. Titulescu formulated five basic strategies for Romanian foreign policy; these would be followed until he was dismissed by King Carol II and not reappointed in 1936.

1. Romania needed to maintain good relations with all of the Great Powers in Europe, but especially with the victorious Allied powers likely to support the Romanian status quo and the Versailles Treaty.
2. Romania needed to create alliances with small states similarly situated and so likely from self interest to support the status quo in southeastern Europe.
3. Romania needed to forestall the Soviet threat to Bessarabia by creating relationships with small states also threatened by the Soviet Union.
4. Romania needed to convert the Soviet Union from a threat into an asset by maintaining good relations with the Soviet Union, and by encouraging the other neighbors of the Soviet Union to maintain good relations.
5. Romania needed to encourage collective security efforts and collective security organizations like the League of Nations in order to create an international legal framework to support the Versailles system wherever possible. The maintenance of peace generally in the world would thus support Romanian interests by preventing conflict. Since the failure of the first four points rendered this point irrelevant by 1939, if not before, it will not be further commented on in this paper.

The first and second of these points aimed at keeping the peace between Romania and the less important defeated Central Powers, viz., Austria, Hungary, and Bulgaria. This would secure Transylvania, Bukovina, and Dobrugea for Romania. The first point also hoped to secure Germany, if not as a friend for Romania, at least as a state unwilling to upset the balance in Europe. The third and fourth points aimed at keeping peace with the Soviet Union and at drawing the Soviets back into the European security system, as though they were the Russians that had been one of the Allied powers in World War I. The fifth point, as has been noted, was simply a catch-all, in case any conflicts broke out that might challenge security.

Great Power relations proved difficult for Romania in the 1920's and 1930's. of the various Allies, the United States quickly reverted to its traditional policy of disengagement from European affairs. Britain, having already settled Mediterranean and Near Eastern affairs to its liking, also paid the region little attention. Italy failed to accomplish its war aims on the battlefield, and left the peace conferences with little to show except a sense of grievance at having been ignored by Britain and France. Since the post-war settlement was of little benefit to Italy, it was scarcely likely to exert any effort to preserve the status quo, and, of course, would ultimately make common cause with the Germans in efforts at revision in the 1930's. Italy was thus fundamentally adverse to the Romanian conception of the post-war world as laid out by Titulescu. France, therefore, served as the only available Great Power prop for Romanian security in the aftermath of World War I.<sup>25</sup>

This suited the predilections of the Romanian elite perfectly well. Many Romanian leaders had, like Titulescu, been educated in France. France had also been the beneficiary of the confiscation of German investments taken at the end of World War I. The difficulty with this aspect of Romanian security arrangements was that French power and French prestige would decline throughout the 1930's, as German power rose and the French did little to counteract them.<sup>26</sup>

Trust in France was further diminished in 1934, when the French were requested to examine the state of the Romanian military and make recommendations. The Romanians coupled this request with a further request for equipment sufficient to arm ten divisions, to be paid for, if at all, over the next decade.

The French sent General Victor Petin, who had been chief of staff for Berthelot's military mission in World War I. Petin recommended that the French accede to the Romanian request. He was supported in his views by the French military attaché to Bucharest, Colonel Delmas. Despite the view of the local French delegation, French politicians hesitated. The French had their own military needs, and budgetary problems. The French government was thus not in a position to supply much military equipment, and not particularly interested in generous financing terms. An agreement was reached only in June, 1934. The French solved the payment problem by agreeing to send some surplus military equipment to be stored in Romania. This equipment would remain the property of French government, but the Romanians could use it if they wished. Lunga's analysis of the situation seems apt: "[t]his was an odd way of delivering for nothing a small amount of obsolete weapons, which did little to solve the Romanian army's plight."<sup>27</sup>

Even this was held up when the Romanians attempted to bypass French advice on the reconditioning of obsolete munitions. This recommendation became caught



up in a Romanian domestic power struggle between the Minister of National Defense, the Minister for Armaments, the King, and the Chief of Staff of the Army, Ion Antonescu, never a repository for patience in the face of incompetence, indolence and corruption. Antonescu touched off the controversy by wondering, in a memorandum, when this work would begin. He noted that the French, impatient at the delay, were threatening to withhold any further military aid until the required program was undertaken. The matter was only partly resolved by the resignation of the Minister of National Defense and his temporary replacement, ex officio, by the Prime Minister. Antonescu was then able to begin the program, with the connivance of the Prime Minister, in the confusion. The French were not particularly amused by the spectacle.<sup>28</sup>

Romanian attempts to procure French military equipment continued into the late 1930's. French deliveries were slowed partly by French military needs, and partly by labor unrest. In spring, 1938, for example, the Romanians expected the first installment of an order for 300 anti-aircraft guns, and 10 aircraft. The French delivered exactly none of this order, and the Romanians hinted that they might be forced to look elsewhere. The German Minister to Romania, Wilhelm Fabricius, immediately advised King Carol II that the Germans would be more than happy to supply anti-aircraft guns for oil. While the Germans did not immediately supplant the French as the arms dealer of choice for the Romanians, they did discover one of the means by which they could detach Romania from its pro-French alliance.<sup>29</sup>

The second security prop for Romania consisted of coming to terms with like-minded states. Two nations in, essentially, an identical position to Romania strategically were Yugoslavia and Czechoslovakia. Both had gained territory at the expense of Austria, Hungary or Bulgaria, and had every reason to fear the resurgence of any of these states. The Romanians therefore quickly concluded a series of bilateral agreements with the Czechs and the Yugoslavs, and the Czechs and Yugoslavs entered into agreement with each other in 1920 and 1921. This came to be known as the 'Little Entente.'<sup>30</sup> In September, 1933, Titulescu expanded the Little Entente to include Turkey and Greece in the so-called 'Balkan Entente.' The Turks and the Greeks were more amenable to working with the Romanians and the Yugoslavs than with the Bulgarians. As a result, Bulgaria was effectively isolated diplomatically from all of its neighbors, who were now linked in a common alliance to secure their borders. Any chance of a Bulgarian effort to redefine the Bulgarian-Romanian border was effectively negated when the Balkan Pact of February 4, 1934, between Yugoslavia, Romania, Greece, and Turkey was signed, guaranteeing the existing borders. This allowed the Romanian army to redeploy and withdraw from further defense of the Bulgarian frontier.<sup>31</sup>

Titulescu then sought to link these two pillars of Romanian security, by encouraging French ties to the Little Entente/Balkan Entente organization. The Little Entente states tended to support French initiatives in the League of Nations, and so were guaranteed French support, in the League and elsewhere, when the issue of revision of the Treaty of Versailles or the other treaties came up. Romanian attempts to formalize this mechanism, by introducing French security guarantees later in the 1930's, failed. The French declined to fully guarantee the Little Entente against a resurgent Germany without first being assured of British and Italian support, which, of course, was never forthcoming.

The crises of French-Little Entente-Romanian relations were the German occupation of the Rhineland, and the Czechoslovak crisis. The Little Entente powers were, in the first instance, ready to support the French against the Germans over the occupation of the Rhineland. When French objections failed to materialize, the suspicion was introduced that the French might not support the Little Entente against the Germans. The Czech crisis, of course, proved the suspicion to be correct. The Czechs were, as a result, removed from the alliance equation, and the remaining members, including Romania were forced to reevaluate their positions. The Romanians, seeing French indecision coupled with French inability to supply weapons, elected to begin searching for a better Great Power security guarantor.<sup>32</sup>

At the same time the Romanians worked to secure their southern and western frontiers, the Romanians worked on the problem of security against the Soviet Union in an effort to secure the eastern frontier. The Romanians began with an alliance with Poland in March, 1921. Romania sought to link this alliance with the Little Entente arrangement, but the Poles had no particular quarrel with the Hungarians, and did not wish to create one by entering into a defensive alliance against them. The Yugoslavs, Czechs, Greeks and Turks, in contrast, had absolutely no desire to begin an arrangement aimed at the Soviet Union, and refused to guarantee the Polish-Romanian arrangement. Thus, the Polish-Romanian agreement was aimed strictly at the Soviet Union, and constituted the core of a second Romanian alliance system.<sup>33</sup>

Titulescu also attempted to improve Romanian-Soviet relations, and embarked on a project to improve French-Soviet relations, by pulling the two nations into an alliance with each other and with the Little Entente. Progress was slowed on this by the Soviet claim to Bessarabia, until the Soviets were brought round to the idea of letting the question lie dormant for the foreseeable future. The Soviets accepted this because the Little Entente appeared to them to be a useful buffer against a resurgent Germany.<sup>34</sup>

In 1936, the German threat was sufficiently developed that Titulescu was able to persuade the Soviets to enter into negotiations with the Romanians and the French for a mutual defense pact. Many details were quickly settled, however, the principal disagreement focused on the role the French would take in the new security guarantee. The negotiators parted, and agreed to meet later in the year. Before this could happen, however, Titulescu was dismissed by King Carol II. The Soviets regarded the dismissal of Titulescu as marking a fundamental change in Romanian foreign policy, not favorable to their interests, and did not resume negotiations. In this they were probably correct, for the King drifted into an increasingly pro-German policy and the arrangements made by Titulescu increasingly broke down under the strain. Nevertheless, an opportunity was lost as a result.<sup>35</sup>

Without going into an extensive discussion of Romanian domestic political history, it will suffice to say for our purposes that Carol II, King of Romania from 1930 to 1940 distrusted democracy, and wished to institute at least an authoritarian rule under his personal dictatorship, and perhaps a fascist dictatorship centered under his leadership. In this, he labored under several disadvantages, both political and personal. The Romanian political system, while hardly ideal, had been established for nearly sixty years by this time, and functioned in a certain, predictable way. In order to suborn it, therefore, Carol II first had to completely destabilize it. This would be bad enough for domestic policy, but for a foreign and defense policy of the sort arranged by Titulescu, it would be catastrophic. A second political disadvantage was that Romania already had a fascist party, not under the King's leadership. In order to achieve his aims, Carol II would have either to assume leadership of the existing organization, or create a new one of his own. This brings up immediately of the personal disadvantages the King labored under. He was, no doubt, highly dishonest, and completely devoid of charisma. While the first of these might be no great disadvantage for a would-be fascist dictator, the second certainly was. He was also somewhat unstable, and, before 1930, had renounced or abdicated his rights to the throne on no fewer than five separate occasions, mostly over issues of his marriage.<sup>36</sup> The Romanian fascists, the Legion of the Archangel Michael, also known as the Iron Guard, refused to have anything to do with him, and he responded by killing or imprisoning as many members as he could lay hands on. On the other hand, most of the established politicians were unacceptable to Carol II for one reason or another, and so they were supplanted by personal friends of the King, most of whom were either corrupt or incompetent or both.

Carol II was certainly able to reduce the foreign and defense policy of Romania to absolute chaos. In an effort to fill the void, however, he attempted to turn to Germany. Efforts were focused on persuading the Germans to guarantee the Hungarian and Bulgarian borders by applying pressure on the Hungarians and Bulgar-

ians. This German guarantee, and the German effort necessary to support it, simply was never forthcoming. The Germans were, however, desperate for oil, and so were willing to pursue extensive economic agreements in Romania. Even without the German guarantee of the western and southern frontiers, however, it should be noted that down to 1939, there seemed to be some logic in the pro-German policy, at least to this extent: The Germans, based on every statement and formulation of Nazi ideology were anti-Communist and so anti-Soviet. So, to secure Romanian oil, the Germans could be counted on to keep the Soviets at bay. Also, if Romanian oil supplies and regularity of supplies could be counted on to keep the Germans out of any Hungarian-Romanian or Bulgarian-Romanian conflict, then a rearmed Romania might be able to take care of its own defense to that extent.

At the same time, Carol II did not immediately abandon relations with the French, which were preferred by most responsible Romanian political and military figures. They simply were left unstressed, and the French, through ennui, did the rest by neglecting to support the Little Entente in the moment of crisis, and by failing to deliver weapons in a timely fashion.

The bankruptcy of this policy was only fully revealed in August and September, 1939, when the Germans and the Soviets proved that their differences were not unbridgeable when there was plunder to be had. The Nazi-Soviet Pact of August, 1939, provided for the dismemberment of Poland, thus depriving Romania of yet another of its security guarantors. At the same time, the Germans disclaimed any intention of preventing Soviet occupation of territories formerly held by the Tsars. Thus, the Romanians were abandoned to the Soviets by the Germans, should the Soviets elect to claim Bessarabia. At exactly the same time, the Germans suggested to the Hungarians that they might begin to press their claims against Romania as a means of securing Romanian acquiescence in the invasion of Poland.<sup>37</sup>

The plundering of Romania was, however, delayed until after the fall of France. The Soviets demanded and received Bessarabia and part of Bukovina, which had never been part of Tsarist Russia, in June, 1940.<sup>38</sup> Almost immediately thereafter, in July and August 1940, the Bulgarians and Hungarians compelled, with German and Italian support, Romanian abandonment of much of the territory won in the Second Balkan War and World War I.<sup>39</sup>

Instead of securing Romania, Carol II's policy had left the Kingdom of Romania diplomatically isolated, vulnerable, and ultimately, plundered by its neighbors. The Greeks, Turks and Yugoslavs all declined to intervene on Romania's behalf, and so the alliance system of Romania had completely failed to save it. The immediate effect of these territorial losses was the collapse of the Romanian govern-

ment. None of the pre-war civilian politicians would form a government under Carol II, who was regarded as thoroughly discredited. Upon German advice, Carol II appointed Ion Antonescu, whom he had imprisoned as unreliable, as Prime Minister on September 4, 1940, to govern in conjunction with surviving members of the Iron Guard. After an abortive attempt to overthrow and assassinate his own Prime Minister, Carol II was forced to abdicate in favor of his son, Mihai, two days later. No one was particularly sorry to see the King depart.<sup>40</sup>

Though the Germans could scarcely be said to have been good friends to the Romanians under these circumstances, the second outcome of this maneuvering was, paradoxically, the closer alliance of the Germans and the Romanians. Antonescu, though personally pro-British and French in inclination, viewed the Germans as the only possible Great Power protector of the Romanians. Antonescu, coming into office in a difficult situation, was immediately forced to pursue two policies to stabilize the nation's military and diplomatic situation, and he had no choice but to rely upon German support for both efforts. Antonescu had first to upgrade the Romanian military, which, chronically under-equipped to begin with, had managed to lose even more equipment in the hasty withdrawals from Bessarabia and Transylvania. Second, Antonescu had to implement some sort of diplomatic initiative designed to recover Transylvania from Hungary, Bessarabia from the Soviet Union, or both.

Upgrading the Romanian military was made somewhat easier by the insatiable need of the German war machine for oil. The Germans had no products which they could trade for oil, and were sufficiently afraid of a joint Allied-Romanian effort to sabotage the oil fields and refineries to be dissuaded from any attempt to seize the oil by force. Therefore, the Germans were obliged to deliver military equipment to the Romanians. The Italians, incidentally, were in an even worse position, for even their military equipment was unattractive to the Romanians. They became, therefore, a cash customer.

The Romanians had been largely equipped by the French and the Czechs before the war. The Germans honored existing Czech contracts, especially for the delivery of light tanks. After the fall of France, the Germans found themselves in possession of a certain amount of French equipment, some of which was given to the Romanians. To this was added new German equipment, especially artillery, in an effort to upgun the Romanian artillery, armored cars, and anti-tank weapons.<sup>41</sup>

The principal beneficiary of this activity was, however, the Romanian air force. The Germans supplied several squadrons worth of Bf-109 fighters, and a variety of bombers, as well as some French and Polish aircraft to be used in a ground strike

role. The Romanians were able to supplement this with a very good locally produced fighter, the IAR 80/81.<sup>42</sup>

Despite the German effort, the Romanians could never quite upgrade their forces to the same standard as the Germans, Soviets, or even the Hungarians. The Germans found it difficult to produce for their own munitions needs, and so the Romanians received mostly left-overs, at least for the land army. The air force guarding the oil fields was, of course, a different matter. By 1942, the Romanians were able to upgrade about half of their army, and so accordingly divided it in halves, with the refitted portion going to the Eastern Front. Even before the debacle at Stalingrad, the arrangement provided a convenient excuse to avoid enlarging Romanian participation.<sup>43</sup>

The Romanians also received a technical mission from the German army and air force. These were of some value for training, and also supplemented the Romanian anti-aircraft defenses around the vital oil producing facilities. Though the Romanians welcomed the weapons and advice on German techniques, the German mission exerted less influence upon Romanian planning than the French had in World War I, and were largely kept ignorant about Romanian political machinations. As a result, the Germans were taken completely by surprise when the Antonescu regime was overthrown on August 23, 1944.<sup>44</sup>

The Romanians also relied upon the Germans for post-war border rectification, while attempting to maintain contact with all of the Allied powers with whom they were, to a greater or lesser extent, at war. Antonescu understood that the Romanian occupation of Bessarabia in June, 1941, depended entirely upon either a German victory over the Soviet Union, or Allied concessions in the event of peace. He also hoped that the Romanian military performance, visibly better than either the Hungarian or Bulgarian efforts, might lead to a German reconsideration of the value they placed on their minor allies. However, the determination with which Antonescu pursued the war with the Soviet Union did not extend to other pro-Axis policies. He had no particular ideology beyond the maintenance of domestic peace and quiet, and the maintenance of Romanian national integrity. In the aftermath of the Pearl Harbor attack, Antonescu told reporters, "I am the ally of the Germans against Russia; I am neutral between Great Britain and Germany, and I am for the Americans against the Japanese." This was hardly the ringing endorsement likely to inspire confidence in Romania among the other Pact of Steel members.<sup>45</sup>

After the German defeat at Stalingrad, the Romanian government concluded that the Germans would not win. Both the regime and the opposition, made up of the pre-war democratic politicians of the Liberal and Peasant Parties, began

searching for a means of exiting the German alliance. This ultimately proved fruitless, as the Western Allies referred the opposition leaders to the Soviet Union, and Antonescu refused to deal with the Soviets, though he was offered better terms than those ultimately received by the government that replaced him. In August, 1944, the King of Romania deposed and arrested Antonescu, and formed an all-party government to negotiate a peace with the Allies.<sup>46</sup> This diplomatic effort lies outside the scope of this paper, except to note that the Romanians recovered the territory lost to Bulgaria and Hungary, but not the territory lost to the Soviet Union. In essence, this became the modern Romanian border of 2006. It should be noted at this writing, in July, 2006, that a series of border disputes between Ukraine and Romania have been reported.

## **Conclusions**

1. The Romanian government has hitherto been interested in the problems of obtaining and maintaining independence, and of building a state that includes the Romanian ethnic community. This has led to conflict with the near neighbors of Romania in the past. Though in 2006 Romania disclaims interest in the Republic of Moldova, the former Bessarabia, there remain border difficulties with the Ukrainians to prevent this from being merely a matter of historical interest.

2. The Romanians are attentive to the problems of military defense, and have been willing to attempt to maintain military forces beyond the capacity of the country to support. Corruption has sometimes prevented military expenditures from being used efficiently. In the event of war, this sometimes impairs Romanian military performance, but the Romanian military has, despite all difficulties, proven willing to defend the country.

3. Because of the geographic position of the country, with potential enemies close at hand, and potential allies further away, the government of Romania has been forced to maintain military strength coupled with alliances to western Great Powers. There are preferred and non-preferred Romanian allies. Despite preferences for alliance partners, the Romanians are willing to retain an ally beyond the apparent national interest, and to discard an ally if national interests are not being met.

The exploration of Romanian defense policy, and some implications and opportunities for the United States is the subject of Major Schumann's paper. The exploration of Romanian foreign policy, and the theory which explains it, and may predict it, is the subject of Mr. Florea's paper. Romanian cultural preferences in alliance making are explored by Mr. Hariton.

## Endnotes

- 1 Central Intelligence Agency, *The World Factbook*, 2006 'Romania,' <https://www.cia.gov/cia/publications/factbook/geos/ro.html>
- 2 Keith Hitchins, *The Romanians: 1774-1866* (Oxford: Clarendon Press, 1996), 293-295.
- 3 Hitchins, *The Romanians: 1774-1866*, 316, and Hitchins, *Romania: 1866-1947*, 15-21.
- 4 Nicholas Constantinesco, *Romania on the European Stage, 1875-1880: The Quest for National Sovereignty*, (Boulder, Colorado: East European Monographs, 1998), 85.
- 5 Hitchins, *Romania: 1866-1947*, 44-47.
- 6 *Ibid.*, 48-53.
- 7 *Ibid.*, 137, 146-154.
- 8 *Ibid.*, 251-254.
- 9 *Ibid.*, 260-261.
- 10 *Ibid.*, 262, Larry Watts, *Romanian Cassandra: Ion Antonescu and the Struggle for Reform, 1916-1941*, (Boulder, Colorado: East European Monographs, 1993), 46.
- 11 Hitchins, *Romania: 1866-1947*, 263.
- 12 *Ibid.*
- 13 *Ibid.*, 263-265, and Kurt Treptow, ed., *A History of Romania*, (New York: Columbia University Press, 1996), 370, 376, Watts, 20-21.
- 14 Watts, 21-23.
- 15 Treptow, 379, 381, 383-384.
- 16 *Ibid.*, 388-89.
- 17 Those who are curious about the Romanian approach to the problem may wish to refer to Irena Livezeanu, *Cultural Politics in Greater Romania: Regionalism, Nation Building and Ethnic Struggle, 1918-1930* (Ithaca, N.Y., Cornell University Press, 1995)
- 18 Mark Axworthy, et. al., *Third Axis, Fourth Ally: Romanian Armed Forces in the European War, 1941-1945*, (London: Cassell, Arms and Armour Press, 1995), 239-245, and Watts, 46-47.
- 19 Watts, 47.
- 20 Watts, 46-47. According to Axworthy, in the period in question, SET delivered 30 aircraft, and IAR delivered 184 aircraft, under a French license, Axworthy, 239, 241.
- 21 Watts, 47.
- 22 *Ibid.*, 48.
- 23 *Ibid.*, 49.
- 24 *Ibid.*, 48, and Axworthy, 31-33 and 37-40.
- 25 Dov B. Lunga, *Romania and the Great Powers, 1933-1940* (Durham, N.C.: Duke University Press, 1989), 7.
- 26 *Ibid.*, 7-8.
- 27 *Ibid.*, 41-43.
- 28 Watts, 76-81.
- 29 Lunga, 124-125.
- 30 *Ibid.*, 9.
- 31 *Ibid.*, 30-33.



32 Ibid., 70.

33 Ibid., 9, 19.

34 Ibid., 24-29.

35 Ibid., 80-82.

36 Lest any one harbor illusions of Edward VIII of the United Kingdom renouncing his throne “for the woman he loved,” it should be noted that Carol II renounced the throne, then jilted “the woman he loved,” as well as his wife, Queen Helena, then took up with another woman he loved, whom he introduced into the Royal Palace in 1930 over the howling objections of most of the political figures of the day of all parties.

37 Nicholas Constantinesco, *Romania in Harm's Way: 1939-1941*, (Boulder, Colorado: East European Monographs, 2004.), 76-85.

38 Ibid., 140-150.

39 Ibid., 183-187.

40 Axworthy, 23.

41 Ibid., 31-42 and, generally.

42 Ibid., 232-289.

43 Ibid., 77-79.

44 Ibid., 26-27, 278-279.

45 Hitchins, *Romania: 1866-1947*, 474.

46 Ibid., 499-500.



## Post Cold War US Security Assistance to Romania and the Problem of the 'Double-Security Guarantee'—A Romanian Perspective<sup>1</sup>

Adrian Florea—Iowa State University

### Introduction

United States (US) security assistance programs constitute principal instruments for advancing military cooperation with key US allies and partners and, thus, for promoting the larger US foreign policy goals. Efficient US security assistance allocations, however, should be predated by a clear evaluation of long-term US security interests, an accurate assessment of existing and future security challenges, and a thorough understanding of recipient countries' geopolitical and normative orientations. In fact, due to the nature of the current global and regional threats, the very concept of *security* necessitates a significant reconceptualization in order for US security assistance programs to be effectively employed.

During the Cold War period, security represented a static, monolithic concept and was mainly substantiated in great power deterrence actions. The post Cold War international milieu poses for the United States security challenges which are no longer concentrated, but diffuse, not necessarily traditional, but overwhelmingly asymmetric. Today's realities require a more comprehensive view of security, one tailored after the complex nature of the regional and global threats. Security issues do manifest themselves in various ways, which makes futile any attempts at coming up with an exhaustive conceptualization of security as a theoretical paradigm. However, security remains a major concern of nation-states. Nowadays, security issues manifest themselves not necessarily in terms of deterrent actions but in terms of projections of power and influence over geopolitical spaces that are structurally, normatively and strategically vital to a state's short and long-term interests. Given its global and regional posture, the United States needs to adopt a more systemic approach to security policies, one that would be informed by interests and capabilities, and would be solidified by bilateral and multilateral cooperative frameworks. US policy-makers should be cognizant of the fact that security conceptualizations arise from specific regional and global contexts, which shape the way state and non-state actors perceive threats and challenges. Despite its impressive hard and soft power, the US cannot unilaterally deal with all existing and emerging threats. Therefore, forging close bilateral security ties with reliable and capable partners represents a necessary condition for ensuring security and stability, and US security assistance programs provide American policy-makers with various instruments for strengthening strategic partnerships with key countries.

A systematic allocation of US security assistance requires sensible policies and a strong US commitment to strategic partnerships with key allies and friends. Solid strategic alliances should be based on considerations such as the partner country's *location, geopolitical orientation, capabilities* (both existent and potential) and *normative characteristics*, and should be constantly supported by adequate appropriations of US security assistance funds. In the post Cold War period, Romania has gradually emerged as a reliable US ally, as a strategic partner willing and capable to engage in US-led global and regional operations at a high level of sophistication. Compelling arguments regarding Romania's *strategic location, security orientation, military basis, and ideological make-up*, militate in favor of an enhanced US-Romanian security partnership. In order to cement a partnership of vitality and relevance, and to benefit from an invaluable strategic asset in a potentially volatile region, the United States has at its disposal a plethora of instruments, among which US security assistance programs stand out as fruitful means for achieving strengthened and mutually-beneficial strategic relations with Romania. Therefore, this paper posits that a principled and substantial enlargement of the scope of US security assistance to Romania would be conducive to the promotion of US security interests in the region, and to the development of a comprehensive cooperative framework that would serve the long-term interests of both countries.

The first part of the analysis briefly reviews US-Romanian security relations from a historical perspective. The second section emphasizes Romania's geostrategic potential, whereas the third section addresses the normative aspects that should guide the allocation of US security assistance funds for Romania. The fourth part presents the details of post Cold-War US security assistance to Romania, while the fifth part advances some policy recommendations regarding future allocations of US security assistance funds for Romania. The conclusion restates the main argument put forth in this study, namely that expanding the scope of US security assistance to Romania would fulfill long-sought Romanian structural and ideological needs and would be in the long-term interest of both countries.

### **Overview of US-Romanian Security Relations**

The United States and Romania first established diplomatic relations in 1880 at legation level. The diplomatic interactions were upgraded to embassy level in 1964. During the communist period, diplomatic and military contacts had a limited scope. After Romania returned to democracy in 1989, US-Romanian relations strengthened, leading to US support for Romania's integration into the transatlantic and European structures. Romania was the first post-communist country to join (in 1994) the Partnership for Peace program. In 1997, Romania and the United States signed a Strategic Partnership, as an advanced mechanism for consolidating the

bilateral security relations. The partnership deepened after 2001 with the conclusion of a Status of Forces Agreement (SOFA) in 2001, the signing of an Article 98 Agreement in 2002 regarding the protection of US persons operating on Romanian territory from surrender to the International Criminal Court, and Romania's NATO accession in 2004.

The increased congruence of US-Romanian security perceptions has been conducive to closer military ties and the development of a broad strategic relation with the US, which was substantiated by broad logistic and operational cooperation during US-led military operations in Afghanistan and Iraq<sup>2</sup>, and by the signing of a base agreement in 2005. Romania has enthusiastically granted over-flight rights, and made available land, air, and maritime facilities to support US operations in Afghanistan and Iraq. Romania has responsibly engaged within the broader anti-terrorism campaign by offering unwavering and unrelenting military support to Operations ENDURING FREEDOM<sup>3</sup> and IRAQI FREEDOM.<sup>4</sup> Romania and the US are also closely working together to promote stability and security in the Balkans and Black Sea region.

The base agreement of 2005<sup>5</sup> represents a solid stepping stone for a long-term, enhanced US-Romania partnership. According to the agreement's provisions, approximately 2,300 US troops will be deployed in Romania.<sup>6</sup> A US base will be set up in a convenient location (M. Kogalniceanu<sup>7</sup>) and will enable American troops to practice command and control operations over large areas.

The base agreement is part of the larger US Department of Defense (DOD) strategy of deploying small, flexible, agile, and expeditionary forces to strategic pivot points, i.e. to locations moderately close to volatile regions around the globe. The realignment of US global defense posture signals a departure from a static Cold War ideology, which emphasized the importance of concentrating troops and capabilities in a few large locations, to a post-Cold War dynamic approach, which is focused on smaller bases situated in several strategic locations that enable US forces to be more expeditionary and deployable. In the new base policy framework, US troops are not expected to fight in place; on the contrary, the emphasis is placed on surging forces from a global posture<sup>8</sup> and swiftly deploying them to crisis regions. This new course of action necessitates a systematic approach to security relations with host states which would include considerations such as geographical location, capabilities, geopolitical orientation and normative characteristics.

Romania is strategically located, has a good military basis, shares a common security zeitgeist with the United States, and is determined to play a paramount role in ensuring regional and global stability. Therefore, forging complex security

ties with Romania is in the long-term interest of the United States and Washington should broaden its security assistance programs to Romania in order to solidify the strategic partnership with its key ally.

### **Romania As Regional Stability Provider**

The geographical location confers Romania a strategic advantage for projecting regional stability and promoting intra- and inter-regional cooperation. The country is located at the intersection of three strategic spaces: Central and Eastern Europe (a site of regional prosperity); Central Asia-Caucasus (a region chronically unstable and potentially explosive, and a zone undergoing a prolonged identity crisis); and the Black Sea (an area of strategic importance for NATO's southern flank, and an energy bridge between Europe and Central Asia/the Middle East).

Benefiting from a significant geostrategic potential, Romania is determined to emerge as a pillar of stability in the area, and to serve as a security bridge between Eastern Europe, Central Asia and the Middle East. Romania is playing a pro-active role as a regional security provider and as a powerful catalyst for regional cooperation<sup>9</sup>. Ensuring stability, security and development in a multi-textured region requires firm commitments from regional and global players. Romania is directly interested in playing an active and constructive role in the region, thus contributing to a favorable security climate in the Black Sea-Central Asia-Middle East area.

The Black Sea zone represents a strategic connector binding the transatlantic community (as security provider and energy consumer) to the Central Asia-Caspian Sea-Middle East space (as energy provider and security consumer)<sup>10</sup>—a space characterized by WMD proliferation, arms, drugs and human trafficking, cross-border crime, endemic corruption, democratic deficit, and frozen regional conflicts.<sup>11</sup> Romania has already substantiated its readiness and capacity to counter regional security threats by contributing to the stabilization efforts in Bosnia and Kosovo, and by working as a political bridgehead on security aspects regarding the Black Sea region and adjacent areas. The larger environment surrounding Romania is still prone to conflicts and asymmetric threats with potential spillover effects and severe implications for regional peace and security. Regional conflicts may become more frequent and their direct or cumulated effects harder to control.<sup>12</sup> Bolstering the stability of a region prone to asymmetric security manifestations necessitates appropriate military, political and economic configurations. Enhanced bilateral and multilateral defense cooperation initiatives are, therefore, necessary in order to secure the regional security.

As a NATO member and staunch US ally, Romania is committed to contributing, politically and militarily, to the stability of the area, and to securing a *strategic corridor*<sup>13</sup>, stretching from the Baltic Sea to the Black Sea which will: secure US and NATO operational access; enhance US and NATO operational and logistical maneuverability; hedge against potentially explosive conflicts and renewed great power confrontations; and contribute to the prevention of asymmetric and transnational risks.

Given its capabilities and security orientations, Romania is an important element of this *strategic buffer zone* whose structural characteristics are congenial to US interests. The US-Romanian partnership gives relevance and vitality to an already cooperative framework along this corridor. Multilateral and bilateral interactions, corroborated with the projected American military presence in the area will substantially contribute to the stability of the region. An enhanced US-Romanian relation will provide an impetus for cultivating a regional security climate that is consonant with overlapping American and Romanian strategic interests. However, a long-term strategic US-Romania partnership requires not only common security perceptions, but also complex diplomatic and military interactions that would fulfill the structural and ideological needs of both countries. If sensibly implemented, US security assistance programs have great potential for contributing to the fulfillment of those needs for both the US and Romania.

### **Transformational Diplomacy and the Problem of the ‘Double-Security Guarantee’**

Under the aegis of a new conceptualization of inter-state relations and interactions—*transformational diplomacy*—the United States government has acknowledged the importance of adopting a more comprehensive diplomatic and military posture in the 21st century. As formulated by Secretary of State Condoleezza Rice, transformational diplomacy means working “with [ ... ] many partners around the world to build and sustain democratic well-governed states that will respond to the needs of their people and conduct themselves responsibly in the international system”.<sup>14</sup> Transformational diplomacy presupposes a different conceptualization of diplomatic relations, one that is informed not necessarily by balance of power considerations, but by the domestic, ideological and political characteristics of regimes within states. Thus, transformational diplomacy signals a fundamental change in how the US government perceives inter-state relations. The focus of the new approach is placed on understanding (and changing, if necessary) the domestic processes that serve as the main determinants of states’ projections in the international system, rather than on merely shaping relations among states. At a more specific level, a ‘transformational’ posture implies increased awareness of

the normative and structural elements that govern states' international behavior. A 'transformational' understanding of the reasons behind states' global or regional projections presupposes a multi-layered analysis of the internal and external components that determine a country's international stance.

As far as security assistance is concerned, a transformational approach requires not only accurate assessment of states' security choices, but also increased awareness of states' ideological and strategic needs that underlie those choices. Therefore, in order for US security assistance to allies and friends, such as Romania, to be productively employed, security assistance decisions should be carefully tailored according to both US strategic needs and interests, as well as to recipient countries' normative and political characteristics. In other words, thorough assessments (on a country-by-country basis, rather than on a regional basis) of the strategic and normative particularities of each recipient of US security assistance should predate any decision regarding funds allocation, and should lay the groundwork for the institutional implementation of a more pragmatic approach to US security assistance. Security assistance, as preventive action<sup>15</sup>, will be an invaluable vehicle for strengthening alliances and partnerships only through development of accurate and comprehensive security assessments for each recipient country.

In the case of Romania—regional security provider and reliable US partner—a clear assessment of the ideological and political components that determine the country's strategic alignment must precede any institutional decision regarding the scope of US security assistance. It is instructive to point out that, throughout modern history, the Romanian quest for a *double security guarantee*, i.e. security through a) *great power guarantees* and b) *reliance on internal defense sources*, has dominated the country's projections in the international system. The double security concern, as a historical and ideological development, has been the foundation of Romania's security policy since 1877. As a conceptual paradigm, the double security guarantee postulates that a great power bilateral alliance, based on strong military interactions, represents a *sine qua non* condition for preserving Romania's sovereignty and integrity. From a Romanian perspective, a great power security guarantee is to be substantiated in a comprehensive bilateral relation, with a dominant military component<sup>16</sup> that would be critical for enhancing the internal defense capabilities.

Due to various political circumstances and contingencies, Romania has also attempted to join multilateral alliances in lieu of (or in addition to) a strong bilateral alliance with a great power. Nevertheless, the multilateral alliance alternative has historically been politically and psychologically ineffective in satisfying the larger security goals of the Romanian military and political establishment. For Romania,



the multilateral alliance system has traditionally been a necessary but not sufficient condition for securing the country's strategic needs and interests.

The preoccupation for a double security guarantee has dominated the country's security policies ever since its formal independence in 1877. In 1859, the principalities of Wallachia and Moldavia secured their autonomy from the Ottoman Empire, and in 1859 united to form a nation-state under the name of Romania. After unification Romania proclaimed its independence from the Ottoman Empire in 1877, and joined Russia in the war against the Ottomans (1877-1878). Following the Russian-Romanian-Turkish War, Romania's independence was recognized by the Treaty of Berlin (1878).<sup>17</sup> Internally, the intense struggle during the war of independence and the subsequent alliance with Russia against the Ottomans<sup>18</sup>, has ideologically inculcated within the political and military class the realization that ensuring Romania's security and stability in a volatile region requires an adept strategy based on: a) boosting the internal defense capabilities; and b) securing a close alliance with a great power. This doctrine of a double security guarantee would become the main pillar of Romania's international interactions after 1877. After independence, the new Romanian state (located at the confluence of the Ottoman, Austro-Hungarian, and Russian empires) looked towards France for its military, administrative, and cultural models. During WWI Romania joined the Entente, hoping to regain Transylvania from the Austro-Hungarian Empire and integrate it into the "Greater Romania", and to fulfill its security needs by building a close bilateral partnership with a Western power.

During the inter-war period (1918-1939) both internal and external causes limited Romania's attempts to ensure a desired double-security guarantee. Internally, societal and economic development was corroborated with political turmoil<sup>19</sup> and the rise of nationalistic sentiment; externally, despite (or because of) the country's penchant for comprehensive security commitments, Romania did not manage to ensure a strategic partnership with a Western power, thus leaving unrealized its quest for great power security guarantees. Moreover, in 1939, Germany and the Soviet Union signed the Molotov-Ribbentrop Pact, which reflected (among other things) the Soviet territorial designs over Bessarabia<sup>20</sup> and Bukovina.<sup>21</sup> As a result of the Soviet interest in capturing Romanian territory, the country looked for available great power security guarantees and entered WWII on the side of Germany. Following the overthrow of the pro-German Antonescu dictatorship in August 1944, King Mihai reversed course and put Romanian armies under Soviet command. Soviet occupation after WWII led to the forced abdication of King Mihai (who went into exile) and the establishment (in 1947) of a communist republic under the influence of the Soviet Union. In 1967, Ceausescu became head of state, instituted a draconian dictatorship, and following the 1968 invasion of Czechoslo-

vakia, attempted to assert some independence from the Soviet Union. In December 1989, the communist regime collapsed and the new democratic Romania began to look to the West for strategic partners. The double security paradigm reemerged as a dominant ideology in a post Cold-War environment dominated by a resurgence of great power regional hegemonic attempts. The multilateral alliance security ‘necessity’ was accomplished in 2004 when Romania joined NATO<sup>22</sup>; furthermore, the country is currently making great strides towards fulfilling its historical double security objectives: it is responsibly restructuring its defense forces and increasing its military capabilities, and it is making tremendous efforts towards forging a close, comprehensive relationship with the United States of America.

The example of the historical double security concern for Romania illustrates the fact that US security assistance should pragmatically embed military concerns in broader ideological and political notions. To a large extent, security assistance, as a staple of US foreign policy strategy, represents a vector for regional stability. Building functional defense complementarities with allies and friends through security assistance requires a clear understanding of the recipients’ defense postures and strategic alignments. By pursuing a historical security objective—a great power security guarantee—Romania is committed to a long-term strategic partnership with the United States, based on enhanced military interactions which are aimed at preserving regional and global stability. In the face of new threats to international security, the US-Romania alliance is a partnership of vitality and relevance informed by broad security complementarities, congruence of security perceptions, and strategic alignment of capabilities, strategies, and doctrines. Consequently, attention given to Romanian desires to enhance internal defense capabilities and to serve as a long-term US ally provides an opportunity for the United States to develop a more capable and reliable partner. A principled reconsideration of the scope of US security assistance to Romania would enable the United States to appropriate foreign assistance funds effectively and to gain a valuable asset in a potentially volatile region.

### **Overview of US Security Assistance to Romania**

Effective allocation of US security assistance requires not only adroit diplomacy, but also a prescient analysis of recipient countries’ strategic posture and capacity to efficiently administer funds. US security assistance represents an important tool for shaping the strategic alignment and security contours of recipients. The introduction of the United States Security Assistance Programs (USSAP) to the Romanian Ministry of National Defense (RoMND) has been a transformative moment for the military relations between the two countries. In 1996, auspicious

developments in the US-Romanian bilateral relations have been conducive to the inclusion of Romania in US security assistance programs.

Even though immediately after 1989 there had been relevant military contacts between the two countries, Romania was able to fully demonstrate its commitment to Western ideals only in the mid-1990s, and therefore to start benefiting from US security assistance in 1996. This period coincided with a realization in the West of Romania's regional strategic position in the face of renewed regional hegemonic attempts, and of Romania's determination to join the North Atlantic Treaty Organization and, thus, to be part of the Western security architecture. Between 1996 and 2004, US security assistance<sup>23</sup> to Romania has been moderate and mainly allocated through Foreign Military Financing (FMF)<sup>24</sup> and International Military Training and Education (IMET) programs.<sup>25</sup> After 2001, bilateral relations between the United States of America and Romania intensified to culminate in a broad strategic partnership which includes NATO membership, joint combat operations in several theaters of operations (e.g. Afghanistan and Iraq), and a base agreement to name but a few momentous developments. Romania's resolve to play a more active role as a regional security provider, as well as Romania's significant contribution to the Operations ENDURING FREEDOM and IRAQI FREEDOM did not translate into a significant increase in the scope of US security assistance for the country. US security assistance<sup>26</sup> for 2005, 2006, and 2007<sup>27</sup> has remained at about the same moderate ceiling (see Table 1 and Table 2 below<sup>28</sup>), and has been mainly allocated through FMF and IMET programs.<sup>29</sup>

**TABLE 1. US SECURITY ASSISTANCE TO ROMANIA 2005-2007 (\$ IN THOUSANDS)**

Account	FY 2005 (actual)	FY 2006 (estimate)	FY 2007 (request)
<b>FMF</b>	13,412	12,870	15,000
<b>IMET</b>	1,575	1,485	1,580
<b>CSH<sup>30</sup></b>	2,000	-	-
<b>NADR<sup>31</sup></b>	750	75	-
<b>SEED<sup>32</sup></b>	28,500	19,800	-
<b>Other (Peace Corps)</b>	2,887	2,959	2,950
<b>Total</b>	<b>49,124</b>	<b>37,189</b>	<b>19,530</b>

**TABLE 2. FMF AND IMET ASSISTANCE TO ROMANIA 2005-2007 (\$ IN THOUSANDS)**

Account	FY 2005 (actual)	FY 2006 (estimate)	FY 2007 (request)
<b>FMF</b>	13,412	12,870	15,000
<b>IMET</b>	1,575	1,485	1,580
<b>Total</b>	<b>14,987</b>	<b>14,355</b>	<b>16,580</b>

At a general level, FMF provides grants for the acquisition of US defense equipment, services and training “which promotes US national security by contributing to regional and global stability.”<sup>33</sup> These grants enable recipient countries to “improve their defense capabilities and foster closer military relationships between the US and recipient nations.”<sup>34</sup> The main objectives of FMF programs<sup>35</sup> are: “to improve the military capabilities of key friendly countries; enhance rationalization, standardization and interoperability of military forces of friendly countries; and to boost legitimate defense needs of friendly countries.”<sup>36</sup>

At a specific level, FMF funds for Romania have so far supported: base modernization; strategic training;<sup>37</sup> tactical communications; digital mapping; equipment for Special Operations Forces (SOF); secure data management; navigational aids; the purchase of C-130 aircraft. FMF allocations have also been used for: training for conflict resolution and peacekeeping operations; resource management; noncommissioned officer (NCO) and officer professional development.

Another key component of advancing US national and foreign policy is the IMET program. IMET represents a major element of US security assistance “that provides military training and education on a grant basis to students from allied and friendly nations.”<sup>38</sup> IMET is specifically aimed at augmenting the capabilities of participant nations’ military forces to support combined, sophisticated operations and achieve interoperability with US, NATO and regional coalition forces. Through IMET programs, foreign militaries have the opportunity to solidify their knowledge of US military doctrine, strategic planning processes and operational procedures. The military-military and civil-military interactions provide several avenues for information sharing, joint planning, and combined force exercises that facilitate interoperability and ensure unity of effort.

IMET funds for Romania have so far supported: professional military education; special operations training; English language training; mobile training team development; contingency planning teams. In October 2005, the Defense Institute of Security Assistance Management (DISAM) returned to Romania nine years after introducing United States Security Assistance Programs to the Romanian Ministry of National Defense.<sup>39</sup> In cooperation with the RoMND and the US Office of Defense Cooperation in Bucharest (ODC)<sup>40</sup>, DISAM conducted several mobile education and training (MET) seminars.<sup>41</sup> The effectiveness of the IMET programs for Romania is visible in the number of students trained with IMET funds. The Romanian military benefits from highly trained personnel (regarding both the professional and foreign language education) who have been working assiduously to incorporate US military processes and procedures. As it can be seen from Tables 3, 4 and 5, out of three NATO-member countries receiving approximately the same

**TABLE 3. NUMBER OF ROMANIAN STUDENTS TRAINED WITH IMET FUNDS<sup>43</sup>**

IMET	FY 2005 (actual) – \$1,575,000	FY 2006 (estimate) - \$1,485,000	FY 2007 (request) - \$1,580,000
No. of Romanian students trained	512	488	521

**TABLE 4. NUMBER OF BULGARIAN STUDENTS TRAINED WITH IMET FUNDS**

IMET	FY 2005 (actual) – \$1,532,000	FY 2006 (estimate) - \$1,386,000	FY 2007 (request) - \$1,430,000
No. of Bulgarian students trained	121	111	118

**TABLE 5. NUMBER OF HUNGARIAN STUDENTS TRAINED WITH IMET FUNDS**

IMET	FY 2005 (actual) – \$2,013,000	FY 2006 (estimate) - \$1,559,000	FY 2007 (request) - \$1,480,000
No. of Hungarian students trained	111	87	99

amount of IMET financing, Romania has been able to train an impressive number of students.<sup>42</sup>

The analysis and figures above indicate that, for the past decade, US security assistance to Romania has been efficiently allocated and managed, but has not been sufficient in satisfying larger defense needs of the Romanian military. So far, US security assistance to Romania has focused on specific niche capabilities, but has not adequately addressed more complex quantitative and qualitative considerations regarding capabilities, interoperability and training standards. Given Romania’s firm, long-term commitment to a comprehensive partnership with the US, as well as Romania’s willingness and capacity to support US regional and global operations, it is in the interest of both countries to increase the scope of US security assistance in order to cement a strategic bilateral relation.

#### **US Security Assistance to Romania—Policy Recommendations<sup>44</sup>**

Building solid regional partnerships is at the heart of the transformational diplomacy envisaged by the US Department of State, and security assistance provides US policy-makers with several avenues for advancing regional peace and security. A successful US strategy for hedging against extant and emerging threats “requires improving the capacity of partner states and reducing their vulnerabilities”<sup>45</sup> in order to maintain a regional and global deterrent posture. Projecting US power at a global and regional level requires training, equipping and advising allies’ forces to generate stability and security; assisting partners with logistics sup-

port, equipment and transport to allow them to participate in security, stability, transition and reconstruction efforts; and, helping allies boost their capabilities in order to make them more agile and more expeditionary.<sup>46</sup> Thus, the security assistance program represents “one of the principle vehicles for strengthening alliances and partnerships”<sup>47</sup> and for developing greater flexibility and enhancing US global freedom of action.

However, ensuring regional and world security and stability in the context of a global intensification of asymmetric and traditional threats (originating with state and non-state actors) requires a more pragmatic reevaluation of US security assistance to key allies. A world dominated by diverse, asymmetric and disruptive security challenges requires that the US cooperate with reliable partners that are willing *and* capable of engaging in regional and global operations at a high level of sophistication. Romania has clearly shown its commitment to being not only a responsible consumer of security assistance, but also a major contributor to US operations. The convergence of Romanian and US security interests highlights the need for a more comprehensive, more inclusive approach to US security assistance to Romania, one that would solidify an invaluable partnership and that would be informed by both strategic and normative considerations.

Undoubtedly, enhanced US security assistance to Romania would enable the United States to spur the military transformation of a key ally, and would help shape a regional status-quo in ways congenial to US interests. A more inclusive paradigm for ensuring stability through comprehensive US security assistance to Romania would balance quantitative aspects regarding arms procurement and qualitative considerations related to training standards and interoperability, and might include the following policy directions<sup>48</sup>:

*Supporting a Principled Augmentation of Romanian Capabilities Through FMF, FMS and Related Programs*

Confirming its commitment to play the role of reliable NATO partner and regional security provider, Romania has embarked on the path towards the creation of credible and efficient defense capabilities. The stated goal of the RoMND is to build a “professional army with mobile and multifunctional expeditionary forces, swiftly deployable, flexible and efficient, capable to defend the national territory and to actively participate in international missions.”<sup>49</sup> The defense reform in Romania is aimed at the creation of a “smaller, modern, flexible, expeditionary and interoperable forces, able to deter and counteract threats to Romania and its allies.”<sup>50</sup> The augmentation of the Romanian defense posture, however, requires a military transformation at both the *capabilities* and *conceptual* levels.

In terms of *capabilities*, a long-term, sustainable security strategy for Romania requires significant foreign acquisitions and modernization projects, plus the maintenance and development of a solid domestic defense industry.<sup>51</sup> In order for Romania to have the capacity to confer, as key US ally, such features as operability, flexibility, and operational efficiency, US security assistance programs (especially FMF and FMS) could be employed to fill critical capability gaps. More specifically, increased FMF and FMS allocations could be directed towards:

- *Modernizing the arms procurement system.* Procurement of new combat and transport aircraft<sup>52</sup>, air defense systems, armored vehicles, littoral combat ships would enable Romanian forces to be better prepared for wider asymmetric challenges and to hedge against systemic uncertainties.
- *Finalizing navy equipment programs, upgrading military facilities and implementing the C4I systems.* These developments would undoubtedly contribute to the enhanced operational readiness of Romanian forces.
- *Facilitating defense agreements with the participation of the Romanian defense industry.* Complex interactions between US and Romanian defense companies<sup>53</sup> would create a framework for increased cooperation in key defense aspects, such as infantry<sup>54</sup> and armored vehicles upgrading.

At the *conceptual* level, US security assistance financing could be oriented towards: training Romanian units to better align operational strategies with available resources and to integrate efforts into a unified strategy; developing mobile, flexible and adjustable command and logistic structures; conveying strategies to balance current and anticipated security needs and projected future capabilities.

#### *Enlarging the Scope of IMET Programs for Romania*

An increased level of interoperability between Romanian, US, and NATO forces requires an adequate level of training, and IMET programs could provide a wide array of cooperative instruments aimed at training Romanian units for participating in: crisis management operations; anti-terrorism campaigns; peace-keeping operations; rescue missions; high intensity combat operations; littoral and unfavorable terrain missions. The goal of IMET programs for Romania is to support the development of deployable Romanian forces with high level of readiness—forces which are self-sustainable and jointly operational. In today's international environment, securing access to key regional and global points and establishing favorable security conditions requires first and foremost strategic deployment of

agile, flexible, well-equipped and well-trained ground forces. “Military occupation and population control will remain human endeavors and will be less amenable to technological enhancement than any other aspect of war...As long as war remains a process of human beings interacting with one another—as all [ ... ] warfare is—the land-power “market” will require a heavy investment in people.”<sup>55</sup>

Investing in complex training for Romanian military units would create a valuable pool of trained and ready soldiers for US and NATO-led operations against state and non-state enemy combatants. Advantages in operational maneuver during traditional and asymmetric hostile actions derive from the integrated communication and action of ground, air and sea forces. US and Romanian ground troops are confronted in Afghanistan and Iraq with highly dispersed insurgent actions, which make manifest the current and future need for training small teams to conduct missions tailored to local conditions. Consequently, IMET-related programs could also be targeted at training Romanian Special Operations Forces (SOF) to perform demanding operations in hostile environments.

#### *Orchestrating Comprehensive Cooperation With US Defense Institutions*

A positive reevaluation of US security assistance to Romania should be carried out in a strategically sound and fiscally responsible manner. Military assistance should be transformed so as to achieve full integration of capabilities and doctrines. More importantly, it is critical that US assistance to Romania should be based on a solid framework that also includes an important institutional component.

Expanding the institutional basis of the bilateral US-Romanian military relationship necessitates a multi-layered, dynamic approach based on three key elements:

a. *Military education cooperation.* Military education represents a critical component of a comprehensive bilateral military relationship between Romania and the United States. Enhanced military education interactions between US and Romanian institutions<sup>56</sup> would accommodate the functional and strategic demands of an integrated command and operational doctrine.

b. *Resource management cooperation.* Effectively managing security assistance resources requires adequate, specialized training regarding the procedures and implementation of security cooperation programs.<sup>57</sup>



c. *Training cooperation.* Romania has a good military basis for expanding its bilateral relationship with the United States. However, at the operational level there is still a manifest need for a better alignment of US and Romanian training systems. The establishment of a Romanian National Training Center (RNTC)<sup>58</sup>, for instance, would be a good opportunity for training Romanian forces as professional opposing forces (OPFOR) and for conducting complex joint US-Romanian SOF training.

## **Conclusion**

In order to hedge against uncertainties, mitigate adverse effects, and establish favorable global and regional security conditions the United States needs to adopt a pragmatic, principled defense posture which would include dynamic, comprehensive partnerships with key allies. US security assistance remains one of the cornerstones of promoting US interests by improving the military capacity of partner states and, thus, by enabling the US to best employ the unique capabilities and characteristics of each ally. Security assistance presents unique opportunities for the US to overcome systemic crises by restructuring the global and regional configurations of power.

US security assistance programs expand the US global freedom to act. Through a resilient network of military alliances and partnerships, the US will be more capable to forestall the emergence of new threats and to be better prepared for traditional, irregular, catastrophic and disruptive challenges. Effective US security assistance generates stability and confers US forces greater flexibility, maneuverability, interoperability, and agility. However, efficiently employing US security assistance to promote US interests requires moving away from a static conceptualization of existing and future security conditions. The United States will accrue important benefits from its security assistance programs only by displaying a long-term commitment to strategic, comprehensive partnerships with key allies which the US could assist with equipment, logistics support, and training to allow them to participate as members of coalitions with the United States or its partners.

Given the security challenges of the 21st century, US security assistance should be approached around both a preventive and a responsive dimension. Moreover, US security assistance programs should underlie principled goals and pragmatic means. More importantly, allocation of US security assistance funds should be predated by a thorough assessment of each recipient's defense posture and normative characteristics. Recipients should be assessed individually, and elements such as location, capabilities, ideology and geopolitical orientation should inform any decision regarding US security assistance allocations.

In the past decade, Romania with its major geostrategic potential has emerged as a staunch US ally and as a catalyst for regional stability and development. By participating within US and NATO-led operations, Romania is also playing a paramount role in ensuring global security and stability. Romania's strategic partnership with the US represents an essential landmark of Romanian foreign policy and has been substantiated in Romania's capacity and readiness to assume its responsibilities as reliable US ally. US security assistance to Romania gives poignancy and strength to the bilateral partnership.

However, forging a durable and robust relation between the two countries requires responsible commitments from both sides. Romania, with its strategic location and geostrategic potential, could become an invaluable asset for promoting US interests in the region. There still remain numberless prospects for cooperation in the security sphere and US security assistance programs could be employed to enlarge the spectrum of closer and more comprehensive security ties. As this analysis has indicated, the convergence of US-Romanian normative views on interstate relations, as well as overlapping security concerns militate in favor of broader security interactions. The United States is becoming fully cognizant of the benefits of the strategic partnership with Romania. This realization should serve as a powerful catalyst for expanding the scope of US security assistance to Romania and for establishing a comprehensive cooperative framework that would serve the long-term interests of both countries. Comprehensive US security assistance to Romania, corroborated with the establishment of a US military base in the country, offers substantial strategic benefits: for Romania, it fulfills not only a long-sought security guarantee, but also a structural necessity; for the United States, it ensures maximal operational flexibility with limited costs, minimal limitations on US access, and a more solid defense posture of an ally capable and willing to actively participate in US and NATO-led operations both at a regional and global level.

## Endnotes

1 ©Adrian Florea, 2006. No part of this may be reproduced without prior permission from the author.

2 Romania is the central and eastern European country with the largest participation in US-led operations in Iraq and Afghanistan. See the number of troops deployed to Iraq and Afghanistan by each central and eastern European country in Table 6 below. (2006 figures; source: *The Economist*, June 24-30, p. 62).

**TABLE 6.** TROOP DEPLOYMENTS TO IRAQ AND AFGHANISTAN BY EACH CENTRAL AND EASTERN EUROPEAN COUNTRY.

Country	Troops in Iraq	Troops in Afghanistan	Total
Romania	960*	492	1452
Poland	550	105	655
Lithuania	120	115	235
Czech Rep.	96	100	196
Hungary	0	170	170
Latvia	122	29	151
Slovakia	105	17	122
Estonia	35	80	115
Bulgaria	0	66	66
Slovenia	4	49	53

\* Including 130 troops performing UN duties.

3 Romania's contribution to the operations in Afghanistan includes (but is not limited to): approximately 450 Romanian soldiers and 40 officers and NCOs; a military police platoon; 3 liaison officers; C-130 Hercules aircraft; armored vehicles. The Romanian military plans to augment its contribution to the process of extending ISAF across Afghanistan and to the establishment of new Province Reconstruction Teams. Source: *Romanian Armed Forces 2005*. Bucharest: Ministry of National Defense, Military Publishing House.

4 Romania's contribution to the operations in Iraq includes (but is not limited to): approximately 850 Romanian soldiers; a medical team (20 doctors and medical staff) serving the US Field Hospital in Abu Ghraib; 100 Romanian soldiers within the UN Protection Mission Force in Iraq. Romania has recently increased its participation to the Iraqi theater by deploying a company to support UN protection missions and by enhancing its contribution to the NATO Training Center in Rusimayah. Sources: *Romanian Armed Forces 2005*. Bucharest: Ministry of National Defense, Military Publishing House; Romanian Ministry of National Defense website - <http://www.mapn.ro/> (accessed June 29, 2006).

5 The United States has also signed a base agreement with Bulgaria in 2006.

6 Bulgaria will host approximately 2,700 US troops; however, the joint command of the Romanian and Bulgarian units will be in Romania. The bases in Romania and Bulgaria are part of the larger reorganization of U.S. forces overseas known as the Military Global Posture Review.

7 US troops will be stationed in M. Kogalniceanu, near the seaport of Constanta; in addition, the firing ranges in Babadag, Cincu and Smardan will be made available to US forces.

8 Cf. the *National Defense Strategy* of the United States of America, 2005, p.18.

9 Romania is party to a dense web of regional cooperation projects, such as: the Organization for Security and Cooperation in Europe (OSCE); South-Eastern Europe Defense Ministerial (SEDM); Black Sea Naval Cooperation Task Group (BLACLSEAFOR); the Multinational Engineer Battalion (TISA); Central European Nations' Cooperation in Peacekeeping (CENTCOOP); Southeast European Cooperation Process (SEECP).

10 Cf. the *National Security Strategy of Romania*, 2006.

11 Transdnistria, Abkhazia, South-Ossetia, Nagorno-Karabakh, Chechnya and Dagestan are some proximate regions prone to explosive conflicts.

12 *National Security Strategy of Romania*, 2006, p.6.

13 The so-called *strategic corridor* coincides with NATO's eastern border which is made up of the following countries: Estonia, Latvia, Lithuania, Poland, Slovakia, Hungary, Romania and Bulgaria.

14 Speech on transformational diplomacy given by Secretary of State Condoleezza Rice at the Georgetown School of Foreign Service (January, 18, 2006).

15 The *National Defense Strategy* (2005) of the United States of America specifically labels security assistance as an important preventive component of US foreign policy.

16 The principle of complex reciprocity, i.e. enhanced mutual support in various regional and global endeavors, is a key characteristic of a comprehensive bilateral alliance.

17 The Treaty of Berlin (1878) made Romania the first national state in Eastern Europe.

18 Following the Russian-Romanian-Turkish War, Romania was forced to cede southern Bessarabia to Russia. Although initially hoping to develop a close alliance with Russia, Romanian authorities became suspicious of Russian territorial designs and began to look to the West for reliable partnerships.

19 Between 1918 and 1938, Romania was a liberal constitutional monarchy. In 1938, King Carol II abolished the Parliament, and ruled with the help of a close circle of elite (the so-called royal camarilla). In 1940, as a result of severe territorial losses, King Carol II was forced to abdicate and was replaced with his son King Mihai. However, power was grabbed by the military dictator Ion Antonescu until 1944 when King Mihai deposed the Antonescu regime.

20 The territory between the Prut and Dniester rivers.

21 The north-eastern tip of 'Greater Romania'; Cernauti (Chernovtsy) is the most important city in Bukovina.

22 As an extra security guarantee, Romania is also firmly committed to being part of the envisioned European security architecture (ESDP).

23 According to US law (American Servicemembers' Protection Act), "no United States military assistance may be provided to the government of a country that is party to the International Criminal Court." The law, however, permits the US president to issue two types of waivers: a first waiver is for those countries that sign an Article 98 agreement with the US government which prohibits the court from taking actions against Americans present in that signatory country; and a second waiver can be granted to NATO members (and other major non-NATO allies), as well as to other countries (on a case-by-case basis)

if the President considers it in the national interest to continue providing military assistance to a certain country. Romania has signed an Article 98 agreement with the US in 2002, and has joined NATO in 2004.

24 For the 1996-2004 period, supplemental funds were allocated in 2001 (Southeast European Initiative), and in 2003 (Operation Enduring Freedom Supplemental).

25 Through FMF, Romania received approximately \$70 million between 1996 and 2004. Through IMET, Romania received approximately \$10 million between 1996 and 2004. Source: Congressional Budget Justification for Foreign Assistance, FY 1996-2004.

26 Tables 1 and 2 list only the *main* security assistance programs for Romania; tables do not include allocations from: Excess Defense Articles; Additional Appropriations for Key Cooperating Countries for Logistical, Military and Other Support Provided to US Military Operations; Reimbursement of Certain Coalition Nations for Support Provided to US Military Operations; Commercial Defense Trade; Assistance for Eastern Europe and the Baltic States; or OSCE Peacekeeping Operations. For example, in FY 2005, the Department of State authorized the export of defense articles and services valued at \$ 77,554,794 for Romania. In FY 2007, Romania will be eligible to receive grant Excess Defense Articles (EDA) under Section 516 of the Foreign Assistance Act. FY 2007 NADR-funded Export Control and Related Border Security (EXBS) funding will be provided to Romania on an ad-hoc basis, with an emphasis on improving enforcement, licensing, and industry outreach capabilities. Sources: Congressional Budget Justification for Foreign Assistance 2005, 2006; Foreign Operations, Export Financing and Related Programs Appropriation Act, 2006; Foreign Assistance Act, 2006.

27 Figures for 2007 are estimates.

28 Source: Congressional Budget Justification for Foreign Assistance, 2006.

29 The agencies within the Ministry of National Defense in charge of administering the funds included in the US security assistance for Romania are: the Department of Armaments for FMF and FMS; and, the Human Resources Management Directorate for IMET Programs.

30 Child Survival and Health Programs.

31 Non-Proliferation, Anti-Terrorism, Demining and Related Programs

32 Support for East European Democracy Assistance. In view of Romania's accession to the European Union in 2007 (or 2008), Romania will be graduating from SEED in FY 2006. However, completion of SEED-funded programs will continue until 2008. For instance, Bucharest-based Southeastern Europe Cooperation Initiative (SECI) Anti-Crime Center, which coordinates regional criminal task forces working to combat arms, drugs and human trafficking, will continue to benefit from SEED funding in FY 2007 through the SEED regional budget.

33 Congressional Budget Justification for Foreign Operations, 2007.

34 Ibid.

35 The majority of all FMF funds (approx. 85%) goes to Near Eastern countries.

36 Congressional Budget Justification for Foreign Operations, 2007, including *infra*.

37 For instance, Maritime Training for SOF.

38 Congressional Budget Justification for Foreign Operations, 2007, including *infra*.

39 The *DISAM Journal*, Fall 2005, p. 128

40 The US ODC in Bucharest plays an instrumental role in forging a complex defense relationship between Romania and the United States. ODC activities are aimed at developing modern Romanian military capabilities that are professional, rapidly deployable, affordable and interoperable with US and NATO troops.

41 Seminars on how to effectively manage a training program established through FMF, FMS and IMET.

42 The large number of students trained (compared to Bulgaria and Hungary) is also due to the structural necessity to train as many students as possible with available funds – Romania still benefits from a large number of army personnel who need extensive training in order for the Romanian military to successfully achieve US and NATO interoperability.

43 Source for Tables 3, 4 and 5: Congressional Budget Justification for Foreign Operations, 2007.

44 These are just principled guidelines rather than specific operational and technical recommendations. For a detailed insight into the technical specificities of the proposed direction of US security assistance to Romania, please see Major Schumann's study, *A transformational approach to US security assistance – the case of Romania*.

45 *Quadrennial Defense Review Report (QDRR)*, 2006, p. 30.

46 QDDR, p. 89.

47 *The National Defense Strategy of the United States of America (NDS)*, 2005, p.15.

48 The list of the policy recommendations regarding US security assistance to Romania is not exhaustive, but it is meant to be illustrative of some possible policy directions.

49 *Romania's National Security Strategy*, 2005, p. 30.

50 Document on the Reform of the Romanian Armed Forces, retrieved from <http://www.mapn.ro> (accessed June 15, 2006).

51 According to Romanian government's projected industrial policies for the 2005-2008 period, the national strategy in the defense industry domain includes the privatization of the national defense industry, and the domestic development of modern military capabilities.

52 The procurement of F-16 Fighting Falcons, to replace some MiG obsolete fighters, should be an important part of the modernization process.

53 The Romanian armament industry is mainly composed of the following companies: *Romaero* (large aircraft repair specialist and aerostructure manufacturer); *Romarm* (major exporter of defense techniques); *Romtehnica* (import-export operator); *MFA* (privatized in 2003) – upgrade specialist for infantry and armored vehicles.

54 Especially upgrading the infantry vehicle MLI 84 M with the OWS 25R turret.

55 Kagan, F.W. 2006. 'The US Military's Manpower Crisis'. *Foreign Affairs* July/August: 107.

56 Military education cooperation could include dynamic contacts at the level of students and faculty between US Army schools, such as the US Army War College, United States Military Academy, National War College, Naval War College, Air War College, and counterpart Romanian military education institutions, such as the National Defense University, Military Technical Academy, Land Forces Academy, Naval Forces Academy, Air Forces Academy.

57 Supplemental US security assistance funds could be directed towards the Office of Defense Cooperation in Bucharest (ODC) which would conduct frequent seminars on procuring and maintaining US defense articles and services.

58 The RNTC could also offer fruitful premises for a comprehensive collaboration with the Anti –Terrorism NATO Center in Istanbul, Turkey.





## **A Transformational Approach to Security Assistance: The Case of Romania**

**Major Drew L. Schumann—US Army Reserve**

### **Introduction**

The future possibility exists the United States will find itself in a major conflict in Central-East Asia and/or the Middle East and will be unable to call upon traditional Western European allies or Russia for assistance. To protect against having to wage unilateral wars, with the resultant lack of power projection platforms near that theater, it is crucial that the US seek a close relationship with Eastern European nations through security assistance. Security assistance represents a diplomatic, military and economic tool for fostering strategic partnerships.

The United States should not deal with Eastern European nations as a homogenous “bloc”. Each Eastern European nation has individual interests and theories of diplomacy, as well as national pride and industrial policies. It is necessary to pursue policies bilaterally. It would make sense to approach individual Eastern European nations and provide security assistance that would help with their long- and intermediate-term needs, all the while steering Eastern European nations to common military equipment and doctrinal architecture for their long-term security needs.

Eastern European nations in general, and Romania in particular, are strategically important primarily due to geography and political opportunity. They are important geographically, because they are located closer to Central-East Asia and the Middle East, and serve as a buffer zone against military action from the east, as well as serving as a spring-board for power- and force-projection towards those areas. In terms of political opportunity, as Eastern European nations recover from the depredations of communist rule, security assistance can set the stage for alliances, much like the Marshall Plan set the stage for the development of NATO.

Each Eastern European nation can be approached to provide a military role which they can execute with excellence. At no point can the US afford to treat its new allies as second class citizens or “auxiliary” troops. With new technologies that de-emphasize the importance of massive forces, highly-trained, relatively small units can have a profound impact on the modern battlefield. Romania affords an example and a case study of how such policy might work in practice.

Currently, pursuing a single nation, like Romania, in a bilateral engagement, could be used as a template for developing security assistance to other Eastern European nations. The concept is that once Romanian security forces demonstrate the feasibility of such an approach, other nations would be motivated to follow. Romania is a good example regarding a new transformational approach to security assistance, because they are a nation in flux, with a history of technological innovation and are historically good allies to great powers. Romania is also small enough, so that it is possible to make a big impact on their security situation with relatively fewer dollars.

Each nation's security needs and diplomatic theory could be satisfied, plus they could decide what niche they would fill in the international security arrangement. Short-term, US security assistance could be used to develop the underpinnings of both economic and military security issues. In addition to short-term needs of the various nations being satisfied, Eastern European nations should be steered toward cooperation in developing military equipment, doctrine and tactics. For Eastern European nations to be able to afford the level of technologically advanced equipment necessary to compete on the modern battlefield without "breaking the bank" economically, cooperation will be vital.

In order for new military equipment to be affordable, attention must be given to ensuring that as many new military designs as possible be developed locally and have valid civilian applications allowing for commercial use and export. Technologically advanced military equipment is fundamentally suited for dual applications in contrast with older style weapons systems.

It is also critical that US security assistance not take the form of "giveaways." Politically, unilateral support of other countries is becoming more and more unpopular within the US. Creative ways are necessary to provide assistance which has direct and visible benefits to US interests. The fundamental justification for security assistance to Romania should be tied to a Romanian National Training Center (RNTC); the maintenance of US training equipment; and Romanian forces with their unique equipment to train as a professional Opposing Force (OPFOR).

Money which goes to Romanian industry in order to develop modern military equipment can be justified in that it results in a better trained US Army through the unique training experience provided at the RNTC. The strength of the US National Training Center is that the US OPFOR is the best trained military unit in the world. The weakness of the NTC, is that the OPFOR equipment is outmoded, and difficult to maintain. Assigning OPFOR duties in Romania to Romanians results in a high payoff, transformational mode of operation. First, doing so provides US security

assistance to an enthusiastic ally without making it a “giveaway.” Second, US military units benefit from realistic training. Third, Romanian units get to “train for war” at an extremely high Operational Tempo (OPTEMPO). Fourth, new tactics, doctrine and equipment can be developed for both US and Romanian forces in a crucible much more diverse than the traditional NTC “Red Horde” scenario.

A Romanian NTC can be a much more flexible operation that can provide a multi-faceted tactical situation. While Romanian forces can be used to portray traditional tactics, mimicking various nation-states viewed as threats to US interests, they can also provide a much more creative, asymmetrical threat, to include live Aerial Port of Debarkation (APOD) and Sea Port of Debarkation (SPOD) to maneuver area scenarios. US forces would be able to test their ability to establish a beach-head, seize an airfield, and fight in urban, suburban and in open terrain. None of the existing Combat Training Centers (CTCs) have the continuity that a Romanian NTC could have. In fact, the proposed “RNTC” would have very little “notional” play during a maneuver force rotation.

As mentioned earlier, Romania would be a good candidate for this transformational concept of security assistance, because of their history of technological innovation. Therefore, it is useful to examine the history of Romanian military production capability and innovation. Romanian historical military technology production and more importantly, innovation, points to the potential in Romania that could be tapped by an unconventional form of security assistance by the US.

### **Armor**

Romanian arms producers have a long and distinguished history of “doing more with less” when developing and producing armored vehicles. While they have never produced a completely native Romanian design, they have enthusiastically adopted obsolete/obsolescent designs from other countries and through innovation, made those designs relevant again. In World War II, while allied with Nazi Germany, Romanian arms manufacturers received obsolete Armored Fighting Vehicles (AFVs) from some of the recently conquered territories. Examples include the R-2, which was based on captured Czech 35(t) tanks. Romanian producers simply up-gunned the tank with a 45mm Anti-Tank (AT) gun.

Romanian innovations really showed promise with the conversion of Soviet light tank T-60, when they upgraded it to a 76.2mm assault gun, and renamed it the TACAM T-60, or T-1. The Romanians also had some Czech 35(t) tanks which they also converted to assault guns based on the Soviet 76.2mm guns, captured by the Germans. These vehicles were renamed the TACAM R-2.

The culmination of WWII Romanian tank innovation, though, was a revolutionary armored fighting vehicle, which was based on the Soviet T-60 light tank chassis. The Romanian engineers combined a lengthened T-60 chassis, a more reliable Hotchkiss H-39 tank engine, a high velocity German 75mm gun or Soviet 122mm gun in the lowest possible profile vehicle and named it the “Maresal.” This Romanian produced vehicle became the impetus for the German “Hetzer” and was produced in various forms throughout and after WWII.

The next—most relevant to today’s situation—innovation occurred when the Romanians breathed new life into the venerable T54/55, creating an almost new design called the TR-85. While the T-54/55 is a fairly competent tank, roomy and fightable by Soviet standards, it lacked the cross-country mobility demanded in Romanian mountainous terrain. Romanian engineers solved this problem by lengthening the T-54/55 chassis, adding another set of road wheels, and doing away with the Christie suspension and replacing it with a bogie supported suspension.

Recently, Romanian engineers, in cooperation with France, Britain and Israel, have improved the TR85, with a TR85M1 variant. Improvements include a better engine and transmission, better armor, (ERA and composite) thermal sights, modern fire control system, and an improved projectile for the 100mm gun. Romania possessed around 300 TR85s at the start of modernization and NATO inclusion around 1997, and hopes to convert enough TR85s to the M1 variant to field two Brigades.

In the development of the TR85M1, Romania faced a quandary. They had approximately 30 TR125s, which are basically T72s with lengthened chassis. Contemporary armor technology in most countries had been and is focused on bigger, more powerful guns and bigger, more powerful tanks, so Romania made a counter-intuitive decision. The TR85 had certain characteristics which made it superior to more modern Russian and Ukrainian designed tanks. Specifically, the turret is roomier, which allows for upgrades “under armor.” It has better ergonomics and survivability with improved and additional ammunition storage. The main gun has better depression characteristics, which is essential in fighting in broken terrain. The lack of an autoloader and ammunition carousel allows for quicker reloads, better crew/tank survivability and provides an additional crew member for fighting dismounted infantry and maintenance. In addition to the better turret design, the lengthened chassis and additional road wheels give the TR85 superior off-road capabilities from the other T-series Soviet/Russian/Ukrainian designs.

The TR85M1 is ideally suited for war plans which include the withdrawal of military forces to the mountainous interior of Romania. It provides armored fight-

ing capability that is not equal or superior to its neighbors, but is appropriate to the defensive mission and terrain most likely to be used in defense of Romania. The improvements to the fire control system and 100mm projectile are adequate to the task, rather than over-matching. Most importantly, the TR85M1 conversion is affordable, and currently, affordability is the most critical component of Romanian defense.

At the time of the Romanian anti-communist revolution, the Romanian military used two primary infantry fighting vehicles (IFVs). The primary tracked IFV was designated MLI-84, and was a modified version of the BMP-1. The main modification was the inclusion of a 7.62mm machine gun facing aft from the rear crew compartment. Since 1994, Romania has partnered with the US, Israel, UK and France in upgrading the MLI-84, and in fact, almost making it a completely different vehicle. Upgrades included removing the 73mm low velocity gun and replacing it with an Israeli designed and built *Rafael* Overhead Weapons System (OWS) which incorporates thermal sights, full stabilization and a 25mm *Oerlikon* high velocity cannon with dual feed capability. This modification alone makes the MLI-84M an extremely lethal AFV.

In addition to the OWS 25 R, the MLI-84M received a missile upgrade, with greatly improved versions of the AT-3 Malyutka or *Rafael* SPIKE missiles which are attached to the OWS. The MLI-84M improvements also include a new power pack and transmission. Romanians claim that the armor protection is improved, but no external indications point to ERA or appliqué armor, and the MLI-84M retains the problematic firing ports, which weaken the side armor.

One category in which the Romanian military capabilities could be upgraded, would be in that of the Heavy Armored Personnel Carrier (HAPC). The Israelis, Germans and Russians are converting obsolete tank chassis into HAPCs, due to the weaknesses inherent in traditional lightly armored IFVs like the MLI-84M. The current world threat situation has shown that the HAPC has unique survivability aspects. The Israelis led the way with the conversion of T-55s into the Achzarit and the Russians followed closely with the BTR-T. Romania has large stocks of T-55s, and could adapt them into HAPCs at a reasonable cost.

## **Artillery**

According to Ministerul Apararii Nationale, the Romanian Ministry of Defense, Romania has taken the unusual step of completely eschewing conventional tube launched artillery. They have adopted an “all-missile” force, centered on the

jointly produced 160mm LAROM system. The system combines Romania BM-21 chassis and lift mechanism with the Israeli 160mm LAROM missile.

While the Romanian LAROM shoots the modern LAROM missile and has improved communications and targeting, with “en bloc” containerized supply and re-loading capability, it can still shoot original 122mm Warsaw Pact missiles without extensive modification, increasing its usefulness in austere theaters of operation. The 160mm LAROM rockets have a 45 km (30 miles) range.

### **Infantry Weapons**

Until recently, Romanian infantry weapons have been both a profit-center and a problem for Romanian industry. Upon the formation of the Warsaw Pact, Romania, like most other Eastern European countries, adopted Soviet-designed weapons, but manufactured them locally, and even made several improvements on Soviet designs. In particular, Romania took design features from the AK-47 rifle, the RPK squad machine gun, and the Dragunov sniper rifle, and produced an elegant and effective marksman rifle known as the PSL. The PSL addresses the accuracy problems of the AK-47 and the complexity/reliability problems of the Dragunov, which resulted in a synergistic effect, producing one of the better rifles of the latter 20th century. *RATMIL*, the current producer of the PSL, is currently producing rifles in 7.62x51mm NATO for sale to American shooters as well as possible use as NATO standard weapons.

Romanian infantry weapons are also proving to be a bone of political contention. The much publicized UN-OSCE identified Romania, in 1995 as being a major player in the small-arms proliferation. Since that time, Romania has signed on to most major small arms non-proliferation agreements and is publicly compliant with those agreements.<sup>1</sup> However, that does not stop them from selling to the US and other countries where firearm purchase and possession is legal, several different varieties of excellent military-style firearms. Romanian small arms industry retains a very competent small arms production capability

### **Aviation**

One of the brightest parts of Romanian military design and manufacturing is in the aviation field. Romanian security concerns have resulted in a distinguished history of producing superior quality aircraft that have world class capabilities. Starting in 1916, Romania produced license-built Nieuport 11, 12 and 17 aircraft. Between World War I and World II, Romania produced under license or purchased a mixture of French, Italian, Polish, German and British aircraft. While Romanian

production aircraft have had mixed results, the IAR 80, a completely original design, proved to be “state of the art” during the earlier stages of the World War II. The IAR 80 proved that given creativity and experience, it did not take a great power to produce a capable combat aircraft.

It was not until 1968 that Romania returned to the production of modern aircraft. They designed, but did not produce a business aircraft, the IAR 90, and two supersonic fighters, the IAR 91 and 92. Then, in the mid-70s, Romania partnered with Yugoslavia to produce a trans-sonic attack aircraft known as the IAR-93 “Yurom” in Romania and the J-22 “Orao” in Yugoslavia. While Serbia still uses the J-22, the last IAR-93 was grounded in 1992 in Romania<sup>2</sup>

In the late 70s, Romania developed a supersonic fighter, which was officially cancelled in 1988 due to an austerity program. This fighter was designated the IAR-95 “Spey.” It is instructive to note that Romania, while a very small country with somewhat limited financial potential, is still capable of designing a sophisticated supersonic multi-role aircraft.

The IAR-99 “Soim” (Hawk) became the most successful Romanian designed and built aircraft after World War II. Initially developed in the late-70s, the IAR 99 is a trainer/light attack aircraft. Recently, the IAR-99 has undergone an upgrade, which includes sophisticated avionics, targeting and counter-measures electronics which makes it functionally identical to most state-of-the-art multi-role aircraft in the world today. While these features make it a brilliant trainer, it also makes it an extremely competent light attack aircraft

After the collapse of the Soviet Union, Romania was faced with a choice, similar to the T-72 versus TR85 dilemma. Romania had a mixture of MiG-29, -23 and -21 aircraft. Conventional wisdom would have favored the MiG-29 as the superior modern front-line fighter, but Romanian Air Force officials looked carefully at the cost versus performance, plus the unreliability of obtaining spares from the former Soviet Union, and decided to retain the MiG-21 and ground the -29. Romania sought a partnership with the Israeli firm *Elbit* which assisted Romanian authorities in developing an upgrade package which has turned the MiG-21 into the MiG-21 Lancer. The Lancer upgrades turn the aging MiG-21 into a modern, all-weather multi-role fighter that is affordable and capable. The targeting and telemetry packages in the Lancer are identical to the IAR-99, so pilot training leads to a fairly seamless transition from advanced trainer to multi-role fighter.

Romanian aviation is one of the potential industrial profit centers. Under the theme of making the military more affordable, Romanian aviation companies are

producing both military and civilian aircraft on the same assembly lines. Aerostar SA of Brasov, location of the original IAR company prior to the end of WWII, produces a wildly popular (at least in the US) aircraft called the Yak-52. While it was originally designed by the Russian company *Yakovlev*, it is now produced only in Romania and provides the complete antique “warbird” feel in a small and affordable package. Incidentally, Romania uses the Iak-52 as their primary pilot training aircraft.

Because of their experience with the lucrative American sport aircraft market, Romanian companies have started aggressively marketing both Romanian designed and built aircraft, and are producing sub-components and kits for American owned and produced aircraft factories. Romanian aircraft for sale in the US civilian market include the F99 and Festivale F40, also *Aerostar SA* is producing major subcomponents for the Florida-based Liberty XL2 certified private aircraft.

Romania produces its own rotary-winged military aircraft, primarily a license built copy of the Puma, known as the IAR-330. They produce utility, command and control, naval warfare, and medevac versions, and have developed, in conjunction with the US, Israel, UK, France and Italy, an attack version of the IAR-330. The upgrade system, known as SOCAT, is a NATO interoperable Anti-Tank Search and Combat system which gives the venerable Puma a new mission.<sup>3</sup>

Somewhat disappointingly, Romania has chosen to purchase, rather than develop a battlefield Unmanned Aerial Vehicle (UAV). Small UAVs have been developed, though not fielded by Romanian forces. The Shadow 600 UAV was purchased from the US-based AAI, Inc. The Shadow 600 is a fairly capable, medium to small-sized UAV with good duration and adequate payload.<sup>4</sup> Provided that most components for UAV production are available “off-the-shelf” and can be purchased and assembled by wealthy individuals, much less nation-states, it is somewhat surprising as to why Romania purchased such a system. The extent and skill of the Romanian aviation industry would suggest that locally-produced UAVs and possibly Unmanned Combat Aerial Vehicles (UCAV) production are realistic goals.

While Romania still uses the Antonov-2, -24 and -26 transport aircraft, in 1996, the Romanian Air Force procured several C-130B aircraft, for use as operational/strategic air transport of troops, equipment and supplies. More importantly, the use of C-130s has forced Romania to become fully NATO compliant in its military airfields.



## **Naval**

In January of 2003, Romania purchased two Mk 22 British Frigates, had them upgraded in British yards, and commissioned them the Regele Ferdinand and the Regina Maria (King Ferdinand and Queen Mary). Currently, there is great controversy surrounding this purchase, conversion and commissioning, as certain individuals involved in the purchase of these ships may have received improper financial incentives from *British Aerospace* (BAE.) Also, the purchase price is being examined as to comparative and proper value of these two ships. Nonetheless, two Mk 22 frigates, combined with the four Romanian frigates and the single “Marasesti” class destroyer, makes Romania a force to be reckoned with on the Black Sea.

## **Air Defense Artillery**

Germany, in November 2004, assisted Romania’s efforts to become NATO-compliant, by donating 43 surplus Gepard self-propelled anti-aircraft guns. The donation of such modern and reliable anti-aircraft systems is nothing to scoff. However, one wonders what the future maintenance status of these unique systems will be. The Gepard is based on the Leopard I tank chassis, and these 43 vehicles are now “orphan systems” within the Romanian Army. Perhaps, once the surplus Leopard I parts became expensive and difficult to acquire, the Romanian Army can look to placing the turrets on T-55 or TR85 chassis. Partly because of the generous nature of the Germans, Romania has adopted the 35mm Oerlikon anti-aircraft gun as Romanian standard.

In another attempt to “make-do,” Romanian arms makers have combined the 35mm guns from the Gepard with the former Soviet ZU 23-2 towed AAA system. This system, despite its dated appearance, is actually a sophisticated system, which best of all is airmobile, easily concealable, has day/night capabilities and is interoperable with NATO forces, including IFF functions. The 2x35mm system also is dual use, with excellent anti-armor capability.

The US has partnered with Romania in the modernization and development of the HAWK XXI system as a medium range anti-aircraft solution. This will ensure interoperability with NATO systems and will integrate with Seamless Converged Communication Across Networks (SCCAN), which Romania purchased from Canada. Under the sales agreement, Romania will develop its own logistic support capabilities for the HAWK XXI system to ensure continued high operational rate service.

The US has also sold the Medium and Low Altitude Radar “Gap Filler” to Romania, which ties the National Air Command and Control System from the HAWK XXI medium range AA missile system, to the Gepard and 2x35mm towed system, which are short range. Therefore, combined with the longer range capabilities of the SA-6 and SA-8 systems already possessed by the Romanian military, Romania will be able to deal with almost all air threats from high altitudes down to the ground, with excellent Identification, Friend or Foe (IFF) and air control.

### Communications

Closely linked with the concept of Air Command and Control, the Romanian military has purchased the STAR system of tactical communications system. A consortium of the UK Thales Defense and Harris Systems, STAR is a digital, frequency hopping, secure, data uplink which will be compatible with most Command, Control, Communications, Computers, and Intelligence (C4I) systems which will allow future Romanian forces to be fully networked. As current operations in the Middle East have shown, C4I capability and networked combat vehicles and soldiers will be a key element in any effective future force, and should be a goal of Romania and those who wish to offer her security assistance.

### Romania’s military/technical partners

Prior to proposing areas for security assistance to Romania, one needs to look at what assistance and technical partners Romania already has. Romanian authorities have been rather omnivorous in their selection of partners, with special emphasis on the US, Israel, UK, and France. The US has been, and remains, the focus of Romanian military partnership, and US/Romanian interoperability exercises have been on-going since the mid- to late-nineties. Romania has a good cultural and military basis for expanding its unique bilateral relationship with the US in the future. Here is a list of Romania’s military/technical partnerships:

Country	Military Equipment
US	MLI-84M, UAV Shadow 600, IAR-99, IAR-330, HAWK XXI, Gap Filler, NACCS, TGASFAN, STAR radio
Israel	MLI-84M, LAROM, IAR-99, IAR-330
United Kingdom	MLI-84M, IAR-330, TGASFAN, Type 22 Frigate, STAR radio
France	TR85M1, MLI-84M, IAR-330, IFF, TGASFAN
Germany	Gepard
Italy	IAR-99, TGASFAN, RTP/STAR
Switzerland	MLI-84M, 35mm AAA
Finland	LAROM
Canada	TGASFAN
Norway	TGASFAN

## **Proposed areas for security assistance to Romania**

Going forward, there are several areas where the US could make a positive impact on Romanian security needs. These areas could, if approached adeptly, have a positive impact on US long-term security needs.

### **Industry enhancement**

First, Romanian industry needs enhancement among all things. While the fundamental economic foundations of Romania are superior to most of their East European neighbors, Romania is still behind western countries in development. It is Romanian policy, as well as in the long-term best interest of the US, to encourage Romanian weapons development rather than donations of obsolete/obsolescent equipment. As Romanian history shows that as soon as they develop an excellent military system they promptly sell it to pay for their own military consumption, it is key that US aid be focused on “dual use” technology and manufacturing.

Dual-use goods are those that, while militarily useful, can be sold as civilian goods. Also, factories which produce military goods can be set up to produce similar civilian goods if set up properly. A good case in point is the Liberty XL2 light aircraft. The Liberty XL2 is an all-composite US design, and Aerostar SA of Brasov, produces Wings and Tail surfaces and exports to Liberty in Florida. The production line is set up parallel to the Aerostar MiG 21 Lancer conversion line, as well as the Iak-52 assembly line and the jigs can be easily repositioned and broken down to make space for production of different types of aircraft and sub-components. In addition to the physical assembly line construction, the composite construction of the Liberty XL2 could be used for drone, advanced combat aircraft, as well as “stealth” technology production.

Burt Rutan/Scaled Composites (of Voyager and SpaceShipOne fame) has shown that a practical multirole aircraft can be built off the airframe of an executive jet and vice-versa, with their ARES light attack aircraft along with several different light corporate jet designs. As security assistance can also be defined as economic security, dual-use manufacturing capability should be a feature of US security assistance to Romania as well as to other key countries.

### **C4I**

The Romanian military has, up to this time, properly focused on modernizing its communications equipment and is seeking C4I capability. In future conflicts, the ability of Romanian troops to communicate along all spectrums of the communications battle-space will determine what level of assistance they will be able to

give us. It is, therefore, in the US' best interests to see to it that Romanian military units can communicate and be compatible with the state of the art US C4I system. To this end Romanian communications industry should be cultured and developed. It would be good from a national pride; sustainability and security standpoints to have the ability to produce maintain and repair C4I equipment domestically. Romania has the internal ability to produce microchips. Romania should be encouraged to produce truly high tech automation systems that apply to both civilian and military applications.

### **Training**

On the modern battlefield, equipment and communication quality are extremely important, but training realism and intensity are crucial. National Training Center-type force on force, intensive training is the best currently possible, given the state of simulators. Romania has several large training areas which would be appropriate to a Combat Training Center (CTC) environment. It has been said that the best units in the US military are the OPFOR units which portray projected threat forces for military units rotating through the Joint Multi-National Training Center at Hohenfels, Germany, the Joint Readiness Training Center at Fort Polk, Louisiana and the National Training Center at Fort Irwin.

A creative proposal would involve Romanian units rotating OPFOR duties in a CTC located in Romania. The CTC could be primarily financed and used by the US, but would remain available for other allied countries to use to train their military forces. A Romanian OPFOR could offer various levels of "play:" Scenarios could vary from scripted and controlled to "free-for-all" with variations in-between based on the training level of the trainee units. Romanian OPFOR units would use their own "go to war" vehicles, providing a dissimilar threat for training units, and the OPFOR mission would provide additional training and a proving ground for tactics development on both the Romanian and US side.

Regardless of the means, US assistance should pay special attention to the amount and quality of training. Romanian forces are already doing limited training exercises with NATO forces. Historically, Romanian military training has been very Spartan, with limited ammunition, fuel and training areas available. According to veterans interviewed by this author, almost half of Romanian soldiers prior to the current cuts in manpower and focus on an all-volunteer, professional army, were involved in farm work to support local communities and military units.

## **Aircraft**

While the MiG-21 Lancer upgrade was a smart, interim move, Romania will continue to have a need for a modern, multi-role fighter. As Romania shares this need with other Eastern European countries, it would be desirable from an interoperability and alliance aspect to encourage those countries to develop their own modern multi-role fighter. Security assistance money could be tied to cooperation, with dollars for one subcomponent going to one country, while another subcomponent can go to another.

Romania could also be encouraged to develop a fleet of light attack aircraft and possibly a UAV/UCAV with a business jet sister that could be produced on the same assembly line. This aircraft could be directly- or remotely piloted.

## **Armored Vehicles**

The Romanian “Zimbru” version of the BTR 60 is doing excellent work in Iraq and Afghanistan. Wheeled armored vehicles have shown excellent value in the current threat environment. The “Zimbru” would benefit from being up-armored for Mine/RPG/ATGM resistance. It would be useful to replace the 14.5mm gun with a new gun, acquisition and targeting system, possibly OWS 25mm so that it would be fully compatible with the MLI-84M

While the TR85M1 is sufficient for Romanian home defense, if Romania wishes to remain competitive for future international cooperative military operations, they need to have an AFV that can be moved easily to future theaters of operation. Areas bordering the Black Sea will be accessible by sealift, but the Future Romanian Armored Fighting Vehicle needs to be light enough for airlift, mobile enough for mountain warfare/recon, survivable, probably capable of carrying dismounted infantry, possess a common chassis for logistics simplicity, sufficiently lethal and be linked through C4I. Perhaps a future effort can be forged in cooperation with other Eastern European nations, with assistance dollars directly linked to international cooperation.

## **Political Ramifications**

There are several political considerations which accompany security assistance to Romania. First, Romania has traditionally had a certain amount of enmity with Hungary, though the current situation, where Romania must behave to obtain the benefits which come with EU and NATO membership addresses this conflict nicely. Tying security assistance directly to behavior has and will prove effec-

tive. In addition, cooperative development and production of military and civilian goods will help to address the insular nature of Romania.

Fundamentally, while Romania has some challenges, entering the western world in the 21st century, the country is small enough for assistance dollars to make a genuine difference. Combined with their lack of debt, high employment, and tradition of acting as a loyal ally, Romanian weapons development skill makes them a terrific candidate for experimentation with alternative means of assistance.

Security assistance focused on Romania would not be an end to itself: Romania is a small country, and will have to specialize to be relevant. Other East European countries can each take a piece of the security pie and contribute in accordance with their national character. Bottom line: US goal should be to provide security assistance to all East European nations that show promise, partly as a foil to threats from the East, but also to have a plan “B” should traditional European allies prove undependable in future security scenarios. This security assistance should percolate up through East European industry, and be dependant on how those countries see their own security needs and ability to contribute.

### **Endnotes**

1 Statement by H.E. Mrs. Anda Filip, Ambassador, Permanent Representative of Romania to the Conference on Disarmament *Geneva, June 19, 2003*

2 *The IAR-93 Saga* by Danut Vlad, The Romanian Air Force Connection, <http://www.deltawing.go.ro/iar93saga.htm>,

3 *Upgrading Programs*, Romtehnica, [http://www.romtehnica.com.ro/upgrade/up\\_iar\\_puma.htm](http://www.romtehnica.com.ro/upgrade/up_iar_puma.htm)

4 AAI Inc. Corporate website, <http://www.aaicorp.com/defense/uav/600.html>, 2004

## **Why is There No Anti-Americanism in Romania Today? A Cultural Perspective On Security Assistance: The Case of Romania**

**Mr. Silviu Hariton—Central European University**

### **Introduction**

In the last decade, anti-Americanism seems to become more virulent than ever all over the world, grouping under the same umbrella a large palette of feelings like being anti-Western, anti-globalization and anti-capitalism, anti-George W. Bush etc. What was a peculiarity of the French leftist intellectuals financed by Soviet Union immediately after the end of the Second World War and rather isolated at the global level in terms of impact and sincerity, has been spread to the Latin American intelligentsia in the 1960s, and later to the Black African countries and the Arab world. To a certain extent, on all continents there are groups of people frustrated that at this point United States is the only superpower (in the terms of a conventional war), their frustration manifesting in blaming US for over acting if the US had decided to act on a matter or another, and/or blaming US for not taking action or being indifferent whenever US is waiting for other international actors to take the initiative.

This sentiment of anti-Americanism mediates the reception and understanding of a large palette of actions of the American government in its relations with the allies as well as the attitude of the local population where the American troops are present (the bases from Europe and Pacific as well as Afghanistan and Iraq). Consequently, this sentiment may affect the long term efficiency of both the use of the security assistance provided by US to its allies and the assistance that some of these allies are able and/or desire to offer to the US. Real democratic regimes from Western Europe as well as countries from South-America and Africa has to take into account and shape some times their foreign policy according to this sentiment of anti-Americanism which dominates segments of their population/voters.

In this context, Romania is rather a unique case of a country where the feelings of anti-Americanism are rather isolated at the level of some individuals, and they are not manifested almost at all in the public space (mass-media, political discourses and programs, academia, different groups e.g. army, businessmen) as well as within the mass of the common people. By contrary, to a certain extent, most of the people seem to be rather indifferent in discussing the issues at stake in detail, being dominated by the feeling that ‘America (that we have waited for 50 years) knows better than us.’ Different social groups have different causes for their

filo-Americanism or at least lack of interest in the anti-American manifestations: “the American way of life” has represented a strong model for the common people in the 1990s. The technological advancement and the management efficiency of the Western countries in general, and of the United States in particular, was admired by the bureaucrats of all kind well before the implosion of the Communist system, while most of the intellectuals and some of the politicians have admired the model of democracy represented by the United States and the values offered by the democratic system: freedom of thinking and expression, freedom of association, enterprise and travel etc. Of course, one of the possible conclusions is that Romania as well as some of its neighbouring countries may represent a precious, trustful and very helpful ally for the US in the future as well as a good base for further action in Central Asia and Middle East.

The aims of this paper are to explain how is it possible this lack of interest in a theory of conspiracy according to which the US and the values propagated by it is at the origin of the most of the evils in this world, what are the long term developments and transformations of the cultural references that have set the collective memory and the collective identity of most of the Romanians and/or inhabitants of Romania, and what are the means to contain further spread and dissemination of anti-American feelings. In order to accomplish these aims, the first part of this paper deals with the problem of anti-Americanism in general and its relationship with the local conditions of manifestation. A second part argues for the lack of anti-Americanism in nowadays Romania. The third and most important part presents the long-, mid-term and immediate causes for this lack of receptivity of Romanians towards anti-US feelings. The fourth and last part reflects on the factors of westernization/americanization and their role in containing the spread of anti-Americanism as well as makes suggestions on the further policies towards Romania in the field of culture.

### **What is Anti-Americanism?**

Anti-Americanism has multiple facets today, some times depending on the context of reception. The best author on the topic is the French Jean-François Revel, whose book published for the first time in French in 2002 was also translated in English in 2003.<sup>1</sup> Revel is an old French liberal, in the European meaning, who is dealing with the French anti-Americanism in particular, and the European one in general. In his introduction, Revel stresses the Soviet post Second World War propaganda as the main source of the anti-American feeling and distinguishes between the leftist version from a rightist one. According to the leftist version, since the US was the leader of the “capitalist world” and since capitalism was the absolute evil for a true fighter for the liberty of the people, then anti-Americanism



was something rational, to be shared by any French educated person. This kind of anti-Americanism was also propagated in Romania, more virulent in the 1950s and 1960s but also present in the 1970s and 1980s (articles about racism, poverty of the common people vs fortune of the “capitalists,” the military-industrial complex etc.) It is a bit ironic that only after the defeat of communism its propaganda has spread so much... The rightist anti-Americanism has raised from the frustration provoked by the fact that the former European great powers (like UK, France, Germany) have lost the initiative and have become minor players in the international arena after the Second World War.<sup>2</sup>

Revel concentrates on the French type of anti-Americanism, manifested mainly under the form of the movement anti-globalization as well as the protest against American “unilateralism” in international politics. Wearing t-shirts with Che Guevara, most of the time being people with a respectable social status which mean they have time enough to participate in protest and do not have to work in order to earn their living, the anti-globalization activists are protesting against the policies promoted by the World Trade Organization insisting that the multinational companies (especially those based in the US) are the profiteers of the situation and free trade is helping only the “rich countries” to prosper. As a consequence, the local products should be protected against the foreign (French cheese and wine against McDonalds). Globalization is also seen as a form of uniformizing/americanizing the local cultural specificity. The protesters against American “unilateralism” are unsatisfied with the fact that United States has remained the only “super-power” after the collapse of the Soviet Union, their frustration manifesting in blaming US for over acting, acting alone, or not consulting the others if the US has decided to act on a matter or another, and/or blaming the US for not taking action or being indifferent whenever the US is waiting other international actors to take the initiative. A special way to anti-Americanism is anti-Bush-ism: people who were pro-american or at least indifferent to anti-Americanism has turned skeptical or even against the US after becoming anti-Bush.

However, one should not consider that feelings like anti-Western, anti-globalization, anti-capitalism, and anti-George W. Bush are simple facets of anti-Americanism. If in Western Europe, anti-Americanism is rather a form of anti-Westernism in Black Africa and the Arab world which dates back from the nineteenth century if not earlier. The processes of colonization (mainly UK and France) has lead to the occupation of most of Africa and Arab Asia, determining local social transformations (“modernization”) which were only partially and unequally implemented. After the decolonization, most of the populations of these new states have adopted a kind of rethoric according to which “West” was responsible for all their problems and “it” should always be available to repair the damages of the process

of colonization e.g. in Nigeria, the US is seen responsible for the problems of the country because 'in order to assure the extraction of oil' it is bribing the local authorities (as if the locals have to responsibility for asking and/or accepting bribing). Anti-Western feelings have existed long before anti-Americanism in Russia as well as in the Ottoman Empire, and only politics of social development in the respective areas have contributed to the lowering of the level of anti-Westernism.

From a methodological point of view, in order to understand the dissemination of the sentiment of anti-Americanism, one should pay attention to the importance of social stratification. The dynamics of the social groups which are or may be the most important carriers of anti-Americanism. For example the intellectuals in France, the mass-media in Western Europe, the politicians in Latin America, the clergy in the Arab world as well as the opinion of the common people.

### **No Anti-Americanism in Romania?**

This second part of the paper reviews the political development of post-Communist Romania, concentrating on a series of events in the US-Romanian relationships which supports my assertion about the lack of anti-Americanism within the population of Romania today or at least within its most active and/or vocal part.

The Romanian sympathy towards the United States may not be understood without referring to the problems of Communist legacy in post-Communism, a legacy reflected mainly in the mentalities of the people educated during the communist infrastructure. During the 1990s two main political trends battled in the Romanian political arena: the pro-Communist, anti-Western and non-reformist trend lead by the Democratic Front of National Salvation FDSN (later Party of Socialist Democracy PDSR and after 2001 Social-Democrat Party PSD), which was ruled by Ion Iliescu, a former reform-minded Communist who was marginalised by Nicolae Ceausescu in 1971 and who was the only leader of Eastern Europe to sign a treaty with Soviet Union one month before its breakdown. The other trend was the anti-Communist and pro-reform and pro-West trend lead by Democratic Convention from Romania CDR, representing a coalition of parties including the Christian-Democrats PNTCD, the Liberals PNL and other minor parties and NGOs.

FDSN had ruled Romania until 1996 with the support of a series of extremist parties like Greater Romania Party (PRM), Party for National Unity of the Romanians, and the Socialist Party—its main concern being the conservation of the Communist social and economic legacy while a rethoric of nationalism has dominated its discourse (including mistrust towards the foreigners, especially the Hungarians and the Westerners—a legacy of Communist rhetoric). Against this

background, CDR started to become more popular and eventually win the elections of 1996 and form a very heterogeneous coalition with the Democratic Party and the Democratic Union of Hungarians from Romania. This coalition had started in 1997 a reform program which was already implemented in the other Central European countries – the Visegrad group (Hungary, Poland and Czech Republic), tried to get the invitation to join NATO in 1997 (which was addressed only to the Visegrad group) but managed to start the negotiation process aimed to allow Romania join the European Union.

This process of reform was continued in a softer but much better organized way by the Social Democrat Party (the former FDSN and PDSR), now lead by Adrian Nastase as a prime-minister (2000-2004) while Ion Iliescu remained a passive president of Romania,<sup>3</sup> their greatest realizations being the opening of the Schengen space frontier to Romanians, the 2002 invitation of Romania to join NATO in 2004, and the treaty of Romania's adhesion to European Union in 2007 or 2008. Nowadays, a coalition of Liberals, Democrats and Hungarian minority's party is preparing Romania to finally join the European Union.

This excursion was necessary to explain the low level of anti-Americanism which was felt during a series of events in the American-Romanian relationships. One should understand that the most important social and cultural cleavage was clustered during the 1990s around the problem of "reform," most of the urban and young population being oriented as pro-reform, anti-Communist, and especially pro-West, seen as THE model opposed to a Communist system unable to reform itself.

No "hellcome" was organized for John Paul II (the first and single visit of the Pope to an Orthodox country) and Bill Clinton in 1997 (who came after Romania was invited to join NATO) or for George W. Bush in November 2002. All the politicians, mass-media and intellectuals had positive reactions, seeing these events as signs of the improvement of the country's situation and promises for a better future.

A turning point was represented by the NATO bombardment of Serbia in 1999.<sup>4</sup>

If in 1997, a large majority of the Romanians was sympathizing NATO, in 1999 the situation was the complete opposite. Pro-Orthodox/Serbian and anti-West rhetoric (but without a concentration on US) were inflated by the opposition PDSR which saw the occasion to profit from the majority of population's dissatisfaction with the badly managed economic reform of the CDR led government coalition.

About the consequences of the war on the Romanian economy, Catherine Lovatt has appreciated: “The Kosovan conflict has severely weakened the Romania economy. The Romanian government has toed the NATO line on action in Kosova, but the conflict has cost the sagging economy an estimated USD 750 million in lost trade and blocked Danube shipping.”<sup>5</sup> Those who declared themselves against the intervention in Serbia were actually not so much against West/United States as they were against the government’s policies and whatever the government was sustaining they were against. Of course, arguments of common nonconflictual history as well as the common Orthodox religion have played important roles in shaping people’s sympathy towards Serbia (but common Orthodoxy did not play such a role as in the case of Greece’s position in the same context). All in all, the anti-West feelings were not profound since they did not appear then after and actually no spontaneous mass-meeting was ever organized to support the “Orthodox brothers” from Serbia.

The attack on September 11 as well as the US intervention in Iraq in 2003 were positively reflected in the Romanian mass-media, the first one with sympathy while the second one with respect, the removal of Saddam Hussein being compared with the fall of Romania’s Nicolae Ceusescu. I remember the only demonstration organized in Bucharest in spring 2003 against the invasion of Iraq: some tens of people without much motivation, most probably being brought together by an NGO. At some point, a group of people with a white flag with a sort of black cross (the sign of neo-legionarists / neo-nazi) seemed to take the control but I did not pay much attention on what happened after, registering only the ironic fact that the flame of anti-Americanism was carried only by some Western funded NGOs joined at some point by the neo-legionarists.

One event which may contribute to a debate on Romania’s attitude towards United States is the case of Teo Peter, a famous Romanian rocker killed in an accident by an American soldier in 2004. The problems under discussion were why the soldier was 1) not judged by the Romanian authorities but no one complained after understanding that Romania was the first one to sign that treaty according to which Americans are protected from the jurisdiction of the International Criminal Court and 2) why he was not punished by the American authorities since he really was guilty - the soldier was driving drunk in the middle of a crowded city, Bucharest, after a party and consequently not being in mission or in legitimate defense. There were many cases of indignation<sup>6</sup> and I join this feeling especially after I understood there is a record of not condemning American soldiers supposedly being “in mission”—even if they are proved driving drunk! This record shows a sort of attitude of negligence from the American military authorities: it is well known that discipline is extremely important for the troops and in the same time any “foreign”

armies need the moral support/sympathy from the “natives”—and in this case, Romanians were treated as “natives”) This is the only case when there was a limited level of frustration but there was also a general trend of avoiding debates and “not paying attention to the case” since a privileged relationship with US was considered as a better position for Romania in negotiating its integration in the EU.

Another very much debated issue was the abduction of three Romanian journalists in Iraq in spring 2005. While in the beginning everyone was commenting on the American intervention in Iraq and its reasons, then after people started to ask why did they go in the middle of the danger knowing that they will not be protected and in the end the research on the case showed that these journalists had blurred relationships with their abductors. At the time of debate, according to the Romanian section of BBC, 40 percent agreed on the retreat of the troops from Iraq, while 42 percent were against. Also most of the comments were arguing that the Romanian troops are offering security and they are not troops of military occupation.<sup>7</sup>

Finally, the latest important events are the death of the fourth Romanian soldier in Afghanistan who together with other two deaths in Iraq makes a total of sixth dead soldiers in Afghanistan and Iraq, and the proposal for the retreat of the Romanian troops (only) from Iraq in June 2006. People proved to be sensible towards the death of the Romanian soldiers in Iraq and both President Traian Basescu and Prime-Minister Calin Popescu Tariceanu to participate at the funeral of the soldier, even if one may consider this a disproportionate decision. Several days later, maybe as a consequence of this event, the Prime-Minister Tariceanu and the Defense Secretary Atanasiu proposed to the Supreme Council for Country’s Defense CSAT the retreat of the Romanian troops from Iraq. The proposal is not reasoned by any form of personal anti-Americanism or as a result of a large people’s demonstration but only by the MP’s personal ambition to attract sympathy in his conflict with the President, the MP being the president of the Liberal Party while the President being the real leader of the Democratic Party, both parties winning the December 2004 elections. I am not wrong if I say that most of the people felt this would be an error.<sup>8</sup>

### **Why there is no Anti-Americanism in Romania?**

I already have stressed the fact that in nowadays Romania anti-Americanism sentiments are rather isolated at the level of some individuals and they are not manifested almost at all in the public space (mass-media, political discourses and programs, academia, different groups e.g. army, businessmen) as well as within the mass of the common people. In order to present the dynamics of these social

groups and their link towards filo-westernism and filo-americanism, I have distinguished between the longterm, midterm and recent causes.

### *Long-term causes*

The collective memory and identity of the Romanians were shaped since the nineteenth century up to the middle of the twentieth century by the contact with the ideas of Enlightenment, nationalism and liberalism thanks to the local nobles, and boyards, who started to travel in Western Europe in the beginning of the nineteenth century. A cultural and later social transformation helped Romania to change its “Oriental” aspect to a more Western one (the alphabet changed from Cyrillic to Latin, the clothes from Turkish to Western, the French model of state was adopted etc.) Even if most of the population of Romania did not change its aspect, through the army, church, and schools a process of nation-building was started aimed to uniformize the people and transform them into citizens, military conscription being in the second half of the nineteenth century the most efficient tool in the process of nation-building in then Romania.<sup>9</sup> Romanian identity was extremely influenced by the French culture, the basic idea of this identity being that Romanians represent a “Latin island surrounded by a Slavic sea,” this saying also contributing towards Romanians’ skepticism towards Russia. Belonging to “West” was the other basic idea of the Romanian identity, “Romania” being also conceived as a borderland of Europe/West.<sup>10</sup>

The positive role of the noble elite proved to be extremely beneficial in shaping a certain *esprit de corps* within the Romanian army. Since the upward mobility was possible and the nobles were not interested in the army, many urban inhabitants as well as peasants had the opportunity to gain a certain, much better, social status. Also, since the noble elites were dominating the economical, social and cultural activities, the officers did not create a specific public sphere but tried to integrate individually in the existing Francophile spheres. This is the explanation why in Romania there was never a military coup d’etat and the military body has always considered itself as subordinated to the civil authorities. For comparison, in the other Balkan countries, which did not have noble as elites in the nineteenth century but only peasants, the officers grouped themselves as a sort of a cast considering themselves above the law and in the legitimate position to intervene in the political life whenever they wanted.

What was the role of the Orthodox Church? The Orthodox Church, next to the army and schools, was one of the most efficient tools of the government in the process of nation-building. The impact with the Western values stressed its level of education, a sort of Orthodox Reform resulting from this contact with the West,

as the Catholic Reform was a reaction to the Protestant Reform in the XVIth and XVIIth centuries. The Orthodox Church has always obeyed the civil authorities in exchange for a certain level of autonomy: in the 1960s BOR was the only Orthodox Church to participate in Council Vatican II, while after 1989 it was the only one to invite and receive the visit of a Pope.

### *Mid-term causes*

While sentiments of anti-Americanism started to appear in Europe immediately after the end of the Second World War (mainly do to the US monopoly of nuclear power), in Romania, occupied/"liberated" by the Red Army, a strong desire for the coming of Americans started to appear,<sup>11</sup> a desire which has remained strong for a long time: especially in the 1980s, people were regularly listening to Radio Free Europe and Radio Voice of America.<sup>12</sup> After the invitation of Romania to join NATO, I remember the headlines: "After 50 years, the Americans are [finally] coming!"

Strong skepticism towards Russia and later Soviet Union (and in general anything "coming" from the East) dates back two centuries: during the first half of the nineteenth century, the Danubian principalities were frequently occupied by Russian troops—the Russian empire trying to annex their territory. In 1878 the Russian troops hardly left Romania even if a treaty guaranteeing this was previously signed. During the First World War, Romania and Russia were the only allies on the eastern front, the communication was bad, while the Bolshevik seizure of power has lead to the Romanian defection too in February 1918. The interwar period was dominated by the dispute on Bessarabia, while the "liberation" proceeded by the Red Army in 1945 was accompanied by a huge wave of thefts and rapes. This anti-Russian skepticism may partially explain Ceausescu's "politics of independence," while even nowadays the desire to integrate in the Euro-Atlantic structures is motivated by the anxiety towards Russia (gas distribution, the 14th Army from Transnistria).

The influence of American pop culture though jazz and Hollywood movies was felt in Romania since the interwar period. Since the early 1960s when Romania's communist regime started to distance itself from Soviet Union, Russian language was not compulsory anymore, while learning one foreign language—preferably English—has become compulsory. Another factor that helped the learning of foreign languages by Romanians was that subtitling was systematically used instead of dubbing.

### *Recent causes*

As I mentioned in the introductory lines, in order to understand the dissemination of the sentiment of anti-Americanism, it is important to pay attention to the dynamics of the social groups which are or may be the most important carriers of anti-Americanism: the intellectuals, the mass-media, the politicians, the clergy as well as the opinion of the common people.

The educated elites like intellectuals, professors, students mainly in humanities and political sciences, are by default pro-Western and most of them pro-American. "Illusions of grandeur" is the name of the chapter dedicated to the Romanian intellectuals by Alina Mungiu-Pippidi, the most reputed Romanian political scientist, professor at the National School for Political and Administrative Sciences and president of the Romanian Academic Society, the most important Romanian think-tank.<sup>13</sup> There are two reasons for this title: on the one hand, the humanistic education is most of the times set on the model of several great Romanian intellectuals who became great only after they migrated in France (Eugen Ionesco, Emil Cioran) or United States (Mircea Eliade and Ioan Petru Culiano, both teaching history of religions at the University of Chicago). And on the other hand, intellectuals were those who constructed the Democratic Convention from Romania aiming to re-establish themselves as the political elites of the post-Communist Romania.

Why do so many Romanian youngsters know English and why so many desire to go study abroad? Within many of the people of my generation, winning a scholarship at a foreign university is the only way to travel outside Romania. It is professionally prestigious, and the American universities are the most popular since they offer the most generous scholarships (compared to the French who offer several hundreds of euro per month and tuition of course). The explosion of Romanian students studying abroad, many of them choosing to come back home, may be explained also by the fact that during the Communist regime, the borders were hardly penetrable: the only possibility to travel abroad was only if you had some contacts inside the system or if you got a scholarship.

From my point of view, a great contribution in spreading a positive image of the US in Romania belongs to the philanthropist George Soros and his Open Society Institute. He is the founder of the university where I study and his foundations were quite generous in their effort of disinterest recyclation of the intellectual body by offering them scholarships to Western Universities, travel grants to those who already got scholarships from Western Universities but did not have enough financial resources, and most importantly OSI and CEU sponsored the largest and the most profound process of translation of Western, mainly American, literature



in Eastern Europe, especially in Romania, which had a great impact on the market of ideas.

The figures provided by Adrian Florea on the efficiency of spending the money on training soldiers in Bulgaria, Romania and Hungary do not necessarily mean that Romanian management is better. Other two explanations are that there is a much higher number of youngsters learning foreign languages (and desiring to travel abroad, to the magic “West”) as well as the fact that a high proportion of this young population see education as mean to accomplish their aim of improving their lives.

While the military and the economic elites are fascinated with the Western efficiency (earning an MBA is not the hardest thing for working student and in the same time since the 1990s there is a huge number of Romanian student fascinated with IT industry), mass-media is populated either by people who generally sympathize with the United States or mostly by people who have no opinion and execute their bosses’ orders. Other important explanations would be the lack of a real tradition of leftism, and nonetheless the lack of independence of the Romanian mass-media which is not at all the fourth power within the state. As the Romanian professor of political sciences Alina Mungiu-Pippidi appreciates, “[...] after a turbulent decade [1990-2000], it is clear that the model used by the Romanian mass-media is the “Turkish” one, and not the Hungarian, Polish or Czech models. That means that mass-media, in a great proportion the property of some local business men, have become, rather, instruments for winning political influence or an agent for deals [...]”<sup>14</sup>

As for the common people, the access to Schengen space since 1st of January 2002 represented the occasion for about two million Romanians to travel and work in Western Europe, mainly in Spain and Italy (due to cultural and language affinities). For them, the mirage of becoming rich, mostly disseminated through gossip from the three waves of emigration (before and after the second World War, mainly from Transilvania; during the Ceausescu period in 1970s and 1980s; and after December 1989) as well as the American film industry (not only Hollywood but also the soap-operas. “*Dallas*” was allowed to be broadcasted for the first time in Romania in the early 1980s with the argument it shows the evils of capitalism and the level of “exploitation” in the United States. Nonetheless the serial was stopped after Ceausescu realized that it contributed to the popularity of the US in Romania. Then after, “*Santa Barbara*,” “*Sunset Beach*,” “*the Young and the Restless*,” and “*Beverly Hills, 90210*” contributed to the Americanization of the urban youngsters in 1990s Romania.

In the 1980s, the privilege to have access to video-players was accompanied by the wide dissemination of the movies of Bruce Lee, Arnold Schwarzenegger, Sylvester Stallone, Bruce Willis, Eddie Murphy, Jean-Claude van Damme, while an important factor in the Americanization of the young generation is represented by the role of music: the wide spreading of pop music (Michael Jackson's concert in 1992 is famous), hip-hop and rock music.

## Endnotes

1 Jean-François Revel. *Obsesia antiamericană. Cum funcționează, care îi sunt cauzele și inconsecvențele*. [The Anti-American obsession. How it works, what are its causes and inconsistencies]. Traducere din franceză de Dan C. Mihăilescu (București: Humanitas, 2004). French edition: Editions Plon, 2002; English edition: Antiamericanism (San Francisco, Calif. : Encounter Books, 2003).

2 Revel, Romanian edition, p. 11-14

3 By the way, Adrian Nastase was the Foreign Relations Minister in 1991 when the treaty with the Soviet Union was signed.

4 Catherine Lovatt, „Romania and the Kosova Crisis [in 1999], *Central Europe Review*, nr. 32, 3rd of May 1999, Internet: [http://www.ce-review.org/authorarchives/miorita\\_archive/miorita32old.html](http://www.ce-review.org/authorarchives/miorita_archive/miorita32old.html); August 1st, 2006.

5 Catherine Lovatt, „Is Romania’s government crumbling?” *Central Europe Review*, nr. 37, 7th of June 1999, Internet: [http://www.ce-review.org/authorarchives/miorita\\_archive/miorita37old.html](http://www.ce-review.org/authorarchives/miorita_archive/miorita37old.html); August 1st, 2006.

6 [http://www.bbc.co.uk/romanian/forum/story/2006/02/060202\\_teo\\_peter.shtml](http://www.bbc.co.uk/romanian/forum/story/2006/02/060202_teo_peter.shtml); August 1st, 2006.

7 [http://www.bbc.co.uk/romanian/forum/story/2005/04/050425\\_retragere\\_Iraq.shtml](http://www.bbc.co.uk/romanian/forum/story/2005/04/050425_retragere_Iraq.shtml); August 1st, 2006.

8 [http://www.bbc.co.uk/romanian/forum/story/2006/06/060629\\_militari\\_Iraq\\_retrage-re.shtml](http://www.bbc.co.uk/romanian/forum/story/2006/06/060629_militari_Iraq_retrage-re.shtml) and [http://www.bbc.co.uk/romanian/forum/story/2006/04/060427\\_militar\\_mort.shtml](http://www.bbc.co.uk/romanian/forum/story/2006/04/060427_militar_mort.shtml); both accessed on August 1st, 2006.

9 Silviu Hariton, „Conscripție militară și educație primară” [Military conscription and primary education in Romania, 1860-1900], *Revista de Istorie Militară/Romanian Journal of Military History*, Nr. 6 (60), 2003, pp. 36-43.

10 Lucian Boia. *Romania: borderland of Europe*. Translated by James Christian Brown (London: Reaktion Books, 2001) and Lucian Boia. *History and myth in Romanian consciousness* (Budapest: CEU Press, 2001 [1997]); Sorin Antohi. „Romania and the Balkans. From geocultural bovarism to ethnic ontology,” *Tr@nsit online*, nr. 21, 2002, Internet, August 1st, 2006.

11 Through many others, Silviu Brucan interviewed by R.D. Kaplan. See Robert D. Kaplan. *La răsărit, spre Tartaria. Călătorii în Balcani, Orientul Mijlociu și Caucaz*. Traducere de Dorin Nistor, Simona Drelciuc, Alina Pelea (Iași: Polirom, 2002) [Eastward to Trataray. Travels in the Balkans, the Middle East, and the Caucasus (New York: Random House, 2000)]

12 Bogdan Barbu. *Vin americanii! Prezența simbolică a Statelor Unite în România războiului rece* [The Americans are coming! The symbolic presence of the Unites-States in the Cold War Romania] (București: Humanitas, 2006)

13 Alina Mungiu-Pippidi. *Politica după comunism: structură, cultură și psihologie politică* [Romanian politics after communism: structures, culture, and political psychology] (Bucharest: Humanitas, 2002), chapter VII, pp. 152-172.

14 Mungiu-Pippidi. *Politica după comunism...* [Romanian politics after communism..], p. 134.



## **Day 3, Panel 7 Question and Answers**

(Transcript of Presentation)

**Moderated by  
Mr. Kelvin Crow—Combat Studies Institute**

**Mr. Kelvin Crow**

We have time for some questions for the panel.

**Audience Member**

Thank you all. One of the most enlightening things was just how the Romanians adapt old systems and make them new. And this is a question for the panel, what would you identify as the distinctive cultural or educational or social attributes of Romania which allows them to adopt ... to have this capability?

**Mr. Joseph M. Isenberg**

It's always dangerous to make cultural generalizations, of course, but there are two aspects to it. The Romanian educational system is very high class, and it's very specialized at the high school level. And you're tested. And you go in to a track ... or at least you did. I don't know if they still have that. But Mr. Florea went into the language track, and he speaks what? Something like four languages, and had Latin going through high school, because it helps learn the Romanian. The Romanian technical education would be similar. It's highly specialized. They're formidable. Mr. Hariton, as an undergraduate I met, and I was then a doctoral candidate. He started asking me detailed questions about American History, and I walked away two hours later feeling as though I'd been mugged. I had to go lie down. So the Romanians specialize, so whatever they do in their, kind of, track, whatever they do, they do very well. And they have to do it very inexpensively. My colleagues may now hit me if they wish.

**Audience Member**

Thank you. Again, I'm the senior brigade trainer from the Multinational Readiness Center. I guess I'd offer an observation, particularly in my work with the Romanians over the last six months, and then ask you a question. This is more a did you know. In February of this past year, a Romanian company participated in a mission readiness exercise for an American brigade preparing to deploy to Iraq. In May, a US company participated in a mission readiness exercise in Romania for a Romanian battalion that was preparing for deployment to Afghanistan. In June, that same company and the Romanian battalion returned to Germany and conducted

a second mission readiness exercise in preparation for deployment to Iraq. As of last month, the 140 US soldiers from the OPFOR Battalion deployed as the quick reaction force company attached to a Romanian battalion underneath a NATO flag in Zabul, Afghanistan. So I guess in terms of demonstration of commitment, I can't tell you how much further you can get in demonstrating the US resolve to participate as partners with Romania. I would tell you that the Romanian officers, from the general officer down to the field grade officers, are very focused in their insistence that they partner up with the United States. But as a second thought to that, I'd ask you what NATO's and the European Union's role is in both training and equipment and working with Romania, and whether or not there is some potential for Romania to stiff arm the EU for a solely US approach to their security arrangements?

**Mr. Adrian Florea**

First of all, it is worth mentioning that by pursuing its double security guarantee, Romania is not only committed to strategic alliance with the United States, but also is concerned with obtaining extra security guarantees through multilateral security alliances. Here I have in mind NATO and the envisioned European security architecture. That doesn't mean that Romania is not firmly committed to the US and Romanian strategic partnership. It means that the great power of security guarantee has primacy over the multilateral system. And that is to be seen at the operational and maneuverability level.

Romanian forces have not regionally been well equipped to serve as combat forces, as you might have well noticed during your experience in the US Army. However, they have traditionally been well equipped to serve as stabilization and post-conflict resolution forces. And this is an area where Romania could fill a critical gap in terms of operational capability.

**Mr. Joseph M. Isenberg**

Because of the nature of their history, the Romanians have not been traditionally well equipped to serve as combat forces, but they have been willing to do so. So if they were well equipped to do so, they would be a very valuable component, based on what they've done historically.

**Audience Member**

For any one of you gentlemen, particularly Drew, Dr. Schumann. There seemed to be a lot of cooperation with Israel, which is not the norm in Europe. Could you explain some of the background of that?

**Major Drew Schumann**

Actually, I think Romania feels a certain affinity toward Israel. They're both small countries surrounded by people who, given a chance, would do damage to them. And they also view themselves as a Western country, despite their neighbors not being particularly Western. I'm not in any of the agencies that can tell us for a fact, but it appears as if there may be some second-hand assistance going on. I'm not sure. That's just total guess work on my part, but it is very eerie how closely they are working together.

**Mr. Silviu Hariton**

May I add a historical footnote? In 1967, Romania was the only eastern European country who recognized Israel, and for them ... I mean Romania, and during [inaudible] regime, tried actually to play some kind of international role mediating, for example, the Palestinian and the Israeli conflict. Tried to keep close ties with both of them.

**Audience Member**

And there was a technology interest in the prior regime, also. It's a long standing ...

**Mr. Silviu Hariton**

Actually, one suspicion towards Romania was actually this political independence toward Soviet Union, was only a mean to gain Western technology, which was sold. I don't know, but most probably I'd say to the other Warsaw Pact countries.

**Mr. Adrian Florea**

It is also worth mentioning that for both Israel and Romania, threat is proximate and immediate. So they share the same security conception, and this translates into a comprehensive security partnership at the moment. Romania, Israel, and Greece, to some extent, have had some joint operations in the Mediterranean Sea region, quite lately, in 2004 and 2005, if I'm not mistaken. But mainly, ideological reasons also play their part into this strategy partnership. And we do actually take American technology through Israel companies.

**Mr. Kelvin Crow**

Any other questions or comments for our panel? Thank you very much. I believe you've made your case quite well.





## **Building Iraqi Security Forces From the Bottom Up: Task Force 2-2 and the 205th Iraqi Army Battalion in Muqdadiyah, Iraq**

(Transcript of Presentation)

### **Lieutenant Colonel Peter Newell—US Army**

I wanted to first say thank you to the Combat Studies Institute (CSI) and to all of you. This has been a particularly rewarding experience for me for the last three days. It's not often that a guy gets out of the trench for a little while and talk and listen to subjects that are so completely wrapped around what I do for a living now. As I've said a couple of times today, I'm Lieutenant Colonel Pete Newell. I am currently the Senior Brigade Trainer at the Joint Multinational Readiness Center (JMRC) in Hohenfels, Germany. And again, JMRC is, and always will be, our nation's only forward deployed maneuver training center, and just like Joint Readiness Training Center (JRTC) and National Training Center (NTC).

The subject I was asked to talk about today is one that is near and dear to my heart and my experiences in Iraq. And this is building the 205th Iraqi Army Battalion in Muqdadiyah, Iraq. I'm a veteran of Operation IRAQI FREEDOM II (OIF2) from 2004 to 2005 in Iraq, so the subject today is really our experiences ... and I say "our" because as a Task Force Commander, one of the things I learned early on is that you find the right people to do a job and you give them a lot of space and let them do it. When it comes to building this Iraqi Infantry Battalion, I could take credit for having a couple of good ideas, and one of the first ones is hiring the right guys to do this. I will tell you that I continually say "we" and "our" because not much of it has to do with me personally. It is about a team of soldiers who came together with the right ideas in the right place.

It is really a story of how we got from here (Slide 1), and yes, those are sticks with rags tied around them that we're using to pretend as weapons, to here (Slide 2), to there (Slide 3), in eight short months. All while we're involved in combat operations. And I will tell you the observation that doing this is like trying to fix a combat aircraft while in flight, is truly a great depiction of what we've been asked to do and what we have done in Iraq for the last several years.

Things I'm going to talk about today. First, I'll give you a general overview of Muqdadiyah, Iraq and our area of operations (AO), and what we found when we arrived in February of 2004. I'll talk about Commanders Intent, only because I think it's important to understand that in putting ... in building the Iraqi battalion was not an end to a means itself. It fit within a context of defeating an insurgency.

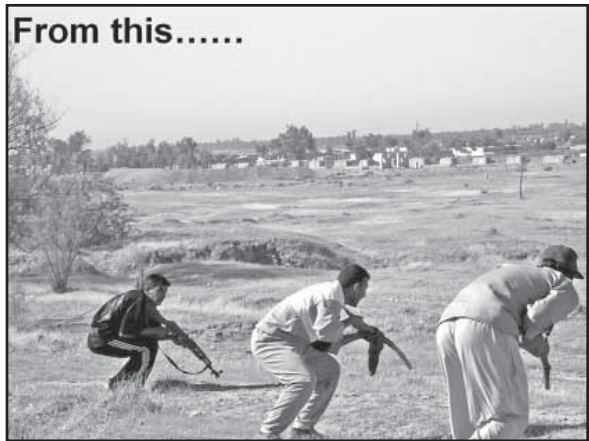

Courtesy of LTC Peter Newell, US Army

SLIDE 1



Courtesy of LTC Peter Newell, US Army

SLIDE 2



Courtesy of LTC Peter Newell, US Army

SLIDE 3

All of that is wrapped inside our purpose for being, and what we intended to accomplish over 12 short months. We'll talk about recruiting and training, rebuilding, not just facilities, but facilities, systems, and confidence in Iraqi soldiers to execute their duties. I throw mentoring down there at the bottom, only because the question came up the other day about how much time a US Task Force Commander spent dealing with personalities and establishing relationships. And I'll tell you my response to that question is 99.9 percent of my time was focused either on building Iraqi civilian leader relationships, tribal military security force, dealing with my own soldiers and my desire to have them work more closely with the Iraqis, and in my own leaders, who were the guys who provided me resources to execute my duties. So I will tell you that this is tantamount to everything we do, all day long at that level.

Muqdadiah, Iraq, located about 75 miles northeast of Baghdad (Slide 4). The closest major city, Baquba, located about 30 miles to the southwest, and is where my brigade headquarters is located. Muqdadiah, as I mentioned the other day, is a largely agrarian area, broken up into five major areas, in an area that is known as the "bread basket", which is really closer representative to Vietnam than it is to

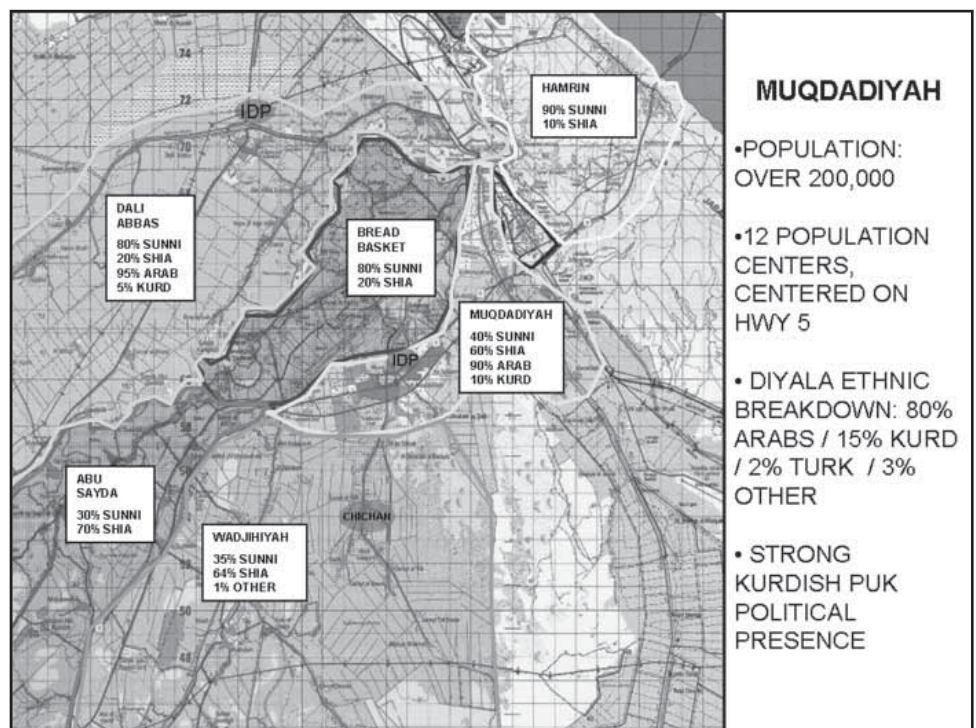

SLIDE 4

a desert. It is triple canopy, date palm grove jungle with nothing but grapevines in between. An absolutely impossible place to move around in.

The nahia's (naheeah). In the center is Muqdadiyah. The city center where the majority of the population live that was not involved in the agricultural aspects of society. As you can see, 60 percent Shia, 40 percent Sunni. A Kurdish population with a significant political backing. The north of this reservoir up here, the towns of Jalula. This is what we call the brown line, and this is where the Kurdish population was starting to move to, so this truly was the transition point between the Kurdish areas to the northeast and the Arab areas to the southwest.

To the north, the bread basket and Dali Abas, both areas that were largely Sunni. 80 percent to 20 percent in both cases. To the south, Abba Sadr and [inaudible], both primarily Shia areas. A strong presence south of this area. Forward Operating Base (FOB) Normandy, which sat right in the center of this thing, is a former home to the Iraqi 3d Corps, formerly housed somewhere between 8,000 and 10,000 soldiers. 6,500 of those soldiers still lived in Muqdadiyah, and all of them were out of work.

FOB Normandy itself, located at the headlands of the Diyala River basin (Slide 5). Right here is where the irrigation sluice gates started that drove all of the irrigation for this valley between Baquba and Baghdad. At the top was a hydroelectric power dam that fed 60 percent of the power that went into Baghdad. FOB Normandy, as I mentioned, home of the 3d Iraqi Corps, 6,500 soldiers still living in the area, all of them out of work. On the ground within FOB Normandy, a corps' worth of ammunition stored in 34 bunkers. And another division's worth strewn on top of the ground that had the propensity to detonate in the mid-summer heat without notice. Probably at least another division's worth, pilfered from the FOB, and existed in various bunkers, homes, holes, garages, and other places in this AO. Finally, FOB Normandy was the storage point for the equipment that belonged to the Mujahideen Kahlq, (MEK) a former declared terrorist organization. So on this FOB, I owned more tanks and BMPs, and more Howitzers and cannons than the entire US Corps in Iraq. Most of it functioning equipment. You just had to have the expertise to figure out how to start the stuff and move it. But it was there.

The good news for us is the MEK also left all of their AK-47s, their rocket propelled grenades (RPG), their ammunition, and a large amount of other equipment stored either buried in the ground or stuffed back in to various bunkers. It was just a matter of going through and opening and inventorying somewhere around 60 different facilities that they had stuck stuff in.

FOB Normandy itself, although not damaged in the war, was so thoroughly looted that the buildings literally had started to collapse on themselves. When you walk into a building the windows, the frames, the doors, the wiring, the plumbing, all of it gone. What it was though is huge potential, both in terms of creating a new Army, and exceptional potential for creating an insurgent force in the region. You'll find that, at times, I wasn't sure how many of these guys were just fighting because they needed money in order to feed their families. And I'm sure that 90 percent of it, that's what the case was.

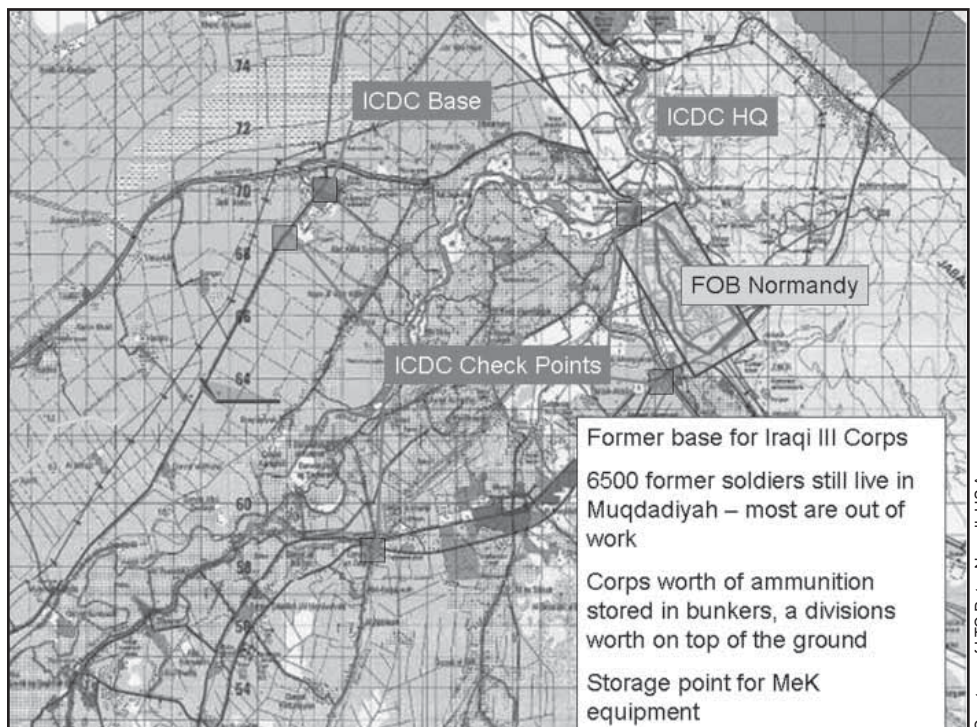

SLIDE 5

I'll talk a little bit about, with that in mind, the Commander's Intent that I gave to the soldiers in early May, after redeploying from the job. I'll talk about the decisive point in the operation (Slide 6), and that is merely separating these guys from the population. In my mind, if I could separate the insurgent from the population, I can find the insurgent, I can either kill him or at least I can put him some place where he can't damage our ability to move along. Key in that, is not people seeing us, the US, as the answer, but them seeing their own government and security forces in the future Iraq. So in any case where there was a US guy standing up saying, "Look what I've done for you," I grabbed him by the back of the neck and pulled him back. That is not what I wanted to hear. I wanted to hear, or see, an Iraqi official, an Iraqi Army officer, somebody else standing up front saying, "I'm here and I can do this."



## Decisive Point

- Decisive point remains separating the insurgents from the Iraqi population. We must continue to cut off the insurgents' physical, morale, political and economic support. **People must see the local government and security forces as the future of Iraq and the insurgents as a threat**



Courtesy of LTC Peter Newell, US Army

SLIDE 6

The key tasks (Slide 7). All of this applies to how we built this Iraqi battalion. Aggressive intelligence gathering. Obviously, I don't have a human capability. On FOB Normandy, I did have an ODA Team (Special Forces Operational Detachment A-Team) and a single counterintelligence team, both with unique expertise, but somewhat limited capability because we are still Westerners in a mid-East society.

Using continuous I/O. It's not a matter of me delivering a message as it is me convincing an Iraqi to deliver a message. In a lot of cases, my dealing with the Iraqi military leaders or Security Force leaders, expressing a concept to them and then listening to them to express back to me the best way to do that. Or telling me the concept was completely Fruit Loops and not worth the effort, because it wouldn't ... it just wouldn't mean anything to the folks.

Increasing Iraqi involvement in the government Security Forces. And key is make them successful, sometimes despite themselves. But make them do it right, make them earn the trust of the population.



## Key Tasks

- **Aggressive intelligence gathering and fusion** to identify insurgents and their cell leaders. Use intelligence to target tactical operations against insurgents. Use targeted I/O to let Iraqi's know who the threats are in their neighborhoods (physical/morale separation)
- Use continuous I/O messages to defeat the ideas that support the insurgents. **Get a broad base of Iraqi faces and voices to deliver the messages** (morale separation)
- Increase Iraqi involvement and reliance on their government and security forces. **Make them successful, respected organizations** (political separation)



Courtesy of LTC Peter Newell, US Army

SLIDE 7

Increase the cost of doing business for the insurgents (Slide 8). Again, I talked about those 6,500 out of work ex-military guys. It is one thing for an ex-soldier to go home to his family to have his wife tell him, “Don’t come home without money or food the next time,” and have your kids say, “You’re no longer my father because you can’t take care of me.” That’s what happens in this society if you can’t take care of your family. We need jobs, we need security, most of all, we need a means for these guys to feed and take care of their families, other than taking \$10 an attack to go out and shoot at US forces. Again, put the blame for lack of progress back on those that incite violence. It’s not take credit for things that are going well, it’s a matter of put the blame in places where things aren’t going well on the guys that are really causing it.

And finally, I’ll talk about not fighting fair and not fighting a linear battle. This is not about the tactical war, but it’s about attacking the ideas that support the insurgency and recognizing that the insurgent speaks the native language, he understands the rumor mill, and he can get a message delivered in a nanosecond. Something that takes weeks for us to figure out how to do.



## Key Tasks (cont)

- Increase the cost of doing business for insurgents and **give Iraqi’s another way to earn a living other than supporting insurgents’ attacks.** (economic separation)
- Leverage CMO projects to reward areas that support the government and I/O to target those that do not. **Put the blame for a lack of progress on those that incite violence** (economic/morale separation)
- Use deliberate, planned and rehearsed operations that insure 360-degree security, overwhelming force and mutual support to tactically defeat insurgent attacks – **don’t fight fair and don’t fight a linear battle** (physical separation/force protection)



Courtesy of LTC Peter Newell, US Army

SLIDE 8



Our timeline (Slide 9). We assumed the AO on the 14th of March, 2004. We replaced a task force at FOB Normandy that really had not been there very long and did not create much of a structure. They had had time to create the first Iraqi Civil Defense Corps (ICDC) Battalion, a battalion led by an Iraqi Air Force Captain, or former Iraqi Air Force Captain, who spoke English. Had cobbled together what we thought were roughly 400 ex-military guys and turned them into a couple of companies. In reality, Sabbah, the ex-Captain, had created a smuggling organization that was designed to further his economic prospects in the country more than it was to provide security. As we got closer and closer to our TOA (transfer of authority), it became more and more apparent that our Iraqi Civil Defense Corps Battalion was a criminal organization more than it was providing security to the AO.

On the 8th of April, literally three weeks after TOA, Muqtada al Sadr stood up, challenged virtually anybody he could, and incited significant attacks in my own AO. To the point where literally conducting company sized movements to contact through the town of Muqdadiyah to clear out pockets of insurgents who were trying to control the roads. The Iraqi Civilian Defense Corps Battalion abandoned the

 <h2 style="text-align: center;">Timeline</h2>	
Mar 14, 2004	Task Force 2-2 assumes AO
Apr 8, 2004	Significant attacks in Muqdadiyah Task Force (-) ordered to An Najaf Task Force CDR detains ICDC CDR
1 May, 2004	Task Force redeploys from An Najaf
10 May, 2004	Task Force Cdr re-issues Cdr's intent
4 June, 2004	Begin recruiting ICDC Companies Establish FOB Normandy Training Facility
1 Jul, 2004	Iraq Sovereignty
9 Oct, 2004	205 <sup>th</sup> graduates last platoon from initial training Diyala Regional Training Facility (DRTF) Opens 205 <sup>th</sup> begins Advanced Training POI
2 Nov, 2004	Task Force (-) deploys to Fallujah
29 Jan, 2005	Iraq Elections
1 Aug, 2005	205 <sup>th</sup> assumes control of Muqdadiyah AO



Courtesy of LTC Peter Newell, US Army

SLIDE 9

post, all except about a 15-man element that had been working with the ODA for the past six months. On the 8th of April I was ordered to deploy half my task force to Najaf, ostensibly to quell Sadr's uprising, more a case to demonstrate the United States' resolve not to allow him to continue to expand his violence.

Unfortunately, the same day I also decided to throw the ICDC battalion commander in jail. We conducted a raid on his house and found two duffel bags full of Iraqi currency, literally this high, this big around, where he had been skimming money from the pay of his own soldiers for the past eight months. Buried in his back yard were several large caches of illegal weapons, and in a barn further behind his house, a collection of procured ex-military vehicles that he was selling up north in the Kurdish region.

Left in charge of the battalion was a Lieutenant from that 15-man element that had been working with the ODA. Lieutenant Thear, spoke English very well, proved to have a very open approach to how the Iraqis had to survive. Thear was a former Intelligence Officer who worked in Baghdad underneath Saddam Hussein's regime.

On the 1st of May, we redeployed from Najaf, and literally had to start over in our AO. After three weeks, we got in a big fight, picked up and left, except for a very small contingent of my task force, who was really left just to secure the FOB. My guidance to the ODA and to Thear before I left was save what you can of this battalion and get rid of the rest. What we found out of that 400-man element is that there were only 300 people actually working. The other 100 were ghost soldiers. Sabbah was drawing pay for them, pocketing it and using that to do various other things. Only about 300 of those guys were showing up. Interesting to note that in areas like this that are very remote, there's no transportation. So out of your 300 soldiers, you could only find 150 on any given day because they worked 24 hours on, 24 hours off because of the cost of transportation. It's expensive to ride a cab back to work twice every day, so their decision is we'll go 24 on, 24 off. Obviously, having worked for a long time, you realize that if somebody works for 24 hours, particularly in an area like this, you may get six hours productivity out of them. So at any given time, out of that 300 guys, you might find 50, if you were lucky.

On the 10th of May, I came back and redid this Commander's Intent, the one that I just showed you. And the recognition came while I was in Najaf, I showed up in an area that had not had a US presence and realized that we were absolutely helpless. We had three interpreters. We couldn't talk to people. We didn't know anything about the AO, and had an exceptionally difficult time gathering intelli-

gence to even do anything other than drive around and do a presence patrol, which is not going to get you far.

By the 4th of June, I had assigned the two best and brightest guys I had in my battalion, and I talk about commitment hurts. This commitment hurt. I took Captain Brian Ducote, who I would describe as probably the top 1 percent of all the company grade officers I've ever worked with. A guy who was the best and brightest assistant S-3 I had in the battalion, who I would have easily put in a company command in a heartbeat, had there been one for him to command. Brian displays those people skills, not only in leadership, but he is one of those people that just seems to be able to gather people together. Extremely intuitive. Understands body language. Has exceptional listening skills, management skills, and speaks three different languages. He is the type of guy that can actually get out and gather these guys together and make them believe in him.

The other guy that I sent with him was my Operations Sergeant Major, Sergeant Major Darrin Bohn, a Ranger Battalion First Sergeant from Afghanistan that had been with the battalion at Kosovo, and worked extensively with the Kosovar Security Forces and the militaries from a number of different countries, so a depth of experience, both in combat and with working with other people.

Between those two guys, we started this over again. On the 4th of June, we established a process of recruiting the ICDC companies, and they set up parameters for doing that, established the FOB Normandy training facility. My FOB is 5 ½ kilometers long, 3 kilometers wide. If you whack out the spontaneously detonating ammunition dump, it still left a significant amount of room to train and house people. Significant event on the 1st of July, when we gained Iraqi sovereignty, which is when we started getting to the point that we really could push the Iraqi Security Forces to the front and say, "Look, it is your country. You have to do this."

On the 9th of October, the Diyala Regional Training Facility, which is this animal here, plus about a half million dollars and a couple months of construction, now not only takes care of my Iraqi battalion, but has now been expanded to do the exact same thing with the entire 32d Iraqi Army Brigade. That's the entire AO.

We hit a bump in Fallujah, for the second time, when I was tasked to deploy a significant portion of my task force for combat operations with the Marines. Actually, this is the only time we ever stopped training because we flat ran out of bodies. Without my soldiers in the AO, it was up to the Iraqi Army Battalion to assume a significant amount of battle space.

29th of January, Iraqi elections. I will tell you, in my AO, this was an Iraqi run operation. US forces did nothing but sit in small pockets, well away from anything, prepared to react to disturbances. And we never did.

Finally, on the 1st of August, this battalion assumed control of the entire Muqdadiyah AO from the task force that replaced me. So from 14 May 2004, where there is no security structure, to this point in August, 2005, where the Iraqi Army Battalion now owns the entire AO, and the US force is now dedicated to do something else, somewhere else.

Talking about recruiting of soldiers (Slide 10), and one of the things that I thought about in the Commander's Intent was ensuring that the population took ownership of their security forces. I will tell you that we started out building the Iraqi Civil Defense Corps, which was not the Iraqi Army. This organization was designed to fight a counter insurgency, not to provide a pool of people who could be deployed around to quell violence in other places. For instance, our reconnaissance platoon never wore a uniform, never carried a weapon. They were trained to use digital cameras and GPS'. They drove taxis, they worked in shops, and they never set foot on the FOB. Their job was to gather intelligence and find the targets of the people that we were looking for. They never conducted a raid, they never participated in a raid. Their sole purpose in life was to gather intelligence in the AO.



## Recruiting Soldiers

- Recommendations were taken from local leaders to ensure a variety of tribes had members apply for the ING. The intent was to not only encourage diversity but to also have local leaders take ownership over the ING.
- Each recruit had a packet that retained a copy of their identification and results from the screening processes and the physical fitness evaluation.
- All applicants were medically screened by an ING doctor. They were checked for rashes/illnesses and were questioned on their medical history.
- A board of ING leaders was formed and interviewed each candidate. Recruits were judged on their ability to communicate and how they carried themselves.
- A limited background check was conducted through current ING members and the Muqdadiyah police. Soldiers were called upon to verify each candidate's information.
- A second board comprising of local civil officials reviewed the names selected and approved the final recommendations.

Courtesy of LTC Peter Newell, US Army

SLIDE 10

The first thing, we know that we need the local leaders. The sheikhs, the politicians, the political parties involved in this process, if we want them to believe in this battalion. It is truly a matter of going to them and saying, "From every town, every sheikh, I want five names. The five most trusted people you have that you want to be part of this Security Force." And we built a dossier of 2,500 people, a package of their recommendations of people they wanted part of this battalion. We obtained permission from the brigade and the division commander to not only recruit the missing soldiers we had, but to add a fourth company to the battalion. So we have gone from having, ostensibly, 400 people on the books down to really only having 300, down to firing 150 of the criminals that belonged to the first Battalion Commander, to now expanding back up to about 800 soldiers. And had to do this very rapidly.

Every recruit that came in, obviously, first had to have, no kidding, an ID. He had to be able to prove that he was born in Iraq and was a local. Had to be able to read and write. Had to pass a medical screening. We actually brought in and hired an Iraqi National Guard doctor to actually look at every one of these guys so that we didn't get the disease-ridden, the invalids, the 80-year old men who, because he was a senior father left in the family and he was responsible for feeding them, he was pushed forward in order to get a job. We built a board of Iraqi National Guard (ING) and Security Force leaders. This actually was the Amir of Muqdadiyah, the Iraqi Army Battalion Commander, Thear, and the Muqdadiyah police chief.

And the key was, each candidate that came in would actually have to go through an interview and say, "Why do you want to do this? Why do you want to be part of the Security Force?" We're looking for guys with an open mind, but ones who's answer was generally, "I want to do this for my country." Not because I want to make sure it's a Shia dominated force or a Sunni dominated force, or I just want to feed the family. But we were really ... as we started looking for the leadership of this battalion, we were looking for the guys who sounded a lot like us. Ones that say, "I want to do something for my country."

We conducted a limited background check. Quite honestly, this was a crap shoot. It was a matter of whether the police chief knew the family, knew the tribal elders, whoever else, and had somebody who could vouch for this guy as being of good character. Finally, in order to quell the complaints of nepotism and corruption and everything else, with all of these tribal elders and other people, they put together a board of guys, the three town mayors, the police chief, and the head of the sheik's council, to sit down and review all the names, once we made the final cut, and said, "These are the 800 guys we're going to hire." To show that they completely understand that it was a completely fair process and that it was repre-

sentative of virtually every town and every tribe in the region. Thear went so far as to build on his wall in this room a chart that listed all of the soldiers he was hiring, all of the tribes, and then all of the towns. He literally, by hand, and placed a tick mark for every one that he has hired. Easy for him to demonstrate to anybody who wanted to challenge whether he was hiring just his tribal members or just his family members, that he clearly had plucked somebody from all over the place.

In talking to Thear later on, and I probably should have caught it earlier, Thear understood what made the Baath party successful in Iraq. Thear was an Intelligence Officer. He understood the Baath party was successful because the Baath party had members in every hovel, hamlet, farm, and town in Iraq. And they had an incredible way of gathering intelligence and information. Thear didn't miss that when he started putting this battalion together to fight the insurgency. He wanted inclusion, but more importantly, he wanted somebody from every one of those towns, as they started gathering information and looking for the people. He wanted a means of communicating into the towns. It's kind of a two-way street. But sometimes I have to warn myself that ... I continually warn myself, I'm working with a former Intelligence Officer who's really good at what he does. And proved exceptional at it.

Recruiting held over three days (Slide 11). The intent was to hire 800 guys. Now this was at a time, if you read the press or you listened to people that hadn't

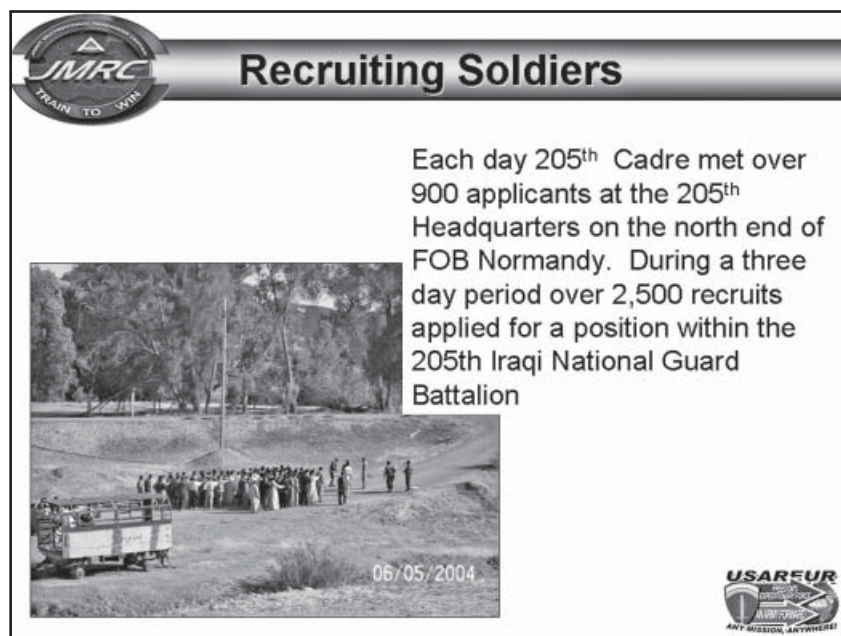

**JMRC**  
TRAIN TO WIN

## Recruiting Soldiers

Each day 205<sup>th</sup> Cadre met over 900 applicants at the 205<sup>th</sup> Headquarters on the north end of FOB Normandy. During a three day period over 2,500 recruits applied for a position within the 205<sup>th</sup> Iraqi National Guard Battalion



06/05/2004



Courtesy of LTC Peter Newell, US Army



SLIDE 11

been around and said that nobody wants to join the Iraqi Security Forces. You can't get police, you can't get soldiers. In three days, 2,500 people showed up to apply for those 800 jobs. Literally camped outside the gates and on the northern side of the post. Came in whatever they owned. Ready to take the test. Ready to raise their hand and say, "I want to be part of this."

Physical tests run by the Iraqi battalion, not by the US guys, but by the Iraqi battalion (Slide 12). Brian Ducote and Sergeant Major Bohn overseeing it. Again, we're looking to see if the guy is physically capable of withstanding the rigors of basic training and the rigors of performing.



## Recruiting Soldiers



Recruits were marched to a physical fitness site and performed a variety of physical Evaluations to include push-ups, sit-ups, pull-ups, and wind sprints.



Courtesy of LTC Peter Newell, US Army

SLIDE 12

Wind sprints (Slide 13). You notice there is not a single shoe on any of these guys, and they are running across a rocky field. If that's not an expression of desire to be part of an organization, I don't know what is.

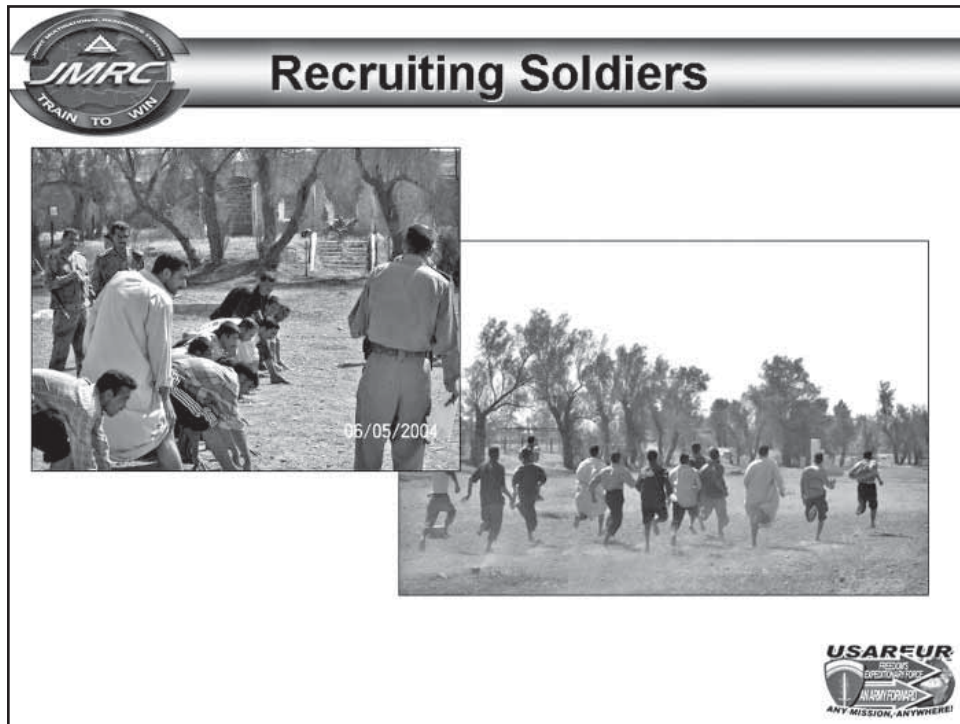

The slide features a header with the JMRC logo (Train to Win) and the title "Recruiting Soldiers". It contains two photographs: one of a soldier observing recruits in a field with a date stamp of 06/05/2004, and another of recruits running across a rocky field. The USAREUR logo is in the bottom right corner.

Courtesy of LTC Peter Newell, US Army

SLIDE 13



The Commanding General (CG) mentioned in his speech the other day about before you start you pretty much have to know what it is you intend to do with this organization (Slide 14). We were fortunate at the same time the 1st Infantry Division was working very hard at putting parameters around the ICDC. What is an ICDC soldier supposed to be able to do? What does an ICDC battalion have to be able to perform in sector? And at the same time, they were building what would become the 4th Division's basic training center and Primary Leadership Development Course (PLDC), the training for the noncommissioned officers (NCO). We were fortunate that all of this stuff happened at the same time as we were getting ready to build this new battalion. There wasn't a whole lot of thought on my part on what we had to do. I simply took the slide from the CG, gave it to Brian and said, "What more do you need, other than resources?"

These are the individual tasks that we focused on. I will tell you that what you see in blue is what we said, "We have the ability and we have to do." Operate a radio. Not a problem. I don't have any radios. Don't need to focus on that one for awhile. International Military Tribunal (IMT). We've got a long way to go before we get there. Basic rifle marksmanship (BRM). Before you start shooting bullets,

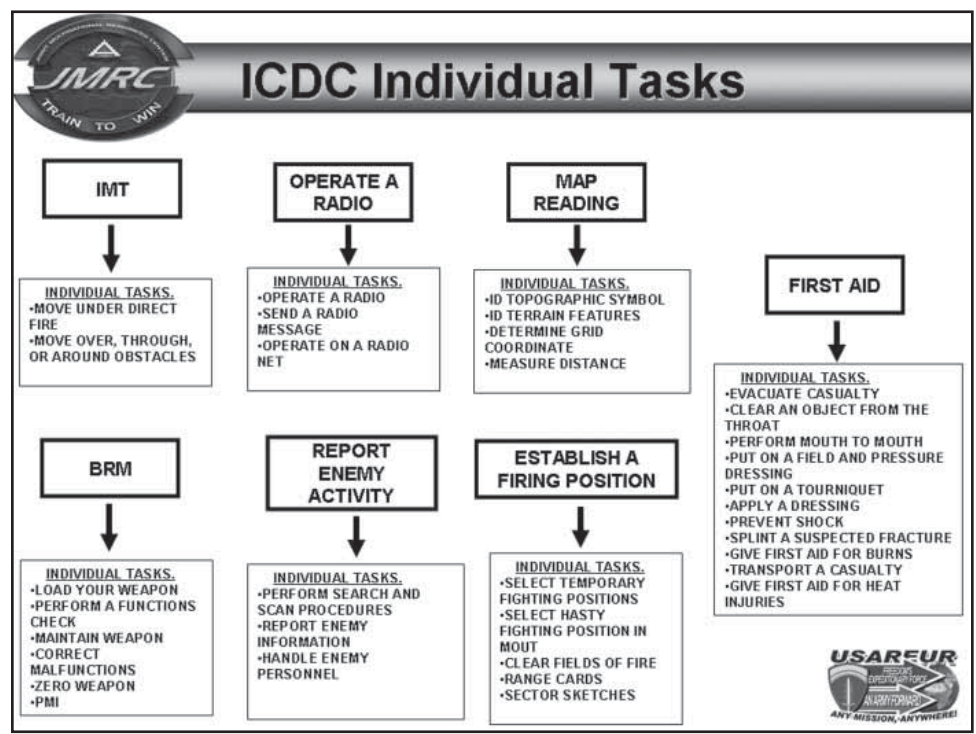

SLIDE 14

obviously you had to teach somebody how to do first aid and map reading. We found that the things that we thought, if we taught the soldiers to do these things, at least we could employ them in pockets and actually get something back from them.

Mission Essential Tasks for ICDC units (Slide 15). Again, you'll kind of see highlighted in blue down here what we thought that we could get to strictly on our own means. Without having to send guys away or having the ability to create another school. We focused initially on these squad tasks, and then on these platoon tasks, knowing that we would build, eventually, a mechanism to get to here and to here, but in our mind, this was about as far as we would get in 12 months with this battalion. I think we did much better than this, but that was a start.

Keys. Deliberate traffic control points, secure a fixed point, conduct a dismounted patrol. These are all very indicative of what the ICDC was doing at the time. They were strictly a fixed point security force. Eventually we wanted them to get to this point, conduct a cordon, conduct a raid, provide Quick Reaction Force (QRF), and, based on that, enter and clear a building.

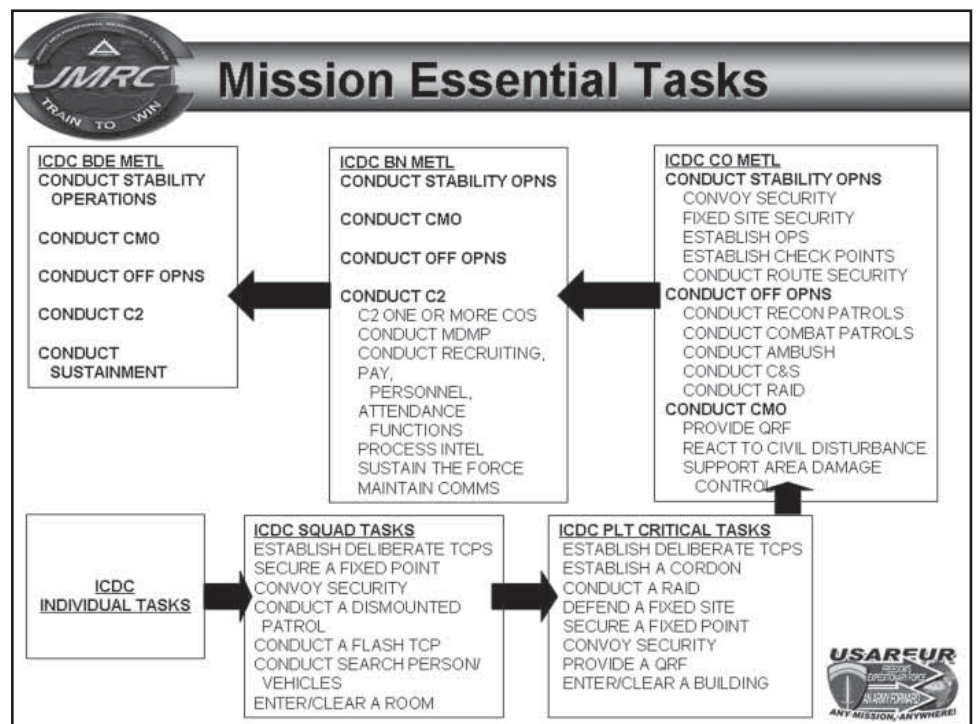

SLIDE 15

Again, I say we had modest expectations at first (Slide 16). When we sat down and said, “Okay, how are we going to do this?” I’ve got all these soldiers. I don’t have access to a basic training unit. I don’t have advisors. I have what I have, and that is a single US Task Force, 35 miles from its brigade headquarters with an AO that covers 1,600 square kilometers, and a particularly violent population with access to a lot of weapons and ammunition. The bottom line is, we had to figure out how to do this out of hide, and do it quickly, and produce units that could actually perform. Our intent was to take Iraqi squads, over a course of about four months, and put them through a two week program of instruction to take them from being a collection of individuals to being a squad that could perform eight tasks under direct supervision of a US patrol. Knowing that after that, we would start to work on our platoons moving towards November.

A couple of key things that happened out there. There’s this thing called local control. And this is a buzz word that was produced somewhere in the headquarters much higher than mine, but the intent was, by 1 October, you’ll be able to establish local control. And to this day I’m not sure what that actually meant, other than the fact that we were supposed to be able to put Iraqi Security Force units out in sector

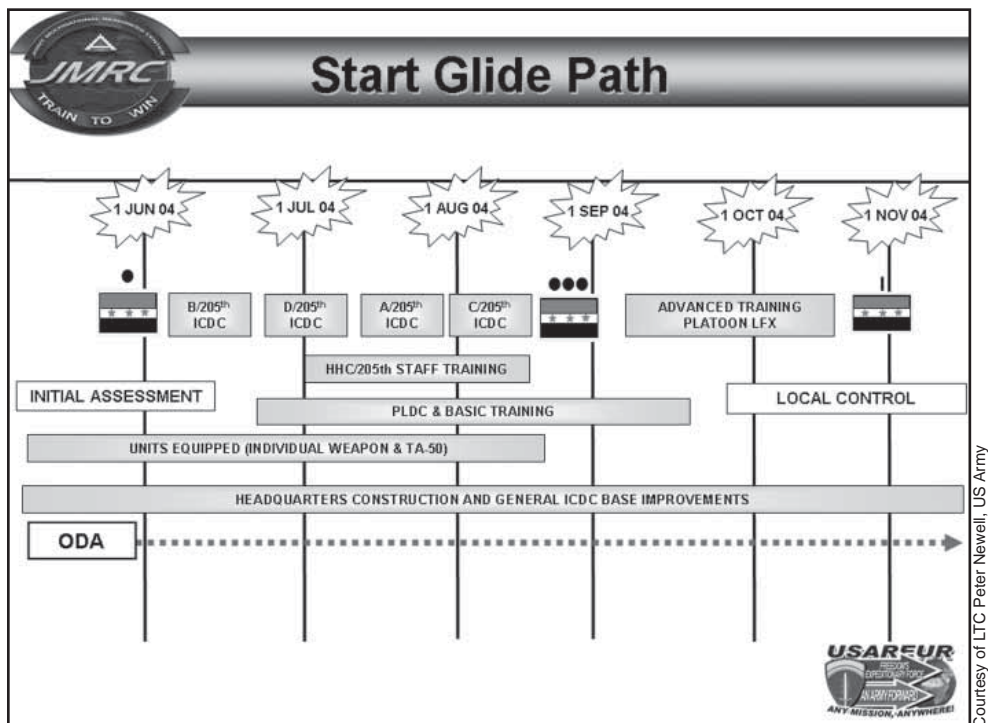

SLIDE 16

who could operate under their own direction and control without being coupled to the US patrol.

We were given access to the 1st Infantry Division's PLDC and basic training, although that only lasted one course for us. About the same timeframe, Samara became an issue for the division. They lost an entire ICDC battalion and had to rebuild it. So the slots that would typically have gone to us in this area were essentially constrained. I was able to put 30 soldiers through the PLDC course, and that became the core of success for these squads, because those guys now understood how to be an NCO. When we plugged them back into this training, they were exceptional at moving that along.

We started to get equipment, slowly, a lot of it. Again, I pulled out of the MEK storage bins as I found things. We also ... the brigade had instituted rewards for weapons. I have to be careful how I call it, but it is not a weapons buy-back program. But it is you find it, you bring it to us, we'll pay you for it. I mentioned ... let's just say I spent 3/4 of the brigade and the division's budget for this program in less than three weeks. And I bought enough weapons to outfit not just my battalion, but most of the brigade and part of the divisions. Exceptionally successful from our standpoint, because it enabled us to put guns in the hands of the guys and they quit running around with sticks as weapons.

Along in here we started getting money for construction. The construction program itself was a win-win for us. I got better facilities, but I was able to put Iraqis to work. When I arrived at my FOB, there were three Iraqis that worked there and they were all three interpreters and nobody else was allowed in. By the time I left, the FOB employed over 600. That doesn't include the 900 soldiers who moved into the FOB. A significant economic impact on the surrounding community, but that's 600 families that were taken out of the insurgency fight.

When we ended ... I'll tell you that we started out with somewhat basic expectations of what we were capable of doing, but January, February and March, our last three months in theater, we had completely graduated every company through the initial course (Slide 17). We had most of the platoons back through a second ... what we called advanced training, where we brought them in for a week at a time and did nothing but live fire, react to contact drills, and taught more leadership.

Thear, in discussions with him, continually pointed out that what he wanted were leaders that were like mine. And what he meant is he wanted junior leaders who could make decisions and perform without being told exactly what to do. Our mechanism for that was to create essentially what we called the Iraqi Infantry Officer Basic Course (IOBC). It was a two-week Plan of Instruction (POI), where we would bring those guys in and we would talk the tenets of leadership, just like we teach our own guys, but a much condensed version.

We didn't leave the staff out. We had continually worked on the staff, but we had also taken advantage of one of the early Multinational Security Transition Command – Iraq (MNSTC-I) ... I apologize because I don't remember the name

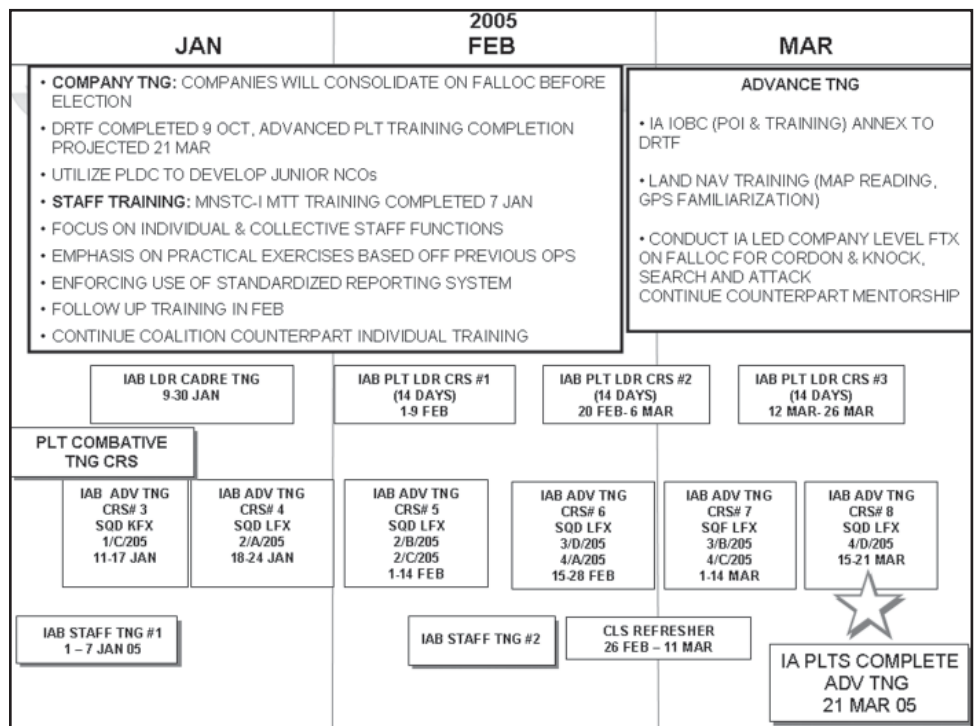

Courtesy of LTC Peter Newell, US Army

SLIDE 17

of it, but the staff training groups that came in and augmented our relationship between staff guys with this group of people who can actually come in now and run a staff exercise without pulling my entire staff out of the fight to do something.

Combat Lifesaver Training. We had conducted much earlier, but it was on the books to start again, and had a point where our battalion would be done with this platoon training here. Simultaneously, we were running platoons from the entire brigade, four at a time, through the Diyala Regional Training Facility, which is an expanded concept of what we had done here.

Training Parameters (Slide 18). This is what we walked into the school. The first is two platoons at a time on the FOB. That's fixing that airplane while it's in flight. I'm still fighting an insurgency, and I have a task force that's not big enough to cover the entire AO. We think that we could afford to pull two platoons at a time, and it was worth the commitment and the risk to get them trained and back into the fight.



## Training Parameters

Rotate two platoons at a time onto FOB Normandy for two weeks (also includes IPF). **On completion platoons partner with US companies for two additional weeks**

Rotate unit through stations. **ODA run critical stations with only one squad at a time**

Initial focus on individual skills with a strong emphasis on BRM and advanced marksmanship

Establish core competencies in platoon level tasks

**Establish an Iraqi cadre capable of continuing training without Coalition Forces support**

Remainder of 205<sup>th</sup> companies focus on sector/checkpoints. Checkpoints are manned as required/feasible



Courtesy of LTC Peter Newell, US Army

SLIDE 18

On the completion of this training, those platoons, after 14 days of training, were coupled with a US company for two additional weeks. It wasn't just about doing a Coalition patrol for the sake of doing a Coalition patrol. It was for that platoon to go through the operations order, the rehearsal, the pre-combat checks, and the After Action Review (AAR) at the end of the patrol. That's where the learning took place.

I talk about a green book winning the war, and about how part of the difficulty is convincing your own soldiers to make that kind of commitment to a force that they don't know whether they're insurgents or they're not. In my case, it was won by a green book. I don't know that anybody's ever seen an Officer Candidate (OC), tends to walk around with a green book all the time. About the second time we put a platoon out there with our forces, the platoon leader showed up, got his instruction, got his order, went through rehearsal and went away. The next day he came back, he had a green book in his hand. And the soldiers, without seeing anything, understood that he was truly committed to being like the rest of the Americans around him. He sat there, instead of writing front to back, he's writing back to front. But the bottom line is, these green books turned up all over the FOB. And every time you ran into an Iraqi platoon leader, out of his cargo pocket came his book, and he would start taking notes. That is a by-product of this partnership between the US companies. And it's an intangible. It's not something I ever expected to see, or ever said, "Make sure you get a green book and take notes." But it is a matter of them truly wanting to adopt the same procedures that we used.

The ODA. I was fortunate to have an ODA on my FOB all the time. The 1st Infantry Division Commander's guidance to us and the ODA was that 75 percent of their effort would go into training Iraqi Security Forces. For us, that meant out of this two week process, that these guys would take one squad at a time and focus on basic rifle marksmanship (BRM), advanced rifle marksmanship and room clearing so that they could focus it almost at one instructor to three students ratio to teach those critical skills repetitively over the period of two weeks. We had lots of time on BRM.

The other key is this Iraqi cadre, and I'll talk about it. I don't have the ability to train 800 guys in four months, and fight an insurgency at the same time. But I also understand, having spent some time in Kosovo and a number of other countries, that when an American tries to teach a concept through an interpreter to somebody else, only about 30 percent of that takes. If you expend some effort up front and train the interpreter first on the concept and get the best way to get it across, and then find the locals and have him train the locals to teach a concept, your 30 percent now goes to about 90 percent because it's taught in terms that they understand,

in the same language. We were committed to creating this entity, essentially a Military Professional Resources, Inc. (MPRI) set of contractors to run this school for us. Finally, we kept the remainder of the task force out in sector.

I'll talk about this cadre because it's hugely important (Slide 19). Formerly military guys hired as contractors. I wanted to escape the "I'm an ex-general, therefore everybody does everything I want." I wanted guys who had open minds and could somehow adapt US training methodology to the former British/Iraqi system of training. And that's somewhat difficult to get across, particularly when you start talking about training NCOs fire maneuver and things like that. Screened them for their ability to understand the concepts and teach. They had to actually go through the course. And I'll tell you, that weeded out half of them right there. They had to physically graduate from this course before we would even discuss whether or not they would be able to continue on as an instructor. We also looked for a broad base of guys. I wasn't just after my fan club.

This is Hassan, right here, the ringleader of my cadre. He gets it, and I have no problem with this statement at all. He said, "I love the fact that you're doing

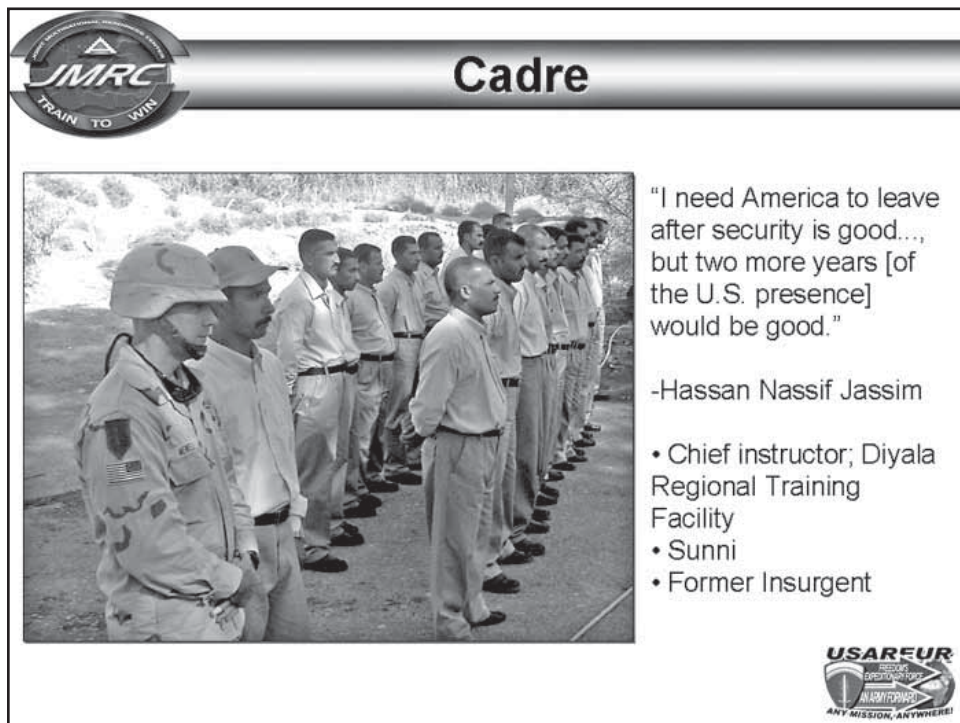

**JMRC**  
TRAIN TO WIN

## Cadre



"I need America to leave after security is good... but two more years [of the U.S. presence] would be good."

-Hassan Nassif Jassim

- Chief instructor, Diyala Regional Training Facility
- Sunni
- Former Insurgent

**USAREUR**  
REGIONAL EXPEDITIONARY FORCE  
AN ARMY FORWARD  
ANY MISSION, ANYWHERE

Courtesy of LTC Peter Newell, US Army

SLIDE 19



this for my country. I don't want you here. You're my brother. I want America to go away." And they have no problem separating these two concepts. Hassan is a former insurgent. An admitted former insurgent, who, under Thear's encouragement, said, "I'm ready to quit and come work because I'm ready to do this for my country." Not for the Americans, but for my country. And he turned out to be the biggest cheerleader of the Diyala Regional Training Facility. Hassan, himself, was probably able to ratchet down the violence in the AO by 10 to 15 percent just by his presence on the FOB. People started to realize that it was okay to have a difference of opinion, but that this really was about the country, and not about the Americans.

The program of instruction (Slide 20) for the 14 days for the initial .. and again, I talk about before you shoot guns, you got to teach first aid. We spent some time teaching basic first aid. We started out, and here we are, US instructor, trying to explain to an interpreter how to do something, who then tries to explain that same concept to a group of people. It takes three times as long to teach a basic task this way than it does just to train this guy to do first aid and have him teach the class. We finally broke that phalanx, eventually.



## 14 Day POI – Individual Tasks

Day 1 - Basic First Aid  
Chain of Command Class

Day 2 - BRM/CQM  
IMT- as a team  
Hand & Arm Signal / Movement Formations Class

Day 3 - BRM/CQM  
IMT – as a team  
Hand & Arm Signals/Movement Formations Class

Day 4 - BRM/CQM  
Map Reading (Leaders only)  
Report Enemy Activity  
Handle enemy personnel

Day 5 - BRM/CQM  
Map Reading (Leaders only)  
Report Enemy Activity  
Handle enemy personnel



Courtesy of LTC Peter Newell, US Army

SLIDE 20

A lot of focus on basic rifle marksmanship, close quarters marksmanship, IMT, and basic movement stuff here. We also spent some time doing map reading with the NCOs. This is an NCO-driven course. We were very focused on the squad leaders and determining who they were going to be.

Team and squad efforts (Slide 21). The most highly technological training I ever employed in Iraq was a green army man. And more than one fist fight was started over a tactical discussion with green army men on top of a cot. It's not difficult. Doesn't take a PowerPoint presentation, but it does give these guys a tactical problem, and allow them to talk through it. You'd be amazed at what you get back. And again, the problem teaches itself, and these guys, given a problem, will rise to the challenge and play every step of the way.



## 14 Day POI – Team / Squad

  

Day 6 – Close Quarters Battle (CQB) / Enter and Clear Room  
Movement Formations/Principles of Patrolling P.E.  
Movement Techniques

Day 7 - CQB / Enter and Clear Room  
Movement Formations/Principles of Patrolling P.E.  
Movement Techniques

Day 8 - CQB / Enter and Clear Room  
React to Contact  
React to Contact

Day 9 - CQB / Enter and Clear Room  
React to Contact  
React to Contact



Courtesy of LTC Peter Newell, US Army

SLIDE 21

Lots of focus on close quarter battle, movement techniques, and reactive contact, enter and clear a building, and QRF (Slide 22). Here's an NCO. You notice, hands are in the right places, fingers off the trigger, finger next to it, the safety is on. Hand on the back of the guy behind you. This is nothing more than a tape drill ten days into this course. These guys were truly the focus of our efforts.



## 14 Day POI – Platoon

Day 10 - Enter/Clear a Building

Day 11 - Enter/Clear a Building

Day 12 - Establish TCPs  
Secure/Defend a Fixed Site

Day 12 - Establish a Cordon / Conduct a Raid

Day 13 - Establish a Cordon / Conduct a Raid

Day 14 - Provide a QRF  
Provide Convoy Security  
After Action Review



Courtesy of LTC Peter Newell, US Army

SLIDE 22

Leader training (Slide 23). And I talk about ... one of the cultural differences between training a US company and training somebody from the Mid-East, one is the number of hours in a day you work, and when is the right time to teach something that's difficult? We spent a lot of time talking leadership. And this was Brian Ducote, Sergeant Major Bohn, myself, and Colonel Thear, personally standing in front of you, each one of these platoons, talking particularly the ICDC creed, the role of the NCO, leadership, and troop leading procedures. This is also where Thear started to pick his squad leaders. As we started to make an assessment of people and as he started to discuss with these guys and get feedback, he would walk out on graduation day and pull the guy to his side and say, "You're now a Private." And grab a guy and say, "You've demonstrated the ability to lead a squad. You are now the squad leader." So what he got at the end of this 14 day POI were a set of leaders in each one of these platoons who truly demonstrated the ability to lead. Now, they weren't done yet, by any means. They still needed a lot of mentoring, coaching, and somebody sometimes disciplining them to actually perform. But what he got was the core of a battalion.



## 14 Day POI – Leader Training

Each night the Platoon Leaders and NCO's participated in leader training. The ING Cadre (US) and the 205<sup>th</sup> Battalion commander all lead classes; both in and out of the classroom

- Hip Pocket Training
- ICDC Creed
- The role of the NCO
- The role of the Platoon Leader
- Leadership
- TLP
- Role of the Staff
- Leadership TTPs
- Fitness



Courtesy of LTC Peter Newell, US Army

SLIDE 23

I'll flip through a lot of pictures (Slide 24). I won't say that we did not leave enough alone just to teach squads. Didn't have advisors, but every one of my staff officers had a role in training his counterpart. Captain Mitchell, who obviously looks like he's just come off his eight hour shift in the Tactical Operations Center (TOC) is, in fact, on his second four hour shift, now training his Iraqi counterpart down in the Iraqi TOC. One of the initial decisions we made that allowed this stuff to happen is we moved the Iraqi battalion headquarters 200 yards away from mine, and took the risk of bringing them on to the FOB. We built them a headquarters using what we called Petraeus money, and brought them there to live. Outfitted it just like ours. Satellite imagery, maps, radios, the other things that they would need to do their job, to create an environment just like ours. My staff officers, when they were not on shift, had the requirement to spend x number of hours a day with their counterpart training. A lot of it was drive-by training. You know, I don't have anything else scheduled today, I'm just going to walk down the street and check on my guys. And that's how they described them. My guy. And there was a lot of pride in how this went along.

 <b>TF 2-2 DAILY DRUMBEAT</b> (30 AUGUST 2004)			
			
<b>LOO: SECURITY</b> <b>WHO: TF 2-2 AND 205<sup>TH</sup> ING BN BATTLE CAPTAINS</b> <b>WHERE: 205<sup>TH</sup> BN HQ (FOB NORMANDY)</b> <b>WHEN: 30 AUG 04</b> <b>WHAT: INSTRUCTION IN THE SIX TOC FUNCTIONS AND 3 ASPECTS OF INFORMATION MANAGEMENT</b> <b>WHY: BUILDS BASIC STAFF COMPETENCIES AND DEVELOPS MUTUAL TRUST BETWEEN IRAQIS AND US SOLDIERS</b>			

Courtesy of LTC Peter Newell, US Army

SLIDE 24

This is the staff interpreter. This guy did nothing but staff trainer. He was trained by our guys, initially, in the concepts, and he accompanied every one of the staff officers when they were required to do this training. We get an interpreter who understands the concepts and he understands what's going on in the battalion. I don't want to call the guy a mole because he spends a lot of time down in that battalion, so he has the ability to come back and tell his US counterpart, "Hey, after you left, here's what happened, and here's what the discussion really was." Okay, I didn't understand the question or I didn't do it right, or I confused him more than I helped him.

This is the company commander doing a back brief for a convoy live fire, or a combat logistics patrol live fire (Slide 25). In conjunction with his counterpart company commander. These are both the headquarters commanders. You'll note he's doing the briefing, he's not. At the head of the table, Colonel Thear, myself, Captain Ducote, Sergeant Major Bohn, all present in the room. But it is a matter of teaching them how to bring training systems together and how to get these leaders to actually put together an event, work through it, and show some initiative and do it. This officer would eventually become the battalion S-3. Proved to be excep-

 <b>TF 2-2 DAILY DRUMBEAT</b> (11 OCTOBER 2004)	
	
<p><b>LOO: SECURITY</b>  <b>WHO: 205<sup>TH</sup> ING BN AND TF 2-2</b>  <b>WHERE: FOB NORMANDY</b>  <b>WHAT: THE COMMANDER OF HHC/205<sup>TH</sup> ING CONDUCTED HIS BACKBRIEF FOR THE UP-COMING CLP LFX THAT THEY WILL EXECUTE WITH ELEMENTS OF HHC/2-2 IN</b>  <b>WHY / SIGNIFICANCE: THE BACKBRIEF IS ACCORDANCE WITH THE 8-STEP TRAINING MODEL. THE ING'S PROFICIENCY WITH TRAINING MANAGEMENT AND THEIR PERFORMANCE IN A JOINT LFX DEMONSTRATE THE MATURITY THAT WILL LEAD TO LOCAL CONTROL</b>  <b>BULLETIZED: HHC/205<sup>TH</sup> ING CONDUCTS BACKBRIEF TO THEIR BN CDR CONCERNING UP-COMING CLP LFX</b></p>	

Courtesy of LTC Peter Newell, US Army

SLIDE 25

tional character, a lot of integrity. A lot of effort put in to training his soldiers, and truly wanted to be a success story.

I talked about Combat Lifesaver Training (Slide 26). And yes, this is an American soldier with an Iraqi soldier sticking a hypodermic needle in his arm. Learning how to do IVs. It's a demonstration of trust and desire. That's when you truly know you've beaten the story with your own soldiers, is when they're willing to allow that to happen. But they did. My medics, exceptionally proud of the fact that they were able to put their Iraqi counterparts through the US 40-hour Combat Lifesaver Course. They issued them the same certificates that our guys carry. And they were able to perform this on call anywhere they needed to.

 <h2 style="text-align: center;">TF 2-2 DAILY DRUMBEAT</h2> <p style="text-align: center;">(16 OCTOBER 2004)</p>	
	
<p> <b>LOO:</b> SECURITY  <b>WHO:</b> 205<sup>TH</sup> ING BN  <b>WHERE:</b> FOB NORMANDY  <b>WHAT:</b> 205<sup>TH</sup> ING BN AND TF 2-2 MEDICS CONDUCTED COMBAT LIFESAVER INSTRUCTION  <b>WHY / SIGNIFICANCE:</b> TF 2-2 MEDICS GRADUATED 14 ING SOLDIERS FROM THE ONE WEEK COURSE. THEIR SUCCESS IMPROVES THE FIGHTING PROFICIENCY OF THE 205<sup>TH</sup> ING BN AND CONTRIBUTES TOWARD LOCAL CONTROL.  <b>BULLETTIZED:</b> TF 2-2 AND 205<sup>TH</sup> ING BN CONDUCT CLS TRAINING.         </p>	

Courtesy of LTC Peter Newell, US Army

SLIDE 26

Chaplain didn't get out of it either (Slide 27). The chaplain had an Imam counterpart, who they spent time talking about religious support and how we've got to manage that.





## TF 2-2 DAILY DRUMBEAT

(2 OCTOBER 2004)





**LOO: SECURITY**  
**WHO: 205<sup>TH</sup> ING BN**  
**WHERE: FOB NORMANDY**  
**WHAT: 205<sup>TH</sup> ING BN CHAPLIN, TOGETHER WITH THE TF 2-2 CHAPLIN CONDUCTS SPIRITUAL LEADERSHIP STAFF TRAINING**  
**WHY / SIGNIFICANCE: THIS TRAINING INSTRUCTS THE 205<sup>TH</sup> IMAM ON THE UNIQUE REQUIREMENTS OF A MILITARY SPIRITUAL LEADER AND FURTHER UNIFIES THE PARTNER BATTALIONS.**  
**BULLETIZED: TF 2-2 AND 205<sup>TH</sup> ING BN CONDUCT CHAPLIN TRAINING AT FOB NORMANDY**

Courtesy of LTC Peter Newell, US Army

SLIDE 27



Rebuilding the Iraqi Army. And I'll tell you, it's more than just buildings. But it is a matter of systems, and a story ... I'll talk about systems. But more importantly, building confidence. Not only in themselves, but the confidence in the Iraqi people to believe in them.

Again, this is Petraeus money (Slide 28). This is MNSTC-I, my division commander, people who came to visit the FOB and saw what we had to do, and were willing ... I don't want to say accept some risk, but willing to put the money out there that would allow us to be successful.



## Re-building Falloc

PROJECT	STATUS	PAYMENT CONDUCTED	COST
4 X IAB BILLETS/ JAIL/ small HQ bldg (6 bldgs)	COMPLETE-27 Jan	100%	\$500,000
8TH MECHANIZED BRIGADE/BN HEADQUARTERS BUILDINGS (6 bldgs);	IN PROGRESS/ 95% complete	50%	\$500,000
205 <sup>th</sup> IAB DINING FACILITY FOOD	EXTENDED TO AUG 05	50%	\$1.2 MIL
HHC/205 <sup>th</sup> IAB and POLICE ACADEMY	45%	50%	\$485,000
205 <sup>th</sup> IAB INTERNET	APPROVED	Awaiting response from contractor for installation	\$112,000
IAB MAINTENANCE FACILITIES (2 x parking areas and 1 bay)	SUBMITTED 31AUG04	At comptroller	\$468,000
3 <sup>rd</sup> "\$500K" PROJECT- IOBC Academic building and 3 x barracks SE of jail	SUBMITTED 24JAN05	None	\$500,000
4 <sup>th</sup> "500K" PROJECT- barracks compound SW of previous 8 <sup>th</sup> Mech BDE HQ	SUBMITTED 24JAN05	None	\$500,000

Courtesy of LTC Peter Newell, US Army

SLIDE 28

The Iraqi Army billets. J. L. Small headquarters. Half a million dollars, completed on 27 January. That allowed us to move that entire battalion, who up to that point ... you don't understand. I talk about that 24 on, 24 hour thing. We were never able to break that until we were able to move them into their own barracks. These guys all live at home with their families, and have to assume the risk of driving back and forth to work with people knowing that they're Iraqi soldiers. I can't tell you how many of my own soldiers, my Iraqi soldiers, were ambushed on the way home for relieve, or on their way back to work, only because they lived out in what we considered Indian country. So if you wanted these guys to perform, and you wanted them to train, we owed them this. We owed them a place to go.

Thear. One of the most important things I had to do was keep Thear alive. I could tell you, you get a guy like Thear who proves to be exceptional in his job, he is the first guy somebody wants to kill. They'll take him off the map. I literally moved Thear and his family onto the FOB in June of 2004. Found them a building, gave them the money and renovated the building and put him in it. And then I made sure that when he left the FOB, he adopted the same security procedures that I did. Actually gave him a set of body armor and ensured that he survived this process. He was the high value target (HVT) of my AO. More so than any of the political leaders.

The 8th Mechanized Brigade, battalion headquarters. This is a concept that we started, ostensibly to build this armored brigade for the Iraqi Army that eventually ended up in Baghdad. But the money didn't get shut off, and today is in good use. There's actually another Iraqi Army battalion living on here. But more importantly to me, it's a half a million dollars ... that was 100 jobs for soldiers. And a great deal of pride with the civic leaders. I'll show you some pictures here of the opening ceremonies for a number of these compounds. You'd be surprised at the number of tribal leaders who were willing to come to a US base ... what was a US base, that is now half Iraqi. It was like opening the flood gates. Now we're talking interaction with everybody. Lots of people who were willing to come and interact with us, not just engage with us, but interact with us.

We figured what worked with the Iraqi Army battalion would work with the Iraqi Police Service (IPS), so we decided to build the Diyala Regional Iraqi Police Training Facility. Only moderately successful, for different reasons. Internet access, maintenance facilities, the Infantry Officer Basic Course (IOBC), which was the addition to the Diyala Regional Training Facility, and then finally more of the 8th Mechanized Brigade headquarters. This would eventually be built as the 32d Iraqi Army (IA) Brigade Headquarters, and actually taken over. But a considerable amount of money put into rebuilding FOB Normandy, which is now called Falaq, which was its original name.

Ribbon cutting ceremony for Thear's headquarters (Slide 29). This is then Major Thear and this is the mayor. You'll notice that the US Task Force Commander—me— doesn't have his hands anywhere in this pie. This is about them, it's for them. It's their thing. The guest list. Every single one of the major tribal leaders, mayors, the assistant division commander, the brigade commander, Thear, and lots of family members and soldiers. What you can't see is there are another 200 people over here that have come to see this event. And this is on what is a US base, literally 150 meters from my headquarters.

**205<sup>th</sup> ING HQ RIBBON CUTTING CEREMONY**  
(19 AUG 04)



- LTC THEAR IS JOINED BY THE MUQDADIYAH MAYOR FOR THE RIBBON CUTTING
- CEREMONY MARKS THE COMPLETION OF A \$200,000 HEADQUARTERS COMPLEX THAT BEGAN IN JUL 04
- IN ATTENDANCE WERE THE MAYORS OF MUQDADIYAH, WAJIHIYAH, THE MUQDADIYAH DISTRICT TRIBAL LEADERS, THE DIYALA GOVERNOR, BG MORGAN, COL PITARD, LTC NEWELL AND SOLDIERS OF THE 205<sup>TH</sup> ING TIGER BATTALION



Courtesy of LTC Peter Newell, US Army

SLIDE 29

Talked about inviting the press and engaging the press (Slide 30). This is Al Jazeera at that opening ceremony. You think that we had problems with Al Jazeera. When I told Thear and the mayor of Muqdadiah that they were coming to this event, Thear said, "No. Not only no, but hell no." The mayor went so far as to say that, "I'll have them met at the end of the city. I'm going to cut their heads off and put it on a stake at the end of the city so that they never come back." There's a challenge there. Not only do I have to get my guys to talk to these, but I realized, only halfway kidding, that somebody's liable to shoot these guys before they get there. We did. They came, they saw, they did a fairly decent article. Convincing our guys to actually sit down and interview was difficult, and it's one of the few occasions where I looked at Thear and said, "I'm tired of talking about this. You're going to do it. Trust me." And if I say, "Trust me," this is your uncle now talking to you saying, "This is a good thing, and we'll talk about it later."



## 205<sup>th</sup> ING RIBBON CUTTING CEREMONY

(19 AUG 04)





- INCLUDED AT THE CEREMONY WERE MEMBERS OF THE ARABIC PRESS, NOTABLY AL JAZEERA AND ASSOCIATED INTERNATIONAL PRESS
- THE REPORTERS WERE PLEASED WITH THE CEREMONY AND WITH THE PARTNERSHIP BETWEEN TF 2-2 AND THE 205<sup>TH</sup> ING BN.
- AS COL PITTARD REMARKED, "THE PEACEFULNESS OF THE MUQDADIYAH AREA IS THE RESULT OF THIS PARTNERSHIP"
- POETRY WAS READ BY A YOUNG GIRL WHICH STRESSED THAT THE REBUILDING OF THE 205<sup>TH</sup> ING HQ IS SYMBOLIC OF THE REBUILDING OF IRAQ







Courtesy of LTC Peter Newell, US Army

SLIDE 30

A lot of this is get these guys inside (Slide 31). A great deal of pride in what they saw, both in terms of the capability of the Iraqi Security Forces.



Conclude this thing with the governor giving out awards for bravery, which usually involved a certificate and cash. They don't do medals very often, but they do cash bonuses for things. A very important event, because lots of the family members standing by, seeing the Iraqis were rewarding themselves for fighting the counterinsurgency, not a US guy standing up there doing this.





## 205<sup>th</sup> ING RIBBON CUTTING CEREMONY

(19 AUG 04)





- 205<sup>th</sup> BN CDR, LTC THEAR, SHOWS HIS NEW TOC TO THE MAYOR OF MUQDADIYAH, BG MORGAN, AND COL PITTARD
  
- LTC THEAR AND GOVERNOR ABDULLAH PRESENT THE 205<sup>th</sup> ING SOLDIERS AWARDS FOR THEIR PARTICIPATION IN THE CAPTURE OF MR. GHANIA SHELISH ON 11 AUG 04 (HVT #1 IN MUQDADIYAH REGION)



Courtesy of LTC Peter Newell, US Army

SLIDE 31

Systems. It's a busy chart (Slide 32). What you see here are Iraqi checkpoints in gray, and base stations where we installed radios in July of 2004. I say this is important because I got into a very heated argument with my own company commanders in early June. A checkpoint manned by the Iraqis, ostensibly to curb the flow of Improvised Explosive Devices (IED) and other things moving through Muqdadiyah, was attacked by small arms firing RPGs and the Iraqi soldiers abandoned their checkpoint. My company commander who came into the FOB livid, "Can't trust these guys. Don't know why we're doing this." And on and on. And we had a long discussion about, "Okay, let's talk about the soldier that is standing at this checkpoint, who has no phone, can't call for help, he has no helmet. No body armor, and one magazine of ammunition and no RPGs. Tell me again why he runs away every time somebody shoots at him. What incentive does he have to stay?" This was huge. If we ever wanted to beat this thing, we had to find a way to talk. Talk to the checkpoints, talk to the patrols that were on the ground. So prior to anybody providing us money, we actually whipped this out of our budget for the IA, knowing that this was what was going to get us through the insurgency early on, was the ability to talk to these guys. We lost five guys at this checkpoint. Five Iraqi soldiers who were ambushed in a fire fight, shortly after we decided to

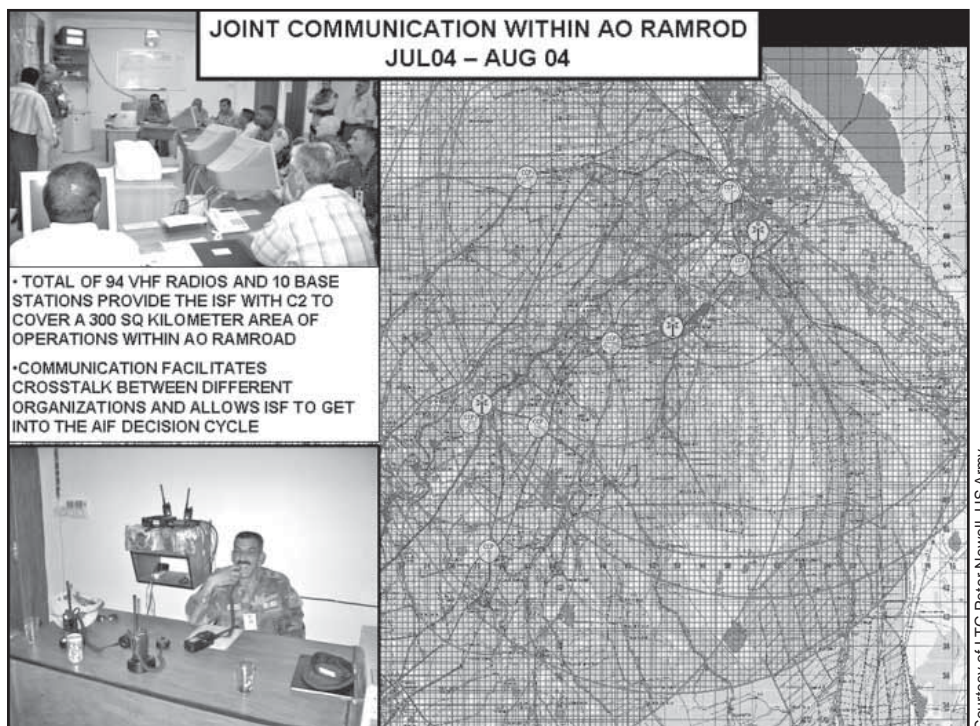

SLIDE 32

do this buy and before we had the radios. I will tell you, once the radios went in, it never happened again. And we got to the point that if somebody shot at these checkpoints, the Iraqi QRF would make it there faster than my guys would, unless they were sitting right there. Communications, as much as being able to shoot a rifle, is hugely important.

We also talked about the body armor thing and the helmet thing and the other vehicles. It was night and day of my own commander, starting to realize that the commitment of the Iraqi Army soldier who was accompanying them on a patrol was much greater than their own. Again, we go back to the green book thing. But now my commanders are coming to me complaining that their Iraqi soldiers don't have enough equipment. And that's exactly how they said it.

Diyala Regional Training Facility (Slide 33). This one is huge. This is the only time I ever put my hand on a ribbon. This is the governor of the province, who lived right outside the FOB, by the way, Thear, his daughter, the mayor, General Batiste, my Kurdish S-3 of the battalion, all walking through the Diyala Regional Training Facility. And the start of the construction for these Iraqi Army barracks.

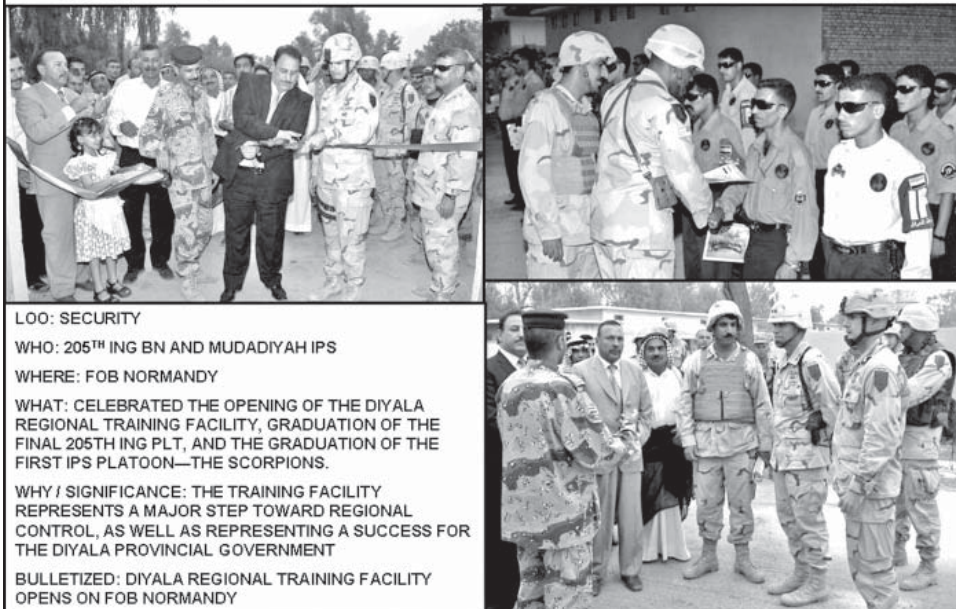
 <b>TF 2-2 DAILY DRUMBEAT</b> (9 OCTOBER 2004)	
<p>LOO: SECURITY</p> <p>WHO: 205<sup>TH</sup> ING BN AND MUDADIYAH IPS</p> <p>WHERE: FOB NORMANDY</p> <p>WHAT: CELEBRATED THE OPENING OF THE DIYALA REGIONAL TRAINING FACILITY, GRADUATION OF THE FINAL 205TH ING PLT, AND THE GRADUATION OF THE FIRST IPS PLATOON—THE SCORPIONS.</p> <p>WHY / SIGNIFICANCE: THE TRAINING FACILITY REPRESENTS A MAJOR STEP TOWARD REGIONAL CONTROL, AS WELL AS REPRESENTING A SUCCESS FOR THE DIYALA PROVINCIAL GOVERNMENT</p> <p>BULLETIZED: DIYALA REGIONAL TRAINING FACILITY OPENS ON FOB NORMANDY</p>	

Courtesy of LTC Peter Newell, US Army

SLIDE 33

And again, it reflects a huge commitment on the part of US forces to build this base for this battalion and the brigade.

Confidence building (Slide 34). Here is the headquarters company commander again. Part of that advanced training, live fire, out in the open desert. Over and over and over again. In an AAR, not conducted by a US officer, but conducted by an Iraqi Company Commander. He's training his soldiers. There's a little bit of English up there, but everything else is in Arabic. They proved to be exceptional at it. The soldiers themselves, funny. They respond just like every other soldier I've ever met in any other Army. If you give them challenging training and you give them weapons and bullets and things like that, they respond to it, just like ours do.

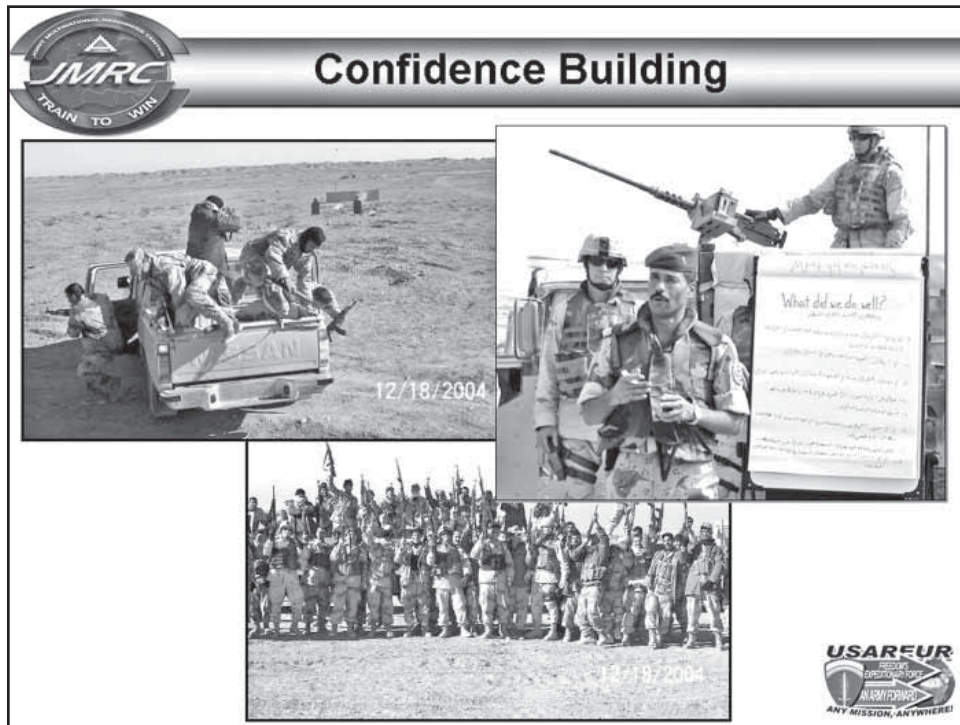

Courtesy of LTC Peter Newell, US Army

SLIDE 34



The rehearsal prior to the elections (Slide 35). This is an Iraqi Security Force, Thear run operation. The terrain model, built by his soldiers. My company commander is in attendance, his company commander, the Iraqi Police, and the Joint Command and Control (JCC) crew. All run by Iraqi Security Forces. I'm a note taker. You notice my green book. Thear, his green book. Neck and neck the whole time. That's confidence. Not once during the process of four rehearsals did I ever have to stand up and redo a concept of what they were doing. They worked this one to the end of the election. And as I mentioned earlier, on the day of the elections, despite 34 attacks on polling positions, there was not a single case of a US force having to respond to one of those attacks. In every case, the Iraqi Army or the police first stood their ground, then second responded to those attacks on their own.

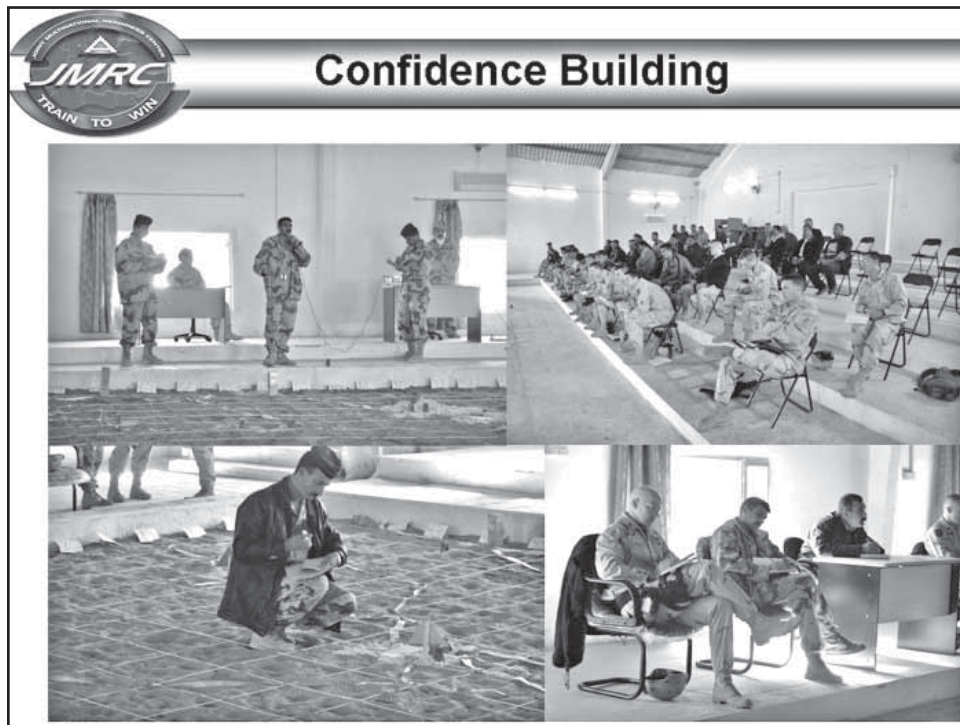

SLIDE 35

Courtesy of LTC Peter Newell, US Army

Sometimes it's about what you don't do (Slide 36). This is the mosque next to Thear's headquarters. His headquarters is right here. When I activated this FOB, this mosque was actually used by the task force previous to me as a dining facility for the company that worked here. Inside was any amounts of graffiti. There were lots of issues with this thing. I mentioned to Thear when he occupied his headquarters that I looked forward to the day that I could hear a call for prayer at his mosque. I did nothing else. I didn't provide him any money, didn't provide him any incentives ... I didn't provide anything. One evening, these soldiers showed up at my headquarters and said that Colonel Thear would like me to come down to his headquarters to talk with him. When I arrived, the Iraqi ... or actually, my JCC director, the mayor of Muqdadiah, and Thear were waiting at the entrance to the mosque for me. And it's the one and only time that I ever set foot in a mosque. But they wanted to show me what they'd done to the inside of the mosque. And this collection of soldiers, using their own funds and their own means, had gone in and completely gutted the mosque and rebuilt it and opened it again. The next morning, bright and early, was the first call for prayer across Falaq. And it happened every day after that. Why do I say confidence building? I never did this. This was all about them using their own means for themselves. And it was a demonstration of

	<h2>TF 2-2 DAILY DRUMBEAT</h2> <p>(15 OCTOBER 2004)</p>	
<p><b>LOO: SECURITY</b>  <b>WHO: 205<sup>TH</sup> ING BN</b>  <b>WHERE: FOB NORMANDY</b>  <b>WHAT: 205<sup>TH</sup> ING BN OPENED THEIR MOSQUE, LOCATED IN THEIR BATTALION AREA ON FOB NORMANDY.</b>  <b>WHY / SIGNIFICANCE: THE MOSQUE AFFIRMS THE COMMITMENT MADE BY THE COALITION FORCES TO RESPECT THE RELIGIOUS BELIEFS OF THE ING . ADDITIONALLY THIS SUPPORT WILL IMPROVE RELATIONS IN THE MUQDADIYAH COMMUNITY FOR BOTH THE ING AND COALITION TROOPS.</b>  <b>BULLETIZED: 205<sup>TH</sup> ING BN OPENS THEIR MOSQUE ON FOB NORMANDY.</b></p>		

Courtesy of LTC Peter Newell, US Army

SLIDE 36

the fact that they were completely capable of solving something that was incredibly important to them without US help and innovation.

Bruce Padle, a representative of the Department of Justice (Slide 37). And I will tell you that in terms of systems, the justice system and how it applies to the Iraqi Army and the Iraqi Police is extremely different from anything I've ever experienced. For instance, if an Iraqi policeman shoots somebody in the line of duty, he is then put in jail with the other criminal until a judge decides whether he, in fact, fired his weapon in the line of duty or not. Tribalism, particularly in rural areas, is rampant. If somebody kills somebody else, you got two choices. You can either ... your family can own up and pay for it, or you can go to jail. Sometimes you go to jail until your family comes up with the money. My relationship with the judges in the area, I will tell you, at best was antagonistic. They saw us as usurpers because we were detaining people, putting them in a US facility, for things they saw as their purview for Iraqi crimes. In some cases, they accused us of arresting the wrong people, constantly. In comes ... Bruce Padle, who is doing some things for the Department of Justice, and actually to establish a justice system. And we saw this as an excuse to change our relationship with the judges, particularly mine. To sit down with the judges and try and figure out what our problems were.

**TF 2-2 MAINTAINS IRREVERSIBLE MOMENTUM IN THE COUNTER-INSURGENT FIGHT**

**MR BRUCE PAGEL AND THE CHIEF JUDGE OF MUQDADIYAH**

**DALI ABBAS COURTHOUSE**

**MR BRUCE PAGEL, REPRESENTATIVE FROM THE UNITED STATES DEPARTMENT OF JUSTICE, MET WITH POLICE, JUDGES, AND MUQDIDIYAH SECURITY WORKING GROUP MEMBERS TO STRENGTHEN THE TRIAD OF COURTS, JUDGES, AND PRISONS IN MUQDADIYAH, ABU SAIDA, AND DALI ABBAS FROM 24 – 28 AUGUST TO DISCUSS THE LINKAGE AND PROCEDURES BETWEEN ING, IPS, AND LAW AND ORDER. A KEY TASK FOR THE SECURITY AND GOVERNANCE LINES OF OPERATION.**

**CONFERENCE OF MUQDADIYAH JUDGES**

**ING GUARDS THE DALI ABBAS COURTHOUSE**

Courtesy of LTC Peter Newell, US Army

SLIDE 37

Thear, as a part of this, wanted to get to the point where he personally was not under the threat of the Iraqi judicial system. At this point, there's no protection for the Iraqi Army or the ICDC. The ICDC and the Iraqi National Guard is not part of the Iraqi Army, therefore technically doesn't fall under the Ministry of Defense. They're not part of the Ministry of Interior, so there really is no law that protects them in the manner of doing business. So there's nothing that says an Iraqi soldier who gets in a fight, who goes home later on, can't be arrested because some judge has been pressured by a tribal leader who was offended by what he did.

What we were able to work out, mostly with Bruce's help, is a means of Iraqi judges issuing warrants for the arrest of insurgents. What it turned out to be is Thear and two of the judges worked out arrangements so the confidential sources would not be spelled out in the warrant by name. The guy would have a number, the judge would know who the name and the number went to, but Thear had somebody he could go to with evidence, provide it to the judge, the judge would write a warrant. We would then take that warrant with us when we went to detain somebody. If the guy wasn't home, we'd leave the warrant there and give it to the tribal elders or anybody else in the town. They understood that a judge had directed the arrest of whoever. In probably half the cases, the tribal elders brought the guys to us later on that we were looking for. But again, it's rebuilding the system and the confidence in themselves. Thear now has an out because his missions with us to arrest insurgents are now covered by at least somebody who says, "Yeah, this is legal under Iraqi law." The judges now understand that we are not going out and just arresting anybody we want, but we are actually going to play a part in keeping them included in the loop. Were we ever challenged by the judges? Occasionally. Yes, sir?

#### **Lieutenant General David Petraeus**

Well, I was just going to mention, just so folks do know, that eventually the ICDC were incorporated into the Iraqi Army. In fact, on Army Day in 2005. So that issue did ... but that was a very innovative solution in the meantime.

#### **Lieutenant Colonel Peter Newell**

Yes, sir. It was significant. I don't know if the Iraqi police issue was ever solved. I think the Iraqi police still work under that assumption, if you shoot somebody, then you're going to go to ... there's a lot of incentive not to do your job as an Iraqi policeman.

Here's one of those cases where you know you've won when it happens (Slide 38). What you've looked at are what we call drum beats. Those are the things go good, we put out a drum beat, send them to our higher headquarters. Thear and his staff are doing the same thing. In fact, they're providing me a courtesy copy in English of what they're sending the Ministry of Defense. I discovered this by accident one day, as his S-1 was knocking one of these out. Again, they're great mimics, but they have the ability to take the good things that we're doing, step one step over, and incorporate it into a system that works for them.

This is the Iraqi S-1 version of ... I don't know why you're surprised that we get along so well because we're both working on the war on terrorism. That's not my words, that's the S-1 of the 205th Iraqi Army Battalion. This is after his first experience with my good friend, Jane Arraf.

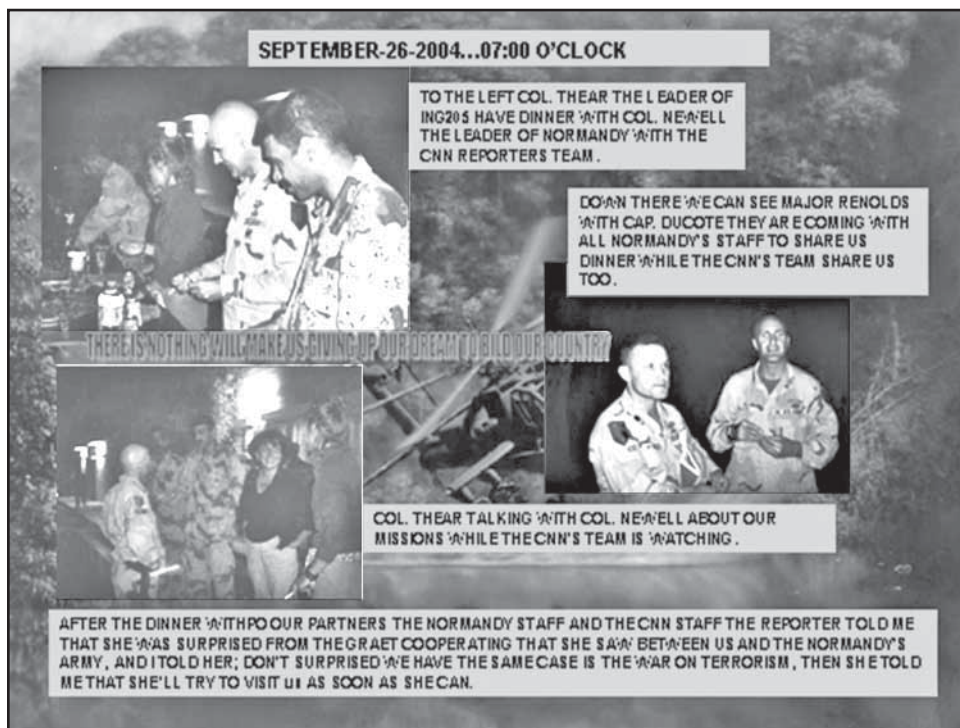

Courtesy of LTC Peter Newell, US Army

SLIDE 38



Finally, again, I talk about there's not an American present, other than the guy with the camera here (Slide 40). This is all about them doing it for themselves, providing whatever. With that, I thank you.



SLIDE 40





## **Vietnam and Iraq: Why Everything Old Isn't New Again**

(Transcript of Presentation)

**Dr. Andrew Krepinevich**  
**Center for Strategic and Budgetary Assessments**

About 20 years ago I wrote this book about the Army's experience in the Vietnam War, and the powers that be here thought it might be interesting to sort of compare and contrast. Of course, you could spend hours and hours and hours talking about this and that and how Vietnam is or isn't different from what's going on in Iraq, but that's my job, and so I've done it in kind of a selective way. So it's not comprehensive, and quite frankly, the focus is more on Iraq than it is on Vietnam, which I think is entirely appropriate.

So the questions I kind of want to address during the course of my presentation is what kind of war are we looking at? How well prepared were we for these conflicts? How did we conduct them? Or, in the case of Iraq, how are we doing so far? And then the question of a war of necessity, which I think is a very interesting and important question for us to consider, particularly at this point in the conflict in Iraq. So, that's what I'm going to talk about.

What kind of war? You can all read it. I think President Kennedy, when he talked to the graduating class at West Point in June of 1962 put it pretty darn well. He was talking more about the insurgency in Southeast Asia at the time, and Laos and in Vietnam. But again, I think the words speak pretty well to us in the new era in which we're in. Sort of the everything old is new again. "...requires in those situations where we must counter it, a whole new kind of strategy, a wholly different kind of force, and a new and wholly different kind of military training." And certainly that is what we have confronted these past few years as we've gotten back into the business of counterinsurgency, a business that essentially we left following the Vietnam War.

In a counterinsurgency war, or in an insurgency conflict, I think one of the first things you have to do is identify what are the centers of gravity? A few years ago I was involved in a discussion with a group of American Generals, and before that I had been asking people in the Pentagon, "Okay, we're in this fight. What's the center of gravity? What are we focusing our efforts on?" And it seems to me that there are three. And it's slightly different from the Vietnam experience. There's a little bit of a definition up there.

There seem to be, in my mind, three centers of gravity. One is the indigenous population, the Iraqi people. And it's very much hearts and minds. It's become a cliché, but quite frankly, it's repeated again and again because it's true. Do the Iraqi people want us to win? Would they like to see us win? That's sort of the hearts question. And then the minds question, which is do they think we're going to win? Because no matter how badly I may want you to win, if I think you're going to lose, I've got to accommodate myself to the people who I do think are going to win. So can you secure that center of gravity?

Second, the American people. When you have an external power like the United States that is a critical part of the military balance, if you want to call it, in this particular kind of conflict, and it's a democracy like the United States, then it's also the hearts and minds of the American people that are a center of gravity. And arguably, one of the reasons we did not prevail in Vietnam was we lost that center of gravity. Do the American people think that this is a war that's worth fighting? And again, do they think we're going to win? Or do they think that it's more good money, more good people ... in terms of cost, to no good effect? So the second center of gravity is the American people.

And the third is the American soldier. During the Vietnam War, if we needed more soldiers, we increased the draft call. We can't do that this time around. So the question is, can we recruit and retain an Army of a sufficient size to sustain the force that we need in the field in order to prevail in this conflict? That was not a problem in Vietnam. You could either increase the ... of course, we barely tapped into the Reserves, as Dr. Sorley can tell you in great detail, during the Vietnam War. So that's the third center of gravity, it seems to me. Does the American soldier believe that this is a war worth risking his or her life for? And secondly, having made that determination, do they think that we've got a chance of winning? So are their hearts in it? And are their minds telling them, "Yes, I'm not dying for a tie here or for a loss. I'm not risking my life and the security of my family for what I believe is a hopeless cause."

These three elements really speak to what Michael Howard ... he wrote this very interesting piece in *Foreign Affairs*, way back in 1979. He talked about the forgotten dimensions of strategy. He said, "There's four dimensions. The technical, the logistical, the operational and the social." And he said, "You Americans ...," he's a Brit, "You Americans in the Vietnam War, you dominated at the technical level. You had all the great gizmos and all the high tech stuff. And logistical. You had more kinds of stuff than anyone could imagine. But at the operational level, your adversary forced you to play his kind of game. If you showed up to play football, he forced you to play soccer. So he had an advantage there. And ultimately,"

Howard argues, “where he won was at the social dimension. You had the means, certainly logistically and technically to continue to persist in that conflict, but you lost the will to continue. You lost at the social dimension of strategy.”

And you can argue that each one of these three centers of gravity centers around the social dimension of strategy. You know, when I was in the Army we used to worry about do we have enough tanks to stop the Soviets? Do we have enough artillery, enough planes, enough air defense? Do we have a big enough force? Nobody worries about that in this kind of conflict. It’s can we secure these centers of gravity, which are socially oriented? So that’s where the struggle is.

Now there’s a problem. There’s a real bad asymmetry operating here. The enemy’s asymmetric advantage is as three is to one. What I mean by that is think of those three centers of gravity. For us to prevail in this war, we have to hold and secure all three. The Iraqi people, the American people, and the American soldier. If we lose any one, we’re in big trouble, we lose the war. The Iraqi people turn on us and say, “We hate you, we want you out. We don’t buy what you’re trying to do.” The American people, which I live in that bubble inside the Beltway in Washington. The hearings last Thursday were big in the sense that the mood in Washington has really darkened since last Thursday. People are really beginning to question things now. You lose the American people, as we saw in Vietnam, you can lose the war. And certainly if the Army breaks, which is another debating pastime inside the Beltway. Is the Army getting close to that red line in terms of recruitment and retention being over stretched, being over stressed? If you lose that, then you lose as well.

So the enemy has a rather dramatic advantage over us, and has a great degree of strategic flexibility, depending on which of the three centers of gravity. A clever enemy, and certainly our enemies seem to be reasonably clever, much more clever than Saddam Hussein. They can switch their level of emphasis. They’ll go after American troops as casualties, protracted war. Go after Iraqi citizens. What will it take to help us, again, influence the center of gravity that we want to undermine to win this war?

There’s also a Catch 22 operative here. Certain things that we do to reinforce our ability to secure one center of gravity can undermine our efforts to secure another. So, for example, recent news about the Striker Brigade being deployed into Baghdad. You could argue that’s helping us to secure Baghdad, secure the confidence of the Iraqi people, but there are two other questions. Okay, securing that one center of gravity, is that over stretching our troops? Is it over stressing them? These are young soldiers who have been told, “You’re going to be in Iraq

for another three months.” Does that undermine our ability to recruit and retain and sustain that force in the field? And of course, the way it’s portrayed in a lot of the media stories is, oh my God, the troop levels are high, we just keep treading water here. What kind of a message does that send to the American people?

So for senior political leaders, for senior commanders, they’ve got to balance that risk. They’ve got to come up with some kind of a strategy that allows them to secure those three centers of gravity, realizing that at times, moving in one direction undermines what you’re trying to do in another area. And that is really tough strategy. That’s not Strategy 101.

Let’s just talk very quickly about the three centers of gravity. Talking about the drum beat a few minutes ago. I have a feeling I’m beating something to death here. This is something I’ve heard a lot the last two days since I’ve been here, but again, this is very much an intelligence war. Nobody’s worried, like I said, about do we have enough tanks or artillery or helicopters. If we know who the enemy is and where the enemy is, the war is over. Question is, how do you find out who they are and where they are? Best source of information is likely the Iraqi people. Likely humans. How do you get that information? Well, the bottom line there is hearts and minds and security. Can you convince them that you’re offering them the best opportunity that they have for themselves and their family for the future? Can you convince them that you’re going to stick it out? Here again, you get that balance. The more we talk about standing them up so we can get the hell out of there, the more they stand there and say, “Well, wait a minute, I need you here.” They may not want to say it publicly, but at the end of the day, hey, you’ve got to stay until you finish the job. So again, the mixed message and the tension that exists between the different centers of gravity in this war.

And finally, security. I may think you’re going to win, and I may want you to win. But if I go down to the police station to report on Ahmed or Abdul or whoever, I don’t want to find a horse’s head in my bed when I get back to my house. Or something a lot worse. So it’s got to be security. And it’s interesting, you see so many different polls and so on, but again and again and again and again, topping the hit parade, number one for 36 months in a row, what the Iraqi people want is security. And as General Warner, who recently retired from Fort Leavenworth said to me, in some of the studies you’ve done here, he has not seen a successful counterinsurgency that did not involve providing security for the population. So that’s the fundamental foundation that has to exist, at least in his mind, based on his studies. And I certainly agree with him. For success in this kind of a war. Again, this is not unique to Iraq. It certainly was the case in Vietnam.

The American public and the American soldier, the other two, the quote from the top there. This was something that was stated by a SAM student, a colleague of mine came here a little over a year ago, and in his presentation to the SAMs group, he had the misfortune to say, "The United States is at war," and he was cut off. And the students said, "America is not at war. The US Army is at war. America's at the mall." And his colleagues pretty much nodded, yeah, that's right. Hard to fight a protracted and difficult and ambiguous kind of aggression when you don't have the home based mobilized. Again, this critical center of gravity. There really is a sense of detachment, I think.

I had a neighbor come up to me and said, "Well, you know who's paying for this war? It's the Japanese and the Chinese. They're buying up our debt, or a lot of it. We're not even paying for this war. We're going to let our children pay for it." Not only that, he couldn't understand if President Bush doesn't want to raise taxes, and there was, in Vietnam a 10 percent surcharge. Those of you who are old like myself remember the famous 10 percent surcharge. There was a debate over that, but Americans actually did pay taxes to help cover that war. Neighbor of mine said, "Why don't we even have a war bond drive? Why aren't the American people even being asked to sacrifice to earn a slightly lower rate of interest or rate of return on their investments, for crying out loud?" So it's very hard to say that this is a serious situation that we find ourselves in, and it requires a lot of sacrifice and it requires a victory at the end, when you're walking around and people tell you, "Well, live life as normally as you can." And you're not being asked to sacrifice.

Go back to World War II, for example. We had the scrap metal drives, and they really were kind of like a lot of the ack-ack that was fired over London, the Battle of Britain. They were just shooting hoping to hit something. Scrap metal really wasn't used for anything. We didn't build any battleships or aircraft carriers out of it, it was to get the American people involved, to make them feel like they had a stake in this war. That they were doing something. And the American people have pretty much been told to either sit on their hands, or as that one Army officer said, "Go to the mall and spend, spend, spend, because that's what drives the economy."

The other aspect is the absence of a draft, also. Which, of course, we had during the Vietnam War. Also gives you a greater level of detachment. At that time, your son ... back in the '60s and early '70s, your son could be drafted. That was a worry. And of course we had a lot more people in Vietnam. We peaked at just short of 550,000. And of course, the United States' substantially smaller population then too. Now the risk is really borne by the institutional Army. Our Generals have to sit there and scratch their heads and say, "How do I convince young American men

and women to join the Army? How do I convince our soldiers to stay?" The burden really has been shifted from the American public to the institution of the US Army. And that's a big burden.

Again, it leads to a certain level of detachment on the part of the American people. Not that they don't care, but there's not that certain level of personal risk and participation, obviously, in the war.

The visceral feeling that this is serious, that there's a war going on, our security is at stake. It kind of reminds us to ... it reminds me anyway, there was an old saying about Italy after World War II, and someone asked our first Ambassador to Italy after Mussolini had been deposed, and we worried about the Communists taking over in Italy. And they said, "Well what's the situation in Italy?" And the answer was, "The situation is critical, but not serious." And it's more of a reflection of the Italian lifestyle, or at least their reputed lifestyle, and I certainly have never seen anything to contradict it, but a sense that things are desperate, yet nobody is taking things seriously. And you have this real disconnect. And, of course, if you've got these three centers of gravity that are so much based on perception, and so much based, I think, to a certain extent, on a willingness to make sacrifice over a protracted period of time, that's worrisome.

So the final question here, if the American public opts out, how long can the Army persist? And I think, again, what we're going to see in the next couple of months, to some extent as we saw in 1968, the election that elected Richard Nixon, who had a secret plan to end the war. There are people now who are arguing that the secret plan to end this war isn't a secret. It's pull the American troops out. And, just as in '68, I think in November this year, people are going to be looking for what kind of a signal the American people are sending in terms of whether the American public is opting out or whether they intend to persist.

Military preparedness. I'm switching now away from the three centers of gravity and talking more about the lead up preparation for this kind of conflict and a bit about the performance.

Doctrine. Really playing catch up, both during the Vietnam War and now. During the early '60s, even though President Kennedy began to push, there was a sense in the Kennedy Administration, very early on, that nuclear weapons made general war between the United States and the Soviet Union something that both would recoil from. That we had blocked conventional aggression in Korea, and so what we were going to see were these wars of national liberation. These insurgency wars that Mao was fostering, that had helped Castro take over in Cuba, that we were

witnessing in Southeast Asia. They had kicked the French out of Indochina. And so there was an effort, during this period, to write doctrine to get the Army ready for these kinds of conflicts. It was a rather slow, fitful process because the Army was still very much focused on the need to prepare for a major war in Europe and to deter the Soviet Union.

Now, of course, we're playing catch up, as well. I was invited a couple of years ago by General Burns, who was the TRADOC Commander at the time, to come and address a group of his Generals that he had gathered for a meeting, and they were just coming up then with a concept draft for counterinsurgency.

Much bigger problem, I think, this time around. I've used with some people the example of can you imagine if, in 1975, somebody told General Motors, "Stop building cars." And then in 2002 said to General Motors, "Start building cars again, only build the 2002 models, not the 1975 models." After the Vietnam War, the Army got out of this kind of business. It got out because it had it's hand on the stove for a decade, to very ill effect, because the American people said, "No more Vietnams." Because the American political leadership said, "No more Vietnams." In the 1980's we had the Powell Doctrine, the Weinberger Doctrine. You know, get in, throw the kitchen sink at them, and get out. In the 1990's we had exit strategies. Governor Bush campaigned in 2000 saying even things like Bosnia and Rwanda and Somalia were bad ideas.

And then 9/11 comes, and all of a sudden, all that changes. And so a business that the Army had gotten out of was all of a sudden a business the Army was supposed to be back in. And it's supposed to be dealing with the 2002 version of insurgency warfare. Tough to do.

Training base. This photograph, again, for those of you who are old like I am, this is the Vietnam Village. They constructed these things and you would have your platoon, your squad, and you'd go through the village and you'd ask the peasant a few questions. You'd look for the booby trap. There was always a hidden document somewhere. It was kind of like a treasure hunt or one of those things. And it really was kind of sophomoric. It really didn't prepare you all that well for going to Southeast Asia.



US Army

Right now what they're doing out at the NTC is light years ahead of that. And the Army's done it remarkably quickly. I mean, as a cadet in the late 1960's, I was still doing the Vietnam Village. What they go through at NTC and JRTC is much advanced. So that's the good news. The bad news is that it's not clear how well you can do high fidelity training in the areas of building up the confidence and the rapport of your Iraqi counterparts. Not sure you can learn that at the NTC. You know, in a society where the social dimensions are going to be critical, where personal relationships count for a lot, if not everything. You can get some technical aspects at NTC, but you can't quite get those sorts of things. And of course, those sorts of things are more important in an insurgency war than they are in a conventional or traditional kind of conflict.

The other thing is, I was in a meeting with Secretary Harvey, and he said, "The US Army has the world's best training infrastructure, and we give our soldiers the best training in the world." And I was in a bad mood that day, and I said, "I think



you're mostly right, Mr. Secretary. On the other hand, I think the Iraqi insurgents probably get the best training in the world right now." They're at the NTC 24 hours a day, seven days a week, and they're going up against the world's best OPFOR. So again, we had an enormous competitive advantage going to the first and the second Gulf Wars, and to Operation ALLIED FORCE and so on, but I think that enormous competitive advantage we had during that period has really been diminished. Just as it was in Southeast Asia. Because you had NVA and Viet Cong who had been at this for years and years and years, and they didn't rotate. They didn't go home. They just stayed there until they burned out or they died or whatever. So that is an area that is somewhat similar to Vietnam, but also different from what we've experienced in recent conflicts.

Professional military education. Again, still playing catch up. I'm on a Marine Board that's looking at Marine professional military education, and I've talked to people like General Warner out here. And again, it's scrambling to catch up. I remember when the Bush Administration came in and they were looking at disestablishing, I think it's the Peace Studies Institute at Carlisle. And there was a big issue there. Should we even have this sort of thing? Well, of course, not only should we have it, but we've got to get our people a lot more involved in understanding these kinds of dynamics. And I'm making the rubble bounce from what a number of people have already said here.

But also, in the early 1960's, there was a lot of catch up going on. What the heck does Kennedy want? He wants this, and it was the big push to increase the training hours. And quite frankly, it's the old Pentagon story of if you want it bad you get it bad. There was a long serving individual here, I think his name was Ivan Behrer. He wrote a fantastic little study where he said, yes, we increased the number of hours devoted to counterinsurgency. What we did was we had the big war in Europe and we put this little appendage of guerillas running around somewhere in Czechoslovakia. So all that training counted as counterinsurgency training. We reported that back to Washington. Everybody was happy. Everybody go home, everybody go to bed.

Force structure. We really built an Army force structure, again, Powell Doctrine, Weinberger Doctrine, exit strategies. We built this force structure for a traditional war, and to essentially run sprints. Short, decisive conflicts. Not for marathons. And yet, you show up for this track meet in Phase IV, and the enemy is forcing you to run a marathon. And of course, the whole modularity initiative and a lot of other things the Army has ongoing on are a reaction to that.

Well, sad to say, it wasn't terribly different in the Vietnam period. A lot of people think the 1st Cavalry Division was this souped up division, and they had designed it for counterinsurgency from the get go. I've done a lot of study on the creation of that division. It was oriented on the European battlefield from start almost to finish. McNamara did not authorize the formation of that division until just before it was sent to Vietnam. And the Generals who did a lot of the thinking and a lot of the field exercises behind it, it was oriented on economy force operations, almost exclusively in Europe, as a screening force. Again, if you want to go into that during the Q&A. But force structure, a lot of modifications had to be made in Vietnam, and as an old Air Defense Officer, there with the system, you know, the Hawk Battery showed up initially at Da Nang, and people kind of looked at it like, "What are you guys doing here?" But that was the initial effort and eventually Air Defense units ended up running convoys and doing things like that. And I understand from talking to some folks like that last night, including General Petraeus, that Air Defense Artillery folks are doing all sorts of strange things they never thought they'd be doing in Iraq right now, too. So again, force structure, big modifications needing to be made.

Finally, something I think that Dr. Mahnken mentioned this morning. Building partner capacity, which is a big issue, at least in the QDR, they talk about this being a way to address the long war, the war on radical Jihadism, or whatever we're calling it this week. We actually had a better position to deal with that during the Vietnam War, in the sense that there were these military assistance advisory groups, these MAGs. We had them in a lot of places around the world. They were training indigenous forces on how to provide for local security and react to insurgent movements.

Advisor duty in Vietnam was coveted between 1961 and 1965. You know, it was the only game in town. If you wanted to get into combat, you needed to be an advisor. Of course, once the main force units start showing up, then you don't want to be an advisor. You want to be the S-3 in that Army battalion, because that's what's going to get you the command of that battalion someday. And of course, we're seeing a similar kind of reaction in Iraq today, except we don't have that MAG structure to build on. We don't have, really, that capability to build partner capacity. And the Army, right now, is being forced to make a very tough choice. We did not structure today's Army with a surplus of officers and NCOs to go become advisors. So when you want to do that for these Iraqi units, you have to start stripping American units. And the question then becomes, well, where are you going to place your bets? What are you going to give priority to? And one of the other problems is, if you ask me as a battalion commander, give up two NCOs and two officers to go be advisors to the Iraqis, who do you think I'm going to give you?

The conduct of the war. There's a fair amount of similarities here. The initial tendency is to do what we do best. In Vietnam it was where are the enemy main units? Find them, fix them, fight them, finish them. That's what we know how to do. General Depuy, who's sort of viewed as the father of search and destroy, looked at what the Marines were doing up in I Corps, which was pacification, more or less, and said that would be a static and glorious use of US Army capabilities. We don't do that sort of thing. We've got too much mobility, we've got too much fire power. We've got to get going here.

Whack-a-mole is one of the phrases that's been used. It's kind of like search and destroy, although it's ... coordinate sweep is what they used to call it. You gather up, instead of a body count, you gather up a lot of suspects and you hope by doing that, somehow you're eliminating some capability in the insurgent force. So there's been an emphasis on that, particularly in the early part of operations. I was down in the J-5 about a year ago. There's a staff element down there that keeps track of a lot of the metrics and a lot of the data that comes in from Iraq. In the middle of the staff table there is this children's game called Whack-A-Mole. You sort of slam the tail of the mole, I guess, and ... I don't know. But they ... I guess during their odd moments, they would play that thing.

Something that's been brought out in these sessions, which is the need to combine or integrate the diplomatic, the security, the reconstruction, the intelligence operations. In both Vietnam and in Iraq, more of a jazz band approach to things. You've got your area, you do what you think is best. Try and coordinate with the others. And it gives you a very uneven kind of operation. So, for example, in Vietnam, the Marines were pursuing what we would probably call pacification or stability operations. General Depuy had a lot of influence on Army divisions. We had about ten over there doing search and destroy operations. General Julian Ewell, who was down in the Mekong Delta with one Army Division, the 9th, really took kind of the notion of how to operate and he really pushed the metric of the body count, which a number of people argue had a very pernicious kind of effect, because if you couldn't discriminate friend from foe, but you were trying to generate a body count, you can imagine some of the terrible things that might happen.

In Iraq, Petraeus really is, I think, from everything I've read and some of my conversations, pursuing more of a traditional counterinsurgency strategy. Tom Ricks, in his book, if you look at that, quite a different approach from Petraeus. And then you have General Chiarelli showing up with non-kinetic warfare, with sort of a different flavor and approach. There are different levels of threat and different environments in all parts of Iraq. That's one of the other interesting things about insurgency warfare. It's not a hurricane, it's not a typhoon. There's a bunch

of micro-climates, and you've got to adapt and adjust to each kind of circumstance. On the other hand, if you're looking at least, as I was for a few years in the Pentagon, to find what is the campaign plan here? Is the dominant approach the Petraeus approach, the Chiarelli approach? You really didn't get a very good answer.

So again, more of a jazz band than a symphony. And this, I thought, was a very telling statement by one senior Army General, a Lieutenant General, in 2004 saying, "We're not going to worry too much about the hearts and minds." Which, of course, if you believe what Krepinevich has to say, doesn't particularly make a lot of sense. But the Army does learn. If you read John Nagle's book, in a sense it's a race against time. Who can adapt more quickly? Who can learn? Who can put themselves in a position to win? Dr. Sorley has written very eloquently and informatively on General Abrams. He adopted the one war strategy, or pushed hard for it after Tet, to begin to integrate the effort to focus on the population as well as on the enemy.

In the 2006 campaign plan, which I've read, there's a significant amount of focus on the oil spot strategy. At least what I call the oil spot strategy. Other people call it the ink spot. And then it's clear, hold and build. But however you want to call it, there seems to be a push in this direction to try and unify some of this diversity and create more of a symphony than a jazz band kind of approach to the war. And of course, the \$64 question is, in a sense in Vietnam we began to adapt and change too late to prevail in that conflict. How are things going to turn out in Iraq?

Also in terms of the prosecution of the war, there are some similarities, and they're a bit disturbing. The first issue here is unity of command. And I think it's been brought out enough, but certainly, again, if you're trying to integrate intelligence, security, reconstruction, the diplomatic effort, as Colonel Newell said, the tribes and the various elements of the Iraqi government, you've got to have unity of command. Well, there is no unity of command. General Casey is not in charge in Baghdad. Ambassador Khalilzad is not in charge in Baghdad. Nobody is in charge in Baghdad. Nobody can integrate and coordinate and direct a coherent overall campaign plan.

That was, to a great extent, the circumstance that we faced in Vietnam. Although there were periods, perhaps the most pronounced was when General Maxwell Taylor retires as Chairman of the Joint Chiefs, President Johnson sends him to Vietnam in 1964 as the Ambassador. And he gives Taylor pretty much a blank check. You do what you want. Of course, he's also a retired four star General who's an Ambassador. And Taylor had ideas about setting up sort of a mini National Security Council and running the war as an integrated effort. Unfortunately, that nev-

er really came to pass. There were efforts later on, and there were good working relationships, too, between people like Ambassador Bunker and General Abrams and General Westmoreland and so on. But you never really had a tightly integrated chain of command. And of course, CORDS was put under MACV. Integrated with MACV to help try and solve that particular problem.

So the other point, I guess, to make is there is no war cabinet back in Washington. There is no centralized day-to-day direction of the war in Washington, which is, to me, remarkable. During the Vietnam War you had the Tuesday luncheons with President Johnson and some of his senior advisors. President Bush does meet with his senior advisors, I guess about every week or so. So there is that. But I think a more interesting model is the one that President Kennedy established, and this is when he decided to send a few thousand advisors to South Vietnam. At the time, he established something called the Senior Interdepartmental Group Counterinsurgency. And to make sure that everyone got the message that they were going to be running an integrated operation, he put Maxwell Taylor in charge. He had just brought him out of retirement and was going to make him Chairman of the Joint Chiefs, and somebody named Bobby Kennedy, who happened to be the President's brother. Taylor was a personal friend of the Kennedy family. Everyone knew that those guys could walk into the West Wing, any time, into the Oval Office. Kennedy had a hands-on interest in what was going on here. You'd be surprised at how the principals sort of gather for those sorts of meetings and have serious discussions when that kind of high level attention is being given to a problem. But we don't have anything comparable to that right now. Again, I think it's a shortcoming, but there it is.

The other question, and I'm glad General Petraeus isn't here because I always get in trouble when I talk to him about this. It's sort of where have all the great Captains gone? And Tom Mahnken, I think, had an interesting way to talk about it. The industrial age way of doing personnel management. Somebody said to me recently, "I think we'd rather lose the war than modify our personnel system." We rotate Generals in and out of Iraq, as though they are interchangeable parts. And yet, when I took military education, you studied Alexander the Great and Julius Caesar and Napoleon and McArthur and Robert E. Lee and General Grant because, in fact, a great General is worth his weight in gold. The force multiplier. I'd rather have Lee with 60,000 than McClellan with 120,000. And yet, when we find good General's, we say, "Well, your year is up, get out."

McArthur started out in 1941 in the Philippines. He came home, not only after that war in helping rebuild Japan, but in fighting the first year of the Korean War. Abrams was over there, what? Four and a half years. Patton ... I'd hate to be the

guy that went to France in '44 to tell Patton, "You've been over here a year, now you've got to go home." George Washington did not have ... in fact he had zero electrical power in his command post, but he was at it from 1775 to 1781. Now there's some cases where Generals burn out. General Hancock, for you Civil War buffs, by 1864, had pretty well burned himself out. Terrific commander in '62 and '63. Just toast by '64. So there are some cases like that.

But if you find ... and I'm glad he's not here for this ... if you find a Petraeus, or you find a Chiarelli, or you find a Barnow, or you find an Olsen, those people are gold. And the only one who's over there right now is Chiarelli. And that is very confusing to me. Again, even in the Vietnam War, I think Westmoreland was there for over four years, Abrams over four years, like I said. That's odd to me.

The cost of the war. How dire are things? A lot of people, especially the press, and maybe it's the 24 hour a day, seven day a week sort of press coverage we get, but it's almost as though, my God, we can't keep this up. We're straining, we're gasping, we're this, we're that. I asked some folks who work with me, "Look at the human and material costs, starting in June '65 and going forward three and a half years, and looking at March of '03 and going forward to where we are now." And that's the US killed in action in Vietnam versus what we've suffered so far in Iraq. The number is a little bit higher because of accidental deaths, but I just have the KIAs down there. And we've spent about \$300 billion, roughly, in both conflicts by this point in current dollars, in '07 dollars. But of course, we have a much bigger economy now. So if you look at how much of our wealth we're actually putting into this war, it's less than a third of what we were spending to deal with the situation in Vietnam.

<b>The Cost of the War Vietnam and Iraq: Three-Plus Years On</b>	
<b>Human</b>	
US Vietnam KIA:	23,051
US Iraq KIA:	2,053
<b>Material</b>	
US in Vietnam:	2.2% of GDP
US in Iraq:	0.7% of GDP

So somehow, this sense that our backs are up against the wall, that we're exhausted and we can't hack it, and it's certainly, at least in terms of these crude measures, it doesn't seem to add up. And of course, this is important because if you're looking to maintain the support of the American people, you want to give them a sense of at least the relative burden that they're bearing in this conflict.

Now I'm going to shift gears a little bit and talk about what I consider to be a critical question at this particular time in the war. And that is, is this a war of choice or is this a war of necessity? And I think there's an interesting twist here with Vietnam. When we went in to Vietnam in 1965, it was felt to be a war of necessity. You had to fight. You couldn't avoid it. Vietnam was going to collapse, Indochina was going to go. If you read Westmoreland's memoirs there were concerns about Indonesia collapsing. They'd had a Communist revolution that was put down in 1964 in Indonesia, the world's largest Muslim state, and so on. So you had to fight here. By the time we withdrew in 1973, the sense was that this was a war of choice. In other words, Nixon had made his opening to China, we had detente with the Soviet Union. Yes, you'd lose Southeast Asia, but you could sort of limit the damage. Not that it wasn't a grievous loss, but that this was not a conflict where your back was up against the wall, arguably.

The opposite, I think, has happened in Iraq. We decided to go to war then. We can debate until the cows come home, okay, should, shouldn't, and so on. But we made a conscious choice in March of '03. We determined the date that we went to war. It was a war of choice in that respect. It was not, I don't think, the central front on the war on terrorism in March of 2003, but it certainly has become, I think, the central front in the war on terror. The war on radical Jihadism. Or radical Islamism. So Vietnam, war of necessity that eventually becomes viewed as a war of choice. Iraq, war of choice that I think now has developed to the point where it's a war of necessity. Because if you look at some of the consequences that we would likely sustain by withdrawing from Iraq, certainly in the state it's in now, I think you're talking about some pretty severe consequences for our security and our economic well being.

Unfortunately, I think the war, as I mentioned before, still being viewed as a war of choice by a lot of the American people. Particularly by the Democratic Party, and some Republicans as well, but it's set a deadline, withdraw, and have everybody out by the end of '07. One of my colleagues, former Army Colonel, said in one of his opinion editorials, "We should just call it a day," as though this is Haiti or Rwanda. You sort of go in, you do the best you can, but you leave after awhile. No particularly great consequences come out of it. The consequences here,

I think, are enormous. But that's a critical question. Is this a war of choice or is this a war of necessity? And who educates the American people about that?

Because if you think, as I do, at this point we're really looking more at a war of necessity, then you've got to make the case because then what you're able to do, if people believe that, is ask for a much higher level of sacrifice. And you also get a much higher level of commitment because people see that the risk and the danger of failing to succeed. Whereas right now, I don't think that applies.

Like the quote from Madeline Albright (Slide 1), sort of "preventive action." Of course, this was in a much more benign situation in the Balkans. We weren't particularly worried about oil going to a bazillion dollars a barrel, and radical Jihadism spreading. I like Orwell's statement too, "If all you care about is getting the war over, well, all you have to do is lose it." If that's the one metric that really focuses your thinking.

**Bottom Line: War of Choice—or Necessity?**

- Vietnam a "war of necessity" that eventually became a "war of choice"  
**Implication: You can withdraw and end the war**
  
- Iraq a "war of choice" that has become a "war of necessity"—that is still being viewed as a "war of choice"  
**Implication: You can retreat, but you are still at war**

*"Common sense tells us that it is sometimes better to deal with instability when it is still at arm's length than to wait until it is at our doorstep."*

**Secretary of State Madeline Albright**

*"The quickest way of ending a war is to lose it."*

**George Orwell**

Courtesy of Dr. Andrew Krepinovich

SLIDE 1



This is the weird slide (Slide 2). Walter Russell Meade, a very interesting statement. He writes this book a couple of years ago. Henry Stinson, at the beginning of our engagement in World War II, the statement at the bottom. And what strikes me is that when Americans think that they are engaged in a war of necessity, they behave very differently. And you can read the ticks going down. When I was talking to General Burns' group of general officers a few years ago, I sort of laid out the different ways of dealing with an insurrection. And one of the ways I mentioned was the Roman way. The phrase, you may have heard, "They created a desert and called it peace." Well, the Roman Army went into North Africa one time to put down a rebellion, and after they did they realized that they couldn't afford to maintain sufficient troops there to pacify the area. So they killed most of the males and they sold the women and children into slavery, and in effect, created a desert, and that enabled them to create peace.

## A War of Necessity? On the Necessity of Being Serious

*"[T]he United States is the most dangerous military power in the history of the world . . . The United States over its history has consistently summoned the will and the means to compel its enemies to yield to its demands."*

Walter Russell Mead

- In wars of necessity—the Civil War and World War II—the United States has deployed devastating force over extended periods and demanded heavy sacrifices (e.g., the draft; rationing) of its citizens
- More German civilians died in the firebombing of Dresden than US battle deaths in all of World War I
- More than twice as many Japanese civilians died in US air strikes in the last six months of World War II than the total US combat deaths in all of America's foreign wars
- More Japanese civilians died in one night of US bombing than US combat deaths in both the Korean and Vietnam wars combined
- The use of atomic weapons on Hiroshima and Nagasaki; "March to the Sea" by General Sherman's army; and Firebombing of German and Japanese cities . . . were all broadly popular in the United States

*"We are determined that before the sun sets on this terrible struggle, our flag will be recognized throughout the world as symbol of freedom on the one hand . . . and of overwhelming power on the other."*

Henry L. Stimson, Secretary of War

Courtesy of Dr. Andrew Krepinovich

SLIDE 2

And so the Generals are saying, “We don’t do that.” And that’s true. On the other hand, I said, “Look at World War II, our last war of necessity, arguably.” Just look at the bullets up there. We did things in World War II. We castigated the Germans for bombing Rotterdam and Warsaw, and then we made them look like candles compared to what we did to Tokyo, and Dresden, and Berlin, and Hamburg and so on. We did that to the nth degree. And the American people were fine with it. We dropped atomic weapons on Hiroshima and Nagasaki. Fine. If that’s what you’ve got to do, do it. We castigated the Germans for submarine warfare because of sinking commerce ships and killing innocent civilians. And we did it to the Japanese, the most ruthless and successful anti-submarine warfare campaign in history.

And I’m saying this, not because I think we should go out and kill a lot of people. That’s not the point. I’m saying this to try and convey the level of seriousness of purpose, and the level of dedication to coming up with a successful outcome to a conflict, when the American people think that it’s a war of necessity as opposed to a war of choice.

And go back to the centers of gravity and the social dimension of it and how the war is depicted and how it’s explained. There’s a phrase in Washington. It’s called the narrative. And the phrase is, “The Administration has lost the narrative.” They’re not telling the story of why we’re in this war, other people are telling the story of why we’re in this war.”

And a big difference in terms of the situation with respect to the indigenous Iraqi people that is fundamentally different from the experience in Vietnam is that in Vietnam, when you went into a hamlet or a village, if there was a radio, that was a big deal. And if that radio could pick up a couple of stations, that was a big deal. And if it could pick up Radio Hanoi, that was a really big deal. In Iraq today, people are bombarded with information. And they’re getting information, a lot of it, from people who are playing the home game. They know the culture, they know the people, they know where their hot buttons are. And we are so far behind in that game, it’s sad. But that’s critical. And that’s why Abu Ghraib, and hopefully it turns out to be wrong, but the damage is already done. Things like Haditha. That’s like Anzio. That’s like Tarawa. That’s like losing a big battle.

The point here is not to advocate indiscriminate violence. It’s the acceptance of a difficult challenge, and the willingness to meet it. I was struck by something President Kennedy said. He was talking about the Cold War, which most Americans felt, over the course of 40 years, was a war of necessity. A cold war of necessity, but one that demanded great sacrifice. And a great sacrifice that they were

willing to make. And you had the greatest generation, which was the World War II generation. You have the Cold War generation. And now I think you have the war of radical Islamism generation, or whatever we ... the long war generation, how's that? But this came out of a discussion I had with one of Khalilzad's people. I said, "You know, this is really tough. This may be too tough." He said, "What do you mean too tough? Suck it up. So it's tough, so what?" And that's what Kennedy is saying. "Okay, it's hard. The hard is what makes it great. That's what will make us a great generation. Generations are measured, not by the challenges that they defer to another generation or another Administration, but the challenges they take on. And they make life better for successor generations." In the case of the United States, hopefully, other parts of the world, as well.

Popular support can be sustained much better in these kinds of circumstances. Think about World War II. It's a great war. Great war of Pearl Harbor, the Philippines, Bataan, the Bataan Death March, Tarawa, Anzio, Omaha Beach, Battle of the Bulge, Okinawa. A lot of disasters along the way, but somehow at the end of the day, you end up in Tokyo and Berlin. One of the big problems we have in this war is people could look at the flack moving in one way or another, you've got to have a way of explaining to the American people how you're making progress in this war, and that's a problem we haven't been able to solve.

Again, I guess my point is the three things we need most of all now is the ability to convince the American people of just how serious this war is. I think the American soldier certainly understands it. That it's being waged competently. And that there's measurable progress. I think if you have those three things, the American people will endure a lot of hardship. But we're running out of time to make that case and do those things.

Can we satisfy these criteria? I think either way, the outcome in Iraq will not resemble the outcome in Vietnam. If we leave and lose, the war isn't over. We left Vietnam and, in a sense, the Communists took over Southeast Asia, and that was pretty much the end of it. If we leave Iraq, it's a retreat. It's not the end of the war. The war goes on. At least with radical Islamism. But the war also, as you're beginning to see, the Iranians, they're in Lebanon, they're in Palestine, they're in southern Iraq, they're in Iran. Who knows? Again, we're looking at, I think, a significant conflict with them as well. If we win, obviously that's a very different outcome from what we saw in the Vietnam War.

I'll leave you with one final comment. It was one by Clemenceau. Clemenceau is the guy who's famous for saying, "War is too important to be left to the generals." He also said this, and you look at our Revolutionary War, you look at our

Civil War, you look at World War II, you look at Korea, depending upon how you view the outcome there, we really had a number of catastrophes along the way to victory. And again, I think getting back to the point of is this a war of choice or is it a war of necessity? How do we communicate that? How do we convince the people that we're waging this war competently? And how do we provide them with indicators so they have some sense that we're making progress? Those are going to be very important over the next six months.

With that, I'll conclude.

## Featured Speaker Question and Answers

(Transcript of Presentation)

### Dr. Andrew Krepinevich

#### Audience Member

Thank you, Dr. Krepinevich, I have enjoyed your books over the years. I just wondered if you could comment a bit on whether we're just dealing with a different American people. Or at least a different American elite, if you want to adopt Christopher Lash's concept that the elite of America have sort of abandoned America and become their own separate entity. It's all well and good for us to all pull together for World War II, but we don't really have people like that. Pat Tillman left professional football, and his teammates went on record in the newspapers to say they thought he was a "damn fool." He wasn't going to get ... there was no draft, and he was giving up a million dollar salary, and what idiot would do something like that to go be a grunt? And certainly if you look at the press, for instance, the *New York Times* twice, reporters have called up terrorist organizations and tipped them off about pending government raids. And then there was a dead Marine, and they got his last letter home and they rewrote it to make it sound like he was discouraged, even though it was a very patriotic and moving letter. And I wonder if ... I completely agree with your concept, but I wonder whether it's even possible any more.

#### Dr. Andrew Krepinevich

Well, that is ... you sort of raised the \$64 question. Is it possible, given current attitudes, to explain to the American people, in a sense, the consequences of what we're engaged in? And I think both parties, quite frankly, have failed to do that. The Administration has failed to clearly state the sacrifices that are going to be necessary to achieve the outcome it seeks, and the loyal opposition, the Democratic party, I think, has understated the consequences of precipitous withdrawal, which a lot of people in the Democratic party are proposing. In terms of the mood of the country, you make a good point about Pat Tillman and so on. There have been writings about ... Sam Huntington, most recently, talks about, in a sense, two schools of thought developing in the United States. One he calls the exceptionalists, and this is sort of the traditional American school that says you've got to get tough. There is a danger here. And there's also the internationalist school that is more of a European bent. That we should work these things through dialogue, and perhaps that's the path, if we can just sit down and work our way through. I think it's, quite frankly, very difficult right now.

I don't think the American people are necessarily different, but I think their perspective of this war is different. That is, it is a war of choice, that we're tired of it, and that we want it to go away. And I think it's going to be difficult, because I think the only person really capable of making that kind of case is the President, whether it's Franklin Roosevelt or Abraham Lincoln or Ronald Reagan or John Kennedy, who was extraordinarily eloquent in talking about the kind of conflict we were engaged in. I don't see that coming from President Bush. I think he's almost a lame duck President right now. He's a President who's party members are sort of distancing themselves from him in the election. And what that means is that maybe we do have a retreat. I don't know.

I was struck by a quote from Churchill right after Munich when it was extraordinarily popular. In a sense, the British and the French abandoned their obligations to Czechoslovakia and allowed Hitler to take the country over and Germany became much stronger as a consequence. And Churchill rose up, after Chamberlain comes back and he's being hailed as an extraordinary hero, and he said, "We've suffered an unmitigated defeat. This is but the first sip of the cup that will be proffered to us time and time again until we take our stand for freedom as in the olden times." And this was in 1938, and of course, by 1940, catastrophe was happening.

And you hate to think that we have to have a catastrophe for the American people to get mobilized, but I think, again, if we pull out precipitously, what you're looking at is not an internal civil war in Iraq, it's a regional war. Because the Iranians are already involved. The Turks have said there is not going to be a Kurdistan. The Saudis will fight, at least with their money, to prevent a Shi'a dominated state in Iraq that will begin to subvert them. So they will work with the Egyptians and the Jordanians and so on. You'll have all this happening on Israel's door step. Not to mention what's going on in Afghanistan and the tensions that exist between Pakistan and India, and the fact that Musharraf, the President of Pakistan, has been marked for death by Al Qaeda. They've already tried two or three times to get him and they haven't. I mean, you are looking at, from the Mediterranean to India, this interconnecting set of conflicts going on. And maybe that's what it takes.

But I'll also tell you that, going back to the first Gulf War, and in some of the recent interactions I've had, the American people seem to have an on/off switch, and there's no dimmer. I remember being in a meeting in the run up to the first Gulf War, where Brent Scowcroft was. And he was talking to a group of civilians, and they wanted to know why we weren't going to use nuclear weapons against Iraq. They were concerned about Saddam's chemical and biological weapons. And it's, "Screw them." Why do we buy all this stuff?

My sister-in-law, who protested against the Vietnam War, you know, she was sent in ... this was during the hostage crisis. "Send the B-52s. I don't care. Turn the place into a parking lot." You get that kind of ... I really do think that it's in the

belly of the beast. I've been in war games recently that involve attacks on the American Homeland, and you get people ... you get a vicious response. Walter Russell Meade is right. It can be terrifying to think what these Americans will do. And they're notoriously unpredictable. Korea is outside our defensive perimeter, we're not going to send American boys to fight a war Asian boys ought to be fighting. You know, we do it time and time again. It's almost like a sucker punch. We tell people ... then we lower the ... we drop a load of bricks on them.

So I don't know. But I do think you're right. It's a very steep hill to climb right now. But I have a feeling we're going to confront that situation sooner or later.

### **Audience Member**

Sir, following on that, in my studies of Vietnam, particularly Karnow and people like that, President Johnson, a master politician, was afraid of what you were saying. He kept talking about he was afraid of the American people's war fever, and they would delay and disrupt everything he really wanted to happen. You're inside the Beltway. Do you think the same thing is happening, for this disengagement you seem to be talking about and the lack of a war cabinet, and things of that nature, sir?

### **Dr. Andrew Krepinevich**

I think Johnson's war fever had a lot to do with his memory ... like you said, he was a very astute politician ... his memory of the Korean War, which was the latest data point that he had to work with. And of course, it pretty much destroyed Truman's presidency. There was also the concern, during that war, about whether you bombed the bridges across the river, whether you bomb Manchuria, and so on. And so ... of course, by that time, you had ... China had nuclear weapons, the Russians had a lot of nuclear weapons, which wasn't the case in 1950. So the potential stakes were a lot higher. He didn't want to rub too hard against the North for the fear the Chinese would intervene. Again, he was sort of looking at a replay of the last war. So there were a lot of things that inhibited him. I think, to a certain extent, we have greater freedom of action right now because there is no nuclear armed Soviet Union and China that's in this game against us.

On the other hand, I think at some point in time, you have to begin to demonstrate some level of competence. You have to ... one of the things that Johnson wasn't able to do was to convince the American people that we were making progress in that war, and that he had a plan. And of course, Nixon said, "I've got the secret plan to win the war." So what is the plan? How are we going to do it? Those sorts of things. I think that's something that President Bush, in a sense, shares with President Johnson, that inability to make the case. Did I answer your question?

**Audience Member**

I just, like I said, President Johnson did have a plan, though. It was the Great Society. Maybe it's the same thing. Is it the Ownership Society, or things of that nature? Is there a fear that overemphasis on the war will cause some problem economically?

**Dr. Andrew Krepinevich**

As I pointed out, this war is taking about a third the level of GDP that the Vietnam War took. The big problem, most economists would tell you, or the big source of concern right now with respect to things like federal deficits is not the cost of the war or even the cost of the Defense budget. It's the cost of the tax cuts. The American Defense budget is somewhere around 4% of GDP. We sustained a budget 50% higher than that, roughly, for the entire length of the Cold War. It's tax cuts and it's entitlements that really take a lot of wind out of the sails and it's the inability to balance the budget, combined with a lot of us Baby Boomers moving into the Social Security ... I mean, the two big concerns, if you're talking about the Defense budget and Defense modernization right now, is there's this bow wave. The program is here, the budget's here. Tough choices have to be made.

But compounding it, as we move into the latter part of this decade, is number one, the enormous federal deficit that gives you very little wiggle room in terms of increasing spending, and the fact the Baby Boomers are going to start retiring, and when they do, they'll be depleting the Social Security Trust Fund. And that's something that the government borrows to help cover the deficit. And when it doesn't have that money to borrow, interest rates are going to go up. Which means it's going to be even more difficult for the government to borrow, because it has to go out on the open market. We're getting a little bit off of Iraq, but I think fundamentally it's the macroeconomic policy. It's not the specific cost of this war, or even the Defense budget, that is going to compromise the Great Society. It's the tax cuts.

**Audience Member**

Sir, Major Story from the Center of Military History. I'd like to ask you to address a different aspect of this which has been brought up this morning regarding anti-Americanism. It would seem to me that all the things you've spoken about with incoherent campaign plans, support of the American people, it applies even more to winning friends and influencing enemies abroad. Of all the difficult policy choices we face, it would seem to me that things as simple as message and engagement and attention are the cheapest ways to win friends and influence enemies. How are we doing in that?



**Dr. Andrew Krepinevich**

Are you talking about the war of ideas?

**Audience Member**

Specifically with the global war on terrorism. If we want to convince the world that it's not about oil.

**Dr. Andrew Krepinevich**

Well, first, in terms of America being liked, we seem to have this real bad need for people to like us. And I was up at the Naval War College and they do an exercise up there with the students at the end of the year, and they're supposed to come up with a Defense Plan, and then they brief it. You have a Murder Board, and I was on the Murder Board. They kept talking about, "Well, we have to do these things. People don't like us, so we have to ..." Think about hearts and minds. People can like you. But what they really care about is can you protect me and are you going to win? We have to live with the people who are going to win. We're going to live with the people who can protect us. If I like you, it's a bonus. Nobody likes to have foreign troops on their soil. You do it because you have to.

You know, the Japanese don't have us there and they're not paying \$6 billion a year because they like us. They ... we're there because they need us. And this notion about ... yes, I would say we're not particularly popular in the world right now, but the book *The Ugly American* was written in the 1950s. And if you think people have liked the world's ... nobody liked Rome. Nobody liked the Pax Britannica. You know, the great thing about the Pax Britannica was ... and this is, I think, about as good as it gets. People said, "Those Brits, those SOBs, they're running the world. But if I can't run the world, I guess I'd rather have them running the world than anybody else." I think that's what you've got to hope for.

Having said that, I do think that there's something to be said for what Joe Nye calls "soft power." Not just economic power, but that the United States is looked to as a responsible power, a power that uses force in a way that's responsible. The United States benefits more from international institutions and the status quo than any other country. So not to undermine that status quo, or that rule set, if you will, that we benefit so much from. One of the big problems, though, that we have, I think, and this gets back to, I think, your question to some extent, we find ourselves, or at least a good portion of Americans find themselves thinking less and less like the rest of the world.

I was over in England a few weeks ago, thank God I'm not there today trying to get on a plane, but if you look at ... first of all, the level of defeatism is much greater. Second, the whole situation between Israel and Lebanon, most people have de-

cided that they're going to blame Israel. So it's ... if you're trying to accommodate yourself to those kinds of feelings, depending upon who you are, you may have a very tough time. So, I think, again, what I said earlier about maintaining the rule set, we benefit by trying to operate within it, but it's ... are we becoming more and more isolated because of bad diplomacy, because of bad choices, or just because we're becoming ... there's a growing difference of opinion?

There are certain countries that are a lot closer to us now than they were five years ago. And they're typically the countries that live in tough neighborhoods that have decided that they're going to fight, or at least they're going to defend themselves. And it's not the South Koreans, and it's not the Taiwanese. But it's certainly the Japanese. It's the Australians. It's the Indians. It's not the French, it's not the Germans, it's not the Italians, it's not the Spanish. Not that we don't have strong common interests with them, but there are countries that have moved a lot closer to us in recent years, as well. So it's not all a bad story.

#### **Audience Member**

Larry Cline, sir. Sort of going back to the first question. Sort of spreading beyond Iraq to the long war or whatever phrase we're using today. Essentially, after 9/11, the response called for by the American people, by the Administration, was to fly and to shop. How does the Administration then turn it around to start demanding sacrifice and start motivating people to take the situation seriously, when in some ways, they seemed to minimize it at the beginning?

#### **Dr. Andrew Krepinevich**

I think, again, as this gentleman here said, it's very difficult. It's difficult because of what you've already said, and your track record. It's difficult because, I think, the President's political standing right now is low. I think his credibility, when he comes before the American people on these kinds of issues, is low. I think he's probably going to be hurt in the November election. So this is ... and the President is probably the person who has to make that kind of case to the American people. I can't imagine anyone else doing it particularly well.

So you'd have to put me down as a bit of a pessimist there. And it's not clear that the next Administration would do it either, which sort of defaults you to a rather nasty outcome. The one thing I will say is I think there's a case to be made. I think there's a case to be made that says this is a war of necessity. That the consequences of losing this war are likely to be profound in terms of the boost to radical Islamism, the boost to Iran, the boost to proliferation, and certainly the boost to oil prices. I think the market's a poor instability and we're looking at instability on a grand scale.

And I think you're also probably looking at a regional conflict, for the reasons I said. One Saudi said, "This isn't going to be a civil war in Iraq, this is going to be a regional war, because we're all going to be involved. We're all going to be indirectly or directly involved in this conflict." Again, when you talk about just beyond that immediate area, Israel, Pakistan, India, all with nuclear weapons. And nobody thought Austria and Hungary's punitive expedition against Serbia would be to the fall of three empires, but it did. And certainly nobody would have done it if they thought that was the outcome, on both sides. So I think we're looking at a very difficult time ahead, don't you?

**Audience Member**

I wonder if I could expand on that question. Do you think it would be healthy, or a good idea for the Armed Forces to play a role in the debate you have told us needs to occur? Or should those of us in uniform be silent participants in the process, regardless of whether or not it's going in the direction you might prefer?

**Dr. Andrew Krepinevich**

Are you talking about retired Generals coming out and ...?

**Audience Member**

Retired generals, active duty generals, whatever.

**Dr. Andrew Krepinevich**

I tend to think that the statements from retired flag officers commenting on a political process is generally something that we ought to try and avoid. For several reasons. One, it kind of begs the question, at least in terms of the latest round, why these people didn't, in a sense, resign in protest when they were on Active Duty and they felt the circumstances were intolerable? There's a case over the last ten years, General Ron Fogelman, Chief of Staff of the Air Force, in the wake of the Khobar Towers bombing, and there was an investigation, and Fogelman thought that one of his officers was unfairly taking the rap. I think it was a Brigadier General. He could not convince Secretary Cohen to change his findings, and Fogelman said, "I resign." He didn't go public. He made his case, and his resignation was an eloquent statement. And that was the end of it. So there's a certain amount of, "Well, why didn't you do this when you were on Active Duty?"

Another aspect of that is if you have retired Generals sort of commenting on the Secretary of Defense's performance, then put yourself in the position of a new Secretary of Defense. Are you going to hire or bring in Generals and Admirals who you think can give you the best advice, or are you going to look for people who

are going to keep their mouths shut and are timid and will be timid later? Or can you really have the kind of candid, brass knuckles, totally honest back and forth between senior commanders and the Secretary of Defense when you're worried about, well, is he going to go to the press? Is she going to go to the press, and say, "He said that and that's why he should resign or he should be fired?"

And finally, if retired Generals and Admirals can ask for the resignation of a Secretary of Defense, why can't they ask for the resignation of a President who, after all, is Commander in Chief? So I just think that ... now in terms of ... I guess two other things. One is certainly you'd like to see a very rich debate in the military literature right now about how do we deal with these problems before us, and I think those problems that have interagency aspects to it or multiple dimensions are certainly fair game for professional inquiry.

**Appendix A  
Conference Program**

**Day 1  
Tuesday, 8 August 2006**

0730 – 0750    **Registration**

0750 – 0800    **Administrative Announcements**

0800 – 0815    **Opening Remarks**

Colonel Timothy R. Reese  
Combat Studies Institute

*Keynote Address*

0815 – 0930    **Keynote Presentation**

Lieutenant General David Petraeus  
Commanding General,  
US Army Combined Arms Center

0930 – 0945    **Break**

*Panel 1*

0945 – 1115    **Historical Overview**

*The Evolution of Military Advising and  
Assistance, 1815-2005*

Dr. Donald Stoker  
US Naval War College

*Army-based Overseas Security Assistance  
Training and Technical Assistance Over the  
Last Twenty Years*

Kenneth Haynes  
US Army Security Assistance Training  
Management Office

*The Role of Advisory Support in the Long War  
Against Terrorist Extremist Groups*

Dr. Thomas G. Mahnken  
The Johns Hopkins University

- 0945 – 1115    **Historical Overview** (*cont'd*)  
Moderator  
Dr. James Willbanks  
US Army Command and General Staff College
- 1115 – 1300    Lunch  
**Lunchtime Presentation**  
*After Saddam: Stabilization or Transformation?*  
Major William Shane Story  
US Army Center of Military History
- Panel 2**
- 1300 – 1430    **Central Asia Perspective**  
*Comparative Great Power Experiences in the Training of Indigenous Forces: Central Asia, India, Haiti*  
Dr. Robert Baumann  
US Army Command and General Staff College  
*Soviet Military Assistance to the Democratic Republic of Afghanistan After the Withdrawal of Soviet Forces, 1989-1991*  
Dr. Jacob Kipp  
Foreign Military Studies Office  
*US-Central Asian Security Cooperation: Miscommunication, Misunderstanding & Missed Opportunities*  
Mr. William Lambert  
US Army Command and General Staff College  
Moderator  
Dr. Mark Gerges  
US Army Command and General Staff College
- 1430 – 1445    **Break**

*Panel 3*

- 1445 – 1615 **Breaking Out of the Box**  
*If You Build It, They Will Come: The Case for  
Establishing Standing Reserve Civil Affairs  
Packages for Nation-Building  
and Security Assistance Operations*  
Captain Kris Alexander  
6th Civil Support Team (WMD), Texas ARNG
- Send in the Amateurs! Recruiting from the  
Private Sector to Accelerate Nation-Building:  
The Experience of the Afghan Reconstruction  
Group*  
Mr. Thomas F. Berner, Esq.  
Afghan Reconstruction Group, Kabul
- Developing Weapons of Mass Construction:  
Expanding the Role of Provincial Reconstruction  
Teams in Sub-National Security Assistance*  
Captain Roberto Bran  
US State Department, Iraqi Reconstruction
- Permanent Implants: Improving Embedded  
Training Team Support to Indigenous Military  
and Security Forces*  
Major Albert Tabarez  
F Team, Operational Detachment Four,  
Joint POW/MIA Accounting Command,  
Camp Smith MCB, Hawaii
- Moderator  
Dr. Joseph Fischer  
US Army Command and General Staff College

1615 – 1630 Administrative Announcements

**Day 2**

**Wednesday, 9 August 2006**

- 0730 – 0750 **Registration**
- 0750 – 0800 **Administrative Announcements**

0800 – 0930 **Key Speaker**

*Security Assistance in the Vietnam War*  
Dr. Lewis Sorley  
Army Historical Foundation

0930 – 0945 **Break**

***Panel 4***

0945 – 1115 **Africa/Malaya Perspectives**

*CORDS and the Vietnam Experience:  
An Interagency Organization for Counterinsurgency  
and Pacification*

Dr. Richard W. Stewart  
US Army Center of Military History

*East to East: PRC Security Assistance to the  
Republic of Tanzania, 1964-76*

Dr. Donovan Chau  
Intelligence and Terrorism Analysis Group

*Building the Malayan Army and Police—Britain's  
Experience During the Malayan Emergency  
1948–1960*

Dr. James Corum  
US Army Command and General Staff College

Moderator  
Dr. Lawrence Yates  
Formerly of the Combat Studies Institute

1115 – 1300 Lunch

**Lunchtime Presentation**

*US–Iraqi Joint Operations*  
Lieutenant Colonel Kevin Farrell  
US Military Academy

***Optional Tour of Historical Fort  
Leavenworth (w/ Bag Lunch)***

Mr. Kelvin Crow  
Combat Studies Institute



*Panel 5*

- 1300 – 1430 **Western Hemisphere Perspective**
- The Alliance Transformed: US–Colombian Security Cooperation, 1950–1960*  
Dr. Bradley Coleman  
US Department of State
- Employment of the Philippine Constabulary (1901–1917) and Haitian Gendarmerie (1916–1934) in Civic Tasks, Such as Anti-Corruption, Against the Background of Counterinsurgency Campaigns*  
Captain Robert Mihara  
Texas A&M University
- Lessons from the US Advisory Efforts in El Salvador*  
Dr. Lawrence Cline  
American Military University
- Moderator  
Dr. Ricardo Herrera  
Combat Studies Institute
- 1430 – 1445 **Break**
- 1445 – 1615 **Key Speaker (Introduction by Dr. Lawrence Yates)**
- Dr. Andrew Krepinevich  
Center for Strategic and Budgetary Assessments

**Day 3**  
**Thursday, 10 August 2006**

- 0730 – 0750 **Registration**
- 0750 – 0800 **Administrative Announcements**

**Panel 6**

- 0800 – 0930 **Middle East Perspective**
- Security Assistance and Counterinsurgency:  
The British Experience in Oman, 1964–1975*  
Mr. Walter C. Ladwig III  
Merton College, Oxford
- Middle Eastern Cultural Impacts on US  
Security Assistance*  
Major Hank Kron  
Defense Institute of Security Assistance  
Management
- Moderator  
Mr. Matt Matthews  
Combat Studies Institute

0930 – 0945 Break

**Panel 7**

- 0945 – 1115 **US Security Assistance to Romania**
- Introductory Comment**  
*A Historical Overview of the Romanian  
Diplomacy and Great Power Security*  
Mr. Joseph M. Isenberg  
Iowa State University
- Post cold War US Security Assistance to  
Romania and the Problem of the ‘Double  
Security Guarantee’—A Romanian Perspective*  
Mr. Adrian Florea  
Iowa State University
- A Transformational Approach to  
Security Assistance: The Case of Romania*  
Major Drew Schumann  
Illinois State University
- Why Is There No Anti-Americanism in Romania  
Today? A Cultural Perspective On Security  
Assistance: the Case of Romania*  
Mr. Silviu Hariton  
Central European University

- 0945 – 1115 **US Security Assistance to Romania** (*cont'd*)  
Moderator  
Mr. Kelvin Crow  
Combat Studies Institute
- 1115 – 1300 Lunch  
**Lunchtime Presentation**  
*Building Iraqi Security Forces From the Bottom  
Up: Task Force 2-2 and the 205th Iraqi Army  
Battalion in Muqdadiyah, Iraq*  
Lieutenant Colonel Peter Newell  
Joint Multinational Training Center, Hohenfels
- 1300 – 1430 **Key Speaker**  
*Expanding Global Military Capacity for  
Humanitarian Intervention*  
Dr. Michael O'Hanlon  
Foreign Policy Studies, Brookings Institution
- 1400 – 1435 **Administrative Announcements**
- 1435 – 1445 **Concluding Remarks**  
Colonel Timothy R. Reese  
Combat Studies Institute



## **Appendix B**

### **About the Presenters**

**Kris Alexander**, Captain, US Army, 6th Civil Support Team (WMD), Texas ARNG is a 1995 graduate of Texas Tech University where he received his commission in the Infantry. His initial assignment was at Fort Campbell, Kentucky with the 101st Airborne Division. Transferring to the Military Intelligence Corps, Captain Alexander departed from active duty and joined the Reserves. His unit was mobilized shortly after the attack on the World Trade Center. He and his unit subsequently supported both Operation Iraqi Freedom, and Operation Enduring Freedom while deployed in 2003. While not mobilized, Mr. Alexander worked in the emergency management/homeland security area, spending most of his time conducting planning for WMD, HAZMAT, critical infrastructure protection, and several other projects. He has also taught several courses related to emergency planning and currently works for a local government.

**Robert Baumann**, PhD, Department of Military History, US Army Command and General Staff College received a B.A. in Russian from Dartmouth College, an M.A. in Russian and East European Studies from Yale University, and a Ph.D. in History from Yale University. Dr. Baumann's extensive publications include his book *Russian-Soviet Unconventional Wars in the Caucasus, Central Asia, and Afghanistan*, as well as coauthoring *Invasion, Intervention, Intervasion: A Concise History of the U.S. Army in Operation Uphold Democracy, My Clan Against the World: A History of US and Coalition Forces in Somalia 1992-1994*, and *Armed Peacekeepers in Bosnia*. A 1999 recipient of a research grant from the United States Institute of Peace in Washington, D.C., Dr. Baumann is also a writer-producer of a documentary film on the U.S. and multinational peacekeeping mission in Bosnia. In addition, he has also written on the history of the Bashkirs and taught briefly as a visiting professor of history at the Bashkir State University in Ufa, Russia in the fall of 1992. Dr. Baumann is also an adjunct faculty member at the University of Kansas and Kansas State University.

**Thomas F. Berner**, Esq., is a partner in the New York office of the Chicago-based law firm Katten Muchin Rosenman LLP. He was the Senior Legal Advisor to the United States Embassy in Kabul from 2004 to 2005 as part of an experimental State Department organization named the Afghanistan Reconstruction Group, designed to expedite and coordinate the reconstruction process. Tom Berner received a B.A. with Honors in Economics from the University of Wisconsin - Madison in 1976 and a JD degree from Columbia University Law School in 1979.

**Roberto Bran**, graduated from the United States Military Academy in December 1999, and was commissioned into the US Army Infantry. He has served with the 11th Armored Cavalry Regiment, as an embedded advisor in the Afghan National Army with Coalition Joint Task Force Phoenix, as interagency plans officer with Combined Forces Command - Afghanistan, and as chief and deputy chief of training for the 2d Infantry Division. Roberto is currently transitioning into the State Department, where he hopes to be selected to join a Provincial Reconstruction Team in Iraq. He is currently pursuing a master's degree from the Maxwell School of Citizenship and Public Affairs at Syracuse University.

**Donovan Chau**, Ph.D., is assigned to the Intelligence and Terrorism Analysis Group at Applied Marine Technology, Inc. (AMTI). He was hired as the area specialist responsible for supervising and conducting research on terrorist threats in and emanating from the continent of Africa. He provides Universal Adversary support for the Department of Homeland Security National Exercise Program. Prior to joining AMTI, Dr. Chau was a Professional Staff Member on the Committee on Homeland Security, U.S. House of Representatives. In that capacity, he conducted policy oversight as well as research and analysis in border and transportation security issues relevant to the Department of Homeland Security. In addition, he worked directly with the Committee Staff Director (Dr. John C. Gannon) to write, coordinate, and edit Chairman Christopher Cox's report, *Freedom Defended: Implementing America's Strategy for Homeland Security*. Dr. Chau earned his Ph.D. in Politics and International Relations from the University of Reading (United Kingdom). Under the supervision of Dr. Colin S. Gray, Dr. Chau wrote and defended his doctoral dissertation entitled "Grand Strategy into Africa: Communist China's Use of Political Warfare, 1955-1976." He also earned an M.S. in Defense and Strategic Studies from Missouri State University as well as a BA in Literature and Government from Claremont McKenna College.

**Lawrence Cline**, Ph.D., earned his Ph.D. in Political Science from the State University of New York at Buffalo, with his dissertation on Islamically-based insurgencies. He earned an MA in International Relations from Boston University and an MA in Military Studies from American Military University. He is a retired US Army Military Intelligence officer, trained as a Middle Eastern Foreign Area Officer. Assignments included service as a UN Military Observer in Egypt and Lebanon; staff officer with 7th Special Forces Group; advisor in El Salvador; senior ground intelligence analyst with Central Command Headquarters during Desert Storm; and Intelligence Production Chief for UNITAF Headquarters in Somalia. His final assignment was as Middle East Intelligence Branch Chief, J-2, Joint Chiefs of Staff. In addition to teaching for the University System, he also teaches counterterrorism to foreign officers and defense officials for the

Center for Civil-Military Relations in Monterey, California. He has written over 20 articles, encyclopedia entries, and book chapters. His latest publication is a monograph for the Strategic Studies Institute, Army War College, titled *Pseudo Operations and Counterinsurgency: Lessons from Other Countries*.

**Bradley L. Coleman**, Ph.D., is a Historian for the Office of the Historian, US Department of State. He holds a B.A. in History from Virginia Military Institute, a M.A. in History from Temple University, and a Ph.D. in History from the University of Georgia. He has published articles in *The Journal of Military History* and was the Editor for a forthcoming volume dealing with Vietnam in the *Foreign Relations of the United States* (U.S. Government Printing Office) series.

**James Corum**, Ph.D., holds a M.A. from Brown, M. Litt. From Oxford, and a Ph.D. from Queen's University, Canada. Dr. Corum is the author of four military history books including *Airpower in Small Wars* (Wray Johnson, 2003). His most recent book, *Quelling the Beast: A Counterinsurgency Strategy for America*, is being published by Zenith Press in 2006. Dr. Corum has authored 40 book chapters and journal articles on a wide variety of military history subjects and strategic studies issues. From 1991 to 2004 Dr. Corum was a professor at the USAF School of Advanced Air and Space Studies, an intensive one-year graduate program for the education of senior strategists, where he created and taught military history courses. In 2005 Dr. Corum was elected to a fellowship at All Souls College, Oxford University and also elected to a Levershulme fellowship in the Department of International Politics at Oxford. While at Oxford Dr. Corum presented several lectures on current and past counterinsurgency strategy and was invited to the British Joint Staff College at Shrivenham as a distinguished visiting lecturer. Dr. Corum is currently an associate professor at the US Army Command and General Staff College, Ft. Leavenworth, Kansas.

**Kelvin D. Crow**, born into a military family (his immediate family has over 100 years' collective military service), received a B.S. from the University of Missouri in 1976. He served as an infantry officer with assignments in the Berlin Brigade, HQ US Army, Europe, and as a Staff Ride Instructor in the US Army Command and General Staff College History Department. He earned an M.A. from Oregon State University in 1988 and an M.M.A.S. from the Command and General Staff College in 1989. Mr. Crow has published several articles in the popular historical press and a book, *Fort Leavenworth: Three Centuries of Service* (Command History Office, Combined Arms Center and Fort Leavenworth, 2004). Since 2002 he has served as the Assistant Command Historian for the Combined Arms Center and Fort Leavenworth.

**Kevin Farrell**, Lieutenant Colonel, US Army, US Military Academy. Commissioned in 1986 from the United States Military Academy, Kevin Farrell served as an armor officer at Fort Hood, Texas; Fort Carson, Colorado; and returned to the academy as an instructor and Assistant Professor of History. Graduating from the US Army's Command and General Staff College in 1998, he deployed with the 1st Infantry Division to Kosovo, and later served as the Aide de Camp to the Commanding General, V Corps, in Heidelberg, Germany and to the Commanding General, Combined Arms Center, Fort Leavenworth, Kansas. He also served as an assistant training officer/advisor to the Afghan National Army in Afghanistan. LTC Farrell has recently returned from a tour in Iraq as commander of the 1-64 Armor Battalion.

**Joseph Fischer**, Ph.D., currently serves as an Associate Professor in the Department of Military History, US Army Command and General Staff College. He received a B.A. in History in 1975 from the Pennsylvania State University and was commissioned as a Second Lieutenant in the Infantry. He returned to civilian life in 1979 earning a B.S. in Secondary Education and an M.A. in History from The Pennsylvania State University. Dr. Fischer reentered the Army serving as a company commander in 3d Armored Division and as an Assistant Professor of Military History at the United States Military Academy at West Point. He later received this Ph.D. in American History at The Pennsylvania State University and served as a command historian at Fort Bragg, North Carolina. Dr. Fischer was also an adjunct professor of history at the Pennsylvania State University, Bloomsburg State University, and Fayetteville State University. Dr. Fischer retired from the US Army Reserves as a lieutenant colonel in 2003.

**Adrian Florea**, received his degrees from the University of Bucharest, and Iowa State University. He was elected Honorary president of ASLS - Students' Association from the Faculty of Foreign Languages and Literatures in 2004. His publications include *International Law and American Attitudes Towards Israel's Settlement Policy*, and *The Politics of Lobbying*. Mr. Florea is currently on the faculty of the Department of English of Iowa State University.

**Mark Gerges**, Ph.D., retired from the US Army in 2004 with the rank of Lieutenant Colonel where he served in armor units and headquarters in Europe, the Middle East and the United States. He received his B.A. in History and Military Studies from Norwich University, Northfield, Vermont, in 1984 and M.A. and Ph.D. from Florida State University, Tallahassee, Florida. His dissertation was on the command and control of the British cavalry under the Duke of Wellington during the Peninsula War of 1808-1814. He has taught history at the United States Military Academy at West Point and the US Army Command and General



Staff College where he is currently an assistant professor in the Department of Military History.

**Silviu Hariton**, is a Ph.D. candidate from the Central European University, having earned his ME at the University of Bucharest in 2005. His areas of research interest are in the modernization and state- and nation-building in South Eastern Europe in the nineteenth and twentieth century; war and society in Europe in the nineteenth and twentieth century; and theories and methods in social and cultural history. Mr. Hariton's numerous publications include "Conscripie militara oi educatie primara in Romania, 1860-1900" in *Revista de Istorie Militara*, nr. 6 (60), and a review of Florin Curta, *The Making of the Slavs: History and Archaeology of the Lower Danube Region c. 500 – 700*. He is a Founding Member of the Association of Romanian Students in Hungary, an Executive Committee Member of the CEU Human Rights Students Initiative HRSI, and member of the Society for Historical Studies, Bucharest, Romania, which is affiliated to International Students of History Association - I.S.H.A.

**Kenneth Haynes**, US Army Security Assistance Training Management Office

**Ricardo Herrera**, PhD, is a member of the Staff Ride Team, Combat Studies Institute, Fort Leavenworth, Kansas. A 1998 Marquette University Ph.D. in U.S. history, he received his B.A. in History from the University of California, Los Angeles. He is the author of several articles and chapters on early-American military history.

**Joseph M. Isenberg**, is an attorney and doctoral candidate in History living in Boone, Iowa. His research, at Iowa State University, focuses on the medieval military history of Eastern Europe, particularly Transylvania and the Romanian Principalities. In 2001-2002, he was a Fulbright Junior Scholar to Romania, where his research project was "Romanian Medieval Military Architecture.

**Jacob W. Kipp**, Ph.D., is Director, Foreign Military Studies Office (FMSO), US Army Training and Doctrine Command, Fort Leavenworth, Kansas, where FMSO hosts the Joint Reserve Intelligence Center. He is a graduate of Shippensburg University and received a Ph.D. in Russian history from Pennsylvania State University in 1970. In 1971, he joined the History Department of Kansas State University. In 1985, he joined the Soviet Army Studies Office (SASO) as a senior analyst. SASO became FMSO in 1991. He has published extensively on Soviet and Russian military history and affairs.

**Andrew Krepinevich, Jr.**, Ph.D., Center for Strategic and Budgetary Assessments is Executive Director of the Center for Strategic and Budgetary Assessments and serves as a member of the Department of Defense's National Defense

Panel. He has written extensively on a variety of security related issues, to include articles published in *The National Interest*, *Issues in Science and Technology*, *Armed Forces Journal*, *Joint Forces Quarterly* and *Strategic Review* among others. Dr. Krepinevich received the 1987 Furniss Award for his book *The Army and Vietnam*, a critical assessment of the service's performance during the war. He gained extensive strategic planning experience in national security and technology policy through his work in the Department of Defense's Office of Net Assessment, and by serving on the personal staff of three secretaries of defense. During this period, Dr. Krepinevich wrote the Defense Department's seminal assessment of the emerging revolution in military affairs. A graduate of West Point, Dr. Krepinevich holds MPA and Ph.D. degrees from Harvard University. In 1993, following an Army career that spanned twenty-one years, Dr. Krepinevich retired from military service to assume the directorship of what is now CSBA and is a member of the Council on Foreign Relations.

**Hank Kron**, Major, US Army is currently the Director of Middle East Studies at the Defense Institute of Security Assistance Management. He graduated from Princeton University with an M.A. in Near East Studies and City University of New York with a B.A. in Political Science. Major Kron has served as an Infantry Commander, Executive Officer, Rifle Platoon Leader, and Anti-Armor Platoon Leader. He was the International Programs Manager for Headquarters, US Central Command, and served as the Deputy Chief, US Liaison Office in the US Embassy, Doha Qatar.

**Walter C. Ladwig III**, Merton College, Oxford

**William Lambert**, is an Assistant Professor in the Department of Joint and Multinational Operations (DJMO), US Army Command and General Staff College. Following initial assignments in the Field Artillery, he served the majority of his Army career as a South Asia Foreign Area Officer (FAO) with positions at Army component and Regional Combatant Command levels as well as at the American Embassy in Pakistan. While acting as the Southwest Indian Ocean Desk Officer at the US Army Pacific Command, he drafted the first-ever US Army International Activities Plan (AIAP) for India. Later, while serving at USCENTCOM as the Chief of the South and Central Asia Branch, Politico-Military Division, J5, he was the principal architect for the integration of the Central Asian region into the CENTCOM AOR. Following retirement from the Army, he served for over three years as an accredited diplomat for the Department of Homeland Security (DHS) at the American Embassy in Uzbekistan as the Export Control and Related Border Security (EXBS) Advisor to Uzbekistan. Over his 27-year government career, he has visited and worked in over 50 countries. He holds undergraduate degrees from the University of Massachusetts and the University of Baluchistan

(Pakistan), and a Masters of International Affairs (MIA) degree from Columbia University. He is a resident graduate of the US Army and Pakistan Command and General Staff Colleges.

**Thomas G. Mahnken**, Ph.D., The Johns Hopkins University, served as acting director of the SAIS Strategic Studies Program from 2003–04 and teaches strategy at the US Naval War College. He has held positions in the government and the private sector, including in the Secretary of Defense's Office of Net Assessment; and was an analyst for the Gulf War Air Power Survey (1991–93). Dr. Mahnken is a member of the Council on Foreign Relations, International Institute for Strategic Studies, Society for Military History, the US Naval Institute, and serves as an officer in the US Naval Reserve. His publications include *The Information Revolution in Military Affairs: Prospects for Asia*, co-editor (2004); *Paradoxes of Strategic Intelligence*, co-author (2003); *The Limits of Transformation*, co-author (2003); *Uncovering Ways of War: U.S. Intelligence and Foreign Military Innovation, 1918–1941* (2002); and numerous articles in *International Security*, *Journal of Strategic Studies*, *Marine Corps Gazette*, and other journals.

**Matt Matthews**, joined the Combat Studies Institute in July 2005 after working for 16 years as a member of the World Class Opposing Force (OPFOR) for the Battle Command Training Program at Fort Leavenworth, Kansas. Mr. Matthews graduated from Kansas State University in 1986 with a B.S. in History. He served as an Infantry enlisted man in the Regular Army from 1977 to 1981; a Cavalry officer in the US Army Reserve from 1983 to 1986; and as an Armor officer in the Kansas Army National Guard from 1986 to 1991. Mr. Matthews has co-authored numerous scholarly articles on the Civil War in the Trans-Mississippi to include *Shot All To Pieces: The Battle of Lone Jack*, *To Play a Bold Game: The Battle of Honey Springs*, and *Better Off in Hell: The Evolution of the Kansas Red Legs*; he is a frequent speaker at Civil War Roundtables; and he recently appeared on the History Channel as a historian for Bill Kurtis' Investigating History. Mr. Matthews was the mayor and city commissioner of Ottawa, Kansas, from 1993 to 1999.

**Robert Mihara**, Captain, US Army, Texas A&M University.

**Peter Newell**, Lieutenant Colonel, US Army, Joint Multinational Training Center, Hohenfels Germany.

**Michael O'Hanlon**, Ph.D., is a Senior Fellow of Foreign Policy Studies at the Brookings Institute, where he specializes in US defense strategy; the use of military force; homeland security; and American foreign policy. He is a visiting lecturer at Princeton University, and a member of the International Institute for Stra-

tegic Studies and the Council on Foreign Relations. The latest of Dr. O'Hanlon's numerous books and publications book is *Defense Strategy for the Post-Saddam Era* (Brookings, 2005), and also he recently completed *The Future of Arms Control* (Brookings, 2005) with co-author Michael Levi. He was an analyst at the Congressional Budget Office from 1989-1994, and previously at the Institute for Defense Analyses. His Ph.D. from Princeton is in public and international affairs. Dr. O'Hanlon served as a Peace Corps volunteer in Congo/Kinshasa (the former Zaire) from 1982-1984.

**David H. Petraeus**, Lieutenant General, US Army, assumed command of the US Army Combined Arms Center and Fort Leavenworth in October 2005 following deployment in Iraq as the first commander of the Multi-National Security Transition Command – Iraq, which he led from June 2004 to September 2005, and the NATO Training Mission – Iraq, which he commanded from October 2004 to September 2005. Previously, he commanded the 101st Airborne Division (Air Assault), leading the “Screaming Eagles” in combat during the first year of Operation Iraqi Freedom. His command of the 101st followed a year deployed on Operation Joint Forge in Bosnia, where he was the Assistant Chief of Staff for Operations of the NATO Stabilization Force and the Deputy Commander of the US Joint Interagency Counter-Terrorism Task Force – Bosnia. He also spent two years at Fort Bragg, North Carolina, serving first as the Assistant Division Commander for Operations of the 82nd Airborne Division and then as the Chief of Staff of XVIII Airborne Corps. He was the General George C. Marshall Award winner as the top graduate of the U.S. Army Command and General Staff College Class of 1983. He subsequently earned MPA and Ph.D. degrees in international relations from Princeton University's Woodrow Wilson School of Public and International Affairs.

**Drew L. Schumann**, Major, US Army Reserve, is currently an Assistant Professor of Military Science at Illinois State University. He graduated from Boston University with an M.A. in International Relations and Iowa State University with a B.A. in History with a Russian Minor. Major Schumann has served as a Transportation, Intelligence and Armor Officer in the US Army. He also has worked as an aviation contractor and is an FAA-certificated aviation maintenance technician.

**Lewis Sorely**, Ph.D., of the US Army Historical Foundation and member of advisory council of Defense Intelligence College is an international consultant on public policy issues, concentrating on national security matters. He is a third-generation US Military Academy graduate who served in Vietnam as executive officer of a tank battalion. Dr. Sorely received his advance degrees at the University of Pennsylvania, (M.A.); Pennsylvania State University, (MPA); Johns Hopkins

University, (Ph.D.), and also attended the Army War College, Naval War College, and Harvard University. Formerly on the faculty at West Point and the US Army War College, he is the author of numerous books and articles on the Vietnam conflict, including *Thunderbolt: General Creighton Abrams and The Army of His Times* and *Vietnam Chronicles: The Abrams Tapes, 1968-1972*. Dr. Sorley is a member of the alumni council of Johns Hopkins School of Advanced International Studies and a member of the International Institute for Strategic Studies. He is also on the board of trustees for the US Military Academy Association of Graduates, Society of the Cincinnati (member of board of directors; chairman of museum and library committee), fellow of the Inter-University Seminar on Armed Forces and Society, and Pi Alpha Alpha.

**Richard Stewart** is currently Chief, Histories Division, Center of Military History, Fort McNair, DC. He received a Ph.D. from Yale University in 1986 and recently received a Masters of Science in National Security Strategy after completing the in-residence course at the National War College. Dr. Stewart was the Command Historian, US Army Special Operations Command, Fort Bragg, North Carolina from 1990-1998, and Historian, US Army Center for Lessons Learned, Fort Leavenworth, Kansas from 1987-1990. A retired colonel in military intelligence, USAR, with 30 years of commissioned service, he has deployed as a combat historian for Operation DESERT STORM (Saudi Arabia and Kuwait), Operations CONTINUE HOPE/SUPPORT HOPE to UNOSOM II (Somalia), MAINTAIN/RESTORE DEMOCRACY (Haiti), JOINT GUARD/JOINT FORCE (Bosnia), DESERT SPRING (Kuwait and Bahrain), and after 9/11 to Afghanistan in support of Operation ENDURING FREEDOM.

**Donald Stoker**, Ph.D., is Professor of Strategy and Policy with the US Naval War College's Monterey Program. He is the author of *Britain, France, and the Naval Arms Trade in the Baltic, 1919-1939: Grand Strategy and Failure* (Frank Cass, 2003), and the co-editor (with Jonathan Grant) of *The Arms Trade in a Global Perspective, 1815-1940* (Praeger, 2003). He is currently editing three books for Routledge Press: *The Evolution of Military Advising, 1815-2005: From Mercenaries to Privatization*; *Conscription in the Napoleonic Age* (with Harold Blanton); and *Strategy in the War for American Independence: A Global Approach* (with Ken Hagan). He has also published articles in magazines such as *Military History Quarterly* and *Naval History*.

**William Shane Story**, Major, US Army, is assigned to the US Army Center of Military History

**Albert Tabarez**, Major, US Army, F Team, Operational Detachment Four, Joint POW/MIA Command, Camp Smith MCB, Hawaii.

**James H. Willbanks**, Ph.D., is Director, Department of Military History, US Army Command and General Staff College. He has been on the faculty since 1992, when he retired from the Army as a Lieutenant Colonel with twenty-three years' service as an infantry officer in various assignments, including being an adviser with an ARVN infantry division in Vietnam and duty in Germany, Japan, and Panama. He is a graduate of the Command and General Staff College and the School of Advanced Military Studies. He holds a B.A. from Texas A&M University and an M.A. and Ph.D. in history from the University of Kansas. He is the author of *Abandoning Vietnam* (University Press of Kansas, 2004), *The Battle of An Loc* (Indiana University Press, 2005), and a forthcoming book on the Tet Offensive to be published this fall by Columbia University Press.

**Lawrence A. Yates**, Ph.D., was a member of the Combat Studies Institute, Fort Leavenworth, Kansas, for 24 years before his retirement in September 2005. He received a B.A. and M.A. in history from the University of Missouri, Kansas City, and a Ph.D. in history from the University of Kansas. He is the author of several articles on US contingency operations since World War II, has written a monograph on the US intervention in the Dominican Republic in 1965, is coeditor and contributor to a book on urban operations, and is author and coauthor of a study of US military operations in the Panama crisis, 1987-1990, and Somalia, 1992-1994, respectively.